

Slewing tower crane

WOLFF 6031.12 clear

Technical information

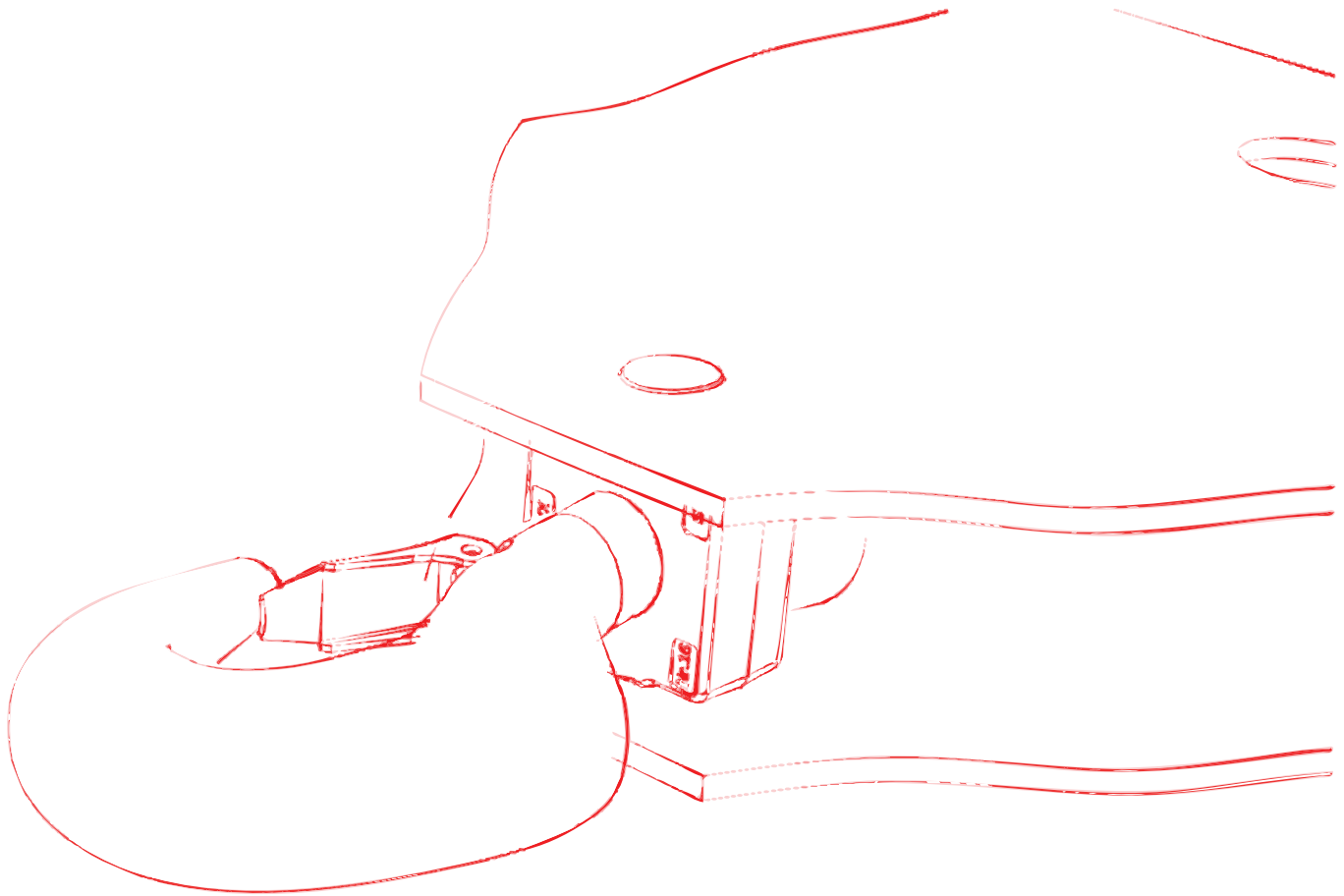

English

English



Published by

WOLFFKRAN GmbH

Austraße 72

74076 Heilbronn

Germany

Phone +49 7131 9815 0

Fax +49 7131 9815 355

www.wolffkran.com

info@wolffkran.de

Copyright

This documentation including all of its subsections is protected by copyright laws.

Any type of use or modification outside of the stringent limits of the copyright laws without permission of WOLFFKRAN GmbH is prohibited and subject to penalties.

This applies particularly for copying, translation, microfilming and storage and processing in electronic systems.

At the time of printing, the information, data, illustrations and notes comprised in this manual were up-to-date.

Subject to change of design, error and typos.

Stand: 03/2017

Table of contents

1	Schedule drawing	5
1.1	Schedule drawing WOLFF 6031.12clear	5
2	Load carrying capacities	6
2.1	Load capacity tables WOLFF 6031.12 clear (8.3 t)	7
2.2	Table of load carrying capacities (kg) in meter intervals, WOLFF 6031.12 clear (8.3 t, 2 fall operation)	8
2.3	Load capacity tables WOLFF 6031.12 clear (12 t)	9
2.4	Table of load carrying capacities (kg) in meter intervals, WOLFF 6031.12 clear (12.0 t, 4 fall operation)	10
3	Tower combinations	11
3.1	Tower combinations on foundation (slewing section with UV 20 / TV 20 - connection)	12
3.2	Tower combinations on cross frame (slewing section with UV 20 - connection)	17
3.3	Tower combinations on cross frame element (slewing section with UV 20 - connection)	22
3.4	Tower combinations on mobile cross frame (slewing section with UV 20 - connection)	24
3.5	Tower combinations on undercarriage (slewing section with UV 20 - connection)	28
4	Foundation loads / central ballast weights / corner loads in compliance with EN 14439 / EN 13001	30
4.1	Foundation loads jib 30 m - 65 m	32
5	Operating speeds	33
6	Package list	35
6.1	Package list 6031.12	35
7	Assembly weights	37
7.1	Counterweight blocks	37
7.1.1	Counterweight block, 2.7 t	38
7.1.2	Counterweight block, 3.7 t	39
7.2	Total weight jib assembly	40
7.3	Assembly weight slewing section	41
7.4	Assembly weight cross frame	42
7.5	Assembly weights traveling cross frame	44
7.6	Assembly weight cross frame elements	46

7.7	Assembly weight undercarriage	47
7.8	Required hook height for mobile cranes	48
8	Assembly diagrams	49
8.1	Jib attachment diagram	49
8.1.1	Slewing Trolley Jib Lifting Diagram 65 m to 55 m (6031.12 clear)	50
8.1.2	Slewing Trolley Jib Lifting Diagram 52.5 m to 42.5 m (6031.12 clear)	51
8.1.3	Slewing Trolley Jib Lifting Diagram 40 m to 30 m (6031.12 clear)	52
8.2	Trolley jib mounting rig	53
8.3	Arrangement of standard railings	54
8.3.1	Standard railings (NG) and accessories	54
8.3.2	Arrangement of standard railings	55
9	Suitable climbing devices	57
9.1	Outer climbing devices	58
9.1.1	Outer climbing device KWH 20.3 / KWH 20.3.1	59
9.1.2	Außenkletterwerk KWH 20.6 / KWH 20.6.1 / KWH 20.6.2	60
9.2	Inner climbing devices	61
9.2.1	Inner climbing device KSH 20 SH	62
10	Arrangement of counterweight blocks	65

1 Schedule drawing

1.1 Schedule drawing WOLFF 6031.12clear

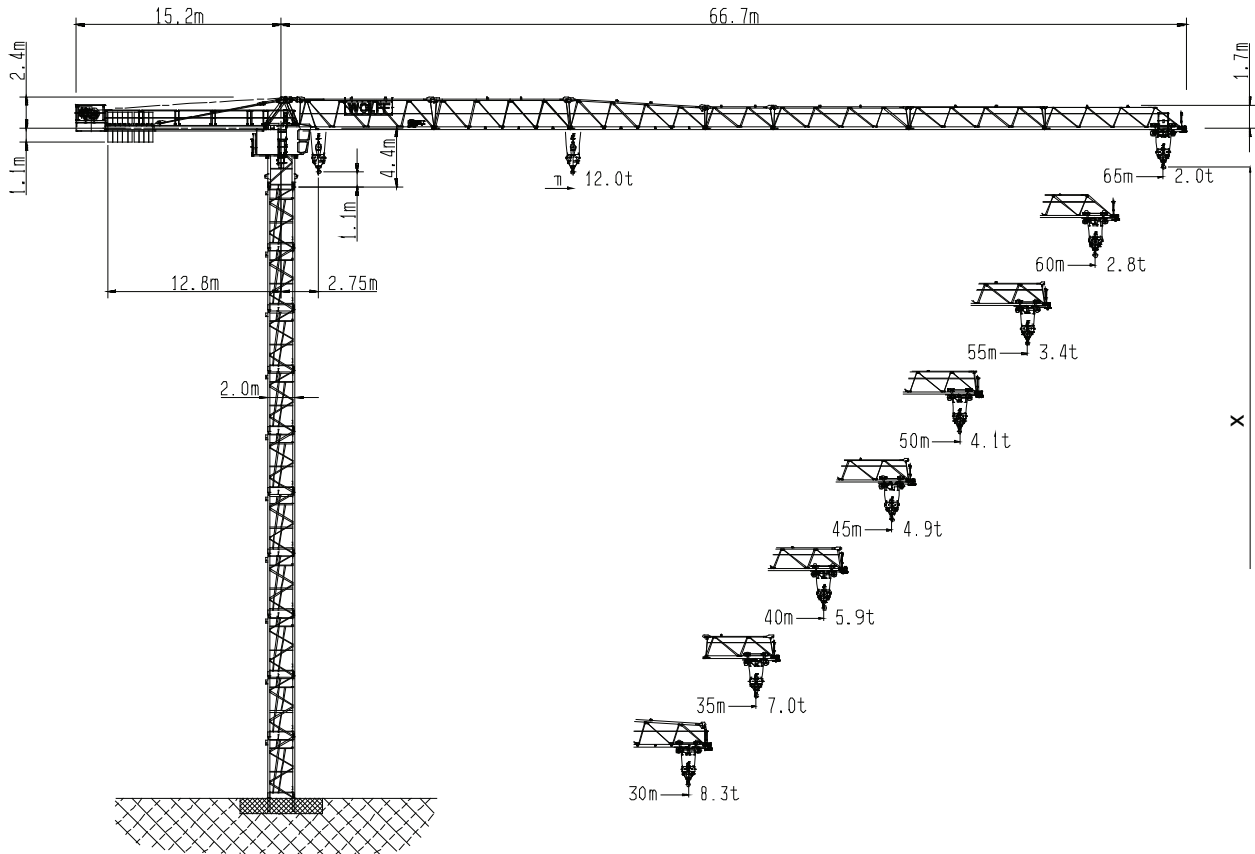

[X]	max. hook height above ground
-----	-------------------------------

Data WOLFF 6031.12clear

Item	Data
Crane type	BGL GROUP C.0.10.0224
Design	Overhead travelling crane with top slewing trolley jib, with climbing feature
Type of setup	Stationary or travelling
Basis of calculation	EN
Payload torque	max. 2580 kNm
Hoist winch	Hw 845FU / Hw 875FU

2 Load carrying capacities

2 Load carrying capacities

	<h3>NOTICE</h3>
<p>WOLFF-Boost</p> <p>With the WOLFF-Boost function, the load is allowed to exceed the load torque range specified for the lifting capacities by up to 10%. This is, however, subject to the restriction that hoisting gear and trolley drive (trolley crane) respectively hoisting gear and derricking gear (luffing crane) must only be moved alternately.</p>	

2.1 Load capacity tables WOLFF 6031.12 clear (8.3 t)

 8.3 t		Operating radius [m]	25	30	32.5	35	37.5	40	42.5	45	47.5	50	52.5	55	57.5	60	62.5	65
			LCC [t]															
JL [m]	65	2.75- 21.4	7.0	5.6	5.1	4.7	4.3	3.9	3.6	3.4	3.1	2.9	2.7	2.6	2.4	2.3	2.1	2.0
	62.5	2.75- 23.3	7.7	6.2	5.6	5.2	4.7	4.4	4.0	3.8	3.5	3.3	3.1	2.9	2.7	2.5	2.4	
	60	2.75- 24.9	8.3	6.7	6.1	5.6	5.1	4.8	4.4	4.1	3.8	3.6	3.4	3.2	3.0	2.8		
	57.5	2.75- 25.7	8.3	7.0	6.3	5.8	5.3	4.9	4.6	4.3	4.0	3.7	3.5	3.3	3.1			
	55	2.75- 26.3	8.3	7.2	6.5	6.0	5.5	5.1	4.7	4.4	4.1	3.9	3.6	3.4				
	52.5	2.75- 26.8	8.3	7.3	6.7	6.1	5.6	5.2	4.8	4.5	4.2	3.9	3.7					
	50	2.75- 27.7	8.3	7.6	6.9	6.3	5.8	5.4	5.0	4.7	4.4	4.1						
	47.5	2.75- 28.3	8.3	7.8	7.1	6.5	6.0	5.6	5.2	4.8	4.5							
	45	2.75- 28.7	8.3	7.9	7.2	6.6	6.1	5.7	5.3	4.9								
	42.5	2.75- 29.4	8.3	8.1	7.4	6.8	6.3	5.8	5.4									
	40	2.75- 29.8	8.3	8.2	7.5	6.9	6.4	5.9										
	37.5	2.75- 29.9	8.3	8.3	7.6	6.9	6.4											
	35	2.75- 30.2	8.3	8.3	7.6	7.0												
	32.5	2.75- 30.1	8.3	8.3	7.6													
	30	2.75- 30.0	8.3	8.3														
JL			Jib length															
LCC			Load carrying capacity															

The load carrying capacity is related to a hook range of 42.0 m. Hook ranges greater than that reduce the maximum load carrying capacity by the weight of the additional hoisting ropes (2 fall operation = 2.5 kg per meter of the hook range).

2 Load carrying capacities

2.2 Table of load carrying capacities (kg) in meter intervals, WOLFF 6031.12 clear (8.3 t, 2 fall operation)

Operating radius [m]	Jib length [m]																
	30	32.5	35	37.5	40	42.5	45	47.5	50	52.5	55	57.5	60	62.5	65		
22	8300	8300	8300	8300	8300	8300	8300	8300	8300	8300	8300	8300	8300	8300	8060		
23	8300	8300	8300	8300	8300	8300	8300	8300	8300	8300	8300	8300	8300	8300	7660		
24	8300	8300	8300	8300	8300	8300	8300	8300	8300	8300	8300	8300	8300	8010	7300		
25	8300	8300	8300	8300	8300	8300	8300	8300	8300	8300	8300	8300	8260	7650	6960		
26	8300	8300	8300	8300	8300	8300	8300	8300	8300	8300	8300	8190	7900	7310	6650		
27	8300	8300	8300	8300	8300	8300	8300	8300	8300	8230	8070	7840	7570	7000	6360		
28	8300	8300	8300	8300	8300	8300	8300	8300	8190	7900	7740	7530	7260	6710	6100		
29	8300	8300	8300	8300	8300	8300	8210	8070	7870	7590	7430	7230	6970	6440	5850		
30	8300	8300	8300	8280	8230	8110	7900	7770	7570	7300	7150	6950	6700	6190	5620		
31		8020	8050	7970	7930	7810	7610	7480	7290	7030	6880	6690	6450	5960	5400		
32		7740	7760	7690	7650	7530	7340	7210	7030	6780	6630	6450	6210	5740	5200		
32.5		7600	7620	7550	7520	7400	7210	7080	6900	6650	6520	6330	6100	5630	5100		
33			7490	7420	7380	7270	7080	6960	6780	6540	6400	6220	5990	5530	5010		
34			7240	7170	7140	7030	6840	6720	6550	6310	6180	6000	5780	5330	4830		
35			7000	6940	6900	6790	6610	6500	6330	6100	5970	5800	5590	5150	4660		
36				6710	6680	6570	6400	6290	6120	5900	5780	5610	5400	4980	4500		
37				6500	6470	6370	6200	6090	5930	5710	5590	5430	5220	4810	4350		
37.5				6400	6370	6270	6100	5990	5830	5620	5500	5340	5140	4730	4270		
38					6270	6170	6010	5900	5740	5530	5410	5260	5060	4660	4200		
39					6080	5980	5820	5720	5570	5360	5250	5090	4900	4510	4070		
40					5900	5810	5650	5550	5400	5200	5090	4940	4750	4370	3940		
41						5640	5490	5390	5240	5050	4940	4790	4610	4240	3810		
42						5480	5330	5230	5090	4900	4790	4650	4470	4110	3700		
42.5						5400	5250	5160	5020	4830	4720	4580	4410	4050	3640		
43							5180	5090	4950	4760	4660	4520	4340	3990	3590		
44							5040	4950	4810	4630	4530	4390	4220	3870	3480		
45							4900	4810	4680	4500	4400	4270	4100	3760	3380		
46								4680	4550	4380	4280	4150	3990	3660	3280		
47								4560	4430	4260	4170	4040	3880	3550	3190		
47.5								4500	4370	4210	4110	3980	3830	3510	3140		
48									4320	4150	4060	3930	3780	3460	3100		
49									4210	4040	3950	3830	3680	3360	3010		
50									4100	3940	3850	3730	3580	3280	2930		
51										3840	3750	3640	3490	3190	2850		
52										3750	3660	3540	3400	3110	2780		
52.5										3700	3610	3500	3360	3070	2740		
53											3570	3460	3320	3030	2700		
54												3480	3370	3230	2950	2630	
55												3400	3290	3150	2880	2560	
56													3210	3080	2810	2500	
57														3140	3010	2740	2440
57.5														3100	2970	2700	2400
58															2930	2670	2370
59															2870	2610	2320
60															2800	2550	2260
61																2490	2200
62																2430	2150
62.5																2400	2120
63																	2100
64																	2050
65																	2000

2.3 Load capacity tables WOLFF 6031.12 clear (12 t)

 12 t		Operating radius [m]	20	25	30	32.5	35	37.5	40	42.5	45	47.5	50	52.5	55	57.5	60	62.5	65	L-CC [t]	
JL [m]	65	2.75-15.3	8.9	6.9	5.5	5.0	4.6	4.2	3.8	3.5	3.3	3.0	2.8	2.6	2.5	2.3	2.2	2.0	1.9		
	62.5	2.75-16.6	9.7	7.6	6.1	5.5	5.1	4.6	4.3	3.9	3.7	3.4	3.2	3.0	2.8	2.6	2.4	2.3			
	60	2.75-17.7	10.5	8.2	6.6	6.0	5.5	5.0	4.7	4.3	4.0	3.7	3.5	3.3	3.1	2.9	2.7				
	57.5	2.75-18.3	10.9	8.5	6.9	6.2	5.7	5.2	4.8	4.5	4.2	3.9	3.6	3.4	3.2	3.0					
	55	2.75-18.8	11.2	8.7	7.1	6.4	5.9	5.4	5.0	4.6	4.3	4.0	3.8	3.5	3.3						
	52.5	2.75-19.1	11.4	8.9	7.2	6.6	6.0	5.5	5.1	4.7	4.4	4.1	3.8	3.6							
	50	2.75-19.7	11.8	9.2	7.5	6.8	6.2	5.7	5.3	4.9	4.6	4.3	4.0								
	47.5	2.75-20.2	12.0	9.4	7.7	7.0	6.4	5.9	5.5	5.1	4.7	4.4									
	45	2.75-20.5	12.0	9.6	7.8	7.1	6.5	6.0	5.6	5.2	4.8										
	42.5	2.75-20.9	12.0	9.9	8.0	7.3	6.7	6.2	5.7	5.3											
	40	2.75-21.2	12.0	10.0	8.1	7.4	6.8	6.3	5.8												
	37.5	2.75-21.3	12.0	10.1	8.2	7.5	6.8	6.3													
	35	2.75-21.5	12.0	10.1	8.3	7.5	6.9														
	32.5	2.75-21.4	12.0	10.1	8.2	7.5															
	30	2.75-21.4	12.0	10.1	8.2																
	JL			Jib length																	
LCC			Load carrying capacity																		



The load carrying capacity is related to a hook range of 42.0 m. Hook ranges greater than that reduce the maximum load carrying capacity by the weight of the additional hoisting ropes (2 fall operation = 2.5 kg per meter of the hook range).

2 Load carrying capacities

2.4 Table of load carrying capacities (kg) in meter intervals, WOLFF 6031.12 clear (12.0 t, 4 fall operation)

Operating radius [m]	Jib length [m]														
	30	32.5	35	37.5	40	42.5	45	47.5	50	52.5	55	57.5	60	62.5	65
15	12000	12000	12000	12000	12000	12000	12000	12000	12000	12000	12000	12000	12000	12000	12000
16	12000	12000	12000	12000	12000	12000	12000	12000	12000	12000	12000	12000	12000	12000	11390
17	12000	12000	12000	12000	12000	12000	12000	12000	12000	12000	12000	12000	12000	11670	10650
18	12000	12000	12000	12000	12000	12000	12000	12000	12000	12000	12000	12000	11800	10950	9990
19	12000	12000	12000	12000	12000	12000	12000	12000	12000	12000	11830	11510	11120	10310	9410
20	12000	12000	12000	12000	12000	12000	12000	12000	11800	11400	11180	10880	10500	9740	8880
21	12000	12000	12000	12000	12000	11950	11660	11470	11180	10800	10590	10300	9940	9220	8400
22	11620	11650	11690	11580	11530	11360	11070	10890	10620	10250	10050	9780	9440	8740	7960
23	11060	11090	11130	11030	10970	10810	10540	10370	10100	9760	9560	9300	8970	8310	7560
24	10550	10580	10610	10520	10470	10310	10050	9880	9630	9300	9110	8860	8550	7910	7200
25	10080	10110	10140	10050	10000	9850	9600	9440	9200	8880	8700	8460	8160	7550	6860
26	9650	9680	9700	9620	9570	9430	9180	9030	8800	8490	8320	8090	7800	7210	6550
27	9240	9270	9300	9220	9170	9030	8800	8650	8430	8130	7970	7740	7470	6900	6260
28	8870	8900	8930	8840	8800	8670	8440	8300	8090	7800	7640	7430	7160	6610	6000
29	8520	8550	8580	8500	8460	8330	8110	7970	7770	7490	7330	7130	6870	6340	5750
30	8200	8230	8250	8180	8130	8010	7800	7670	7470	7200	7050	6850	6600	6090	5520
31		7920	7950	7870	7830	7710	7510	7380	7190	6930	6780	6590	6350	5860	5300
32		7640	7660	7590	7550	7430	7240	7110	6930	6680	6530	6350	6110	5640	5100
32.5		7500	7520	7450	7420	7300	7110	6980	6800	6550	6420	6230	6000	5530	5000
33			7390	7320	7280	7170	6980	6860	6680	6440	6300	6120	5890	5430	4910
34			7140	7070	7040	6930	6740	6620	6450	6210	6080	5900	5680	5230	4730
35			6900	6840	6800	6690	6510	6400	6230	6000	5870	5700	5490	5050	4560
36				6610	6580	6470	6300	6190	6020	5800	5680	5510	5300	4880	4400
37				6400	6370	6270	6100	5990	5830	5610	5490	5330	5120	4710	4250
37.5				6300	6270	6170	6000	5890	5730	5520	5400	5240	5040	4630	4170
38					6170	6070	5910	5800	5640	5430	5310	5160	4960	4560	4100
39					5980	5880	5720	5620	5470	5260	5150	4990	4800	4410	3970
40					5800	5710	5550	5450	5300	5100	4990	4840	4650	4270	3840
41						5540	5390	5290	5140	4950	4840	4690	4510	4140	3710
42						5380	5230	5130	4990	4800	4690	4550	4370	4010	3600
42.5						5300	5150	5060	4920	4730	4620	4480	4310	3950	3540
43							5080	4990	4850	4660	4560	4420	4240	3890	3490
44							4940	4850	4710	4530	4430	4290	4120	3770	3380
45							4800	4710	4580	4400	4300	4170	4000	3660	3280
46								4580	4450	4280	4180	4050	3890	3560	3180
47								4460	4330	4160	4070	3940	3780	3450	3090
47.5								4400	4270	4110	4010	3880	3730	3410	3040
48									4220	4050	3960	3830	3680	3360	3000
49									4110	3940	3850	3730	3580	3260	2910
50									4000	3840	3750	3630	3480	3180	2830
51										3740	3650	3540	3390	3090	2750
52										3650	3560	3440	3300	3010	2680
52.5										3600	3510	3400	3260	2970	2640
53											3470	3360	3220	2930	2600
54											3380	3270	3130	2850	2530
55											3300	3190	3050	2780	2460
56												3110	2980	2710	2400
57												3040	2910	2640	2340
57.5												3000	2870	2600	2300
58													2830	2570	2270
59													2770	2510	2220
60													2700	2450	2160
61														2390	2100
62														2330	2050
62.5														2300	2020
63															2000
64															1950
65															1900

3 Tower combinations

	<p style="text-align: center;">! DANGER</p> <p>Usage of incorrect tower combinations. The slewing tower crane may overturn.</p> <ol style="list-style-type: none">1) Use the specified tower combinations.2) If you need another tower combination that is not specified here, please contact WOLFFKRAN to get an approved alternative setup in writing.
	<p style="text-align: center;">NOTICE</p> <p>All tower combinations apply to free standing slewing tower cranes without climbing gear.</p>
	<p style="text-align: center;">NOTICE</p> <p>For tower combination with tower element TV 25 and UV 25 please contact WOLFFKRAN.</p>

3 Tower combinations

3.1 Tower combinations on foundation (slewing section with UV 20 / TV 20 - connection)

Jib length	30 m – 65 m				
Item					
1	4.5 m	UV 20.4	UV 20.4	TV 20.4	
2	9.0 m	UV 20.4	UV 20.4	TV 20.4	
3	13.5 m	UV 20.4	UV 20.4	TV 20.4	
4	18.0 m	UV 20.4	UV 20.4	TV 20.4	
5	22.5 m	UV 20.4	UV 20.4	TV 20.4	
6	27.0 m	UV 20.4	UV 20.4	TV 20.4	
7	31.5 m	UV 20.4	UV 20.4	TV 20.4	
8	36.0 m	UV 20.4	UV 20.4	TV 20.4	
9	40.5 m	UV 20.4	UV 20.4	TV 20.4	
10	45.0 m	UV 20.4	UV 20.4	TV 20.4	
11	49.5 m	UV 20.4	TVA 20.4	TV 20.4	
12	54.0 m		TV 20.4	TV 20.4	
13	58.5 m		TV 20.4	TV 20.4	
14	63.0 m		TV 20.4	TV 20.4	
15	67.5 m		TV 20.4	TV 20.4	
Foundation anchors		FUA 120 type C-120	FUA 140 type D-140	FUA 140 type D-140	
Tower height [m]		49.5	67.5	67.5	
Hook height double reeving [m]		51.0	69.0	69.0	
Hook height quadruple reeving [m]		50.6	68.6	68.6	
Wind category		C25			

Jib length	30 m – 65 m			
Item				
1	4.5 m	UV 20.4		
2	9.0 m	UV 20.4		
3	13.5 m	UV 20.4		
4	18.0 m	UV 20.4		
5	22.5 m	UV 20.4		
6	27.0 m	UV 20.4		
7	31.5 m	UV 20.4		
8	36.0 m	UV 20.4		
9	40.5 m	UV 20.4		
10	45.0 m	UV 20.4		
11	49.5 m	TVA 20.4		
12	54.0 m	TV 20.4		
13	58.5 m	TV 20.4		
14	63.0 m	TV 20.4		
15	64.0 m	VR 2023		
16	68.5 m	TV 23		
17	73.0 m	TV 23		
Foundation anchors		FUA 140 type D-140		
Tower height [m]		73.0		
Hook height double reeving [m]		74.5		
Hook height quadruple reeving [m]		74.1		
Wind category	C25			

3 Tower combinations

Jib length	30 m – 65 m			
Item				
1	4.5 m	UV 20.4		
2	9.0 m	UV 20.4		
3	13.5 m	UV 20.4		
4	18.0 m	UV 20.4		
5	22.5 m	UV 20.4		
6	27.0 m	UV 20.4		
7	31.5 m	UV 20.4		
8	36.0 m	UV 20.4		
9	40.5 m	UV 20.4		
10	45.0 m	TVA 20.4		
11	49.5 m	TV 20.4		
12	54.0 m	TV 20.4		
13	58.5 m	TV 20.4		
14	63.0 m	TV 20.4		
15	64.0 m	VR 2023		
16	68.5 m	TV 23		
17	73.0 m	HTA 23		
18	77.5 m	HT 23		
19	82.0 m	HT 23		
20	86.5 m	HT 23		
Foundation anchors		FUA 160 G		
Tower height [m]		86.5		
Hook height double reeving [m]		88.0		
Hook height quadruple reeving [m]		87.6		
Wind category			C25	

Jib length	30 m – 65 m			
Item				
1	4.5 m	UV 20.4		
2	9.0 m	UV 20.4		
3	13.5 m	UV 20.4		
4	18.0 m	UV 20.4		
5	22.5 m	UV 20.4		
6	27.0 m	UV 20.4		
7	31.5 m	UV 20.4		
8	36.0 m	UV 20.4		
9	40.5 m	UV 20.4		
10	45.0 m	TVA 20.4		
11	49.5 m	TV 20.4		
12	54.0 m	TV 20.4		
13	58.5 m	TV 20.4		
14	59.5 m	VR 2023		
15	64.0 m	TV 23		
16	68.5 m	HTA 23		
17	73.0 m	HT 23		
18	77.5 m	HT 23		
19	82.0 m	HT 23		
20	93.3 m	BT 23		
Foundation anchors		FUA 210 G		
Tower height [m]		93.3		
Hook height double reeving [m]		94.8		
Hook height quadruple reeving [m]		94.4		
Wind category		C25		

3 Tower combinations

Jib length	30 m – 65 m			
Item				
1	4.5 m	UV 20.4		
2	9.0 m	UV 20.4		
3	13.5 m	UV 20.4		
4	18.0 m	UV 20.4		
5	22.5 m	UV 20.4		
6	27.0 m	UV 20.4		
7	31.5 m	UV 20.4		
8	36.0 m	UV 20.4		
9	40.5 m	UV 20.4		
10	45.0 m	TVA 20.4		
11	49.5 m	TV 20.4		
12	54.0 m	TV 20.4		
13	58.5 m	TV 20.4		
14	59.5 m	VR 2023		
15	64.0 m	TV 23		
16	68.5 m	HTA 23		
17	73.0 m	HT 23		
18	77.5 m	HT 23		
19	78.7 m	VR 23/25-29		
20	83.2 m	UV 29		
21	87.7 m	UV 29		
22	92.2 m	UV 29		
23	102.2 m	BT 29		
Foundation anchors		FUA BT 29		
Tower height [m]		102.2		
Hook height double reeving [m]		103.7		
Hook height quadruple reeving [m]		103.3		
Wind category	C25			

3.2 Tower combinations on cross frame (slewing section with UV 20 - connection)

Jib length	30 m – 65 m				
Elements					
1	4.5 m	UV 20.4	UV 20.4	UV 20.4	UV 20.4
2	9.0 m	UV 20.4	UV 20.4	UV 20.4	UV 20.4
3	13.5 m	UV 20.4	UV 20.4	UV 20.4	UV 20.4
4	18.0 m	UV 20.4	UV 20.4	UV 20.4	UV 20.4
5	22.5 m	UV 20.4	UV 20.4	UV 20.4	UV 20.4
6	27.0 m	UV 20.4	UV 20.4	UV 20.4	UV 20.4
7	31.5 m	UV 20.4	UV 20.4	UV 20.4	UV 20.4
8	36.0 m		UV 20.4	UV 20.4	UV 20.4
9	40.5 m		UV 20.4	UV 20.4	UV 20.4
10	45.0 m		UV 20.4	UV 20.4	UV 20.4
11	49.5 m		UV 20.4	TVA 20.4	TVA 20.4
12	54.0 m			TV 20.4	TV 20.4
13	58.5 m			TV 20.4	TV 20.4
14	63.0 m				TV 20.4
15	67.5 m				TV 20.4
Substructure		KRV 7-32/46	KR 10-46 KR 10-46/60	KR 10-46 KR 10-46/60	KRV 10-60
Corner distance [m x m]		4.6 x 4.6	4.6 x 4.6 6.0 x 6.0	4.6 x 4.6 6.0 x 6.0	5.0 x 5.0 6.0 x 6.0
Substructure height [m]		0.9	1.2	1.2	1.2
Tower height [m]		32.4	50.7	59.7	68.7
Hook height double reeving [m]		33.9	52.2	61.2	70.2
Hook height 4 fall operation [m]		33.5	51.8	60.8	69.8
Wind category		C25			

3 Tower combinations

Jib length	30 m – 65 m			
Elements				
1	4.5 m	UV 20.4		
2	9.0 m	UV 20.4		
3	13.5 m	UV 20.4		
4	18.0 m	UV 20.4		
5	22.5 m	UV 20.4		
6	27.0 m	UV 20.4		
7	31.5 m	UV 20.4		
8	36.0 m	UV 20.4		
9	40.5 m	UV 20.4		
10	45.0 m	UV 20.4		
11	49.5 m	TVA 20.4		
12	54.0 m	TV 20.4		
13	58.5 m	TV 20.4		
14	63.0 m	TV 20.4		
15	64.0 m	VR 2023		
16	68.5 m	TV 23		
17	73.0 m	TV 23		
Substructure		KRV 10-60		
Corner distance [m x m]		6.0 x 6.0		
Substructure height [m]		1.2		
Tower height [m]		74.2		
Hook height double reeving [m]		75.7		
Hook height 4 fall operation [m]		75.3		
Wind category	C25			

Jib length	30 m – 65 m			
Elements				
1	4.5 m	UV 20.4		
2	9.0 m	UV 20.4		
3	13.5 m	UV 20.4		
4	18.0 m	UV 20.4		
5	22.5 m	UV 20.4		
6	27.0 m	UV 20.4		
7	31.5 m	UV 20.4		
8	36.0 m	UV 20.4		
9	40.5 m	UV 20.4		
10	45.0 m	UV 20.4		
11	49.5 m	TVA 20.4		
12	54.0 m	TV 20.4		
13	58.5 m	TV 20.4		
14	63.0 m	TV 20.4		
15	67.5 m	TV 20.4		
Substructure		KR 12-60 KR 12-60/80		
Corner distance [m x m]		6.0 x 6.0 8.0 x 8.0		
Substructure height [m]		1.4		
Tower height [m]		68.9		
Hook height double reeving [m]		70.4		
Hook height 4 fall operation [m]		70.0		
Wind category	C25			

3 Tower combinations

Jib length	30 m – 65 m			
Elements				
1	4.5 m	UV 20.4	UV 20.4	
2	9.0 m	UV 20.4	UV 20.4	
3	13.5 m	UV 20.4	UV 20.4	
4	18.0 m	UV 20.4	UV 20.4	
5	22.5 m	UV 20.4	UV 20.4	
6	27.0 m	UV 20.4	UV 20.4	
7	31.5 m	UV 20.4	UV 20.4	
8	36.0 m	UV 20.4	UV 20.4	
9	40.5 m	UV 20.4	UV 20.4	
10	45.0 m	UV 20.4	TVA 20.4	
11	49.5 m	TVA 20.4	TV 20.4	
12	54.0 m	TV 20.4	TV 20.4	
13	58.5 m	TV 20.4	TV 20.4	
14	63.0 m	TV 20.4	TV 20.4	
15	64.0 m	VR 2023	VR 2023	
16	68.5 m	TV 23	TV 23	
17	73.0 m	TV 23	HTA 23	
18	77.5 m	HTA 23	HT 23	
19	82.0 m	HT 23	HT 23	
20	86.5 m		HT 23	
Substructure		KR 12-60 KR 12-60/80	KR 16-80 KR 16-80/100	
Corner distance [m x m]		6.0 x 6.0 8.0 x 8.0	8.0 x 8.0 10.0 x 10.0	
Substructure height [m]		1.4	1.8	
Tower height [m]		83.4	88.3	
Hook height double reeving [m]		84.9	89.8	
Hook height 4 fall operation [m]		84.5	89.4	
Wind category		C25		

Jib length	30 m – 65 m			
Elements				
1	4.5 m	UV 20.4		
2	9.0 m	UV 20.4		
3	13.5 m	UV 20.4		
4	18.0 m	UV 20.4		
5	22.5 m	UV 20.4		
6	27.0 m	UV 20.4		
7	31.5 m	UV 20.4		
8	36.0 m	UV 20.4		
9	40.5 m	UV 20.4		
10	45.0 m	TVA 20.4		
11	49.5 m	TV 20.4		
12	54.0 m	TV 20.4		
13	58.5 m	TV 20.4		
14	59.5 m	VR 2023		
15	64.0 m	TV 23		
16	68.5 m	HTA 23		
17	73.0 m	HT 23		
18	77.5 m	HT 23		
19	82.0 m	HT 23		
20	83.2 m	VR 23/25-29		
21	87.7 m	UV 29		
22	97.7 m	BT 29		
Substructure		KR 16-80 KR 16-80/100		
Corner distance [m x m]		8.0 x 8.0 10.0 x 10.0		
Substructure height [m]		1.8		
Tower height [m]		99.5		
Hook height double reeving [m]		101.0		
Hook height 4 fall operation [m]		100.6		
Wind category		C25		

3 Tower combinations

3.3 Tower combinations on cross frame element (slewing section with UV 20 - connection)

Jib length	30 m – 65 m				
Elements					
1	4.5 m	UV 20.4	UV 20.4	UV 20.4	UV 20.4
2	9.0 m	UV 20.4	UV 20.4	UV 20.4	UV 20.4
3	13.5 m	UV 20.4	UV 20.4	UV 20.4	UV 20.4
4	18.0 m	UV 20.4	UV 20.4	UV 20.4	UV 20.4
5	22.5 m	UV 20.4	UV 20.4	UV 20.4	UV 20.4
6	27.0 m	UV 20.4	UV 20.4	UV 20.4	UV 20.4
7	31.5 m	UV 20.4	UV 20.4	UV 20.4	UV 20.4
8	36.0 m		UV 20.4	UV 20.4	UV 20.4
9	40.5 m			UV 20.4	UV 20.4
10	45.0 m			UV 20.4	UV 20.4
11	49.5 m			TVA 20.4	TVA 20.4
12	54.0 m				TV 20.4
Substructure		KRE 260.1	KRE 260.1	KRE 260.2	KRE 260.2
Corner distance [m x m]		5.0 x 6.79	6.0 x 6.0	5.0 x 6.79	6.0 x 6.0
Substructure height [m]		4.0	4.0	4.0	4.0
Tower height [m]		35.5	40.0	53.5	58.0
Hook height double reeving [m]		37.0	41.5	55.0	59.5
Hook height 4 fall operation [m]		36.6	41.1	54.6	59.1
Wind category		C25			

Jib length	30 m – 65 m			
Elements				
1	4.5 m	UV 20.4		
2	9.0 m	UV 20.4		
3	13.5 m	UV 20.4		
4	18.0 m	UV 20.4		
5	22.5 m	UV 20.4		
6	27.0 m	UV 20.4		
7	31.5 m	UV 20.4		
8	36.0 m	UV 20.4		
9	40.5 m	UV 20.4		
10	45.0 m	UV 20.4		
11	49.5 m	TVA 20.4		
12	54.0 m	TV 20.4		
13	58.5 m	TV 20.4		
14	63.0 m	TVÜ 20.4		
15	67.5 m	UVA 25		
Substructure		KRE 480		
Corner distance [m x m]		8.0 x 8.0		
Substructure height [m]		4.0		
Tower height [m]		71.5		
Hook height double reeving [m]		73.0		
Hook height 4 fall operation [m]		72.6		
Wind category	C25			

3 Tower combinations

3.4 Tower combinations on mobile cross frame (slewing section with UV 20 - connection)

Jib length	30 m – 65 m				
Elements					
1	4.5 m	UV 20.4	UV 20.4	UV 20.4	UV 20.4
2	9.0 m	UV 20.4	UV 20.4	UV 20.4	UV 20.4
3	13.5 m	UV 20.4	UV 20.4	UV 20.4	UV 20.4
4	18.0 m	UV 20.4	UV 20.4	UV 20.4	UV 20.4
5	22.5 m	UV 20.4	UV 20.4	UV 20.4	UV 20.4
6	27.0 m	UV 20.4	UV 20.4	UV 20.4	UV 20.4
7	31.5 m	UV 20.4	UV 20.4	UV 20.4	UV 20.4
8	36.0 m	UV 20.4	UV 20.4	UV 20.4	UV 20.4
9	40.5 m	UV 20.4	UV 20.4	UV 20.4	UV 20.4
10	45.0 m	UV 20.4	UV 20.4	TVA 20.4	TVA 20.4
11	49.5 m		TVA 20.4	TV 20.4	TV 20.4
12	54.0 m		TV 20.4	TV 20.4	TV 20.4
13	58.5 m			TV 20.4	TV 20.4
14	63.0 m			TV 20.4	TV 20.4
15	67.5 m			TV 20.4	TV 20.4
Substructure		KRF 10-46/60	KRF 10-46/60	KRF4 12-60/80	KRF6 12-60/80
Corner distance [m x m]		6.0 x 6.0	6.0 x 6.0	8.0 x 8.0	8.0 x 8.0
Substructure height [m]		2.0	2.0	2.5	2.9
Tower height [m]		47.0	56.0	70.0	70.4
Hook height double reeving [m]		48.5	57.5	71.5	71.9
Hook height 4 fall operation [m]		48.1	57.1	71.1	71.5
Wind category		C25			

Jib length	30 m – 65 m			
Elements				
1	4.5 m	UV 20.4		
2	9.0 m	UV 20.4		
3	13.5 m	UV 20.4		
4	18.0 m	UV 20.4		
5	22.5 m	UV 20.4		
6	27.0 m	UV 20.4		
7	31.5 m	UV 20.4		
8	36.0 m	UV 20.4		
9	40.5 m	TVA 20.4		
10	45.0 m	TV 20.4		
11	49.5 m	TV 20.4		
12	54.0 m	TV 20.4		
13	58.5 m	TV 20.4		
14	63.0 m	TV 20.4		
15	67.5 m	TV 20.4		
16	68.5 m	VR 2023		
17	73.0 m	TV 23		
18	77.5 m	HTA 23		
Substructure		KRF6 12-60/80		
Corner distance [m x m]		8.0 x 8.0		
Substructure height [m]		2.9		
Tower height [m]		80.4		
Hook height double reeving [m]		81.9		
Hook height 4 fall operation [m]		81.5		
Wind category	C25			

3 Tower combinations

Jib length	30 m – 65 m			
Elements				
1	4.5 m	UV 20.4		
2	9.0 m	UV 20.4		
3	13.5 m	UV 20.4		
4	18.0 m	UV 20.4		
5	22.5 m	UV 20.4		
6	27.0 m	UV 20.4		
7	31.5 m	UV 20.4		
8	36.0 m	UV 20.4		
9	40.5 m	TVA 20.4		
10	45.0 m	TV 20.4		
11	49.5 m	TV 20.4		
12	54.0 m	TV 20.4		
13	58.5 m	TV 20.4		
14	63.0 m	TV 20.4		
15	64.0 m	VR 2023		
16	68.5 m	TV 23		
17	73.0 m	HTA 23		
18	77.5 m	HT 23		
19	82.0 m	HT 23		
20	86.5 m	HT 23		
Substructure		KRF 16-80/100		
Corner distance [m x m]		10.0 x 10.0		
Substructure height [m]		3.3		
Tower height [m]		89.8		
Hook height double reeving [m]		91.3		
Hook height 4 fall operation [m]		90.9		
Wind category	C25			

Jib length	30 m – 65 m			
Elements				
1	4.5 m	UV 20.4		
2	9.0 m	UV 20.4		
3	13.5 m	UV 20.4		
4	18.0 m	UV 20.4		
5	22.5 m	UV 20.4		
6	27.0 m	UV 20.4		
7	31.5 m	UV 20.4		
8	36.0 m	UV 20.4		
9	40.5 m	TVA 20.4		
10	45.0 m	TV 20.4		
11	49.5 m	TV 20.4		
12	54.0 m	TV 20.4		
13	58.5 m	TV 20.4		
14	59.5 m	VR 2023		
15	64.0 m	TV 23		
16	68.5 m	TV 23		
17	73.0 m	HTA 23		
18	77.5 m	HT 23		
19	82.0 m	HT 23		
20	83.2 m	VR 23/25-29		
21	93.2 m	BT 29		
Substructure		KRF 16-80/100		
Corner distance [m x m]		10.0 x 10.0		
Substructure height [m]		3.3		
Tower height [m]		96.5		
Hook height double reeving [m]		98.0		
Hook height 4 fall operation [m]		97.6		
Wind category				C25

3 Tower combinations



3.5 Tower combinations on undercarriage (slewing section with UV 20 - connection)

Jib length	30 m – 65 m				
Elements					
1	4.5 m	UV 20.4	UV 20.4	UV 20.4	UV 20.4
2	9.0 m	UV 20.4	UV 20.4	UV 20.4	UV 20.4
3	13.5 m	UV 20.4	UV 20.4	UV 20.4	UV 20.4
4	18.0 m	UV 20.4	UV 20.4	UV 20.4	UV 20.4
5	22.5 m	UV 20.4	UV 20.4	UV 20.4	UV 20.4
6	27.0 m	UV 20.4	UV 20.4	UV 20.4	UV 20.4
7	31.5 m		UV 20.4	UV 20.4	UV 20.4
8	36.0 m			TVA 20.4	UV 20.4
9	40.5 m				TVA 20.4
Substructure		UW 260.1	UW 260.1	UW 260.2	UW 260.2
Corner distance [m x m]		5.0 x 6.79	6.0 x 6.0	5.0 x 6.79	6.0 x 6.0
Substructure height [m]		4.5	4.5	4.5	4.5
Tower height [m]		31.5	36.0	40.5	45.0
Hook height double reeving [m]		33.0	37.5	42.0	46.5
Hook height 4 fall operation [m]		32.6	37.1	41.6	46.1
Wind category		C25			

Jib length	30 m – 65 m				
Elements					
1	4.5 m	UV 20.4	UV 20.4	UV 20.4	
2	9.0 m	UV 20.4	UV 20.4	UV 20.4	
3	13.5 m	UV 20.4	UV 20.4	UV 20.4	
4	18.0 m	UV 20.4	UV 20.4	UV 20.4	
5	22.5 m	UV 20.4	UV 20.4	UV 20.4	
6	27.0 m	UV 20.4	UV 20.4	UV 20.4	
7	31.5 m	UV 20.4	UV 20.4	UV 20.4	
8	36.0 m	UV 20.4	UV 20.4	UV 20.4	
9	40.5 m	UV 20.4	UV 20.4	UV 20.4	
10	45.0 m	UV 20.4	UV 20.4	UV 20.4	
11	49.5 m	TVA 20.4	TVA 20.4	TVA 20.4	
12	54.0 m		TV 20.4	TV 20.4	
13	58.5 m			TV 20.4	
14	63.0 m			TVÜ 20.4	
15	67.5 m			UVA 25	
Substructure		UW 260.3	UW 260.3	UW 480	
Corner distance [m x m]		5.0 x 6.79	6.0 x 6.0	8.0 x 8.0	
Substructure height [m]		4.5	4.5	5.0	
Tower height [m]		54.0	58.5	72.5	
Hook height double reeving [m]		55.5	60.0	74.0	
Hook height 4 fall operation [m]		55.1	59.6	73.6	
Wind category		C25			

4 Foundation loads / central ballast weights / corner loads in compliance with EN 14439 / EN 13001

4 Foundation loads / central ballast weights / corner loads in compliance with EN 14439 / EN 13001

	<p style="text-align: center;">⚠ DANGER</p> <p>Usage of incorrect tower combinations. The slewing tower crane may overturn.</p> <ol style="list-style-type: none"> 1) Use the specified tower combinations. 2) If you need another tower combination that is not specified here, please contact WOLFFKRAN to get an approved alternative setup in writing.
	<p style="text-align: center;">NOTICE</p> <p>If you need foundation loads for tower combination with tower element TV 25 and UV 25, please contact WOLFFKRAN to get an approved alternative setup.</p>

Jib positions

The corner loads are given for two jib positions with the maximum corner load resulting from jib position 1.

For square setup, the following equation is true: $a = b$

For rectangular setup, the following equation is true: $a > b$

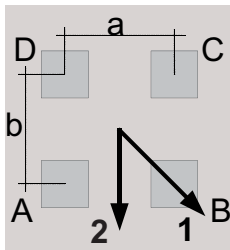

Cross frame or cross frame element

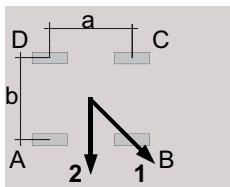

Undercarriage

NOTICE! For undercarriage details, please refer to the relevant operating manual.

Wind load with crane out of service

The stability for stormy weather is calculated on the basis of wind region C (EN 13001-2). The reference wind speed for zone C is 28 m/s (10 m above ground, averaged over 10 minutes). As a basis, a recurrence interval of 25 years is used. As a basis, a recurrence interval of 25 years is used.

4 Foundation loads / central ballast weights / corner loads in compliance with EN 14439 / EN 13001

Please contact WOLFFKRAN for stability calculations in other wind regions.

	NOTICE
	Die 4-Strang Hakenhöhe gilt nur für den Kran 6031.12 <i>clear</i> im 4-Strangbetrieb.

For information on the different substructures, refer to Section 5 of the Operating Manual.

4.1 Foundation loads jib 30 m - 65 m

Slewing section 6031 *clear* with 30 m – 65 m jib on foundation.
Slewing tower crane without climbing device.

Foundation load in compliance with EN 14439 / EN 13001 – typical loads

Includes all dynamical factors under consideration of second-order theory for stationary slewing tower cranes on concrete foundation in compliance with a tower combination without climbing device.

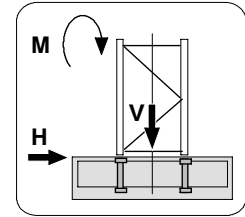



HH		Crane in service			Crane out of service			Assembly		
4	2	Slewing torque: 290 kNm			Wind category C25			M	V	H
STR	STR	M	V	H	M	V	H	M	V	H
[m]	[m]	[kNm]	[kN]	[kN]	[kNm]	[kN]	[kN]	[kNm]	[kN]	[kN]
5.6	6.0	1800	639	19	1420	498	29	1870	396	6
10.1	10.5	1890	667	21	1560	527	36	1900	424	7
14.6	15.0	2000	695	23	1740	555	42	1940	452	8
19.1	19.5	2120	724	25	1950	583	48	1990	481	9
23.6	24.0	2250	752	27	2190	612	54	2040	509	10
28.1	28.5	2390	780	29	2460	640	60	2100	537	11
32.6	33.0	2560	809	31	2770	668	66	2170	565	12
37.1	37.5	2740	837	33	3120	696	73	2250	594	13
41.6	42.0	2930	865	34	3500	725	79	2330	622	15
46.1	46.5	3140	894	36	3920	753	85	2430	650	16
50.6	51.0	3380	922	38	4380	781	91	2540	680	17
55.1	55.5	3640	950	40	5190	953	134	2650	707	18
59.6	60.0	3920	978	42	6110	981	145	2780	735	19
64.1	64.5	4240	1007	44	7140	1010	155	2920	763	20
68.6	69.0	4590	1035	46	8280	1038	165	3080	792	21
69.6	70.0	4500	961	43	7470	964	150	3010	718	19
74.1	74.5	4820	992	45	8550	994	161	3150	748	21
78.6	79.0	5090	1056	48	9650	1058	175	3270	812	22
83.1	83.5	5440	1095	50	10900	1098	186	3430	852	23
87.6	88.0	5810	1134	52	12280	1137	198	3590	891	25
89.9	90.3	5900	1180	54	12830	1183	206	3640	937	26
94.4	94.8	6320	1220	56	14390	1223	218	3820	976	27
Tower combination with base tower element BT 29										
98.8	99.2	6550	1286	59	15620	1289	234	3940	1043	29
103.3	103.7	6970	1332	62	17330	1335	248	4130	1089	30

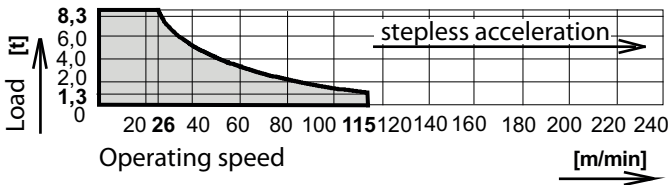

Caption

HH	Hook height	V:	Vertical load	STR:	Number of falls
H:	Horizontal load	M:	Torque		

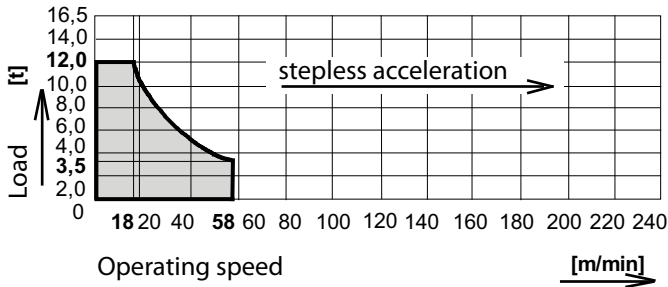
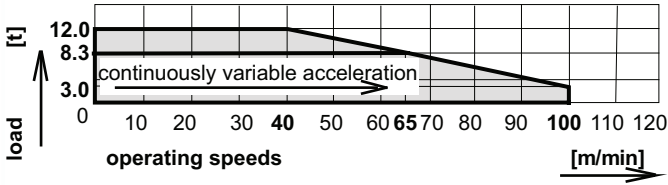
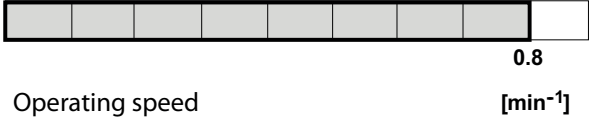
5 Operating speeds

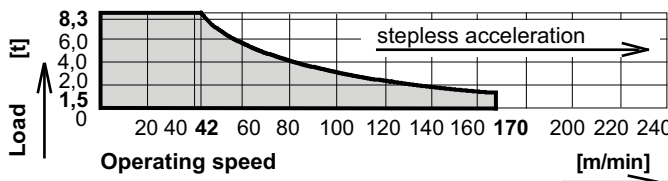

Drive unit [type]	Operating speed Carrying load	Hook travel distance max. [m]	Power [kW]	Total connected load [kVA]
Hw845FU	Lifting 	190	45	67.0 Total connected load at coincidence factor of 0.7
				
KW	Lifting 	95	7.5	
				
SG	Trolley movement		2x6.0	
				
SG	Slewing		0.8	
				

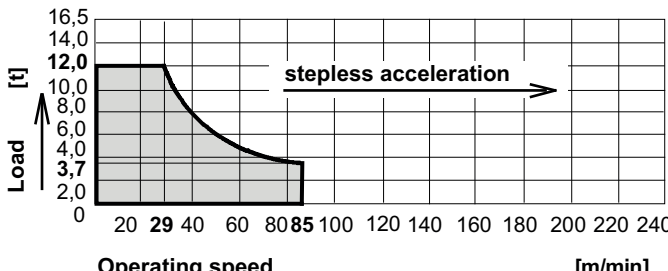
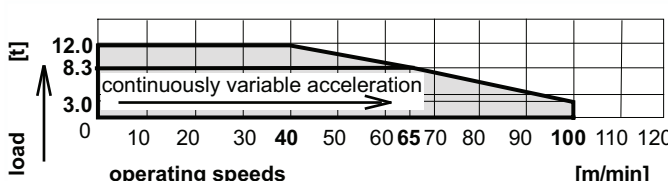
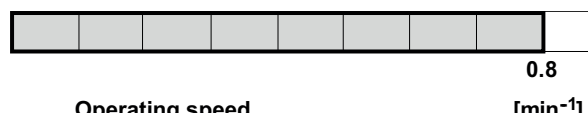
5 Operating speeds





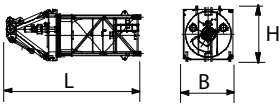
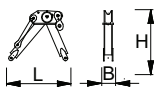
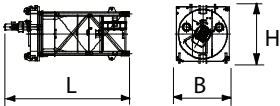
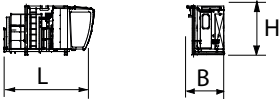
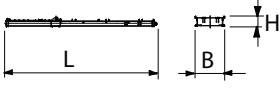
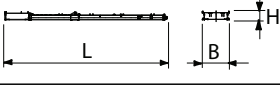
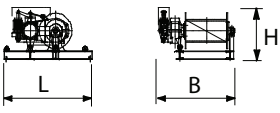
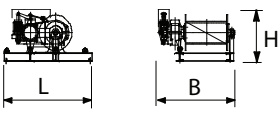

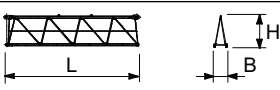
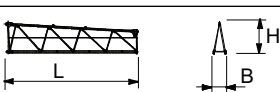

Drive unit [type]	Operating speed Carrying load	Hook travel distance max. [m]	Power [kW]	Total connected load [kVA]
Hw875FU	Lifting 	460	75	95.0 Total connected load at coincidence factor of 0.7
				
	Lifting 	230		
				
KW	Trolley movement		7.5	
				
SG	Slewing		2x6.0	
				

6 Package list

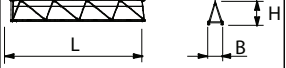
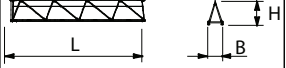
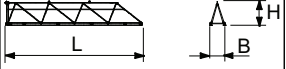
6.1 Package list 6031.12

Quantity	Description	Package	L [m]	W [m]	H [m]	Weight [kg]	Volume [m ³]	
1	Tower head section, complete with slewing frame, ball race bearing, slewing gear and slip ring system		with UV 20 / TV 20 lower part of tower head section					
			6.67	2.30	2.54	9370	38.97	
	Tower head section upper part with stay parts		2.33	0.58	2.81	1300	3.80	
	Tower head section lower part with slewing frame, ball race bearing, slewing gear and slip ring system		5.77	2.30	2.54	8070	33.71	
1	Driver's cab with driver's cab suspension		4.82	1.96	2.55	2580	24.10	
1	Counterjib with stay parts and standard railings		14.04	2.30	0.80	6840	25.84	
	Counterjib without ballast carrier and without loose items		11.87	2.30	0.70	5280	19.11	
1	Hoist winch platform Hw845FU (incl. 200 m hoisting rope)		2.17	1.57	1.04	2140	3.54	
1	Hoist winch platform Hw875FU (incl. 200 m hoisting rope)		2.17	1.88	1.18	2500	4.82	
1	Jib element 1 with traverse gear		10.34	1.20	2.38	3265	29.53	
1	Jib element 2		10.32	1.20	2.36	2150	29.23	
1	Jib element 3		10.29	1.20	2.34	1600	28.90	

6 Package list

Quantity	Description	Package	L [m]	W [m]	H [m]	Weight [kg]	Volume [m ³]
1	Jib element 4		5.27	1.20	1.74	775	11.0
1	Jib element 5		2.77	1.20	1.74	470	5.78
1	Jib element 6		10.25	1.20	1.72	1365	21.16
1	Jib element 7		10.07	1.20	1.70	1045	20.75
1	Jib element 8		10.17	1.20	1.70	800	20.75
1	Rope swivel cross-beam		0.99	1.09	0.45	126	0.49
1	Trolley LK 8/ 12		1.87	1.38	1.03	355	2.66
1	Maintenance cage		0.75	0.58	1.69	55	0.74
1	Hook block U 8/ 16 AU		1.02	0.27	1.84	550	0.51
1	Standard railings		2.60	1.10	0.65	300	1.86
1	Box (small parts)		0.63	0.50	0.38	100	1.12

7 Assembly weights

7.1 Counterweight blocks



NOTICE

The described diagrams of the concrete counterweights and central ballast blocks only show sketches. Have them issue the reinforcement charts by experts.

7 Assembly weights

7.1.1 Counterweight block, 2.7 t

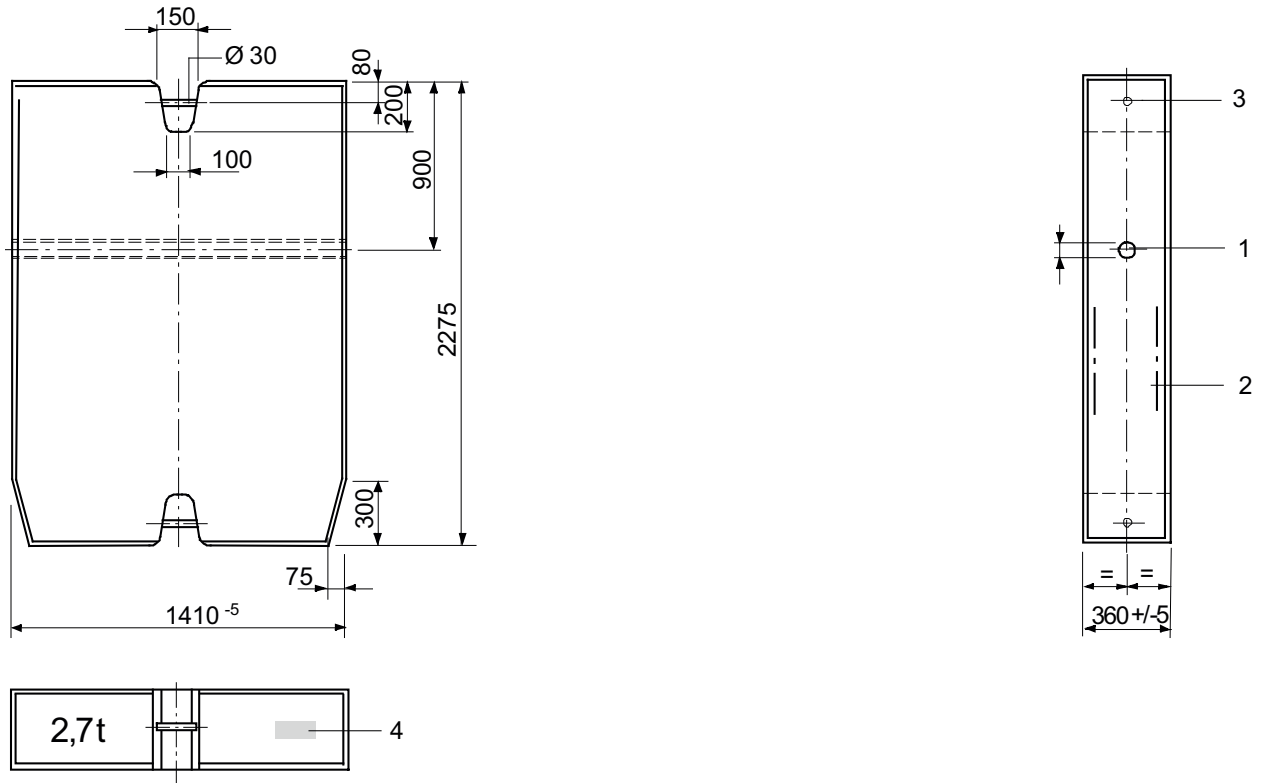

Data counterweight block 2.7 t

Item	Data
Material	Concrete, min. C 20/25
Max. permitted weight tolerance	+/- 3 %
Order number	30021887
1	Connection for stub shaft (Ø 40x 215 Item no.: 30024871)
2	Structural steel reinforcement
3	Suspension
4	Component identifier

7.1.2 Counterweight block, 3.7 t

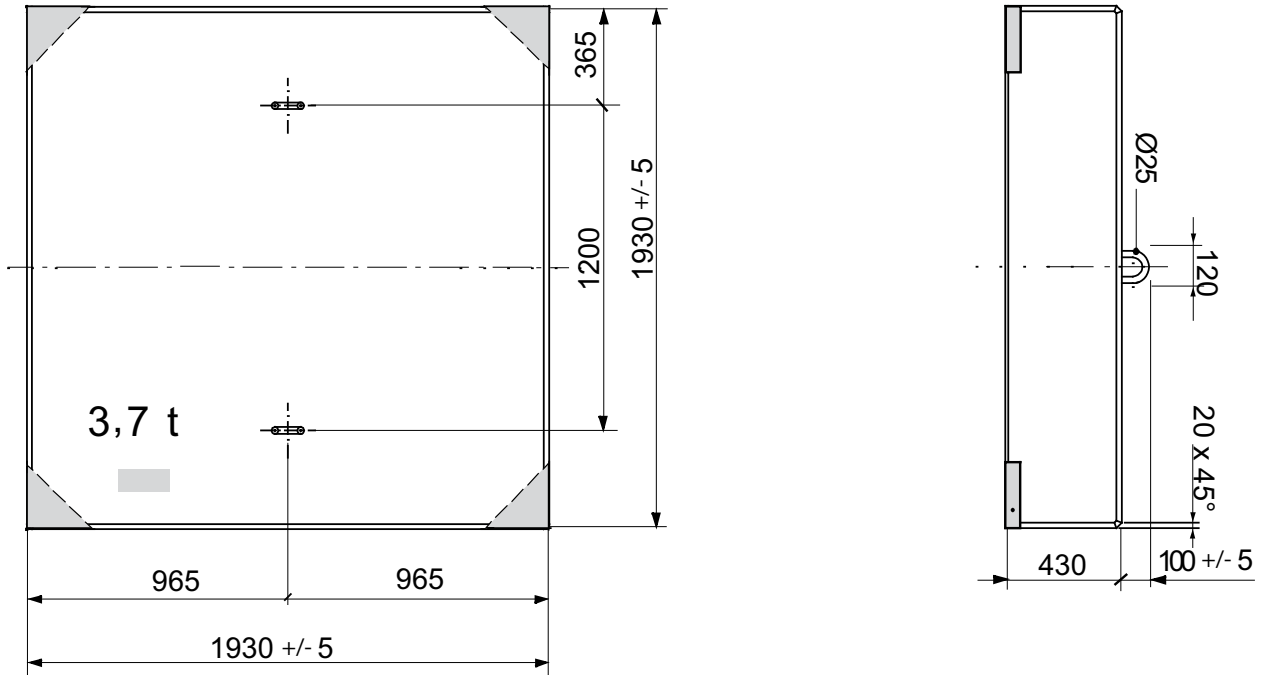

Data counterweight block 3.7 t

Item	Data
Material	Concrete, min. C 20/25
Max. permitted weight tolerance	+/- 3 %
Order number	962-2-029759
1	Corner guard
2	Suspension
3	Component identifier

7 Assembly weights

7.2 Total weight jib assembly

Trolley jib, complete: Trolley, trolley ropes, hook block, standard railings and rope swivel crossbeam

Jib length [m]	Weight [kg]	
	WOLFF 6031.8 clear	WOLFF 6031.12 clear
65.0	11800	12100
62.5	11500	11800
60.0	11000	11300
57.5	10900	11200
55.0	11000	11300
52.5	10700	11000
50.0	10200	10500
47.5	10100	10400
45.0	10000	10300
42.5	9700	10000
40.0	9200	9500
37.5	9100	9400
35.0	8600	8900
32.5	8300	8600
30.0	7800	8100

7.3 Assembly weight slewing section

Module	Crane parts	Weight [kg]	
Tower head section complete with brace plates and standard railings			9370
	▪ Tower head section upper part including brace plates	1300	
	▪ Tower head section lower part including slewing frame, ball race bearing, slewing gears, standard railings and slip ring system	8070	
Operator cabinet platform, complete			2580
	▪ Driver's cab including control cabinet, resistor and driver's cab suspension		
Counter jib with Hw845FU, complete			12575
	▪ Counterjib with brace plates, standard railings and ballast frame	6840	
	▪ Hoist winch platform Hw845FU	2035	
	▪ Concrete counterweight block 3.7 t (below hoist winch platform)	3700	
Counter jib with Hw875FU, complete			12915
	▪ Counterjib with brace plates, standard railings and ballast frame	6840	
	▪ Hoist winch platform Hw875FU	2375	
	▪ Concrete counterweight block 3.7 t (below hoist winch platform)	3700	

7 Assembly weights

7.4 Assembly weight cross frame

Module	Crane parts	Weight [kg]
Cross frame KR 6-40 (without accessories)		
(4.0 m x 4.0 m)	▪ 4 bolted spigots AZ 93.4	200
	▪ 4 bolted spigots AZ 93.4 E 15	240
Cross frame KR 7-32 (without accessories)		
(3.2 m x 3.2 m)	▪ 4 bolted spigots AZ 85 E 20.5	210
	▪ 4 bolted spigots AZ 93.4 E 15	240
	▪ 4 bolted spigots AZ 120 M	292
Cross frame KR 7 - 32 (without accessories)		
(3.2 m x 3.2 m)	▪ 4 bolted spigots AZ 85 E 20.5	210
	▪ 4 bolted spigots AZ 93.4 E 15	240
	▪ 4 bolted spigots AZ 120 M	292
Cross frame KR 7 - 32/46 (without accessories)		
(4.6 m x 4.6 m)	▪ 4 bolted spigots AZ 85 E 20.5	210
	▪ 4 bolted spigots AZ 93.4 E 15	240
	▪ 4 bolted spigots AZ 120 M	292
Cross frame KR 8- 46 (without accessories)		
(4.6 m x 4.6 m)	▪ 4 bolted spigots AZ 85 E 20.5	210
	▪ 4 bolted spigots AZ 93.4 E 15	240
	▪ 4 bolted spigots AZ 120 M	292
Cross frame KR 10- 46 (without accessories)		
(4.6 m x 4.6 m)	▪ 4 bolted spigots AZR 120 E 15.5	552
	▪ 4 bolted spigots AZ 140 M	698
Cross frame KR 16 - 46/ 60 (without accessories)		
(6.0 m x 6.0 m)	▪ 4 bolted spigots AZR 120 E 15.5	552
	▪ 4 bolted spigots AZ 140 M	698
Cross frame KR HEB 700 - 4 (without accessories)		
(4.0 m x 4.0 m)	▪ 4 bolted spigots AZ 93.4	240
Cross frame KR HEB 700 - 5 (without accessories)		
(5.0 m x 5.0 m)	▪ 4 bolted spigots AZ 93.4	240
Cross frame KR HEB 800 - 5 (without accessories)		
(5.0 m x 5.0 m)	▪ 4 bolted spigots AZ 120 M	292
Cross frame KR HEB 800 - 6 (without accessories)		
(6.0 m x 6.0 m)	▪ 4 bolted spigots AZ 120 M	292
Supporting frame SR 150 (without accessories)		
(4.0 m x 4.0 m)	▪ 4 bolted spigots AZ 85 E 20.5	210

Module	Crane parts	Weight [kg]	
	▪ 4 bolted spigots AZ 93.4 E 15	240	
	▪ 4 bolted spigots AZ 120 M	292	
Cross frame KR 1000- 8 (without accessories)			14 630
(8 m x 8 m)	▪ 4 bolted spigots AZ 140 E	684	
	▪ 4 bolted spigots AZ 156 M	748	
Cross frame KR 16- 80 (without accessories)			21 450
(8 m x 8 m)	▪ 4 bolted spigots AZ 140 E KR 16-80	620	
	▪ 4 bolted spigots AZ 156 M KR 16-80	680	
	▪ 4 bolted spigots AZ 156S M KR 16-80	675	
Cross frame KR 16 - 80 / 100 (without accessories)			25 400
(10 m x 10 m)	▪ 4 bolted spigots AZ 140 E KR 16-80	620	
	▪ 4 bolted spigots AZ 156 M KR 16-80	680	
	▪ 4 bolted spigots AZ 156S M KR 16-80	675	

7 Assembly weights

7.5 Assembly weights traveling cross frame

Module	Crane parts	Weight [kg]
Mobile cross frame KRF 10 – 46/60 complete		17500
(6.0 m x 6.0 m)	▪ Cross frame	7000
	▪ Drive gear corners	2385
	▪ Backing braces	1510
	▪ Subframe	5645
	▪ Platforms + ladders	510
	▪ Control cabinet	130
	▪ small items	320
	▪ Set of bolted spigots AZ 120 E 15.5 KRF 10-46/60	605
	▪ Set of bolted spigots AZR 140 M KRF 10-46/60	760
Traveling cross frame KRF4 12-60/80 complete		32300
(8.0 m x 8.0 m)	▪ Cross frame	14170
	▪ Backing braces	2875
	▪ Drive gear corners	4560
	▪ Subframe	9380
	▪ Platforms and ladders	255
	▪ Control cabinet	130
	▪ small items	930
	▪ Set of bolted spigots AZR 140 M KR 12-60/80	790
	▪ Set of bolted spigots AZ 120 E 15,5 KR 12-60/80	730
	▪ Set of bolted spigots AZ 140 E 15,5 KR 12-60/80	875
	▪ Set of bolted spigots AZR 160 M KR 12-60/80	905
	▪ Set of bolted spigots AZ 140 E 10 KR 12-60/80	790
	▪ Set of bolted spigots AZR 156 M KR 12-60/80	845
Traveling cross frame KRF6 12-60/80 complete		41200
(8.0 m x 8.0 m)	▪ Cross frame	14170
	▪ Backing braces	2875
	▪ Drive gear corners	4560
	▪ Subframe	18270
	▪ Platforms and ladders	255
	▪ Control cabinet	130
	▪ small items	940
	▪ Set of bolted spigots AZR 140 M KR 12-60/80	790

Module	Crane parts	Weight [kg]
	▪ Set of bolted spigots AZ 120 E 15,5 KR 12-60/80	730
	▪ Set of bolted spigots AZ 140 E 15,5 KR 12-60/80	875
	▪ Set of bolted spigots AZR 160 M KR 12-60/80	905
	▪ Set of bolted spigots AZ 140 E 10 KR 12-60/80	790
	▪ Set of bolted spigots AZR 156 M KR 12-60/80	845
Mobile cross frame KRF 16 – 80/100 complete		49530
(10.0 m x 10.0 m)	▪ Cross frame KR 16-80/100 with traversing gear corners	26980
	▪ Drives	19000
	▪ Backing braces	3450
	▪ small items	100
	▪ Set of bolted spigots AZ 140 E KR 16-80	620
	▪ Set of bolted spigots AZ 156 M KR 16-80	680
	▪ Set of bolted spigots AZ 156S M KR 16-80	675
	▪ Set of bolted spigots AZ 160 M KR 16-80	1135
	▪ Set of bolted spigots AZ 210 M KR 16-80	3015

7 Assembly weights

7.6 Assembly weight cross frame elements

Module	Crane parts	Weight [kg]	
Cross frame element KRE 138, complete			3 800
	▪ Cross frame platform with lifting beam, corner plates and transport locks	2 100	
	▪ Mast base with diagonal struts	1 700	
Cross frame element KRE 250 complete			5 750
	▪ Cross frame platform with hinged section, corner plates and transport locks	2 730	
	▪ Mast base with diagonal struts and tie rods	3 020	
Cross frame element KRE 260.1, complete			8 100
	▪ Cross frame platform with hinged section, corner plates and transport locks	4 320	
	▪ Mast base with diagonal struts and tie rods	3 780	
Cross frame element KRE 260.2, complete			10 900
	▪ Cross frame platform with hinged section, corner plates and transport locks	5 455	
	▪ Mast base with diagonal struts and tie rods	5 445	
Cross frame element KRE 480 complete			24 250
	▪ Mast base	7 100	
	▪ Hinged sections with corner plates	6 250	
	▪ Diagonal struts and ballast carrier	9 260	
	▪ Assembly platform, ladder, and small parts	1 640	

7.7 Assembly weight undercarriage

Module	Crane parts	Weight [kg]	
Bogie truck UW 138, complete			
	▪ Undercarriage platform with mounting device, spacers and subframes	3 970	
	▪ Mast base with diagonal struts	1 780	
Undercarriage UW 250, complete			
	▪ Undercarriage platform with hinged sections, subframes and transport locks	5 600	
	▪ Mast base with diagonal struts and tie rods	3 200	
Undercarriage UW 260.1, complete			
	▪ Undercarriage platform with hinged sections, subframes and transport locks	7 150	
	▪ Mast base with diagonal struts and tie rods	4 250	
Undercarriage UW 260.2, complete			
	▪ Undercarriage platform with hinged sections, subframes and transport locks	9 810	
	▪ Mast base with diagonal struts and tie rods	4 250	
Undercarriage UW 260.3, complete			
	▪ Undercarriage platform with hinged sections, subframes and transport locks	11 300	
	▪ Mast base with diagonal struts and tie rods	5 900	
Undercarriage UW 480, complete			
	▪ Mast base	7 100	
	▪ Hinged sections with mounting device and subframes	16 000	
	▪ Diagonal struts and ballast carrier	9 260	
	▪ Assembly platform, ladder, and small parts	1 640	

7 Assembly weights

7.8 Required hook height for mobile cranes

For information about the height of the WOLFF slewing tower crane, refer to Tower combinations [11].

NOTICE! During assembly, allowances must be made for level differences (mobile crane to base of the slewing tower crane).

Hook height above ground required for mobile cranes (X) = height of the WOLFF slewing tower crane (A) + clearance of 12 m (B).

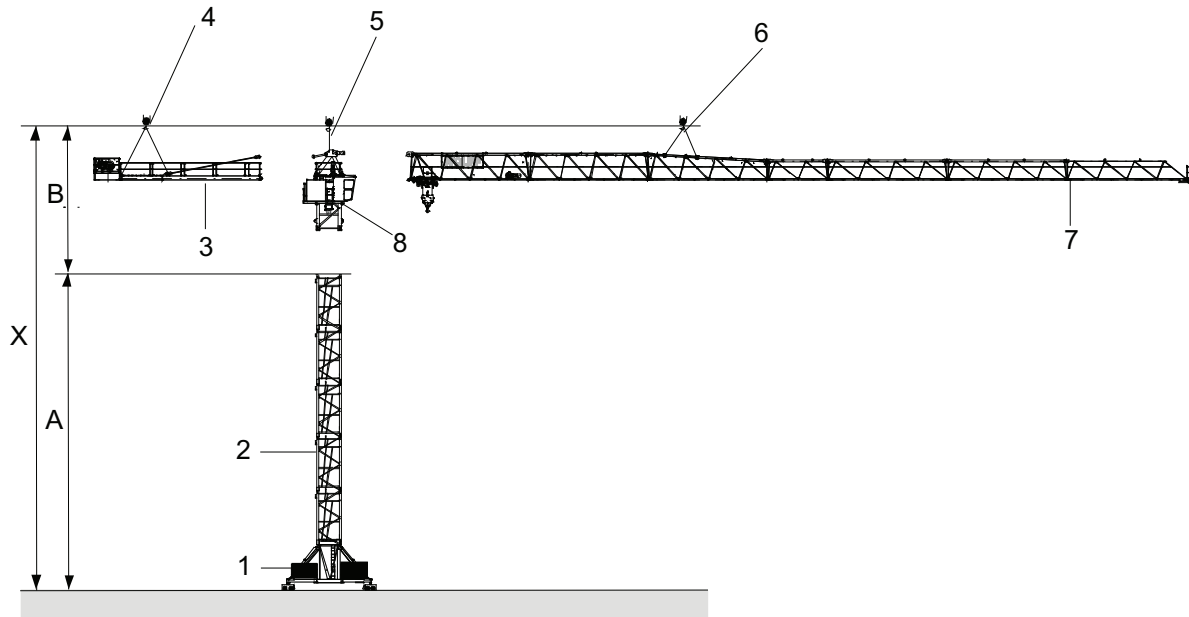

Exemplary illustration

[A]	Height of the WOLFF slewing tower crane	[B]	Clearance 12 m
[X]	Hook height above ground required for the mobile crane		
1	Undercarriage	5	Single-point lifting tackle (2 m with shackle)
2	Tower element	6	4-fall attachment (4 m with shackle)
3	Counterjib, complete	7	Jib, complete
4	Four-point lifting tackle (with shackle)	8	Tower head section, complete

(see also):

- Tower combinations [11]

8 Assembly diagrams

8.1 Jib attachment diagram

	NOTICE
	For jib assembly, use a 4-fall attachment (4 m with shackle).

	NOTICE
	To install the snatch block within two sling ropes to DIN 3088 (Ø 8 mm x 1 m with shackle), attach it to the trolley, reeve in the mounting rope (Perlon, Ø 14 mm x 12 m) and secure it on the trolley.

Length of jib elements

Item	Length [m]
Slewing trolley jib element 1, 2, 3, 6, 7, 8	10.0
Trolley jib element 4	5.0
Trolley jib element 5	2.5
Rope swivel crossbeam	0.51

8 Assembly diagrams

8.1.1 Slewing Trolley Jib Lifting Diagram 65 m to 55 m (6031.12 clear)

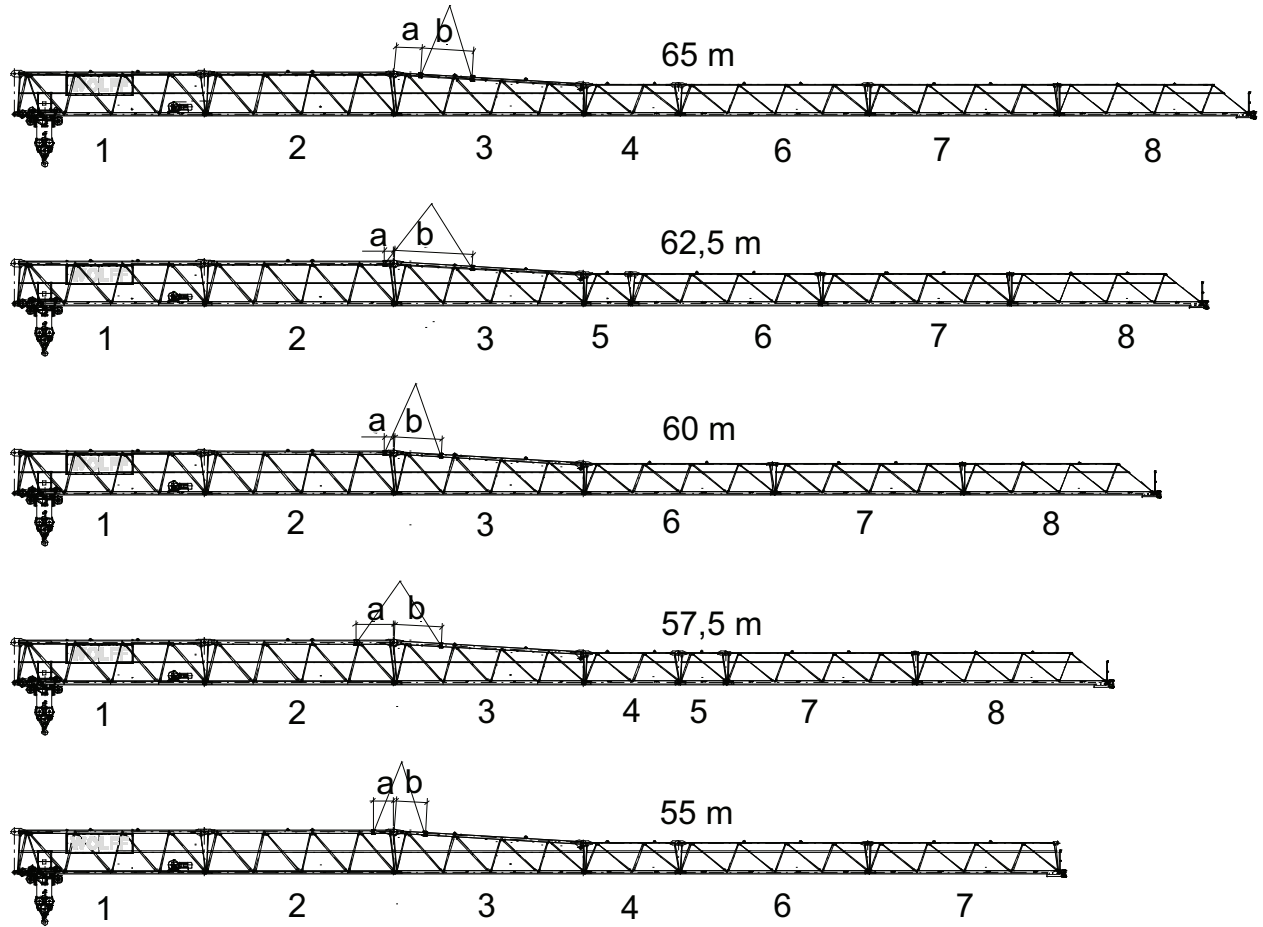

a	Dimension a
b	Dimension b

Data	Jib length [m]				
	65	65.5	60	57.5	55
a [mm]	1404	495	495	2016	1085
b [mm]	2734	4138	2469	2469	1634
Weight [kg] 6031.12 clear	12100	11800	11300	11200	11300

8.1.2 Slewing Trolley Jib Lifting Diagram 52.5 m to 42.5 m (6031.12 clear)

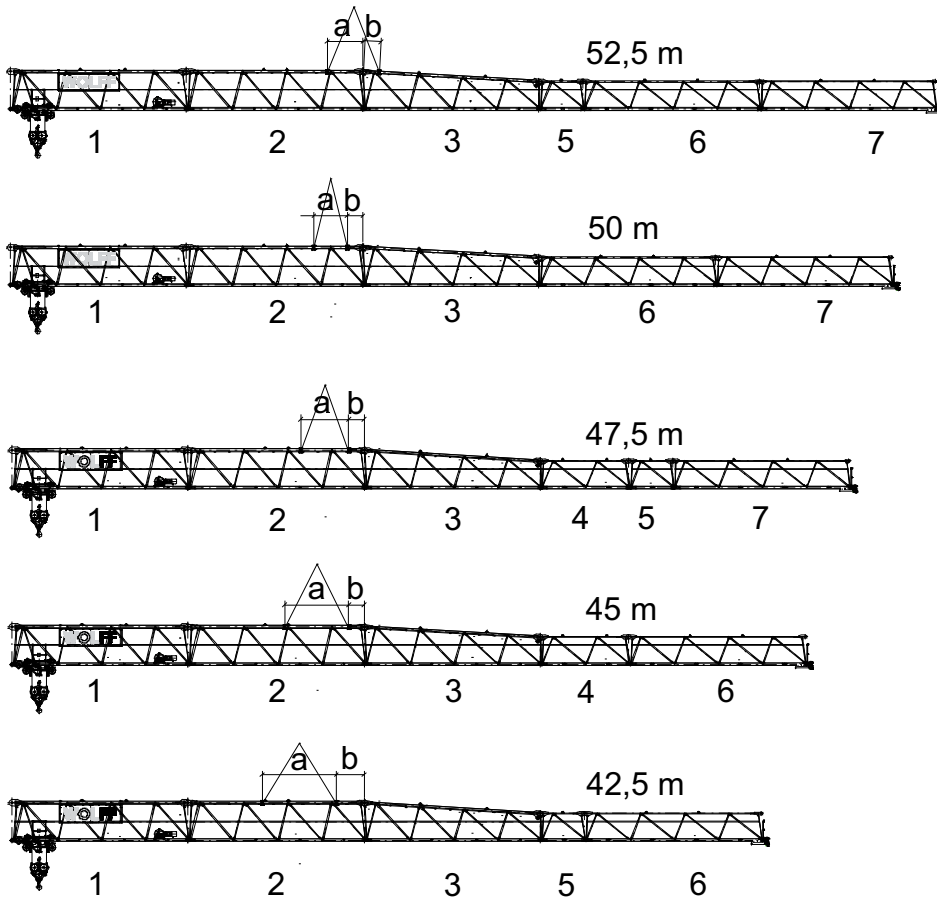

a	Dimension a
b	Dimension b

Data	Jib length [m]				
	52.5	50	47.5	45	42.5
a [mm]	2016	897	2730	3662	4209
b [mm]	934	855	855	855	1564
Weight [kg] 6031.12 clear	11000	10500	10400	10300	10000

8 Assembly diagrams

8.1.3 Slewing Trolley Jib Lifting Diagram 40 m to 30 m (6031.12 clear)

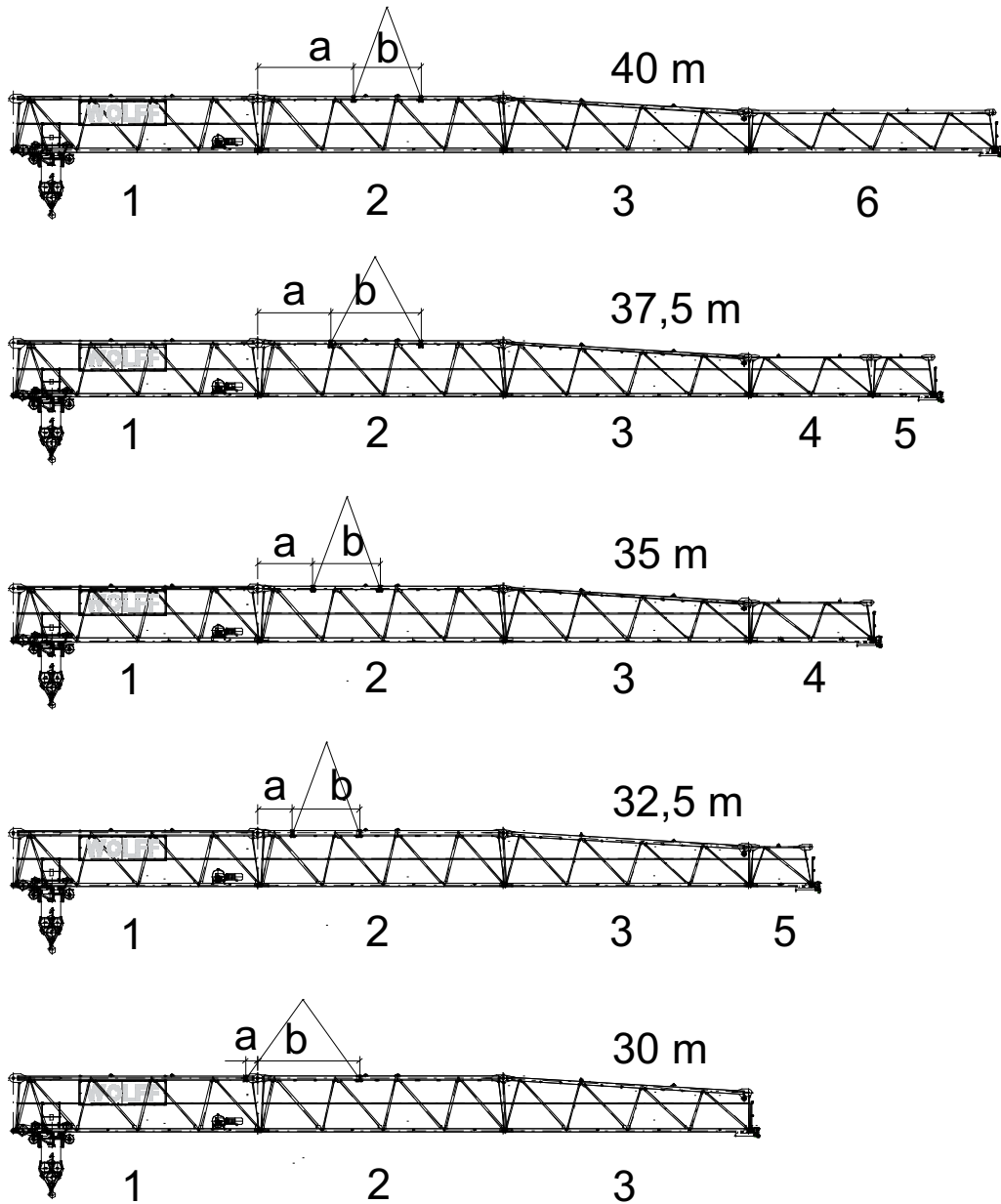

a	Dimension a
b	Dimension b

Data	Jib length [m]				
	40	37.5	35	32.5	30
a [mm]	3897	2965	2231	1397	515
b [mm]	2730	3662	2730	2730	4127
Weight [kg] 6031.12 clear	9500	9400	8900	8600	8100

8.2 Trolley jib mounting rig

	NOTICE
	<p>For information on the arrangement of the mounting rig, refer to the attachment diagram.</p> <p>Two mounting rigs are required per slewing tower crane.</p>

Elements required for each mounting rig

Quantity	Item	Dimensions	Material
1	Mounting rig		
4	Hexagonal head bolt	M16 x 240	ISO 4017-8.8 galv.
8	HSFG washer	17	EN 14399 galvanized
8	Hexagonal nut	M16	ISO 4032-8 galvanized

Mounting rig

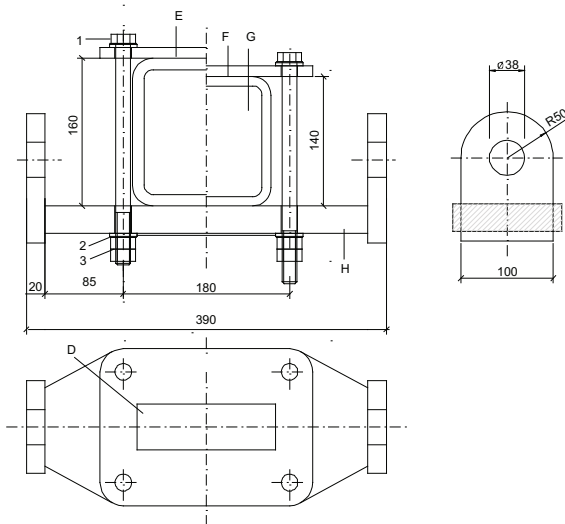

1	Hexagonal head screw	A	Mounting rig
2	HSFG washer	B	Top chord trolley jib
3	Hexagonal nut		

8 Assembly diagrams

8.3 Arrangement of standard railings

8.3.1 Standard railings (NG) and accessories

Quantity *	Standard railings (NG)
3	Standard post (NP)
1	F * (flag pole mount)
5	Standard railing 500
2/ 1*	Standard railing 750
4	Standard railing 1000
3/ 4*	Standard railing 2000
8	Standard railing 2500
1	RS (hoop guard)
* HW875FU/ HW845FU	

8.3.2 Arrangement of standard railings

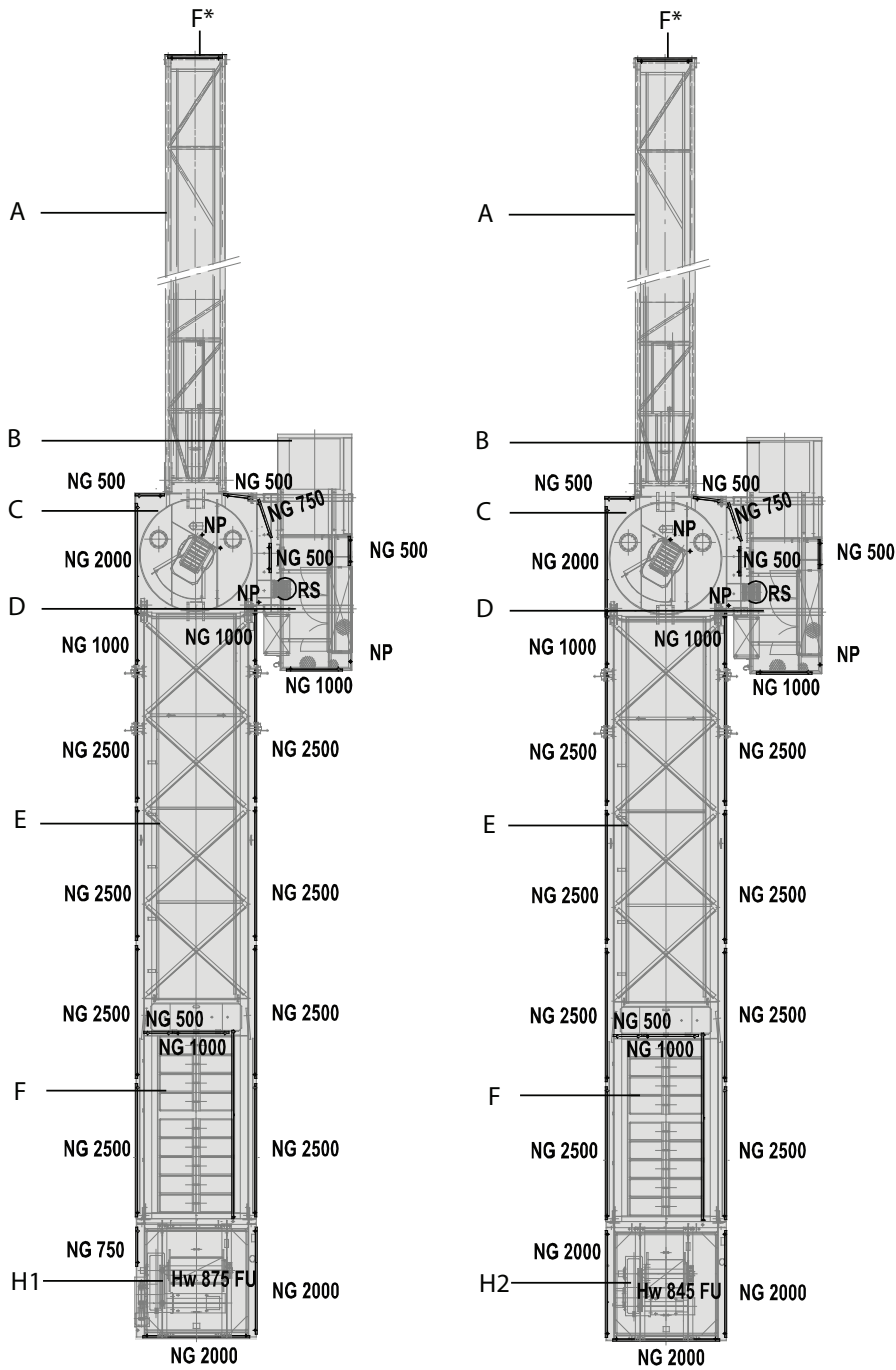

Arrangement of standard railings

A	Trolley jib	F	Counterweights
B	Driver's cab	H1	Hoist winch Hw875FU
C	Cat head pedestal	H2	Hoist winch Hw845FU
D	Control cabinet		

8 Assembly diagrams

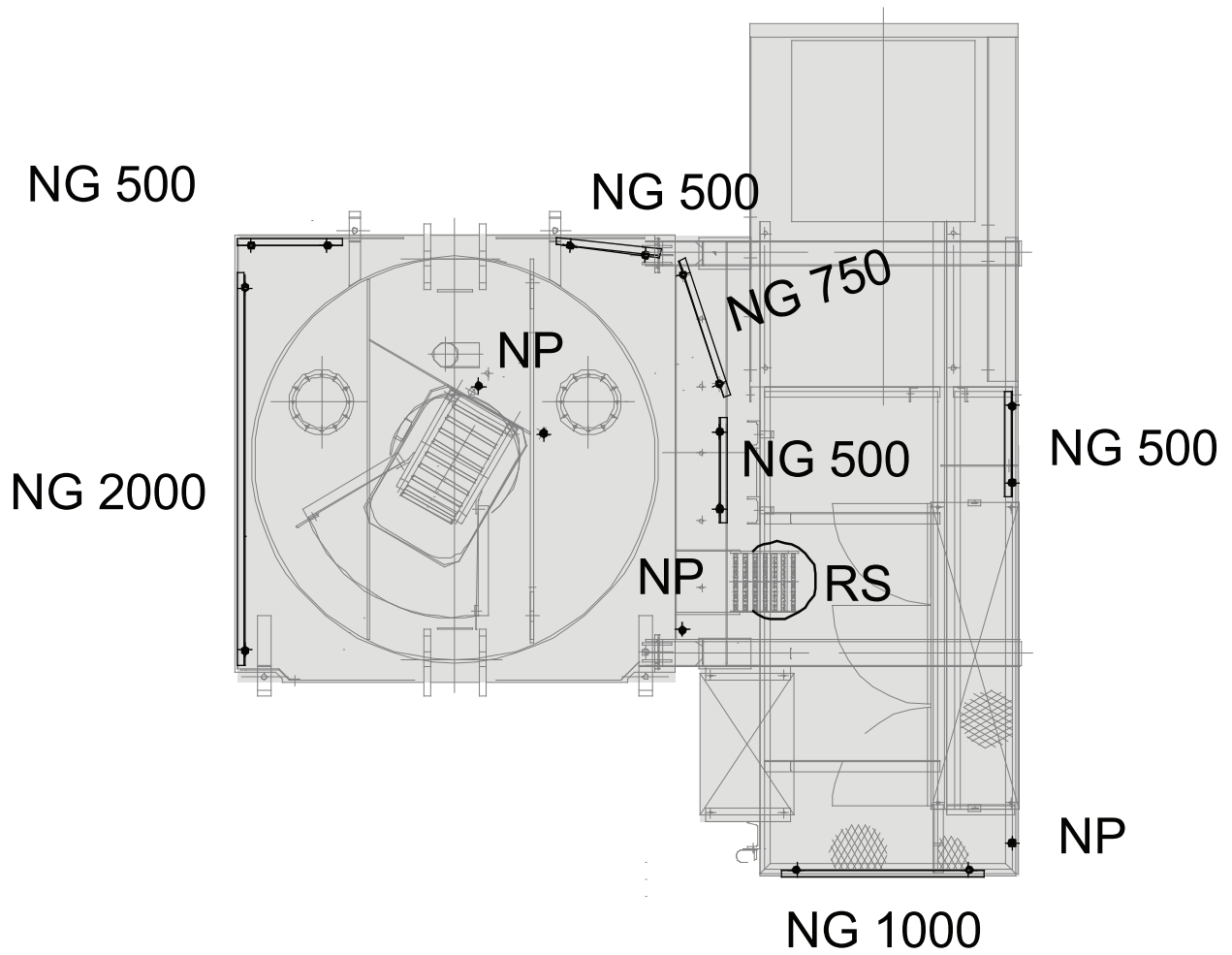

Arrangement of standard railings, tower head section

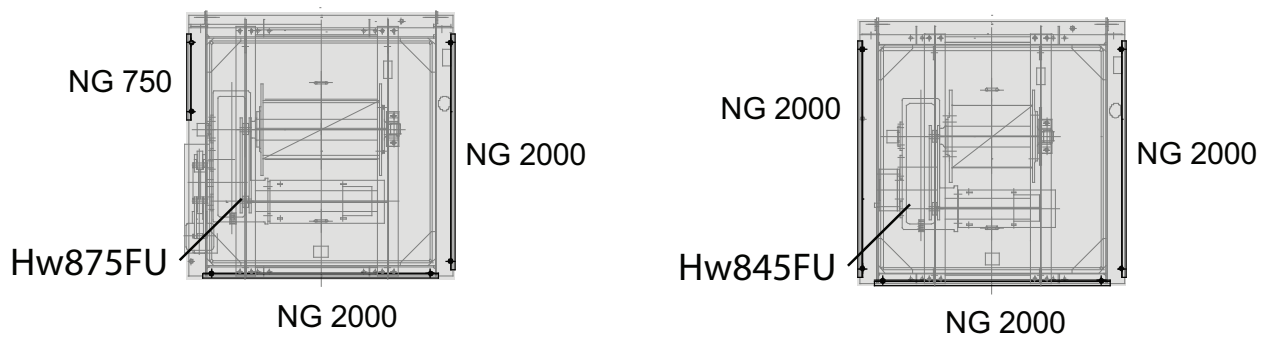





Arrangement of standard railings hoist winch

9 Suitable climbing devices



This section contains information on

- Outer climbing devices (KWH)
- Inner climbing devices (KSH)

	<p style="text-align: center;">NOTICE</p> <p>Details on the climbing device Always refer to the details in the documentation of the climbing device.</p>
	<p style="text-align: center;">NOTICE</p> <p>The operating radius specified is measured from the tower center and is to be considered a reference value. Exact balancing can be achieved by changing the operating radius with the tower elements or loads specified in the table.</p>
	<p style="text-align: center;">NOTICE</p> <p>Details for climbing balancing The climbing balancing details apply to the snatch block in maximum hook position.</p>
	<p style="text-align: center;">NOTICE</p> <p>If feasible, preferably operate your climbing device without balancing weight.</p>

9 Suitable climbing devices

9.1 Outer climbing devices

	<p style="text-align: center;">! DANGER</p> <p>Climbing device attached to the lower part of the tower head section lower part.</p> <p>Increased wind surface. The slewing tower crane may overturn.</p> <ul style="list-style-type: none">▶ Dismantle the climbing device after the climbing procedure is finished or lower the climbing device down on the ground or lower the climbing device down to the uppermost tower brace.
	<p style="text-align: center;">NOTICE</p> <p>Tower element on the transfer carriage</p> <p>The data on climbing balance was specified under the assumption that a tower element is on the transfer carriage.</p>

9.1.1 Outer climbing device KWH 20.3 / KWH 20.3.1

Climbing radius for the balancing weights

6031.12	Jib length [m]														
	65	62.5	60	57.5	55	52.5	50	47.5	45	42.5	40	37.5	35	32.5	30
without Weight	21.3	37.5	36.6	45.5	42.5	-	-	-	-	-	-	-	-	-	-
UV 20 = 1.95 t	7.1	13.1	12.8	16.1	14.9	19.9	18.9	20.9	23.2	20.9	25.0	21.6	23.4	26.9	25.7
TV 20 = 3.05 t	-	9.1	8.9	11.4	10.6	14.4	13.7	15.2	17.0	15.2	18.4	15.8	17.2	20.0	19.0

9 Suitable climbing devices

9.1.2 Außenkletterwerk KWH 20.6 / KWH 20.6.1 / KWH 20.6.2

Climbing radius for the balancing weights

6031.12	Jib length [m]														
	65	62.5	60	57.5	55	52.5	50	47.5	45	42.5	40	37.5	35	32.5	30
no weight	19.4	35.5	34.7	43.6	40.5	-	-	-	-	-	-	-	-	-	-
UV 20 = 1.95 t	6.4	12.4	12.0	15.3	14.2	19.1	18.2	20.2	22.4	20.2	24.2	20.9	22.7	26.2	25.0
TV 20 = 3.05 t	-	8.6	8.3	10.9	10.0	13.9	13.1	14.7	16.5	14.7	17.9	15.2	16.7	19.4	18.5

9.2 Inner climbing devices

	NOTICE
	The data required and the instructions for tower assemblies with inner climbing device is available in the separate description of the inner climbing device.

DANGER! Observe the special tower combination for the inner climbing device.

	NOTICE
	Clamping forces for the inner climbing device (KSH) are specified based on a building height of < 250m and wind category C 25.

9 Suitable climbing devices

9.2.1 Inner climbing device KSH 20 SH

Tower combinations for slewing tower cranes with inner climbing device.

Item				
1	UV 20.4	UV 20.4	UV 20.4	UV 20.4
2	UV 20.4	UV 20.4	UV 20.4	UV 20.4
3	UV 20.4	UV 20.4	UV 20.4	UV 20.4
4	UV 20.4	UV 20.4	UV 20.4	UV 20.4
5	UV 20.4	UV 20.4	UV 20.4	UV 20.4
6	UV 20.4	UV 20.4	UV 20.4	UV 20.4
7	TVA 20.4	UV 20.4	UV 20.4	UV 20.4
8		TVA 20.4	UV 20.4	UV 20.4
9			TVA 20.4	UV 20.4
10				TVA 20.4
inner climbing device	KSH 20 SH	KSH 20 SH	KSH 20 SH	KSH 20 SH
Foundation anchors	FUA TYPE FS-156 / FUA 156S	FUA TYPE FS-156 / FUA 156S	FUA TYPE FS-156 / FUA 156S	FUA TYPE FS-156 / FUA 156S
Tower height [m]	46.5	51.0	55.5	60.0
Hook height (4 fall operation) [m]	47.6	52.1	56.6	61.1

Climbing radius [m] for the balancing weights

6031.12	Jib length [m]														
	65	62.5	60	57.5	55	52.5	50	47.5	45	42.5	40	37.5	35	32.5	30
UV 20.4 = 2.05 t	34.5	40.3	38.8	42.1	41.0	45.8	43.7	-	-	-	-	-	-	-	-
TV 20.4 = 2.98 t	27.0	31.6	30.4	32.9	32.1	35.9	34.2	35.7	37.5	34.8	-	-	-	-	-
Weight = 5.00 t	18.1	21.1	20.1	22.1	21.5	24.0	22.9	23.9	25.1	23.3	25.3	23.0	23.9	25.7	24.4

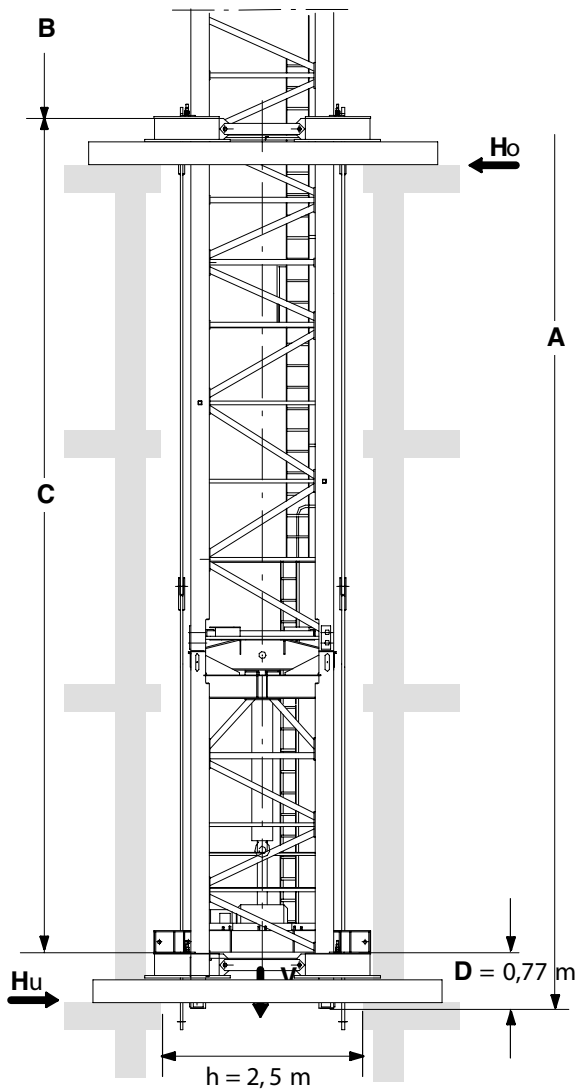

$$C_{\min} = 11,0 \text{ m}$$

$$C_{\max} = 14,0 \text{ m}$$

$$H_o = \frac{M}{C} + H$$

$$H_u = H_o - H$$

$$T = \frac{M_D}{2 \times b}$$

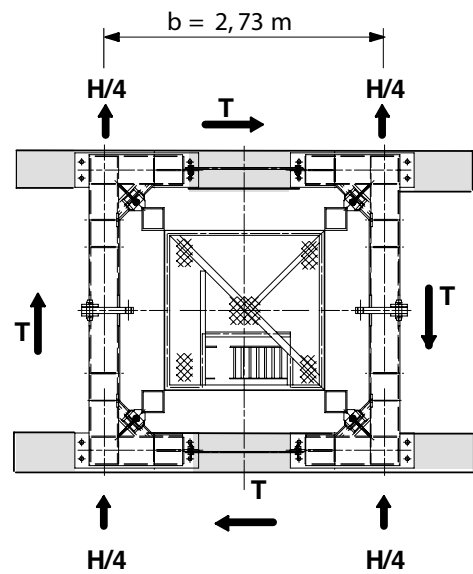

A	Tower height	C	Distance between guide frames
B	A-C-D		

9 Suitable climbing devices

Einspannkräfte in Betrieb

Einspannkräfte im Gebäude [kN] in Betrieb																
A [m]	60				55,5				51				46,5			
C [m]	11	12	13	14	11	12	13	14	11	12	13	14	11	12	13	14
V	1132				1113				1094				1075			
Ho	340	310	290	270	320	290	270	250	300	270	250	230	280	260	240	220
Hu	300	270	250	230	280	250	230	210	260	240	220	200	240	220	200	180
T	52				52				52				52			

Einspannkräfte außer Betrieb

Einspannkräfte im Gebäude [kN] außer Betrieb																
A [m]	60				55,5				51				46,5			
C [m]	11	12	13	14	11	12	13	14	11	12	13	14	11	12	13	14
V	100				981				962				943			
Ho	760	700	640	600	670	610	570	530	590	540	500	460	510	470	430	400
Hu	530	470	420	370	450	400	350	310	380	330	290	260	310	270	240	210
T	0				0				0				0			

10 Arrangement of counterweight blocks

L = 65 m	L = 62.5 m	L = 60 m	L = 57.5 m	L = 55 m
9 x 2.7 t	9 x 2.7 t	8 x 2.7 t	8 x 2.7 t	8 x 2.7 t
W = 28.0 t	W = 28.0 t	W = 25.3 t	W = 25.3 t	W = 25.3 t
L = 52.5 m	L = 50 m	L = 47.5 m	L = 45 m	L = 42.5 m
8 x 2.7 t	7 x 2.7 t	7 x 2.7 t	7 x 2.7 t	6 x 2.7 t
W = 25.3 t	W = 22.6 t	W = 22.6 t	W = 22.6 t	W = 19.9 t
L = 40 m	L = 37.5 m	L = 35 m	L = 32.5 m	L = 30 m
6 x 2.7 t	5 x 2.7 t	5 x 2.7 t	5 x 2.7 t	4 x 2.7 t
W = 19.9 t	W = 17.2 t	W = 17.2 t	W = 17.2 t	W = 14.5 t

Additional permanent counterweight for all jib lengths: 3.7 t

L	Jib length [m]	a	To the tower
G	Total weight [t]		Counterweight
	No counterweight		

WOLFFKRAN Group

Headquarter international:

WOLFFKRAN AG

Baarermattstraße 6

CH-6300 Zug

Switzerland

Phone +41 41 766 85 00

Fax +41 41 766 85 99

info@wolffkran.com

Manufacturing:

WOLFFKRAN GmbH

Austraße 72

D-74076 Heilbronn

Germany

Phone + 49 7131 9815 0

Fax + 49 7131 9815 355

info@wolffkran.de

WOLFFKRAN Werk Brandenburg GmbH

Frederik-Ipsen-Straße 5

D-15926 Luckau OT Altno

Germany

Phone + 49 35456 674 0

Fax + 49 35456 674 200

info@wolffkran.de