



# LT-56/62

Telescopic Aerial Device



# DEMAND BETTER

180° Platform Rotation

Non-Insulated Aluminum Inner Boom for increased payload and less wear and tear on chassis



State of the Art OEM Controls



- Working Height: Up to 68' 11"
- Reach: Up to 31'
- Platform Capacity: Up to 440 lbs.



For more information about the LT-56/62 or any of the other outstanding VERSALIFT machines, contact your authorized VERSALIFT Distributor or call 1-800-825-1085.



# LT-56/62

## Telescopic Aerial Device

### GENERAL AERIAL SPECIFICATIONS

	LT-56	LT-62
Height to Bottom of Platform	57 ft. 11 in. (17.65 m)	63 ft. 11 in. (19.48 m)
Working Height	62 ft. 11 in. (19.18 m)	68 ft. 11 in. (21.0 m)
Max. Horizontal Reach w/350 lbs.	31 ft. (9.45 m)	31 ft. (9.45 m)
Max. Horizontal Reach w/440 lbs.	27 ft. 10 in. (8.48 m)	27 ft. 10 in. (8.48 m)
Stowed Travel Height (approx.)	11 ft. 11 in. (3.63 m)	11 ft. 11 in. (3.63 m)
Max. Platform Capacity	440 lbs. (200 kg) / 350 lbs. (159 kg)	440 lbs. (200 kg) / 350 lbs. (159 kg)
Weight of Lift (w/o Subframe Mounting)	2,380 lbs. (1080 kg)	2,450 lbs. (1110 kg)

### BOOM ARTICULATION

Outer Boom Travel	-23° to +85°	-23° to +85°
Boom Extension	27 ft. 6 in. (8.4 m)	31 ft. 4 in. (9.6 m)
Boom Rotation	360° Continuous	360° Continuous
Platform Rotation	180°	180°

### HYDRAULIC SYSTEM

Hydraulic Operating Pressure	2,250 psi (158 kg/cm <sup>2</sup> )	2,250 psi (158 kg/cm <sup>2</sup> )
Hydraulic Flow Rate	3 gpm (11.4 lpm)	3 gpm (11.4 lpm)
Filtration	10 Micron Return	10 Micron Return
	100 Mesh Suction	100 Mesh Suction
System Type	Open Center	Open Center
Reservoir Capacity (Remote)	30 gal. (113 liter)	30 gal. (113 liter)

### RECOMMENDED VEHICLE SPECIFICATIONS

Cab-to-Axle Dimension	84 in. (2.14 m)	84 in. (2.13 m)
Frame Section Modulus	10.1 in 3 (166 cm <sup>3</sup> )	10.1 in 3 (166 cm <sup>3</sup> )
Frame Resisting Bending Moment	363,600 in-lbs. (41,081 N-m)	363,600 in-lbs. (41,081 N-m)
GVWR	17,500 lbs. (7940 kg)	17,500 lbs. (7940 kg)
Approx. Weight for Stability	11,000 lbs. (4990 kg)	11,000 lbs. (4990 kg)

#### Note:

- Specifications may vary without prior notification.
- Actual GVWR and GAWR's should be based on weight and location of the chassis, body, lift, ballast (if required), accessories, and the payload.
- The curb weight of the unit will vary based on the rated platform capacity, mounting configuration, frame stiffness, and stability test requirements.



- Pneumatic Circuit to the Platform
- Personnel Restraint System
- 120 Volt Wiring
- Independent H-Frame or A-Frame Outriggers
- Outrigger Boom Interlock System
- Platform Load Capacity Options
- Unitrol H.R.

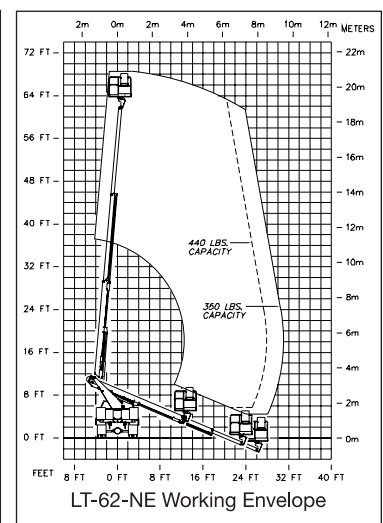
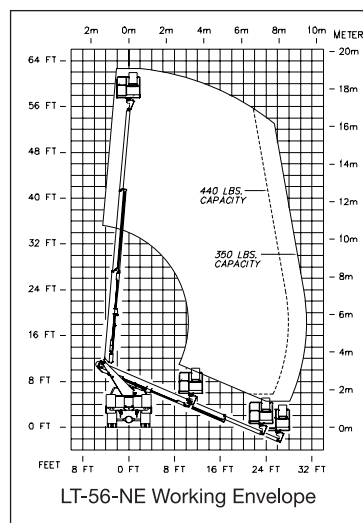

**TIME**  
MANUFACTURING COMPANY  
P.O. Box 20368  
Waco, TX 76702-0368  
254.399.2100  
Fax: 254.399.2651  
1-800-825-1085  
www.timemfg.com

