



# 25 E

Walk behind pick&carry crane  
with 2.500 kg capacity



## FEATURES

**MAX CAPACITY** 2.500 kg  
**MAX BOOM EXTENSION** 2,8 m  
**MAX BOOM ANGLE** 55°  
**MIN BOOM ANGLE** -20°  
**WEIGHT** 2.200 kg  
**CONFORMITY** 2006/42 CE; 2014/30 CE;  
 2014/35 CE; 2000/14 CE; EN 13000

<b>CHASSIS</b>	3 wheels structure made in high quality steel, with internal counterweights
<b>WHEELS</b>	Front: n°2 superelastic wheels 18x7 – R8" Rear: n°1 cushion wheel 300x135
<b>TRACTION</b>	Rear traction with electric motor AC – 3 kW controlled by inverter
<b>HYDRAULIC SYSTEM</b>	Powered by electric motor AC – 4 kW (5 kW with hydraulic winch)
<b>BRAKES</b>	On real wheel by electro brake
<b>STEERING</b>	Rear by steering helm with 180° rotation powered by electric steering motor AC -700W, controlled by inverter. Complete with safety device on backward.
<b>BOOM</b>	Manufactured in high quality steel, composed by three elements: main boom and two telescopic hydraulic sections with two positions tilting head
<b>POWER SUPPLY</b>	Electric
<b>BATTERY</b>	48V - 200 Ah
<b>BOOM'S CONTROL</b>	By wired remote control
<b>DRIVE CONTROL</b>	By steering helm
<b>SAFETY SYSTEM</b>	Electronic load moment indicator (LMI) with display for load, boom's position and boom's angle control
<b>OPTIONALS</b>	Hydraulic winch, manual Jib, radio remote control, non marking wheels, battery watering system, on board battery charger, carry deck, front wheels electro brakes

All specifications are subject to change. Consult Valla for latest specifications

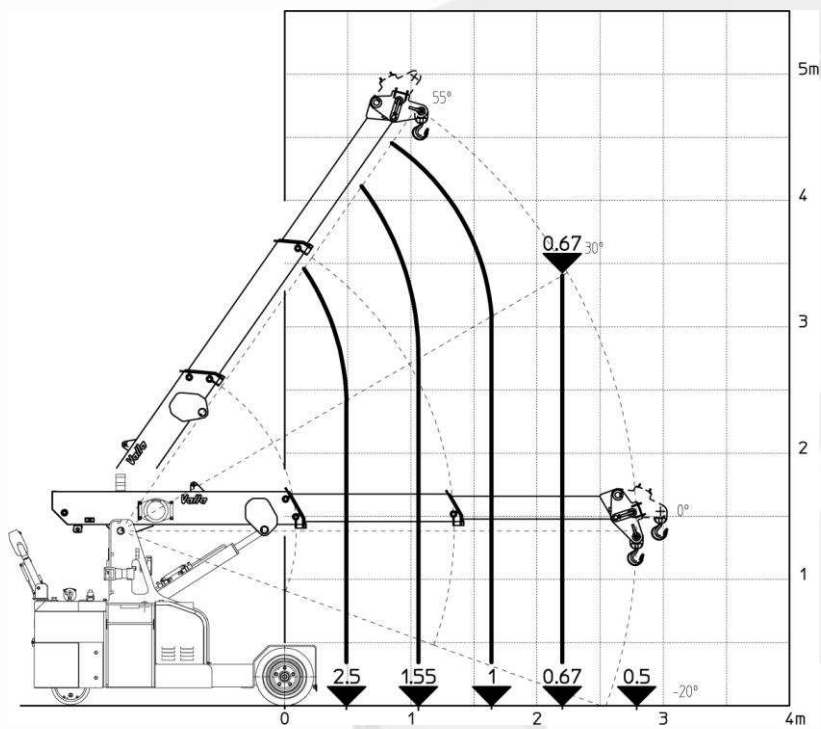

Wired remote control for the aerial part



Fully hydraulic telescopic boom

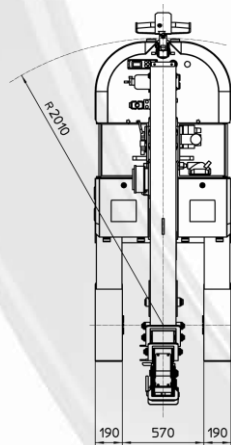
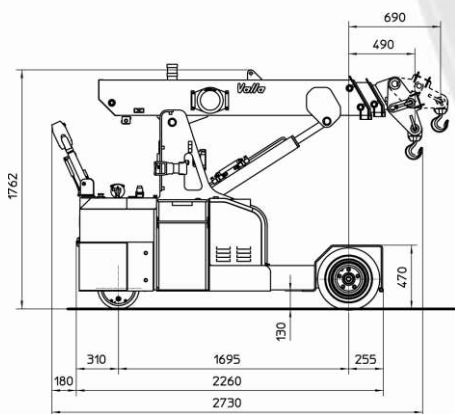

180° steering helm powered by electric motor with 180° rotation for maximum manoeuvrability

**Valla**  
MANITEX

VALLA MANITEX SRL  
Via Leonardo da Vinci 12  
29016 - Cortemaggiore (PC) - ITALY

PHONE: +39 0523 256411  
EMAIL: info@valla.com  
SITE: www.valla.com