

# MOBILOAD 315

## Product Guide



An illustration only

PICK'N'CARRY CRANE

### Features

- CAPACITY - 85% Rating
- PICK 'N' CARRY -15 Tonne at 2.50m radius  
360° SLEW (on Tyres) - 8 Tonnes at 2.5m radius
- BOOM - 4 SECTION – 6.5m to 17.0m
- CARRIER - 4 X 2
- MAXIMUM ROAD SPEED - 35 km/hr

# Superstructure Specification

## **SUPERSTRUCTURE FRAME**

Fabricated from high tensile steel plates and sections.  
Mechanical lock on superstructure.

## **BOOM**

6.5m - 17.0m centres 4-Section Boom comprising:  
6.5m -13.5m 3-Section fully powered, fully synchronized boom plus 3.5m power - positioned Fly (4th) section providing 17.0m extended boom length

**Maximum tip height:** 19.5m

## **BOOM ELEVATION**

Two double acting hydraulic cylinders mounted on large diameter bushes, fitted with combined cartridge type hydraulic lock and counter-balance valve to prevent ram collapse in the event of hydraulic failure.  
Boom Angle: Max 72°, Min -3°

## **SLEW SYSTEM**

Hydraulic motor, driving a pinion through double reduction gear unit. The pinion meshes with internally cut slew ring gear for 360° smooth and precise continuous rotation. Spring applied hydraulically released multi plate brake.

**Slew Speed:** 1.4 rev/min (unladen)

## **HOIST SYSTEM**

Hydraulic motor driving hoist barrel via reduction gear unit, fitted with counterbalance valve for controlled lowering of the load. Spring actuated hydraulically released multi plate brake.

Warning signal from 3rd wrap indicator provided.

**Non spin hoist Rope:** 13mm dia. and length 80m

**Permissible Line Pull:** 30 kN

## **HOOK BLOCK**

16 Tonne capacity: 5 fall hook block

## **COUNTERWEIGHT**

Dual counter weights mounted on rear of carrier frame and on superstructure.

## **LOAD MOMENT INDICATOR**

LMI indicates the crane operating radius, permissible lifting load, actual hook load, length and angle of boom through display panel provided in the cab. Motion cut functions activated through signals from LMI. It cuts – derricking out, telescoping out and hoisting motion when overload condition is reached.

## **HYDRAULIC SYSTEMS**

### **Pump Type:**

Two-section hydraulic vane pump driven through transmission PTO.

### **Control Valve:**

Double acting single spool lever control valve with relief pressure setting, Slew valve bank and tele, derrick and hoist valve bank in operator's cab.

### **Filter:**

Return line filter with mechanical service indicator.

## **HYDRAULIC TANK**

Capacity - 160 L

## **CARRY-DECK**

Max. 2Te load can be placed within deck space for transportation with a speed of 15 kmph (max.).

## **OPTIONAL EQUIPMENT**

Lattice boom extension

- 5.0m lattice extension mounted in line with main boom
- Towing hook, 5Te capacity (front)
- Fire extinguisher
- Man Carrying Basket
- Spare Tyre

# Height of Lift: 6.5m - 17.0m Boom with 5.0m Lattice Extension

## 4 - SECTION BOOM LATTICE – WORKING RANGE DIAGRAM (BOOM DEFLECTION NOT SHOWN)

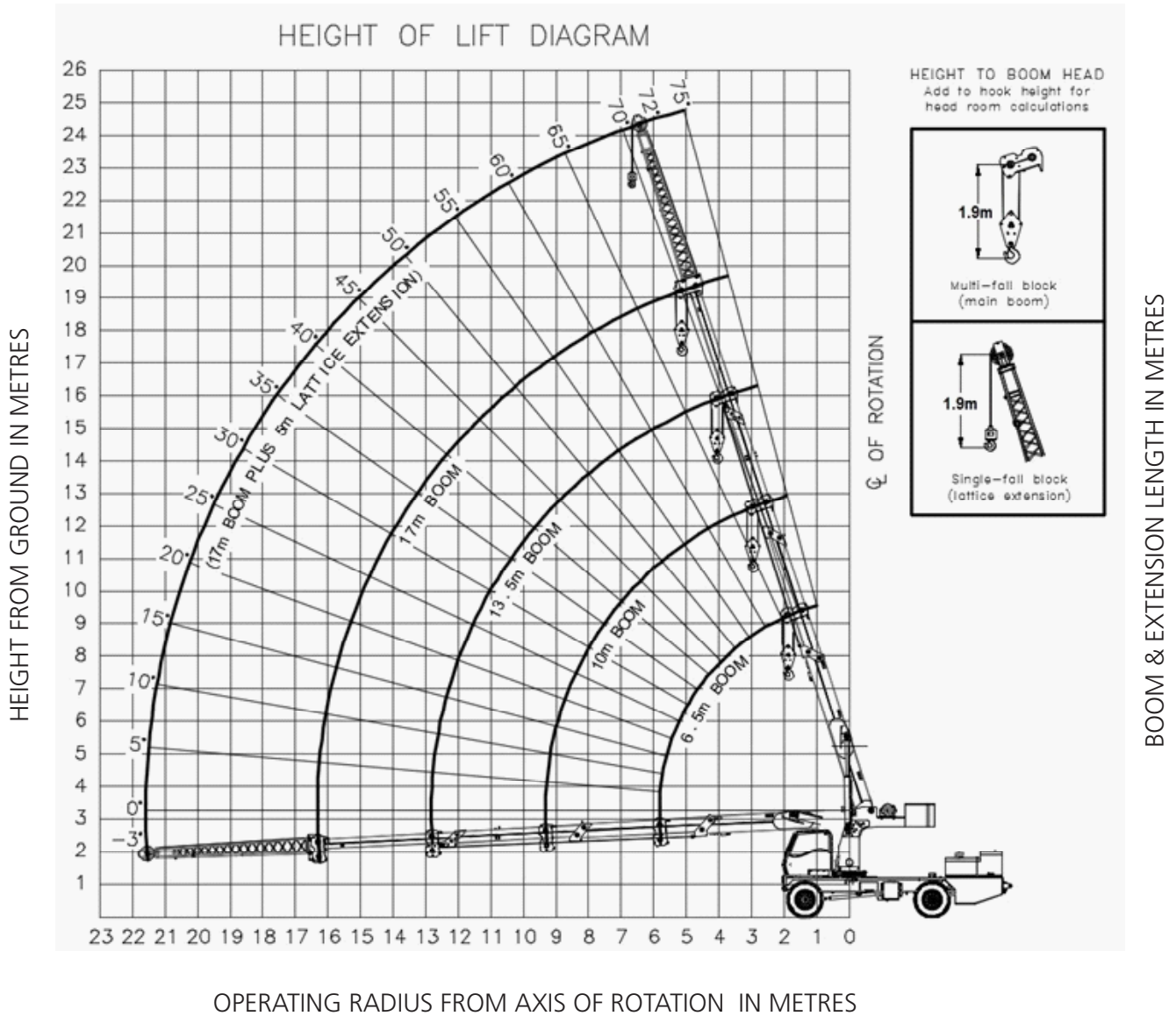

NOTE:  
The above heights of lift and boom angles are based on a straight (unladen) boom and allowance should be made for boom deflections obtained under laden conditions.

### Hookblock Capacities and Weights - Tonnes

No. of Falls	5	4	3	2	1
Permissible Load	15.0	11.0	8.0	5.0	2.5
Weight of Hookblock	0.15	0.15	0.15	0.15	0.075

# Lifting Capacities (Tonne)

**Load Lifting Capacity in Tonne On Tyres (Pr. 115 PSI)  
Pick & Carry over front 85 % Rating@ 5 kmph (U.N.O.)**

Radius (in Meters)	Main Boom Length (in Metres )				
	6.5	6.5 –10.0	10.0 -13.5	13.5 - 17.0	22.0
	Boom Fully retracted	Fly Extension retracted	Fly Extension retracted	Boom Fully Extended	Boom Fully Extended + Lattice
2.50	15.00 *				
2.75	13.00 *				
3.00	11.50	11.00			
3.50	9.30	8.90			
4.00	7.80	7.40	7.40		
5.00	5.90	5.60	5.60		
6.00		4.50	4.50	4.00	
7.00		3.60	3.60	3.30	1.20
8.00			3.00	2.70	1.00
9.00			2.50	2.30	0.90
10.00			2.20	2.00	0.80
11.00			1.90	1.70	0.70
12.00			1.60	1.50	0.60
13.00				1.30	0.55
14.00				1.20	0.50
16.00				0.90	0.40
18.00					0.35

**Note:**

\* Recommended speed 2 kmph

Over front capacities must only be lifted within a maximum slewing angle of 2.1/2° either side of crane centre line.

# Lifting Capacities (Tonne)

## Load Lifting Capacity in Tonne On Tyres (Pr. 115 PSI) Static 360 Degree slew 85 % Rating

Radius (in Meters)	Main Boom Length (in Metres )				
	6.5m	6.5 –10.0m	10.0 -13.5m	13.5 - 17.0m	22.0m
	Boom Fully retracted	Fly Extension retracted	Fly Extension retracted	Boom Fully Extended	Boom Fully Extended + Lattice
2.50	8.00				
2.75	7.00				
3.00	6.30	6.50			
3.50	5.00	5.30			
4.00	4.00	4.00	4.50		
5.00	2.50	3.00	3.00		
6.00		2.00	2.20	2.20	
7.00		1.50	1.60	1.80	1.20
8.00			1.20	1.50	1.00
9.00			0.90	1.10	0.80
10.00			0.60	0.90	0.60
11.00			0.40	0.70	0.50
12.00				0.50	0.40
13.00				0.40	0.35
14.00				0.30	0.30

### Notes for Lifting Capacities

**WARNING: THIS CHART IS ONLY A GUIDE.** The notes below are illustrations only and should not be relied upon to operate the crane. The individual crane's load chart, operating instructions and other instruction plates must be read and understood prior to operating the crane.

1. All rated loads have been tested to meet minimum requirements of IS: 4573-1982 Specification for Power Driven Mobile Crane and do not exceed 85% of the tipping load on rubber as determined by SAE J765 OCT80 Crane Stability Test Code.
2. Capacities above the thick line are based on factors other than stability. Hence crane tipping must not be relied upon as a guide to the capacity limitation.
3. The rated load includes weights of hook block, slings and all similarly used load handling devices. When more than minimum required reeving is used, the additional rope weight shall be considered part of the load. Load ratings are based on freely suspended loads. No attempt shall be made to move a load horizontally on the ground in any direction.

4. Capacities quoted are based on freely suspended loads with the machine standing on a firm, level and uniformly supporting surface and tyres inflated to their correct pressures. It may be necessary to have structural supports under the tyres to spread the load, to a larger bearing surface.
5. For pick and carry operation boom must be centered front of the machine with mechanical slew lock engaged.
6. Do not lower fully extended boom below 30° over side.

**WARNING – Operation of the machine with heavier load than the capacities listed is strictly prohibited. Machine tipping occurs without advance warning.**

# Carrier Specification

## CHASSIS

High-strength steel frame with integrated carry deck.

## OPERATOR'S CAB

Totally enclosed steel construction, with excellent visibility for crane operation through front and overhead screen. Adjustable seat on slides, cab interior light, electric fan, electric horn and lockable hinged door. Ergonomically designed seat and controller layout to provide fatigue free operator comfort.

## CRANE CONTROLS

Lever operating controls for slew, telescoping, hoisting and derricking with independent or simultaneous operation of crane motions.

## TRAVEL CONTROLS

Normal automotive controls including steering wheel, brake and accelerator pedals, gear shift knob mounted on the steering column.

## INSTRUMENTATION

Dash Panel with gauges for engine oil pressure, engine coolant temperature, transmission oil temperature, engine hour-meter, fuel level, air pressure, tachometer, voltmeter and speedometer.

Warning lights for alternator, parking brake, indication and direction indicator.

## ENGINE

Heavy duty water cooled, turbocharged, intercooler 4 cylinder diesel engine of emission compliance to BSIII (CEV)

Power – 74.3 kW @ 2200 RPM

Torque – 390 Nm @ 1400 -1700 RPM

## TRANSMISSION

Power shift TC Transmission with four forward and three reverse speeds with the shifter mounted on steering column.

## FUEL TANK

Capacity - 100 liters

## DRIVE

Two wheel front axle drive (4X2).

## STEERING

Fully independent power steering: Front axle steered through hydraulic power controlled orbitrol steering unit operated by automotive type steering wheel.

Turning Radius: 8.5m

## AXLES

**Front:** Drive and steer planetary axle with differential and planetary hub reduction solidly mounted to the chassis frame.

**Rear:** Non steer non-drive axle, pivot mounted at centre of the chassis frame. Oscillation lock hydraulically operated during slew.

## BRAKES

**Service Brake:** Foot operated dual line compressed air over hydraulic brake on front axle and air brake on rear axle.

**Parking Brake:** Spring actuated, air released fail-safe brake on rear wheels.

## TYRES

11.00 X 20 –16 PR tyres. 4nos. on the front axle and 4 nos. on the rear axle.

## ELECTRICAL SYSTEM

12 V starting and lighting equipment.

## SPEEDS

35 kmph (unladen); 15 kmph (carry deck speed)

5 kmph (pick and carry)

## GRADEABILITY

25 % (Un-laden)

## GROSS VEHICLE WEIGHT (GVW)

GVW : 16.65 Tonne

# G.A Drawing

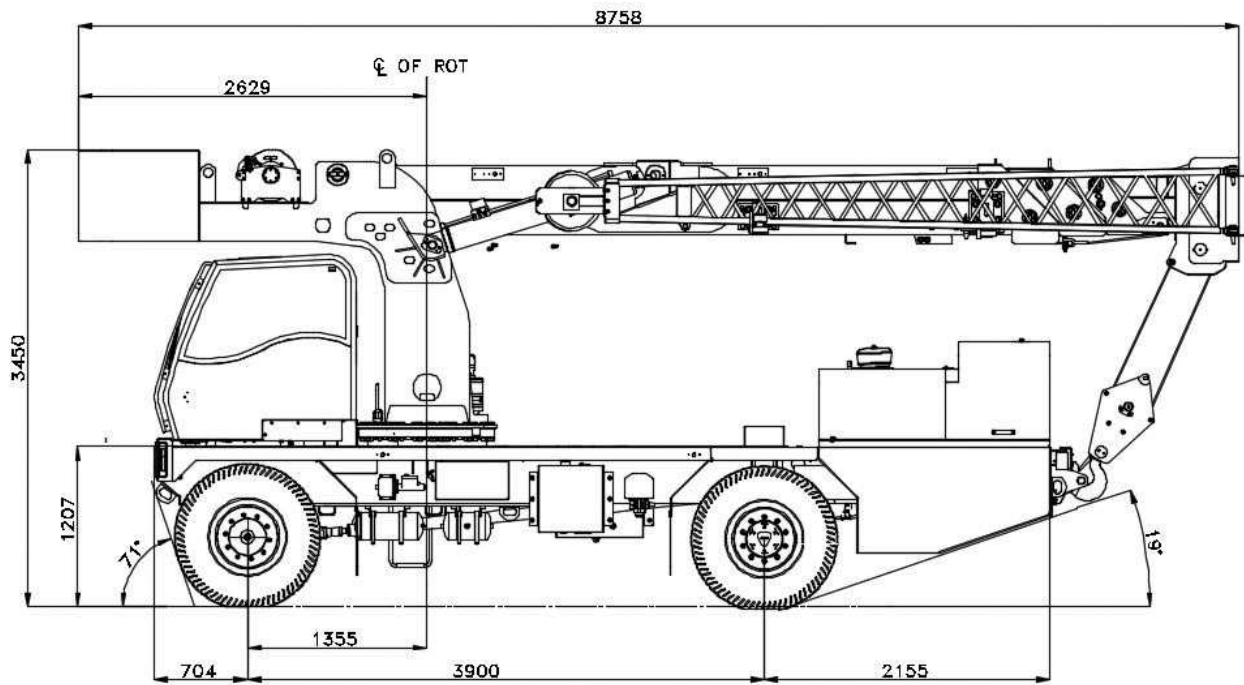
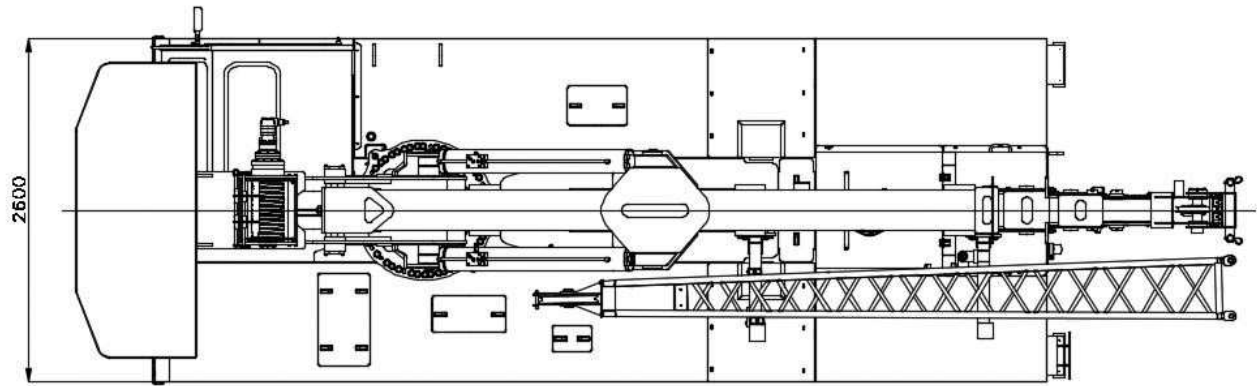

Dimensions in mm

Constant improvement and engineering progress make it necessary that we reserve the right to make specification, equipment and price changes without notice. Illustration shown may include optional equipment, accessories and may not include all standard equipment.

MOBILOAD 315

Technical Specification TIL/MOBILOAD 315/1117

Courtesy of CraneMarket.com



## TIL Limited

CIN: L74999WB1974PLC041725

### Registered & Corporate Office:

1, Taratolla Road, Garden Reach, Kolkata - 700024  
Phone: + 91 33 2469 3732-6 / 6497 | 6633 2000 / 2845  
Fax: + 91 33 2469 2143 / 3731  
Email: Mhg.Er@tilindia.com | mktg-til@tilindia.com



### CHENNAI

TIL Limited  
Jhaver Plaza, 7th Floor 1-A  
Nungambakkam High Road  
Chennai 600 034, Tamil Nadu  
Phone: +91 44 6670 3000 / 3010  
Fax: +91 44 2827 9681  
Email: chennai.til@tilindia.com

### DELHI NCR

Plot 11, Site No.IV  
Sahibabad Industrial Area  
Ghaziabad 201 010 U.P.  
Phone: +91 120 277 8735 / 8736 / 7468  
Fax: +91 120 277 7467  
Email: MHGMarketing.Sahibabad@tilindia.com | mhgcs.Sahibabad@tilindia.com

### DELHI

TIL Limited  
302 Ansal Bhawan  
16, Kasturba Gandhi Marg, New Delhi 110 001  
Phone: +91 11 2331 1607 / 8046 / 9248 | 2335 0250 / 0255  
Fax: +91 11 2331 3263  
Email: til.delhi@tilindia.com

### KAMARHATTY

TIL Limited  
517, Barrackpore Trunk Road  
Kolkata 700 058  
Phone: +91 33 2553 1352 / 1882 | 6633 4000  
Fax: +91 33 2553 2546 / 5971  
Email: MktDept.KMT@tilindia.com | til.kmt@tilindia.com

### KHARAGPUR

TIL Limited  
Vill. & P.O. Changual, Kharagpur  
Dist: Paschim Medinipur 721 301, West Bengal  
Phone: +91 32 2266 1101

### MUMBAI

TIL Limited  
A - 606, A Wing, 6th Floor,  
215 Atrium, Andheri - Kurla Road,  
Andheri (East), Mumbai 400059, Maharashtra  
Phone: + 91 22 4969 1169  
Mobile: +91 8850971609  
Email: Mumbai.TIL@tilindia.com | Mumbai.Custsupp@tilindia.com

**TIL has a pan-India network of offices with service engineers located in the close proximity of jobsites.**

Toll Free No: **1800 266 1535**

[www.tilindia.in](http://www.tilindia.in)

Technical Specification TIL/MOBILOAD 315/1117