

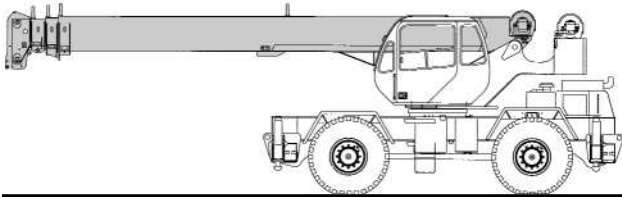

TEREX RT 200/RT200XL SERIES

rough terrain cranes
specifications



STANDARD BOOM EQUIPMENT

BOOM

30-94 ft. (9.23-28.78 m), four section full power boom. Telescoping is mechanically synchronized with single lever control. The synchronization system consists of a single telescope cylinder and high strength leaf chains to extend and retract the third section and tip section. Boom is high strength four plate design, welded inside and out, with anti-friction slide pads. Boom side plates are made with stamped impressions to reduce weight and increase strength. A single boom hoist cylinder provides for boom elevation of -4 to 76 degrees. All

cylinders are equipped with integral hold valves. Maximum tip height is 99 ft. (30.17 m).

BOOM HEAD

Welded to outer section of boom. Four or five metallic load sheaves and two idler sheaves mounted on heavy duty, anti-friction bearings. Quick reeving boom head. Provisions made for side-stow jib mounting.

OPTIONAL BOOM EQUIPMENT

MAIN BOOM

30-72 ft. (9.23-22.19 m), three section full power boom
OR 30-100 ft (9.23-30.61 m), four section full power XL Series boom.

Telescoping is mechanically synchronized with single lever control. The synchronization system consists of a single telescope cylinder and high strength leaf chains to extend and retract the tip section. Either boom is high strength four plate design, welded inside and out, with anti-friction slide pads. Boom side plates are made with stamped impressions to reduce weight and increase strength. A single boom hoist cylinder provides for boom elevation of -4 to 76 degrees. All cylinders are equipped with integral hold valves. Maximum tip height with 72 ft. (22.19 m) boom option is 79 ft. (24.23 m). Maximum tip height with 100 ft. (30.61 m) XL Series boom option is 107 ft. (32.76 m).

JIBS

26 ft. (7.92m) side stow swing-on one-piece lattice type jib. Single metallic sheave mounted on anti-friction bearing. Jib is offsettable at 0°, 15°, or 30°. With 100 ft. (30.61 m) XL Series boom, maximum tip height is 130 ft. (39.62 m).

26-43 ft. (7.92-13.11 m) side-stow swing-on lattice type jib. Single sheave mounted on anti-friction bearing. Jib is extendible to 43 ft. (13.11 m) by means of a 17 ft. (5.18 m) manual pull-out tip section, roller supported for ease of extension. Jib is offsettable at 0°, 15°, or 30°. With 100 ft. (30.61 m) XL Series boom, maximum tip height is 147 ft. (44.80 m).

AUXILIARY BOOM HEAD

Removable auxiliary boom head has single metallic sheave mounted on anti-friction bearing. Removable pin-type rope guard for quick reeving. Installs on main boom peak only. Removal is not required for jib use.

HOOK BLOCK

Two, three, or four metallic sheaves on anti-friction bearings with hook and hook latch. Quick reeving design does not require removal of wedge and socket from rope.

HOOK & BALL

7.0 ton (6.3 mt) top swivel ball with hook and hook latch.

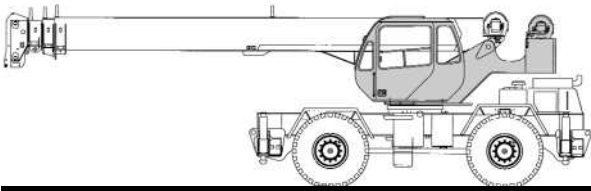

STANDARD UPPERSTRUCTURE EQUIPMENT

UPPERSTRUCTURE FRAME

All welded one-piece structure fabricated with high tensile strength alloy steel. Counterweight is bolted to frame.

TURNTABLE CONNECTION

Swing bearing is a single row, ball type, with external teeth. The swing bearing is bolted to the revolving upperstructure and welded to the carrier frame.

SWING

A hydraulic motor drives a double planetary reduction gear for precise and smooth swing function. Maximum swing speed (no load) is 3.0 rpm.

SWING BRAKE

Heavy duty multiple disc swing brake is mechanically actuated from operator's cab by foot pedal. Brake may be locked on or used as a momentary brake. A separate 360° mechanical house lock is also provided.

RATED CAPACITY INDICATOR

Rated Capacity Indicator with visual and audible warning system and automatic function disconnects. Second generation pictographic display includes: boom radius, boom angle, boom length, allowable load, actual load, and percentage of allowable load registered by bar graph. Operator settable alarms provided for swing angle, boom length, boom angle, tip height, and work area exclusion zone. Anti-two block system includes audio/visual warning and automatic function disconnects.

OPERATOR'S CAB

Environmental cab with all steel construction, optimized visibility, tinted safety glass throughout, and rubber floor matting is mounted on vibration absorbing pads. The cab has a sliding door on the left side, framed sliding window on the right side, hinged tinted all glass skylight and removable front windshield to provide optimized visibility of the load open or closed. Acoustical foam padding insulates against sound and weather.

The deluxe six-way adjustable operator's seat is equipped with a mechanical suspension and includes head and arm rests.

CONTROLS

All control levers and pedals are positioned for efficient operation. Hand operated control levers include swing, telescope, boom hoist, winch(s), shift, vernier adjustable hand throttle and 360° house lock. Switches include ignition, engine stop, two speed winch(s), lights, horn, windshield wipers, defroster, steering mode, parking brake, and outrigger controls. Foot control pedals include swing brake, boom raise, boom lower, service brakes and accelerator.

INSTRUMENTATION AND ACCESSORIES

In-cab gauges include air pressure, bubble level, engine oil pressure, fuel, engine temperature, voltmeter, transmission temperature, and transmission oil pressure. Indicators include low air, high water temperature/low oil pressure/high transmission temperature audio/visual warning, low coolant audio/visual warning, hoist drum rotation indicator(s), and Rated Capacity Indicator. Accessories include fire extinguisher; light package including headlights, tail lights, dome light, brake lights, directional signals, four-way hazard flashers, dome light, and back-up lights with audio pulsating back-up alarm; windshield washer/wiper and skylight wiper, R.H. and L.H. rear view mirrors; dash lights; and seat belt. Circuit breakers protect electrical circuits.

HYDRAULIC CONTROL VALVES

Valves are mounted on the upperstructure and are easily accessible. Valves are mechanically operated and include one four spool valve for boom elevation, telescope, main winch boost, and main winch; one single spool valve for swing. High pressure regeneration feature provides 2-speed boom extension. Quick disconnects are provided for ease of installation of pressure check gauges.

OPTIONAL EQUIPMENT

Auxiliary Winch • Heater/Defroster • Air Conditioner • Work Lights • Revolving Amber Light • Independent Rear Wheel Steering • Roof Mounted Spotlight

STANDARD CARRIER EQUIPMENT

CARRIER CHASSIS

High strength chassis with four-wheel drive and four-wheel steer (4x4x4). Has box beam type construction with reinforcing cross members, a precision machined turntable mounting plate and integrally welded outrigger boxes. Decking has skid-resistant surfaces, including tool storage compartment, and access steps and handles left and right side and front and rear corners.

AXLES AND SUSPENSION

Rear axle is a planetary drive/steer type with total 10 in. (0.25m) of oscillation. Automatic oscillation lockouts engage when the superstructure is swung 10° in either direction. Front axle is planetary drive/steer type, rigid mounted to the frame for increased stability.

WHEELS & TIRES

Disc type wheels with full tapered bead seat rim. 134 in. (3.40 m) wheelbase.

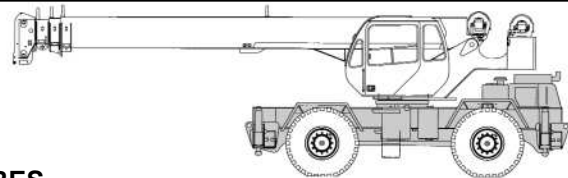

TIRES

Standard: 20.5 x 25, 24 P.R.
Optional: 16.00 x 25, 28 P.R.

SERVICE BRAKES

Air over hydraulic drum type brakes on all four wheels: 17" x 4" (43.18 x 10.2 cm) drum brakes.

PARKING BRAKE

Transmission mounted spring-set, air released external caliper disk type emergency/parking brake.

STEERING

Hydraulic four-wheel power steering for two-wheel, four-wheel, or crab steer is easily controlled by steering wheel. A rear axle centering light is provided.

STANDARD CARRIER EQUIPMENT (continued)

Turning radius to center of outside tire.

| | | |
|-------------|--------------------|---------------------|
| | (16.00 x 25) | (20.5 x 25) |
| Two-wheel: | 34' 8.81" (10.50m) | 34' 10.38" (10.63m) |
| Four-wheel: | 19' 3.44" (5.88m) | 19' 5" (5.92m) |

TRANSMISSION

Range-shift type power-shift transmission with integral torque converter has neutral safety start, 6 speeds forward, and 6 speeds reverse. Automatic pulsating back-up alarm.

MULTI-POSITION OUT & DOWN OUTRIGGERS

Fully independent hydraulic outriggers may be utilized fully extended, in their 1/2 extended position, or fully retracted. Easily

HYDRAULIC SYSTEM

HYDRAULIC PUMPS

Three gear type pumps, one single and two in tandem, driven off the transmission. Combined system capability is 113 gpm (427.7 lpm). Includes manual pump disconnect.

Main and Auxiliary Winch Pump

53 gpm (200.7 lpm) @ 3,500 psi (246.1 kg/cm²)

Boom Hoist, Telescope Pump

39 gpm (147.6 lpm) @ 3,500 psi (246.1 kg/cm²)

Power Steering, Outrigger and Swing Pump

21 gpm (79.5 lpm) @ 2,500 psi (175 kg/cm²). Always live even when pump disconnect is actuated.

MAIN WINCH SPECIFICATIONS

Hydraulic winch with bent axis piston motor and planetary reduction provides 2-speed operation with equal speeds for power up and down. Winch is equipped with an integral automatic brake, a grooved drum with tapered flanges for improved rope spooling, a spring loaded cable roller and an electronic drum rotation indicator.

PERFORMANCE

Max. line speed (no load)

| | LO-RANGE | HI-RANGE |
|-------------|----------------------|-----------------------|
| First layer | 205 fpm (62.5 m/min) | 329 fpm (100.3 m/min) |
| Fifth layer | 297 fpm (90.5 m/min) | 475 fpm (144.8 m/min) |

| | | |
|----------------------------|----------------------|---------------------|
| Max. line pull-first layer | 12,512 lbs (5675 kg) | 7,298 lbs (3310 kg) |
| Max. line pull-fifth layer | 8,662 lbs (3929 kg) | 5,052 lbs (2292 kg) |
| Permissible line pull | 9,000 lbs (4082 kg) | |

DRUM DIMENSIONS

10.62 in (270 mm) drum diameter
 17.53 in (445 mm) length
 18.25 in (464 mm) flange dia.
 Cable: 5/8 in. x 450 ft (16 mm x 137.2 m)
 Cable type: 5/8 in. (16mm) 6x19 IWRC IPS
 right regular lay, preformed
 Min. breaking strength 17.9 tons (16.2 mt).

DRUM CAPACITY

Max. Storage: 598 ft (182.3 m)
 6th layer not a working layer
 Max. Useable: 479 ft (146.0 m)*

* Based on min. flange height above top layer to comply with ANSI B30.5

removable steel floats, each with an area of 254 in² (1639 cm²), stow on the carrier frame. Complete controls and sight leveling bubble are located in the operators' cab.

OPTIONAL EQUIPMENT

Cold Weather Starting Aid • Immersion Heater • Pintle Hook
 • Clearance Lights • Front Mounted Winch – 20,000 lbs. (9072 kg) • Independent Rear or Four Mode Rear Wheel Steer

FILTRATION

Full flow oil filtration system with bypass protection includes a removable 60 mesh (250 micron) suction screen-type filter and 5 micron replaceable return line filter.

HYDRAULIC RESERVOIR

All steel, welded construction with internal baffles and diffuser. Provides easy access to filters and is equipped with an external sight level gauge. The hydraulic tank is pressurized to aid in keeping out contaminants and in reducing potential pump cavitation. Capacity is 94 gal (355 liters). Swing-away hydraulic oil cooler is standard.

OPTIONAL AUXILIARY WINCH

Hydraulic winch with bent axis piston motor, power up and down, equal speed, planetary reduction with integral automatic brake, cable roller, and rotation indicator.

PERFORMANCE

(Same as main winch)

DRUM DIMENSIONS AND CAPACITY

(Same as main winch)

DRUM CAPACITY

(Same as main winch)

OPTIONAL HOIST LINE – MAIN WINCH AND OPTIONAL AUXILIARY WINCH –

5/8 in. (16 mm) rotation resistant compacted strand 18x19 or 19x19.
 Min. breaking strength 22.6 tons (20.6 mt).

PERFORMANCE (Standard Engine)

| Transmission Range | Gear | Forward Drive | Maximum Speed | Maximum Tractive Effort | Gradeability @ Stall |
|--------------------|------|---------------|---------------|-------------------------|----------------------|
| Low | 1 | 4-wheel | 2.3 mph | 37,856 lbs | 112.34% |
| | | | 3.7 km/h | 17 171 kg | |
| | | | 4.4 mph | 19,254 lbs | 39.84% |
| High | 1 | 4-wheel | 7.1 km/h | 8734 kg | |
| | | | 12.4 mph | 6,431 lbs | 11.10% |
| | | | 20.0 km/h | 2917 kg | |
| High | 2 | 2-wheel | 5.0 mph | 16,893 lbs | 34.04% |
| | | | 8.0 km/h | 7663 kg | |
| | | | 9.5 mph | 8,589 lbs | 15.59% |
| High | 3 | 2-wheel | 15.3 km/h | 3896 kg | |
| | | | 24.5 mph | 2,849 lbs | 3.77% |
| | | | 39.4 km/h | 1292 kg | |

ENGINE SPECIFICATIONS

| Make and Model | Standard | Optional |
|-----------------------|--------------------------------|--------------------------------|
| | Cummins 6BTA5.9 | Caterpillar 3116 DIT |
| Type | 6 cylinder | 6 cylinder |
| Bore and Stroke | 4.02 x 4.72 in (102 x 120 mm) | 4.12 x 5.0 in (105 x 127 mm) |
| Displacement | 359 cu in (5.9 l) | 402 cu in (6.6 l) |
| Max. Gross Horsepower | 130 hp (97 kw) @ 2500 rpm | 140 hp (105 kw) @ 2400 rpm |
| Max. Gross Torque | 384 lb•ft (521 N•m) @ 1200 rpm | 426 lb•ft (578 N•m) @ 1450 rpm |
| Aspiration | turbocharged | turbocharged |
| Air Filter | dry type | dry type |
| Electrical System | 12 volt | 12 volt |
| Alternator | 102 amp | 115 amp |
| Battery | (2) 12V-1600 C.C.A. | (2) 12V-1600 C.C.A. |
| Fuel Capacity | 50 gal (189 l) | 50 gal (189 l) |

All performance data is based on a gross vehicle weight of 52,000 lbs (23 583 kg), 16:00 x 25 tires, 4 x 4 drive. Performance may vary due to engine performance. Gradeability data is theoretical and is limited by tire slip, stability, or engine oil pan design.

GENERAL DIMENSIONS

NOTES:

- Dimensions given assume the boom is fully retracted in travel position and 16:00 x 25 tires. 20.5 tires reduce heights 1.0 (25mm).
- Minimum ground clearance under transmission – 20.62" (0.52m)
 axle bowls – 19.12" (0.49m)
 tie rods – 20.38" (0.52m)

- Track width: 6' 7.50" (2.02m) 16:00 x 25 tires
 6' 10.5" (2.10m) 20.5 x 25 tires

- Width of carrier:
 8'0" (2.44m) 16:00 x 25 tires
 8'8" (2.64m) 20.5 x 25 tires

| Tire to frame angle | 16:00 tires | 20.5 tires |
|---------------------|-------------|------------|
| Approach angle: | 25.1° | 24.1° |
| Departure angle: | 23.1° | 22.2° |

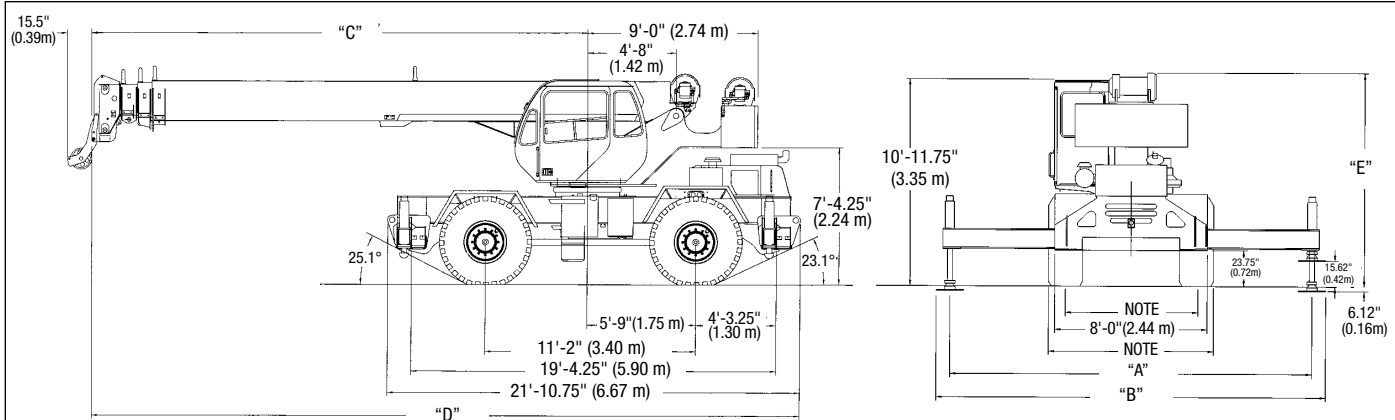

| | "A" | "B" | Boom Length | "C" | "D" | "E" |
|----------------------------|-----------------|-------------------|--------------------|-----------------|-----------------|-------------------|
| Fully extended outriggers | 19'-0" (5.79m) | 20'-6" (6.25m) | 32' (9.75m) Boom | 15'-10" (4.83m) | 27'-1" (8.25m) | 12'-9.38" (3.90m) |
| Pinned outriggers | 13'-2" (4.01m) | 14'-8" (4.47m) | 72' (22.19m) Boom | 26'-4" (8.03m) | 37'-7" (11.46m) | 11'-7.5" (3.54m) |
| Fully retracted outriggers | 7'-4.5" (2.25m) | 8'-10.5" (2.71 m) | 94' (28.78m) Boom | 26'-4" (8.03m) | 37'-7" (11.46m) | 11'-7.5" (3.54m) |
| | | | 100' (30.61m) Boom | 28'-4" (8.64m) | 39'-7" (12.06m) | 11'-7.5" (3.54m) |

| WEIGHTS & AXLE LOADS | GROSS WEIGHT LBS. | UPPER FACING FRONT | | GROSS WEIGHT KG. | UPPER FACING FRONT | |
|---|-------------------|--------------------|---------|------------------|--------------------|--------|
| | | FRONT | REAR | | FRONT | REAR |
| Basic Crane with 10,000 lb. (4536 kg) Counterweight | 55,930 | 28,972 | 26,958 | 25,369 | 13,141 | 12,228 |
| Add Options: | | | | | | |
| 26' (7.92 m) Swing-on Jib (Stowed) | + 1,100 | + 2,000 | - 900 | + 499 | + 907 | - 408 |
| 26'-43' (7.92-13.11 m) Swing-on Jib (Stowed) | + 1,500 | + 2,600 | - 1,100 | + 680 | + 1179 | - 499 |
| Auxiliary Boom Head | + 100 | + 300 | - 200 | + 45 | + 136 | - 91 |
| Auxiliary Winch with Wire Rope, Controls, Etc. | + 115 | - 25 | + 140 | + 52 | - 11 | + 63 |
| 30 ton (27.2 mt) 4 Sheave Hook Block | + 655 | + 1,071 | - 416 | + 297 | + 486 | - 189 |
| 30 ton (27.2 mt) 3 Sheave Hook Block | + 670 | + 1,099 | - 429 | + 304 | + 498 | - 194 |
| 25 ton (22.6 mt) 2 Sheave Hook Block | + 682 | + 1,117 | - 435 | + 309 | + 507 | - 198 |
| 6.25 ton (5.7 mt) Hook and Ball (in tool box) | + 240 | + 290 | - 50 | + 109 | + 130 | - 21 |
| Pintle Hook: Front | + 45 | + 60 | - 15 | + 20 | + 27 | - 7 |
| Rear | + 45 | - 25 | + 70 | + 20 | - 11 | + 31 |
| Substitute: | | | | | | |
| 72' (22.19 m) Full Power 3-section Boom | - 3,190 | - 4,335 | + 1,145 | - 1,445 | - 1,965 | + 520 |
| 100' (30.61 m) Full Power 4-Section Boom | + 533 | + 1,986 | - 1,453 | + 242 | + 901 | - 659 |
| 16.00 x 25 Tires | - 360 | - 180 | - 180 | - 164 | - 82 | - 82 |

NOTE: Weights are for factory supplied equipment and subject to 2% variation due to manufacturing tolerances.

WE RESERVE THE RIGHT TO AMEND THESE SPECIFICATIONS AT ANY TIME WITHOUT NOTICE. THE ONLY WARRANTY APPLICABLE IS OUR STANDARD WRITTEN WARRANTY APPLICABLE TO THE PARTICULAR PRODUCT AND SALE. WE MAKE NO OTHER WARRANTY, EXPRESSED OR IMPLIED.



106 12th Street S.E.
 Waverly, IA 50677-9466 USA
 (319) 352-3920 • FAX: (319) 352-5727
 E-mail: inquire@terexwaverly.com

