

SPECIFICATIONS

RT 175

75 Ton (68 tonne) Capacity
Series Rough Terrain Crane

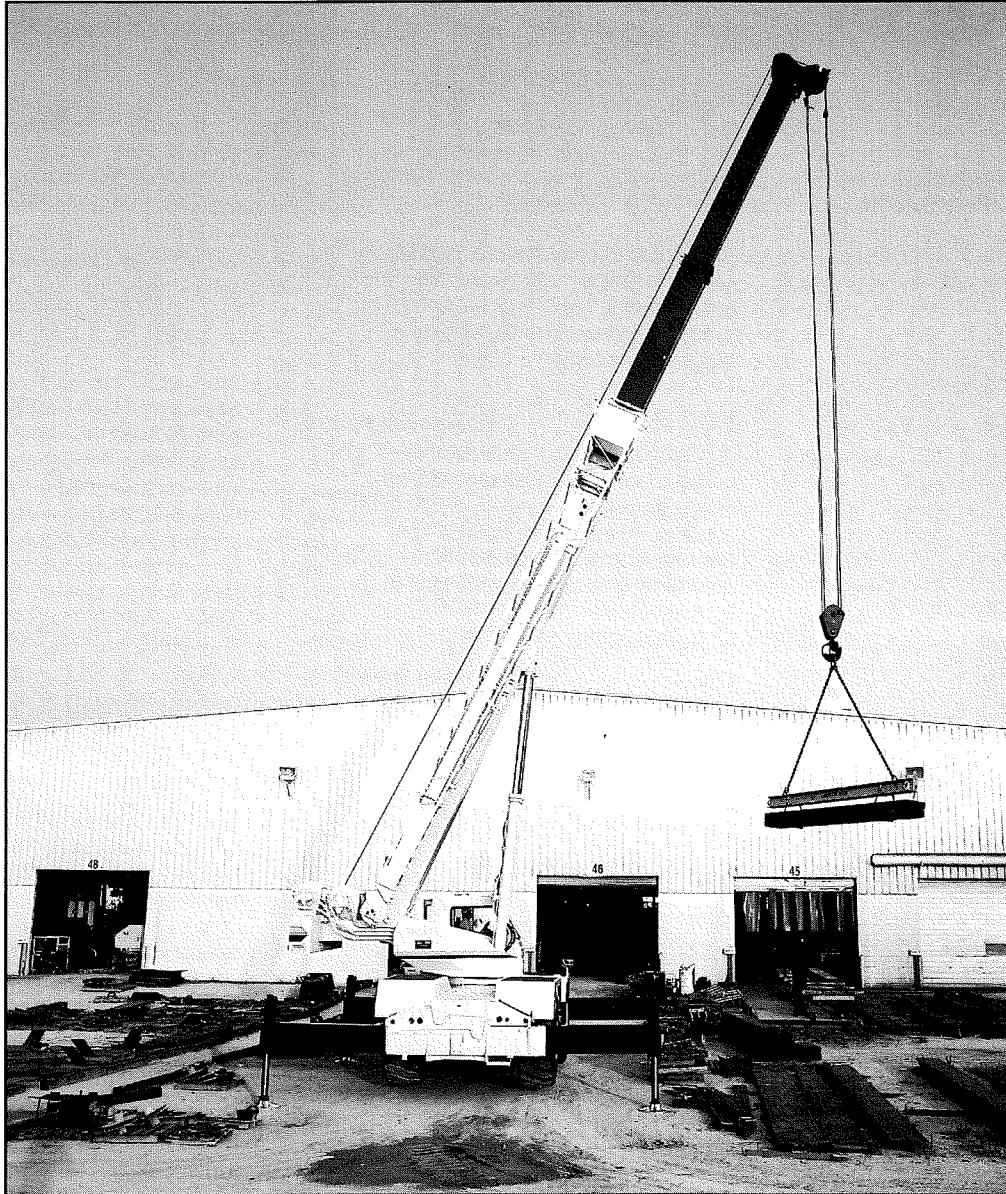

 **TEREX CRANES, INC.**

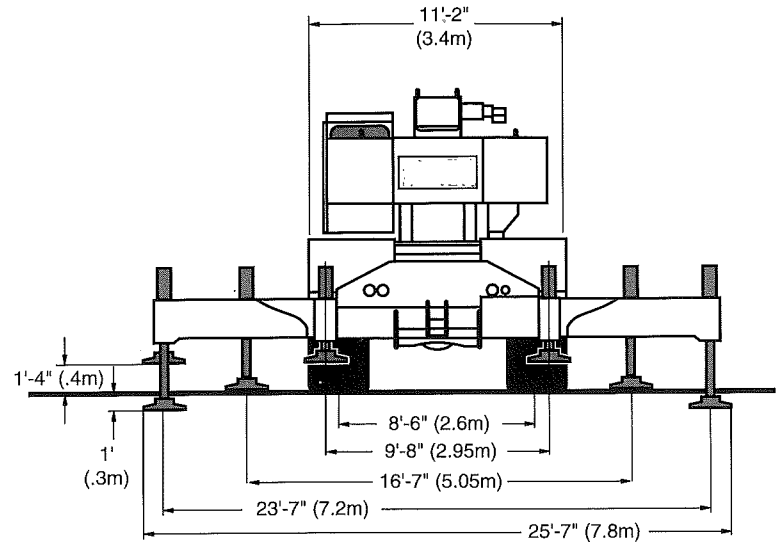

RT 175 FEATURES

- **126 ft. (38.4 m) Full Power Boom:** Welded inside and out with no derate for duty cycle work.
- **Lattice Extensions:** Swingaway with telescoping stinger for a maximum tip height of 193 ft. (58.8 m).
- **Three Position Outrigger Rating.**
- **Strong Winches:** Bent axis motors give you smooth operation and a maximum line pull of 22,410 lbs. (10165 kg).
- **Four Steering Modes:** Front-wheel, 4-wheel coordinated crab or crab, independent & rear, all controlled by the steering wheel.
- **Pride Plus Warranty:** The most comprehensive warranty in the business. Covers the entire crane for 12 months or 2,000 hours of operation. Plus, major weldment structures are covered for 5 years or 10,000 hours.

This crane meets the requirements of ASME B30.5. The machine structure has been tested per SAE J1063. The machine stability has been tested per SAE J765.

BOOM

40 ft. to 126 ft. (12.2 m to 38.4 m), full power, four-section telescopic boom. Boom point has five non-metallic main sheaves and two non-metallic idler sheaves. Metallic sheaves are available. A mechanical boom angle indicator is provided.

Boom Telescope:

One single stage double acting cylinder and chain crowd mechanism. Mechanically synchronized boom.

Boom Hoist:

Two double-acting cylinders provide elevation from -2 degrees to 78 degrees.

BOOM OPTIONS

Lattice Extension:

Telescopic Lattice Extension:

Swingaway, 38 ft. to 60 ft. (12.2 m to 18.3 m), self-storing on the base section of main boom.

Offset Mechanism:

Pivoting links which allow lattice extensions to offset 17 or 30 degrees from the main boom.

Auxiliary Boom Point:

Mounted at boom point with single sheave.

COUNTERWEIGHT

15,200 lbs. (6895 kg) bolt-on type.

CAB

All-weather environmental cab of steel has locking door and opening ceiling, side, and rear windows with tinted safety glass throughout. Operator's cloth-covered seat is fully adjustable and has shock-absorbing suspension and seat belt. Steering column tilts and telescopes for comfort. Cab is cushion-mounted for vibration dampening and noise reduction. Contains all roading and crane function controls including armrest-mounted joystick or twin lever controls for swing, auxiliary winch, main winch, and boom hoist. Foot pedals for swing brake, boom telescope, service brakes and engine throttle.

Front console includes gauges for engine water temperature, engine oil pressure, hydraulic oil temperature, transmission oil temperature, air pressure and fuel. Also includes hourmeter, speedometer, tachometer, voltmeter, winch high speed indicator, rear steer centering light, engine condition warning system, anti-two block device and electronic LMI. Additional cab equipment includes windshield wiper and washer, defroster fan, interior cab light, fire extinguisher, machine level gauge, electric horn and hand throttle.

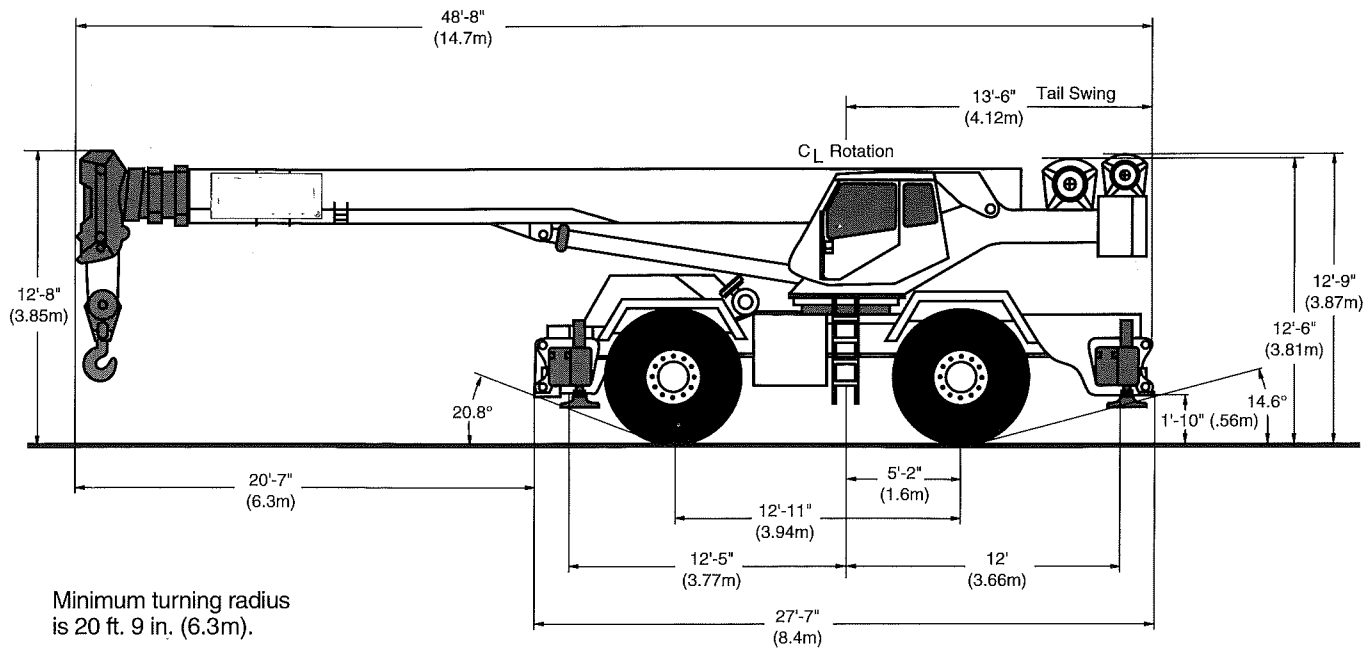

WINCH

2080:

Two-speed with bent axis piston motor, planetary gearing with equal speed power raising and lowering, and infinitely variable speed control. Has automatic multi-disc brake and drum turn indicator.

Drum Capacity:

780 ft. (238 m) of 3/4 in. (19 mm) wire rope.

Wire Rope:

550 ft. (167 m) of 3/4 in. (19 mm) diameter, 6x37 EIPS with 7x7 IWRC.

Line Pull (Max):

22,410 lbs. (10165 kg) first layer, low speed. 16,845 lbs. (7640 kg) fifth layer.

Line Pull (Max available for starting loads in mid-air):

15,000 lbs. (6802 kg) fifth layer.

Line Speed (Max):

441 fpm (134 mpm) fifth layer, high speed.

HOISTING OPTIONS

Auxiliary Winch:

1580 two-speed with bent axis piston motor, planetary gearing with equal speed power raising and lowering, and infinitely variable speed control. Has automatic multi-disc brake and drum turn indicator. Wire rope is optional.

Drum Capacity:

554 ft. (168 m) of 3/4 in. (19 mm) wire rope.

Line Pull (Max):

18,282 lbs (8291 kg) first layer, low speed. 13,223 lbs (5997 kg) fifth layer. Maximum available line for starting loads in mid-air 11,000 lbs (4991 kg) fifth layer.

Line Speed (Max):

631 fpm (192 mpm) fifth layer, high speed.

Auxiliary Winch:

Same as main winch. Wire rope is optional.

Auxiliary Winch Wire Rope:

550 ft. (168 m) of 3/4 in. (19 mm) diameter, 6x37 EIPS with 7x7 IWRC or rotation resistant 8x19 EIPS with 7x7 IWRC.

Cable Spooling Device:

For main or auxiliary winches.

Hook Blocks:

75 ton (68 tonne) with five sheaves, or 20 ton (18 tonne) with one sheave.

Headache Ball:

8.5 ton (7.7 tonne) weighted hook.

SWING UNIT

360 degree continuous rotation to 2.1 rpm with disc brake, integral with swing reducer.

House Lock:

Manually engaged 360 degree house lock.

HYDRAULIC SYSTEM

System uses two tandem gear-type pumps with a total flow of 142 gpm (536 lpm). Filtration is by two 7-micron return line filters externally mounted to the reservoir and one 20-micron pressure line filter. An oil cooler and manual disconnect are standard.

Oil Reservoir:

177 gallon (670 liter) capacity.

CARRIER

Outriggers:

Independent, out and down type with control from the cab. Outriggers may be set in three positions with full extensions to 23 ft. 7 in. (7.2m). Front to rear spread is 24 ft. 5 in. (7.4 m).

Outrigger Floats:

21 in. (533 mm) square with storage on carrier.

Front Axle:

Planetary drive/steer, rigid mounted.

Rear Axle:

Planetary drive/steer, mounted on oscillating cradle with hydraulic lockout cylinders. Oscillation is $\frac{3}{8}$ 5.2 in. (132 mm). Oscillation lockout override control. Drive disconnect for two-wheel drive operation.

Service Brakes:

Dual circuit, air over hydraulic drum brakes at each wheel.

Parking Brakes:

Drum brake on rear axle input shaft.

Steering:

Hydrostatic power steering, front and rear axles. Control modes for front only, four-wheel cramp and crab steering, all controlled by the steering wheel. Switch for independent rear steer. Minimum turning radius is 20 ft. 9 in. (6.3 m).

Tires:

29.5x25-28PR tubeless with rock tread (E-3).

Tire Options:

Spare tire with rim. Tire inflation kit.

(continued on back)

ENGINE

Cummins 6CTA8.3, 4 cycle, turbo-charged and after cooled diesel with a displacement of 505 cu. in. (8.3 liters). Output is 260 HP (194 kw) @ 2,200 rpm with maximum torque of 650 ft. lbs. (1085 Nm) @ 1,500 rpm.

ENGINE OPTION

Caterpillar 3208T 4 cycle, turbo-charged diesel with a displacement of 635 cu. in. (10.4 liters). Output is 250 HP (187) @ 2,600 rpm with maximum torque of 644 ft. lbs (873 Nm) @ 1,800 rpm.

Electrical:

24 volt system with negative ground, two 8D batteries, and a 65 amp alternator.

Fuel Tank:

80 gallon (303 liter) capacity.

TRANSMISSION

Powershift with hi/lo range and torque convertor, eight speeds forward, six reverse.

Max Speed:

21 mph (34 km/h).

Max Grade:

104% @ stall.

Miscellaneous Equipment**(Standard):**

Sliding engine hood, front and rear tow lugs, automatic moisture ejector, air dryer, headlights, taillights, turn signals and flashers, back-up alarm, rearview mirrors.

Miscellaneous Equipment**(Optional):**

Engine starting aid, pintle hooks, floodlights, amber beacon, roof wiper, hydraulic air conditioner, and choice of propane or diesel heater.

PCSA Rating Class 10-283

Capacity charts and related lifting data can be found in a separate publication.

RT 175 WEIGHT DISTRIBUTION	POUNDS			KILOGRAMS		
	GROSS	FRONT	REAR	GROSS	FRONT	REAR
Basic Machine	98,200	50,120	48,080	44535	22725	21810
Additions for Options						
Telescoping Lattice Extension	2,640	3,460	-820	1195	1570	-375
Auxiliary Boom Point	190	600	-410	85	270	-185
Auxiliary Winch Wire Rope	547	-306	853	248	-139	387
75 Ton Hook Block (travel)	1,220	3,700	-2480	555	1680	-1125
15 Ton Headache Ball (boom)	470	1450	-980	215	660	-445

3105J113

NOTE: All designs, specifications, and components of the equipment described are subject to change at the manufacturer's sole discretion at any time and without advance notice. Capacity charts and information printed here are only a guide and may not be complete. They should not be relied upon to operate the crane. The individual load charts and related lifting data on each crane must be understood and govern operation of the crane. Data published herein is informational in nature and shall not be construed to warrant suitability of the machine for any particular purpose as performance may vary with conditions encountered. The only warranty applicable is our standard warranty for this machine.



P.O. Box 260002 Hwy. 501 East/Atlantic Center Conway, SC 29526-2602 U.S.A.
(803) 349-6900 FAX (803) 349-7090

