

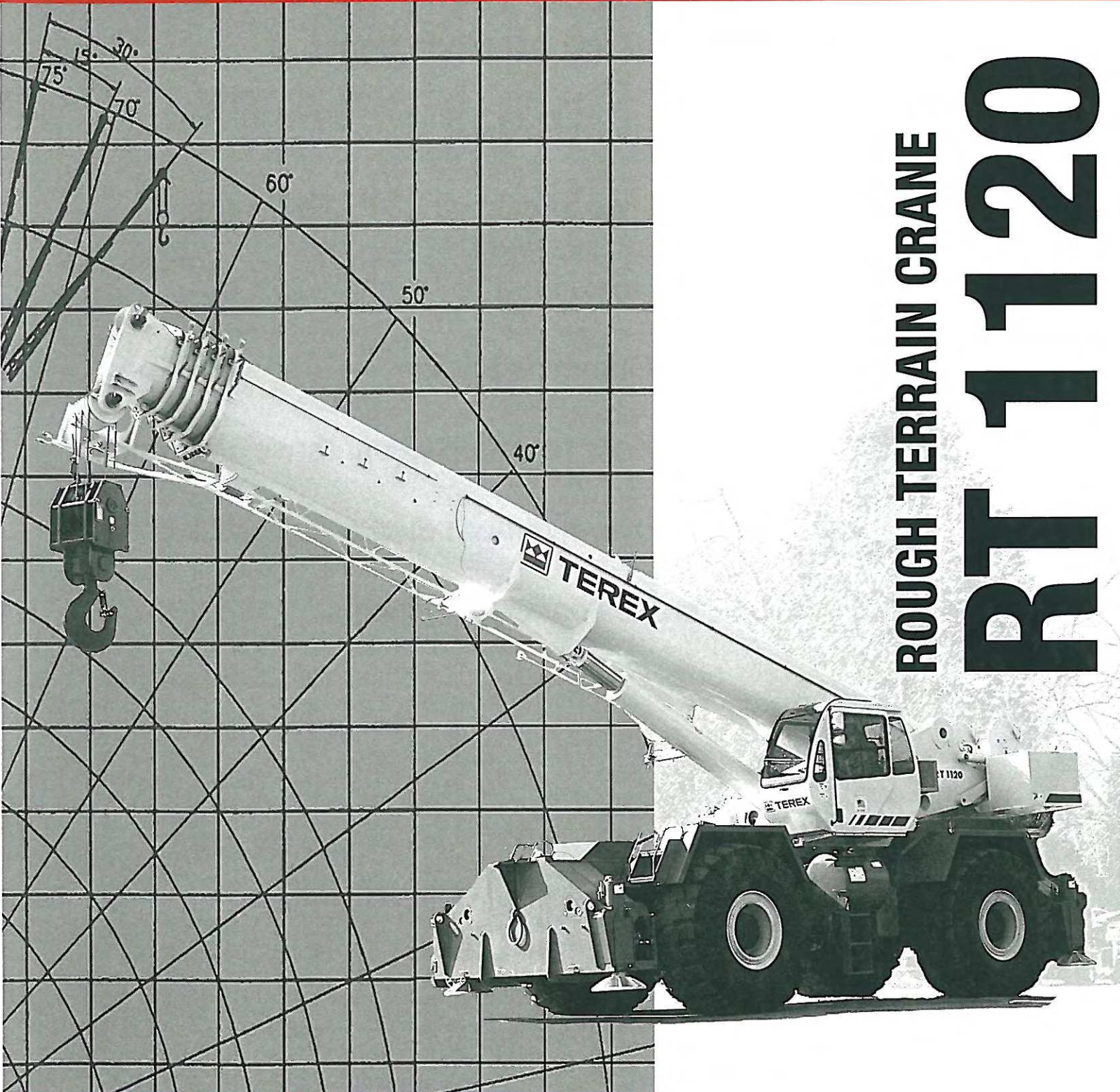

RT 1120 | Rough Terrain Crane



ROUGH TERRAIN CRANE
RT 1120

Specifications and Lifting Capacity



RT 1120

HIGHLIGHTS

- ▶ 155 ft. 5 Section 3 Mode Boom
- ▶ 30 ft.-56 ft. Bi-Fold Jib
- ▶ Optional two additional 26 ft. Jib Inserts
- ▶ Giving a maximum tip height of 271 ft.
- ▶ 300 HP Cummins Engine
- ▶ Hydraulically removable counterweight system
- ▶ Electric over hydraulic dual axis joystick controls
- ▶ Disc brakes on all four wheels

i | ROUGH TERRAIN CRANE
RT 1120

TABLE OF CONTENTS

▶ Specifications	1-4
▶ Load Charts	
Mode 1 (Synchronous Mode)	5
Mode 2 (Stability Mode)	6
Mode 3 (Strength Mode)	7
All Modes (1,2,3) 30 ft. Jib	8
All Modes (1,2,3) 56 ft. Jib	9
Range Diagram	10



TEREX®



TEREX®

RT 1100 SERIES

rough terrain crane
specification

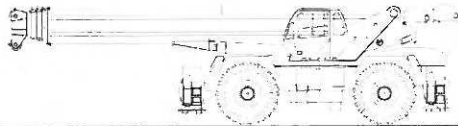

STANDARD BOOM EQUIPMENT

BOOM

41-155 ft. (12.52-47.24 m), five section, three mode, full power boom. Telescoping is electronically synchronized with single lever control. The extension system consists of one 2-stage telescope cylinder and one single stage telescope cylinder with wire rope used to extend and retract the tip section. The boom is a high-strength ovaloid design with anti-friction slide pads. Boom plates are made of high strength steel to reduce weight and increase strength. A single boom hoist cylinder provides for boom elevation of -3 to 80 degrees. Maximum tip height 164 ft (50.00 m).

BOOM HEAD

Welded to fifth section of boom. Five nylon load sheaves and two idler sheaves mounted on heavy duty, anti-friction bearings. Quick reeving boom head. A supplied removable mount allows the addition of the sixth and seventh load sheaves for heavy lifts. Provisions included for side-stow jib mounting.

OPTIONAL BOOM EQUIPMENT

JIBS

30 ft.(9.13 m) side stow swing-on one-piece lattice type jib. Single nylon sheave mounted on anti-friction bearing. Jib is offsettable at 0°, 20°, or 40°. Maximum tip height is 193 ft. (58.83 m).

30-56 ft. (9.13-17.00 m) side stow bi-fold lattice type jib. Single nylon sheave mounted on anti-friction bearing. Jib is extendible to 56 ft. (17.00 m) by means of a swing-on extension. Extension remains stowed on side of boom when not in use. Jib is offsettable at 0°, 20°, or 40°. Maximum tip height is 219 ft. (66.75 m).

Two 26 ft.(7.92 m) inserts are available to extend the maximum jib length to 108 ft.(32.92 m). Inserts do not stow on crane. Maximum tip height is 271 ft.(82.6 m)

RUNNER

5 ft (1.5 m) runner is equipped with two nylon sheaves mounted on anti-friction bearings. Installs in place of jib. High offset and dual load sheaves provides high lift capacities with greater offset than available from main boom head alone. Can be used simultaneously with main winch reeved over main boom head.

AUXILIARY BOOM HEAD

Removable auxiliary boom head has single nylon sheave mounted on anti-friction bearing. Removable pin-type rope guard for quick reeving. Installs on main boom head only.

HOOK BLOCK

Seven metallic sheaves on anti-friction bearings with hook and hook latch. Quick reeving design does not require removal of wedge and socket from rope.

HOOK & BALL

12 ton (10.9 mt) top swivel ball with hook and hook latch.



TEREX®

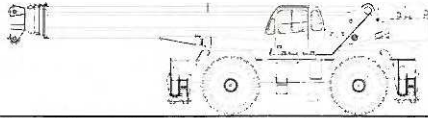

STANDARD UPPERSTRUCTURE EQUIPMENT

UPPERSTRUCTURE FRAME

All welded one-piece structure fabricated with high tensile strength alloy steel. Counterweight is pins to frame and hydraulically installed and removed.

TURNTABLE CONNECTION

Swing bearing is a single row, ball type, with internal teeth. The swing bearing is bolted to the revolving upperstructure and to the carrier frame.

SWING

One hydraulic motor drives dual double planetary reduction swing reducers for precise and smooth swing function. Swing speed (no load) is 1.5 rpm.

SWING BRAKE

Spring set hydraulically released swing parking brakes. Hydraulic foot controlled momentary swing brakes. A 360° mechanical house lock is standard.

RATED CAPACITY INDICATOR

Rated Capacity Indicator with visual and audible warning system and automatic function disconnects. Second generation pictographic display includes: boom radius, boom angle, boom length, allowable load, actual load, and percentage of allowable load registered by bar graph. Operator settable alarms provided for swing angle, boom length, boom angle, tip height, and work area exclusion zone.

OPERATOR'S CAB

Environmental cab with all steel construction includes; tinted safety glass throughout for optimum visibility and rubber floor matting mounted on vibration absorbing pads. The cab has a sliding door on the left side, framed sliding window on the right side, hinged tinted all glass skylight and removable front windshield to provide optimum visibility of the load open or closed. Hot air defroster keeps windshield clear. Acoustical foam padding insulates against sound and weather. The deluxe six-way adjustable seat is equipped with a mechanical suspension and includes head and arm rests.

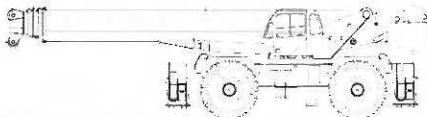

STANDARD CARRIER EQUIPMENT

CARRIER CHASSIS

Terex designed Chassis includes four wheel drive and four wheel steering. Has box-type construction with reinforcing cross members, a precision machined turn table mounting plate and integrally welded outrigger boxes. Decking has anti-skid surfaces (including between the frame rails), lockable front storage compartment and access steps with handles on the left and right sides of all four corners. Lights are recessed into the outrigger boxes for protection. Air reservoir drains are collected in an easily accessible central location.

AXLES AND SUSPENSION

Rear axle is a planetary drive/steer type with 10.0 in (0.25m) of total oscillation. Automatic oscillation lockouts engage when the superstructure is swung 10° in either direction. Front axle is a planetary drive/steer type, rigidly mounted to the frame for increased stability.

CONTROLS

Armrest mounted dual axis controls for winch(s), swing, and boom elevation. Winch rotation indication incorporated into control handles. Armrest swings up to improve access and egress. Vernier adjustable hand throttle included. Steering column mounted turn signal, wiper, and shift controls. Switches include ignition, engine stop, lights, horn, roof window wiper, defroster, steering mode, parking brake, outriggers, 360° house lock. Horn and winch speed shift switches are mounted in the levers. Foot control pedals include swing brake, boom telescope, service brake, and accelerator.

INSTRUMENTATION AND ACCESSORIES

In-cab gauges include air pressure, bubble level, engine oil pressure, fuel, engine temperature, voltmeter, transmission temperature, and transmission oil pressure. Indicators include low air, high water temperature, low oil pressure, high transmission temperature, low coolant level audio/visual warning, hoist drum rotation indicator(s), and Rated Capacity Indicator. Accessories include fire extinguisher; light package including headlights, tail light, brake lights, directional signals, four-way hazard flashers, dome light, and back-up lights with audible back-up alarm; windshield washer/wiper; skylight wiper; R.H. and L.H. rear view mirrors; dash lights; and seat belt. Circuit breakers protect electrical circuits.

HYDRAULIC CONTROL VALVES

Valves are mounted on the rear of the upperstructure and are easily accessible. Valves have electric/hydraulic operators and include one pressure compensated four spool valve for boom elevation and telescope. One pressure compensated two spool valve for main and auxiliary winch, and one single spool valve for swing. System provides for simultaneous operation of all crane functions. Quick disconnects are provided for ease of installation of pressure check gauges.

OPTIONAL EQUIPMENT

Auxiliary Winch • Single axis armrest mounted controllers • LP Heater/Defroster • Hydraulically powered Air Conditioner with or without Hydraulic Heater • Work Lights • Rotating Beacon

STEERING

Hydraulic four-wheel full power steering for two-wheel, four-wheel coordinated, or four-wheel crab steer is easily controlled by steering wheel. A rear axle centering light is provided.

	Turning Radius (to C of outside tire.)	Curb Clearance Radius
Two-wheel:	48' 3.5" (14.7 m)	50' 1.25" (15.27 m)
Four-wheel:	26' 3.25" (8.00 m)	28' 2.62" (8.60 m)

TRANSMISSION

Full power shift transmission with integral torque converter provides 6 speeds forward and 3 speeds reverse with neutral safety start. Four wheel drive engages only with first two gears and two wheel drive is available in all gears. A remote mounted oil filter provides easy access. Automatic pulsating back-up alarm.

ROUGH TERRAIN CRANE RT 1120 | 2

Courtesy of CraneMarket



TEREX®

STANDARD CARRIER EQUIPMENT (continued)

MULTI-POSITION OUT & DOWN OUTRIGGERS

Independent hydraulic outriggers may be utilized extended to 26 ft. (7.92 m) centerline to centerline, in their 1/2 extended position, or fully retracted for maximum flexibility. Easily removable 24" diameter (452 in² (2916 cm²) Almag floats stow on the outrigger boxes at their point of use. Complete controls and a sight leveling bubble are located in the operator's cab.

WHEELS & TIRES

Disc type wheels with full tapered bead seat rim. 180 in (4572 mm) wheelbase.

TIRES

Wide earthmover (E3) style tread tires provide life and flotation. 33.25x29-32 PR std. 29.50x29-34 PR optional

SERVICE BRAKES

Split system air over hydraulic 18.5" (470 mm) diameter disc dual caliper brakes on all wheels.

PARKING BRAKE

Electrically controlled front axle mounted spring-set, air released drum type parking brake with indicator light.

OPTIONAL EQUIPMENT

Immersion Heater • Pintle Hook • Clearance Lights • Independent Rear Wheel Steer • Four Mode Rear Wheel Steer • 20,000 lb Line Pull Front Mounted Winch

HYDRAULIC SYSTEM

HYDRAULIC PUMPS

Three single gear type pumps with a combined system capability of 156 gpm (592 lpm). Includes pump disconnect on winch and boom pumps.

Main and Auxiliary Winch Pump

66.6 gpm (252.1 lpm) @ 4,500 psi (316.4 kg/cm²)

Boom Hoist, Telescope Pump

66.6 gpm (252.1 lpm) @ 4,500 psi (316.4 kg/cm²)

Power Steering, Outrigger and Swing Pump

23.1 gpm (87.4 lpm) @ 3,500 psi (246.1 kg/cm²)

FILTRATION

Full flow oil filtration system with bypass protection includes a removable 60 mesh (250 micron) suction screen-type filter and two 5 micron synthetic depth type media replaceable return line filters.

HYDRAULIC RESERVOIR

All steel, welded construction with internal baffles and diffuser. Provides easy access to filters and is equipped with an external sight level gauge. The hydraulic tank is self-pressurizing to aid in keeping out contaminants and in reducing potential pump cavitation. Capacity is 304 gal (1,151 L). Hydraulic oil cooler is standard.

MAIN WINCH SPECIFICATION

Hydraulic winch with bent axis piston motor and planetary reduction gearing provides 2-speed operation with equal speeds for power up and down. Winch is equipped with an integral automatic brake, grooved drum, tapered flanges, standard cable roller on drum, and an electronic drum rotation indicator.

PERFORMANCE	LO-RANGE	HI-RANGE
Max. line speed (no load)		
First layer	199 fpm (60.6m/min)	328 fpm (100.0 m/min)
Fifth layer	274 fpm (83.5 m/min)	453 fpm (138.1 m/min)
Max. line pull-first layer	21,300 lbs (9 662 kg)	11,297 lbs (5 124 kg)
Max. line pull-fifth layer	15,454 lbs (7 010 kg)	8,180 lbs (3 710 kg)
Permissible line pull	16,800 lbs (7 530 kg)	

DRUM DIMENSIONS	DRUM CAPACITY
15.00 in (381 mm) drum diameter	Max. Storage: 1239 ft (377.6 m)
26.2 in (665 mm) length	Max. Useable: 1239 ft (377.6 m)
26.5 in (673 mm) flange dia.	*Based on minimum flange height above
Cable: 3/4" x 850 ft (19 mm x 278.9 m)	top layer to comply with ANSI B30.5
Cable type: 3/4" (19mm) 35x7 rotation resistant compacted strand.	
Min breaking strength 42 tons (38.1 mt)	

OPTIONAL AUX. WINCH

Hydraulic 2-speed winch with bent axis piston motor, equal speed power up and down, planetary reduction with integral automatic brake, grooved drum with tapered flanges, drum roller, and rotation indicator.

PERFORMANCE	
Max. line speed (no load)	
Fifth layer	453 fpm (138.1 m/min)
Max. line pull	
First layer	21,300 lbs (9 662 kg)

DRUM DIMENSIONS AND CAPACITY

(Same as main winch)

OPTIONAL HOIST LINE

MAIN WINCH AND OPTIONAL AUXILIARY WINCH-3/4" (19mm) XIPS, IWRC Right Regular Lay. Min breaking strength 29.4 tons (26.7 mt).

ENGINE SPECIFICATIONS

Make and Model	Cummins QSC-300
Type	6 cylinder
Bore and Stroke	4.49 x 5.31 in (114x134.9 mm)
Displacement	506 cu in (8.3 l)
Rated HP	300 hp (224 kw) @ 2200 rpm
Maximum Gross HP	300 hp (224 kw) @ 2200 rpm
Maximum Gross Torque	1000 lb•ft (1 356 N•m) @ 1400 rpm
Aspiration	turbocharged & charge air cooled
Air Filter	dry type
Electrical System	12 volt
Alternator	130 amp
Battery	(2) 12V-1900 CCA
Fuel Capacity	80 gal (303 l)

PERFORMANCE (Standard Engine)

Trans. Gear	Forward Drive	Maximum Speed	Maximum Tractive Effort	Gradeability @ Stall
1	4-wheel	1.6 mph (2.6 kph)	119,913 lbs (54 392 kg)	145.6%
2	4-wheel	2.3 mph (3.7 kph)	84,036 lbs (61 332 kg)	69.6%
3	2-wheel	4.4 mph (7.0 kph)	45,597 lbs (33 092 kg)	31.5%
4	2-wheel	6.2 mph (10.0 kph)	31,971 lbs (14 502 kg)	20.9%
5	2-wheel	14.3 mph (23.0 kph)	13,992 lbs (6 347 kg)	7.8%
6	2-wheel	20.4 mph (32.8 kph)	9,802 lbs (4 446 kg)	4.9%

All performance data is based on a gross vehicle weight of 142,000 lbs (64,410 kg), 32.25x29 tires, 4x4 drive. Performance may vary due to engine performance. Gradeability data is theoretical and limited by tire slip, machine stability, or oil pan design.



TEREX®

GENERAL DIMENSIONS

NOTES:

- Dimensions given assume the boom is fully retracted in travel position and 33.25x29 tires.
- Minimum ground clearance under:
 - transmission - 29.00"
 - axle bowls - 26.50"
 - tie rods - 26.50"

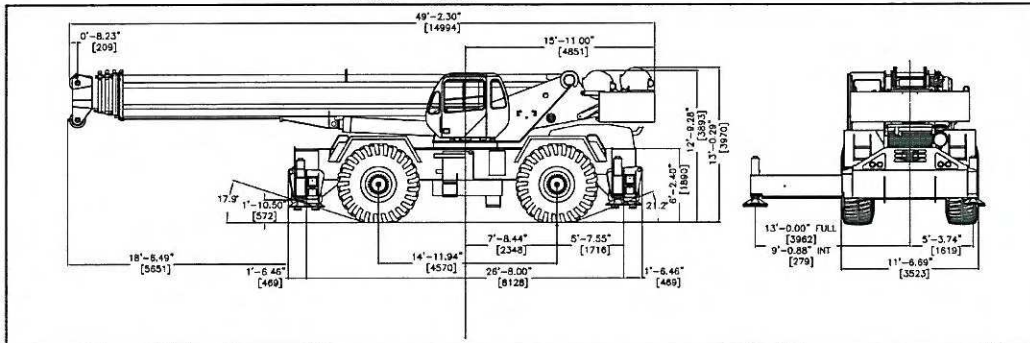

WEIGHTS & AXLE LOADS	GROSS WEIGHT LBS.	UPPER FACING FRONT		GROSS WEIGHT KG.	UPPER FACING FRONT	
		FRONT	REAR		FRONT	REAR
Basic crane with no counterweight, full fuel tank, 6x19 rope, 33.25x29 32 PR tires	103,672	68,881	34,286	47,021	31,241	15,551
Add 29,600 lb (13 426 kg) Counterweight	29,600	-11,725	41,325	13,425	-5,318	18,743
Add Options:						
30' (9.13 m) swing-on jib (Stowed)	+2,630	+4,594	-1,964	1,193	2,084	-891
30'-56' (9.13-17.0 m) swing-on jib (Stowed)	+3,640	+5,751	-2,111	1,651	2,608	-957
Auxiliary Boom Head	+170	+468	-298	77	212	-135
Auxiliary Winch with 850' of 6x19 class wire rope	+659	-253	912	299	-115	414
850' of Spin Resistant Rope (35x7) in lieu of 6x19						
Main Winch	+221	-50	+271	100	-23	123
Aux Winch	+221	-97	+318	100	-44	144
130T (117.9 mt) 7-sheave Hook Block	+2,310	+3,889	-1,579	1048	1,764	-716
100T (90.7 mt) 7-sheave Hook Block	+2,120	+3,569	-1,449	962	1,619	-657
75T (68.0 mt) 5-Sheave Hook Block	+1,608	+2,707	-1,099	729	1,228	-498
20T (18.1 mt) 1-Sheave Hook Block	+570	+960	-390	259	435	-177
12T (19.9 mt) Hook and Ball (in tool box)	+722	+749	-27	327	340	-12
Pintle Hook:						
Front	+45	+60	-15	20	27	-7
Rear	+45	-25	+70	20	-11	32
Substitute:						
29.5x29 34 PR Tires	-1,776	-888	-888	-806	-403	-403

NOTE: Weights are for Terex supplied equipment and are subject to 2% variation due to manufacturing tolerances.

WE RESERVE THE RIGHT TO AMEND THESE SPECIFICATIONS AT ANY TIME WITHOUT NOTICE. THE ONLY WARRANTY APPLICABLE IS OUR STANDARD WRITTEN WARRANTY APPLICABLE TO THE PARTICULAR PRODUCT AND SALE. WE MAKE NO OTHER WARRANTY, EXPRESSED OR IMPLIED.

ROUGH TERRAIN CRANE
RT 1120 | **4**

Courtesy of CraneMarket

Lifts with Outrigger Beams Fully Extended

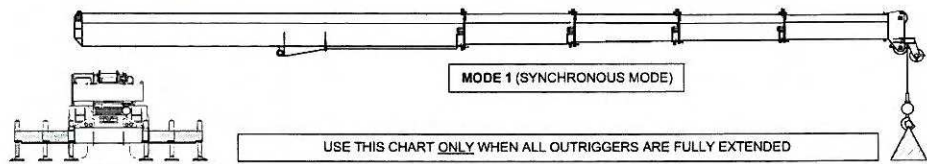

RATED LOAD ON OUTRIGGERS											
LOAD RADIUS (ft)	BOOM ANGLE (DEG) REF	OVER FRONT (lb)	360° (lb)	LOAD RADIUS (ft)	BOOM ANGLE (DEG) REF	OVER FRONT (lb)	360° (lb)	LOAD RADIUS (ft)	BOOM ANGLE (DEG) REF	OVER FRONT (lb)	360° (lb)
BOOM LENGTH 41.3 ft				BOOM LENGTH 60.0 ft				BOOM LENGTH 80.0 ft			
10.0	67.6	240,000 *	240,000 *	10.0	74.9	60,000 *	60,000 *	15.0	75.1	60,000 *	60,000 *
12.0	64.5	200,500 *	200,500 *	12.0	72.9	60,000 *	60,000 *	20.0	71.3	60,000 *	60,000 *
15.0	59.6	170,800 *	170,800 *	15.0	69.8	60,000 *	60,000 *	25.0	67.4	60,000 *	60,000 *
20.0	50.6	133,000 *	133,000 *	20.0	64.5	60,000 *	60,000 *	30.0	63.4	60,000 *	60,000 *
25.0	40.0	106,900 *	106,900 *	25.0	58.9	60,000 *	60,000 *	35.0	59.2	60,000 *	60,000 *
30.0	25.4	87,700 *	87,700 *	30.0	53.0	60,000 *	60,000 *	40.0	54.8	58,100	54,400
32.5	0.0	47,000 *	47,000 *	35.0	46.4	60,000 *	60,000 *	45.0	50.2	46,800	43,800
				40.0	38.9	57,300	53,500	50.0	45.1	38,500	36,000
				45.0	29.7	45,900	42,800	55.0	39.6	32,300	30,100
				50.0	15.2	37,300	34,700	60.0	33.2	27,300	25,400
				51.3	0.0	28,300 *	28,300 *	65.0	25.2	23,200	21,500
								70.0	12.7	19,700	18,200
								71.3	0.0	17,900 *	17,200
BOOM LENGTH 100.0 ft				BOOM LENGTH 120.0 ft				BOOM LENGTH 140.0 ft			
20.0	75.2	60,000 *	60,000 *	25.0	75.2	55,000 *	55,000 *	30.0	75.3	39,000 *	39,000 *
25.0	72.2	60,000 *	60,000 *	30.0	72.7	49,300 *	49,300 *	35.0	73.1	36,800 *	36,800 *
30.0	69.1	60,000 *	60,000 *	35.0	70.2	44,700 *	44,700 *	40.0	71.0	34,100 *	34,100 *
35.0	65.9	60,000 *	60,000 *	40.0	67.6	40,400 *	40,400 *	45.0	68.8	31,500 *	31,500 *
40.0	62.7	57,000 *	54,800	45.0	65.0	37,300 *	37,300 *	50.0	66.5	28,900 *	28,900 *
45.0	59.4	47,200	44,200	50.0	62.3	34,400 *	34,400 *	55.0	64.3	27,000 *	27,000 *
50.0	55.9	39,000	36,400	55.0	59.5	31,500 *	30,700	60.0	61.9	25,300 *	25,300 *
55.0	52.3	32,700	30,500	60.0	56.6	28,000	26,100	65.0	59.6	23,500 *	22,400
60.0	48.5	27,700	25,800	65.0	53.7	24,000	22,300	70.0	57.1	20,800	19,300
65.0	44.4	23,800	22,100	70.0	50.6	20,700	19,200	75.0	54.6	18,100	16,700
70.0	40.0	20,500	18,900	75.0	47.3	17,900	16,600	80.0	52.0	15,700	14,500
75.0	35.0	17,700	16,300	80.0	43.9	15,600	14,300	85.0	49.3	13,700	12,500
80.0	29.4	15,300	14,000	85.0	40.2	13,600	12,400	90.0	46.5	12,000	10,900
85.0	22.3	13,200	12,000	90.0	36.2	11,800	10,700	95.0	43.5	10,400	9,400
90.0	11.1	11,300	10,200	95.0	31.8	10,200	9,200	100.0	40.4	9,000	8,100
91.3	0.0	10,700	9,600	100.0	26.6	8,800	7,900	105.0	37.0	7,800	6,900
				105.0	20.2	7,600	6,700	110.0	33.3	6,700	5,900
				110.0	10.0	6,300	5,500	115.0	29.2	5,700	4,900
				111.3	0.0	6,000	5,100	120.0	24.5	4,800	4,000
BOOM LENGTH 155.0 ft				BOOM EXTENSION INFORMATION							
35.0	74.8	27,500 *	27,500 *	II	0%	16%	35%				
40.0	72.9	27,000 *	27,000 *	III	0%	16%	35%				
45.0	70.9	26,500 *	26,500 *	IV	0%	16%	35%				
50.0	68.9	24,900 *	24,900 *	V	0%	16%	35%				
55.0	66.9	23,300 *	23,300 *								
60.0	64.9	21,900 *	21,900 *	100'	120'	140'					
65.0	62.8	20,600 *	20,600 *	II	52%	70%	87%				
70.0	60.7	19,300 *	19,300 *	III	52%	70%	87%				
75.0	58.5	18,100 *	17,000	IV	52%	70%	87%				
80.0	56.3	16,000	14,800	V	52%	70%	87%				
85.0	54.0	14,000	12,900								
90.0	51.6	12,300	11,200	155'							
95.0	49.2	10,700	9,700	II	100%						
100.0	46.7	9,400	8,400	III	100%						
105.0	44.0	8,200	7,300	IV	100%						
110.0	41.2	7,100	6,200	V	100%						
115.0	38.2	6,100	5,300								
120.0	35.1	5,200	4,400								
125.0	31.6	4,400	3,600								
130.0	27.7	3,600	2,900								
135.0	23.2	2,900	2,200								
140.0	17.6	2,200	1,600								
145.0	8.5	1,600									
146.2	0.0	1,300									

MAIN BOOM-MODE 1 (SYNCHRONOUS MODE)

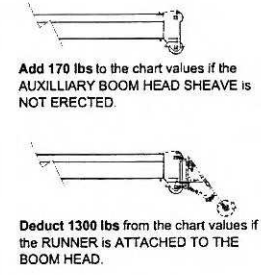

Lifts with Outrigger Beams Fully Extended

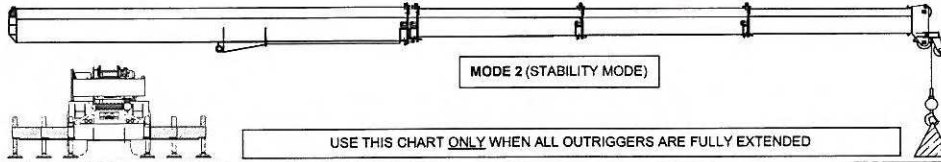

RATED LOAD ON OUTRIGGERS															
LOAD RADIUS (ft)	BOOM ANGLE (DEG) REF	OVER FRONT (lb)	360° (lb)	LOAD RADIUS (ft)	BOOM ANGLE (DEG) REF	OVER FRONT (lb)	360° (lb)	LOAD RADIUS (ft)	BOOM ANGLE (DEG) REF	OVER FRONT (lb)	360° (lb)	LOAD RADIUS (ft)	BOOM ANGLE (DEG) REF	OVER FRONT (lb)	360° (lb)
BOOM LENGTH 41.3 ft				BOOM LENGTH 60.0 ft				BOOM LENGTH 80.0 ft							
10.0	57.6	240,000 *	240,000 *	10.0	74.9	60,000 *	60,000 *	15.0	75.1	60,000 *	60,000 *	20.0	71.3	60,000 *	60,000 *
12.0	54.5	200,500 *	200,500 *	12.0	72.9	60,000 *	60,000 *	20.0	67.4	60,000 *	60,000 *	25.0	67.4	60,000 *	60,000 *
15.0	59.6	170,800 *	170,800 *	15.0	69.8	60,000 *	60,000 *	30.0	63.4	60,000 *	60,000 *	30.0	63.4	60,000 *	60,000 *
20.0	50.6	133,000 *	133,000 *	20.0	64.5	60,000 *	60,000 *	35.0	59.2	60,000 *	60,000 *	35.0	59.2	60,000 *	60,000 *
25.0	40.0	106,900 *	106,900 *	25.0	58.9	60,000 *	60,000 *	40.0	54.8	59,900 *	56,800 *	40.0	54.8	59,900 *	56,800 *
30.0	25.4	87,700 *	87,700 *	30.0	53.0	60,000 *	60,000 *	45.0	50.2	49,100 *	46,100 *	45.0	50.2	49,100 *	46,100 *
32.6	0.0	47,000 *	47,000 *	35.0	46.4	60,000 *	60,000 *	50.0	45.1	40,800 *	38,300 *	50.0	45.1	40,800 *	38,300 *
				40.0	38.9	58,900 *	55,100 *	55.0	39.6	34,500 *	32,300 *	55.0	39.6	34,500 *	32,300 *
				45.0	29.7	47,400 *	44,400 *	60.0	33.2	29,400 *	27,500 *	60.0	33.2	29,400 *	27,500 *
				50.0	15.2	38,800 *	36,300 *	65.0	25.2	25,400 *	23,700 *	65.0	25.2	25,400 *	23,700 *
				51.3	0.0	29,300 *	29,300 *	70.0	12.7	21,800 *	20,300 *	70.0	12.7	21,800 *	20,300 *
								71.3	0.0	19,400 *	19,300 *	71.3	0.0	19,400 *	19,300 *
BOOM LENGTH 100.0 ft				BOOM LENGTH 120.0 ft				BOOM LENGTH 140.0 ft							
20.0	75.2	59,100 *	59,100 *	25.0	75.2	43,900 *	43,900 *	30.0	75.3	35,700 *	35,700 *	30.0	75.3	35,700 *	35,700 *
25.0	72.2	52,700 *	52,700 *	30.0	72.7	38,700 *	38,700 *	35.0	73.1	33,100 *	33,100 *	35.0	73.1	33,100 *	33,100 *
30.0	69.1	46,200 *	46,200 *	35.0	70.2	34,800 *	34,800 *	40.0	71.0	30,400 *	30,400 *	40.0	71.0	30,400 *	30,400 *
35.0	65.9	41,500 *	41,500 *	40.0	67.6	30,900 *	30,900 *	45.0	68.8	27,800 *	27,800 *	45.0	68.8	27,800 *	27,800 *
40.0	62.7	37,500 *	37,500 *	45.0	65.0	28,500 *	28,500 *	50.0	66.5	25,300 *	25,300 *	50.0	66.5	25,300 *	25,300 *
45.0	59.4	33,500 *	33,500 *	50.0	62.3	26,100 *	26,100 *	55.0	64.3	23,600 *	23,600 *	55.0	64.3	23,600 *	23,600 *
50.0	55.9	30,700 *	30,700 *	55.0	59.5	23,700 *	23,700 *	60.0	61.9	22,000 *	22,000 *	60.0	61.9	22,000 *	22,000 *
55.0	52.3	28,400 *	28,400 *	60.0	56.6	21,600 *	21,600 *	65.0	59.6	20,400 *	20,400 *	65.0	59.6	20,400 *	20,400 *
60.0	48.5	26,200 *	26,200 *	65.0	53.7	20,200 *	20,200 *	70.0	57.1	18,700 *	18,700 *	70.0	57.1	18,700 *	18,700 *
65.0	44.4	23,900 *	23,900 *	70.0	50.6	18,900 *	18,900 *	75.0	54.6	17,600 *	17,600 *	75.0	54.6	17,600 *	17,600 *
70.0	40.0	22,400 *	21,400 *	75.0	47.3	17,500 *	17,500 *	80.0	52.0	16,700 *	15,900 *	80.0	52.0	16,700 *	15,900 *
75.0	35.0	20,100 *	18,700 *	80.0	43.9	16,100 *	16,100 *	85.0	49.3	15,100 *	14,000 *	85.0	49.3	15,100 *	14,000 *
80.0	29.4	17,700 *	16,400 *	85.0	40.2	15,100 *	15,000 *	90.0	46.5	13,400 *	12,300 *	90.0	46.5	13,400 *	12,300 *
85.0	22.3	15,600 *	14,400 *	90.0	36.2	14,300 *	13,300 *	95.0	43.5	11,800 *	10,800 *	95.0	43.5	11,800 *	10,800 *
90.0	11.1	13,700 *	12,600 *	95.0	31.8	12,800 *	11,800 *	100.0	40.4	10,400 *	9,500 *	100.0	40.4	10,400 *	9,500 *
91.3	0.0	13,100 *	12,000 *	100.0	26.6	11,400 *	10,500 *	105.0	37.0	9,200 *	8,300 *	105.0	37.0	9,200 *	8,300 *
				105.0	20.2	10,100 *	9,200 *	110.0	33.3	8,100 *	7,200 *	110.0	33.3	8,100 *	7,200 *
				110.0	10.0	8,900 *	8,000 *	115.0	29.2	7,100 *	6,300 *	115.0	29.2	7,100 *	6,300 *
				111.3	0.0	8,500 *	7,700 *	120.0	24.5	6,200 *	5,400 *	120.0	24.5	6,200 *	5,400 *
BOOM LENGTH 155.0 ft				BOOM EXTENSION INFORMATION											
35.0	74.8	27,500 *	27,500 *	41.3' 60' 80'											
40.0	72.9	27,000 *	27,000 *	II 0%	0%	0%									
45.0	70.9	26,500 *	26,500 *	III 0%	22%	45%									
50.0	68.9	24,900 *	24,900 *	IV 0%	22%	45%									
55.0	66.9	23,300 *	23,300 *	V 0%	22%	45%									
60.0	64.9	21,900 *	21,900 *	100' 120' 140'											
65.0	62.8	20,600 *	20,600 *	II 0%	0%	47%									
70.0	60.7	19,300 *	19,300 *	III 69%	92%	100%									
75.0	58.5	18,100 *	17,000 *	IV 69%	92%	100%									
80.0	56.3	16,000 *	14,800 *	V 69%	92%	100%									
85.0	54.0	14,000 *	12,900 *	155'											
90.0	51.6	12,300 *	11,200 *	II 100%											
95.0	49.2	10,700 *	9,700 *	III 100%											
100.0	46.7	9,400 *	8,400 *	IV 100%											
105.0	44.0	8,200 *	7,300 *	V 100%											
110.0	41.2	7,100 *	6,200 *												
115.0	38.2	6,100 *	5,300 *												
120.0	35.1	5,200 *	4,400 *												
125.0	31.6	4,400 *	3,800 *												
130.0	27.7	3,600 *	2,900 *												
135.0	23.2	2,900 *	2,200 *												
140.0	17.6	2,200 *	1,600 *												
145.0	8.5	1,600 *													
146.2	0.0	1,300 *													

MAIN BOOM-MODE 2 (STABILITY MODE)

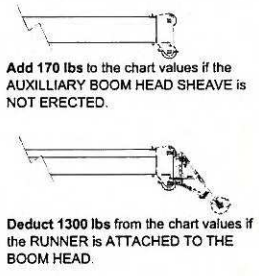

Lifts with Outrigger Beams Fully Extended

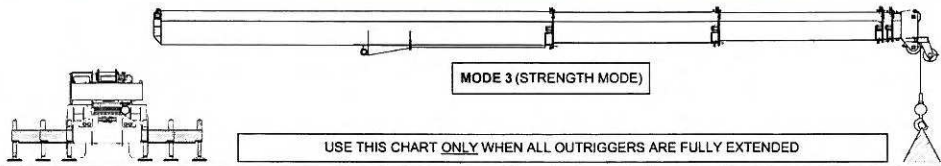

RATED LOAD ON OUTRIGGERS											
LOAD RADIUS (ft)	BOOM ANGLE (DEG) REF	OVER FRONT (lb)	360° (lb)	LOAD RADIUS (ft)	BOOM ANGLE (DEG) REF	OVER FRONT (lb)	360° (lb)	LOAD RADIUS (ft)	BOOM ANGLE (DEG) REF	OVER FRONT (lb)	360° (lb)
BOOM LENGTH 41.3 ft				BOOM LENGTH 60.0 ft				BOOM LENGTH 80.0 ft			
10.0	67.6	240,000 *	240,000 *	10.0	74.9	125,000 *	125,000 *	15.0	75.1	105,200 *	105,200 *
12.0	64.5	200,500 *	200,500 *	12.0	72.9	125,000 *	125,000 *	20.0	71.3	89,100 *	89,100 *
15.0	59.6	170,800 *	170,800 *	15.0	69.8	125,000 *	125,000 *	25.0	67.4	76,000 *	76,000 *
20.0	50.6	133,000 *	133,000 *	20.0	64.5	120,900 *	120,900 *	30.0	63.4	66,900 *	66,900 *
25.0	40.0	106,900 *	106,900 *	25.0	58.9	106,200 *	106,200 *	35.0	59.2	57,800 *	57,800 *
30.0	25.4	87,700 *	87,700 *	30.0	53.0	87,400 *	87,300 *	40.0	54.8	51,700 *	48,300 *
32.6	0.0	47,000 *	47,000 *	35.0	46.4	69,700 *	63,900 *	45.0	50.2	41,900 *	38,200 *
				40.0	38.9	53,600 *	49,100 *	50.0	45.1	33,900 *	30,800 *
				45.0	29.7	42,500 *	38,800 *	55.0	39.6	27,900 *	25,200 *
				50.0	15.2	34,100 *	31,000 *	60.0	33.2	23,100 *	20,700 *
				51.3	0.0	26,300 *	26,300 *	65.0	25.2	19,100 *	17,000 *
								70.0	12.7	15,700 *	13,800 *
								71.3	0.0	14,700 *	12,800 *

MAIN BOOM-MODE 3 (STRENGTH MODE)

BOOM LENGTH 98.2 ft				BOOM LENGTH 120.0 ft				BOOM LENGTH 140.0 ft			
15.0	77.9	79,500 *	79,500 *	25.0	75.2	52,000 *	52,000 *	30.0	75.3	37,800 *	37,800 *
20.0	74.9	72,500 *	72,500 *	30.0	72.7	48,000 *	48,000 *	35.0	73.1	35,800 *	35,800 *
25.0	71.8	63,900 *	63,900 *	35.0	70.2	43,900 *	43,900 *	40.0	71.0	33,700 *	33,700 *
30.0	68.7	56,000 *	56,000 *	40.0	67.6	39,700 *	39,700 *	45.0	68.8	31,500 *	31,500 *
35.0	65.5	49,800 *	49,800 *	45.0	65.0	36,200 *	36,200 *	50.0	66.5	29,200 *	29,200 *
40.0	62.2	44,500 *	44,500 *	50.0	62.3	33,000 *	33,000 *	55.0	64.3	27,200 *	27,200 *
45.0	58.7	39,100 *	37,700 *	55.0	59.5	29,700 *	27,400 *	60.0	61.9	25,200 *	24,600 *
50.0	55.2	33,500 *	30,400 *	60.0	56.6	25,300 *	22,900 *	65.0	59.6	23,000 *	20,900 *
55.0	51.5	27,500 *	24,800 *	65.0	53.7	21,400 *	19,300 *	70.0	57.1	19,800 *	17,900 *
60.0	47.5	22,700 *	20,400 *	70.0	50.6	18,200 *	16,300 *	75.0	54.6	17,100 *	15,300 *
65.0	43.3	18,900 *	16,800 *	75.0	47.3	15,500 *	13,800 *	80.0	52.0	14,800 *	13,200 *
70.0	38.6	15,700 *	13,800 *	80.0	43.9	13,300 *	11,600 *	85.0	49.3	12,800 *	11,300 *
75.0	33.4	13,000 *	11,300 *	85.0	40.2	11,300 *	9,800 *	90.0	46.5	11,100 *	9,700 *
80.0	27.3	10,700 *	9,200 *	90.0	36.2	9,500 *	8,200 *	95.0	43.5	9,500 *	8,200 *
85.0	19.3	8,700 *	7,200 *	95.0	31.8	8,000 *	6,700 *	100.0	40.4	8,200 *	7,000 *
89.4	0.0	6,800 *	5,400 *	100.0	26.6	6,700 *	5,500 *	105.0	37.0	7,000 *	5,800 *
				105.0	20.2	5,400 *	4,300 *	110.0	33.3	5,900 *	4,800 *
				110.0	10.0	4,200 *	3,100 *	115.0	29.2	4,900 *	3,900 *
				111.3	0.0	3,800 *	2,700 *	120.0	24.5	4,000 *	3,000 *
								125.0	18.6	3,100 *	2,200 *
								130.0	9.1	2,300 *	1,400 *
								131.3	0.0	2,000 *	1,100 *

BOOM EXTENSION INFORMATION		
41.3'	60'	80'
II 0%	33%	68%
III 0%	33%	68%
IV 0%	0%	0%
V 0%	0%	0%
100'	120'	140'
II 100%	100%	100%
III 100%	100%	100%
IV 0%	38%	74%
V 0%	38%	74%
155'		
II 100%		
III 100%		
IV 100%		
V 100%		

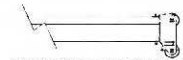

Add 170 lbs to the chart values if the AUXILIARY BOOM HEAD SHEAVE is NOT ERRECTED.

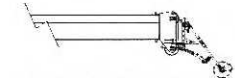

Deduct 1300 lbs from the chart values if the RUNNER is ATTACHED TO THE BOOM HEAD.

Lifts with Outrigger Beams Fully Extended

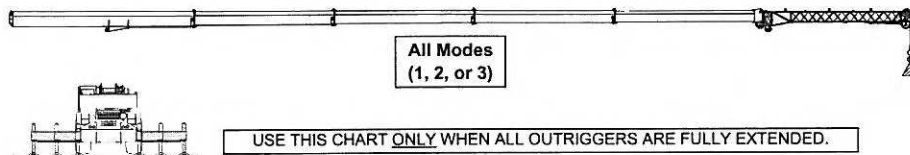

30 FT OFFSET JIB, MAIN BOOM FULLY EXTENDED						
LOADED BOOM ANGLE (DEG)	0° OFFSET		20° OFFSET		40° OFFSET	
	(REF) LOAD RADIUS (FT)	360° (LB)	(REF) LOAD RADIUS (FT)	360° (LB)	(REF) LOAD RADIUS (FT)	360° (LB)
79	51	16900 *	58	15700 *	63	12900 *
77	57	16300 *	64	15000 *	69	12500 *
75	63	15600 *	69	14300 *	75	12100 *
73	68	14900 *	75	13600 *	80	11600 *
71	74	14100 *	80	12900 *	85	11100 *
68	82	13000 *	88	11800 *	93	10400 *
65	89	11800 *	96	10800 *	100	9600 *
62	97	10400 *	103	9300 *	107	8700 *
59	104	8600 *	110	7800 *	114	7900 *
55	113	6500 *	118	6000 *	122	5800 *
51	121	4800 *	127	4500 *	130	4200 *
47	129	3500 *	134	3300 *	137	2900 *
43	137	2400 *	141	2300 *	143	2000 *

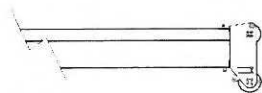

Add 170 lbs to the chart values if the AUXILLIARY BOOM HEAD SHEAVE is NOT ERECTED.

SET-UP:

- 1 Crane load ratings are based on the crane being leveled and standing on a firm, uniform supporting surface.
- 2 Crane load ratings on outriggers are based on all outriggers being fully extended, or in the case of partial extension ratings mechanically pinned in the appropriate position, and the tires free of the supporting surface.

**30 FT JIB
LIFT CAPACITIES**

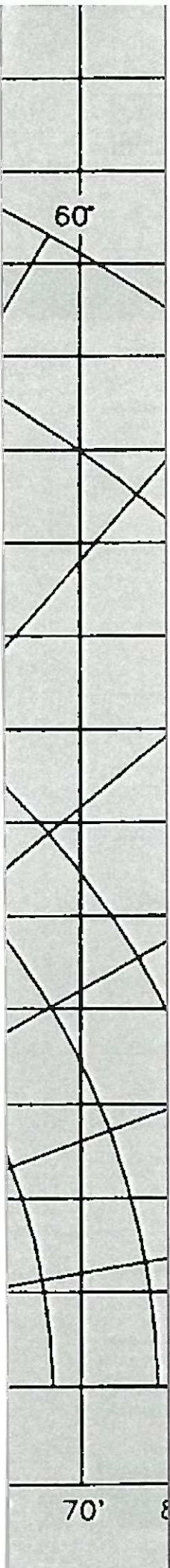

The Information contained in this brochure / product catalogue merely consists of general descriptions and a broad compilation of performance features which might not apply precisely as described under specific application conditions or which may change as a result of further product development.

The Desired performance features only become binding once agreed in the final contract.

Subject to change without notice!



TEREX®

106 12th Street SE
Waverly, IA 50677-9466 USA
TEL (319) 352-3920

WEB terex-cranes.com