



**CRAWLER CRANE  
CC 8800-1**

**DATASHEET METRIC**

# CC 8800-1





**WORKS FOR YOU.™**

*Courtesy of Crane.Market*

	Page · Seite · Page:
<b>Specifications · Technische Daten · Caractéristiques</b> .....	5
<b>Boom combinations · Ausleger-Kombinationen · Combinaisons de flèche</b> .....	10
<b>Superlift configurations · Superlift-Konfigurationen · Combinaisons Superlift</b> .....	12
<b>Main boom with SL · Hauptausleger mit SL · Flèche principale avec SL (SSL, HSSL, SSL / LSL)</b> .....	13
<b>Luffing fly jib with SL · Wippbarer Hilfsausleger mit SL · Fléchette à volée variable avec SL (SWSL / SFSL)</b> .....	17
<b>Fixed fly jib with SL · Starrer Hilfsausleger mit SL · Fléchette fixe avec SL (SFVL)</b> .....	51
<b>Technical description · Technische Beschreibung · Descriptif technique</b> .....	54

## Zeichenerklärung · Légende

 Track · Spur · Voie

 Counterweight + central ballast (ZB) · Gegengewicht + Zentralballast (ZB) · Contrepoids + lest central (ZB)

 Superlift counterweight · Superlift-Gegengewicht · Contrepoids Superlift

 Superlift radius · Superlift-Radius · Rayon Superlift

 Load radius · Lastradius · Portée

 Main boom · Hauptausleger · Flèche principale

 Fly jib · Hilfsausleger · Fléchette

 Main boom angle · Hauptauslegerwinkel · Jarret de flèche principale

 Fly jib angle · Hilfsauslegerwinkel · Jarret de fléchette

 Wind speed in m/s (meter per second) · Windgeschwindigkeit in m/s · Vitesse du vent en m/s

„D“



S: heavy · schwer · lourd

L: light · leicht · léger

H: Main boom · Hauptausleger · Flèche principale

W: Luffing fly jib · Wippbarer Hilfsausleger · Fléchette à volée variable

F: Fixed fly jib · Starrer Hilfsausleger · Fléchette fixe

SL: Superlift

V: Vessellift

SGL: Heavy base length · Schwere Grundlänge · Longueur de base lourde

# HIGHLIGHTS

CC 8800-1

## Features:

- ▶ Max. capacity 1600 t
  - ▶ Max. load moment 24002 mt
  - ▶ Superlift radii 19-30 m
  - ▶ Excellent capacities at the luffing fly jib
  - ▶ Redundant drivelines
  - ▶ 400 V power supply
  - ▶ Optional TWIN-Kit for capacities up to 3200 t
- 
- ▶ Max. Tragfähigkeit 1600 t
  - ▶ Max. Lastmoment 24002 mt
  - ▶ Superliftradien 19-30 m
  - ▶ Ausgezeichnete Tragfähigkeiten am wipbaren Hilfsausleger
  - ▶ Redundante Antriebseinheiten
  - ▶ 400 V Stromaggregat
  - ▶ Optionales TWIN-Kit für Tragfähigkeiten bis 3200 t
- 
- ▶ Capacité maximale de 1600 t
  - ▶ Moment de charge maximum 24002 mt
  - ▶ Radius superlift 19-30 m
  - ▶ Excellentes capacités avec la volée variable
  - ▶ Double unité d'entraînement
  - ▶ Groupe électrogène de 400 V
  - ▶ En option le kit TWIN pour des capacités jusqu'à 3200 t

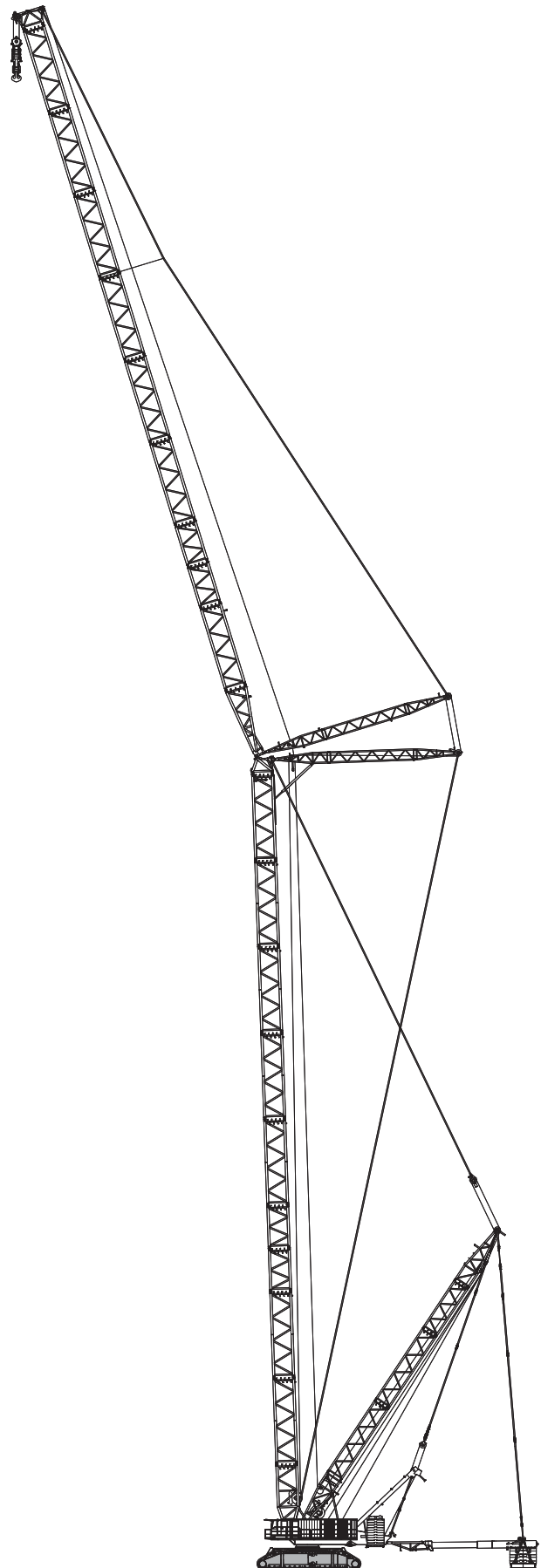

# SPECIFICATIONS

CC 8800-1

## Technische Daten · Caractéristiques

Working speeds (infinitely variable) · Arbeitsgeschwindigkeiten (stufenlos regelbar) ·  
Vitesses de travail (réglables sans paliers)

Mechanisms Antriebe Mécanismes	Rope $\varnothing$ Seil- $\varnothing$ $\varnothing$ du câble	Speeds <sup>1)</sup> Geschwindigkeiten <sup>1)</sup> Vitesses <sup>1)</sup>	Single line pull <sup>2)</sup> Seilzug je Strang <sup>2)</sup> Effort sur brin simple <sup>2)</sup>	Length of hoist rope Länge des Hubseils Longueur du câble de levage
Hoist I+II (H1+H2) Hubwerk I+II (H1+H2) Treuil de levage I+II (H1+H2)	40 mm	max. 120 m / min	352 kN / 316 kN	1540 m
Runner winch R (H3) – option Runnerwinde R (H3) – Option Tambour potence R (H3) – option	40 mm	max. 90 m / min	352 kN	700 m
Boom derricking (W2) Wippwerk Hauptausleger (W2) Variation de flèche (W2)	40 mm	max. 120 m / min		
Boom hoist (E) Einziehwerk (E) Relevage de flèche (E)	40 mm	max. 40 m / min		
Jib luffing (W1) Wippwerk Hilfsausleger (W1) Variation de volée (W1)	40 mm	max. 105 m / min		
Slewing (rpm) Drehwerk (U/min) Orientation (tr/mn)		0 – 0,6 <sup>1</sup> /min		

<sup>1)</sup> top layers · oberste Lagen · couches supérieures

<sup>2)</sup> without / with reeving effect considered · Angabe ohne / mit Wirkungsgrad der Einscherung · sans / avec effort de mouflage

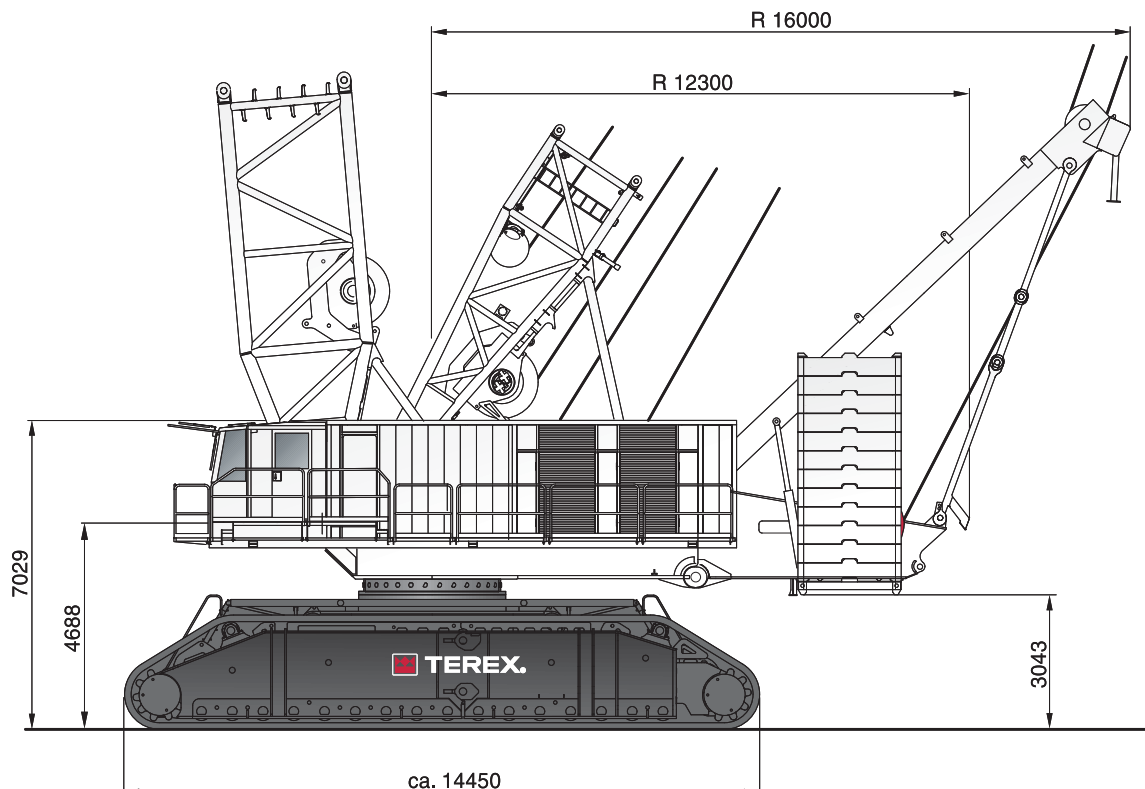

# SPECIFICATIONS

CC 8800-1

## Technische Daten · Caractéristiques

### Carrier performance · Fahrleistungen · Performances du porteur

1 <sup>st</sup> gear · 1. Gang · 1 <sup>ère</sup> vitesse	max. 0,4 km/h
2 <sup>nd</sup> gear · 2. Gang · 2 <sup>ème</sup> vitesse	max. 0,8 km/h

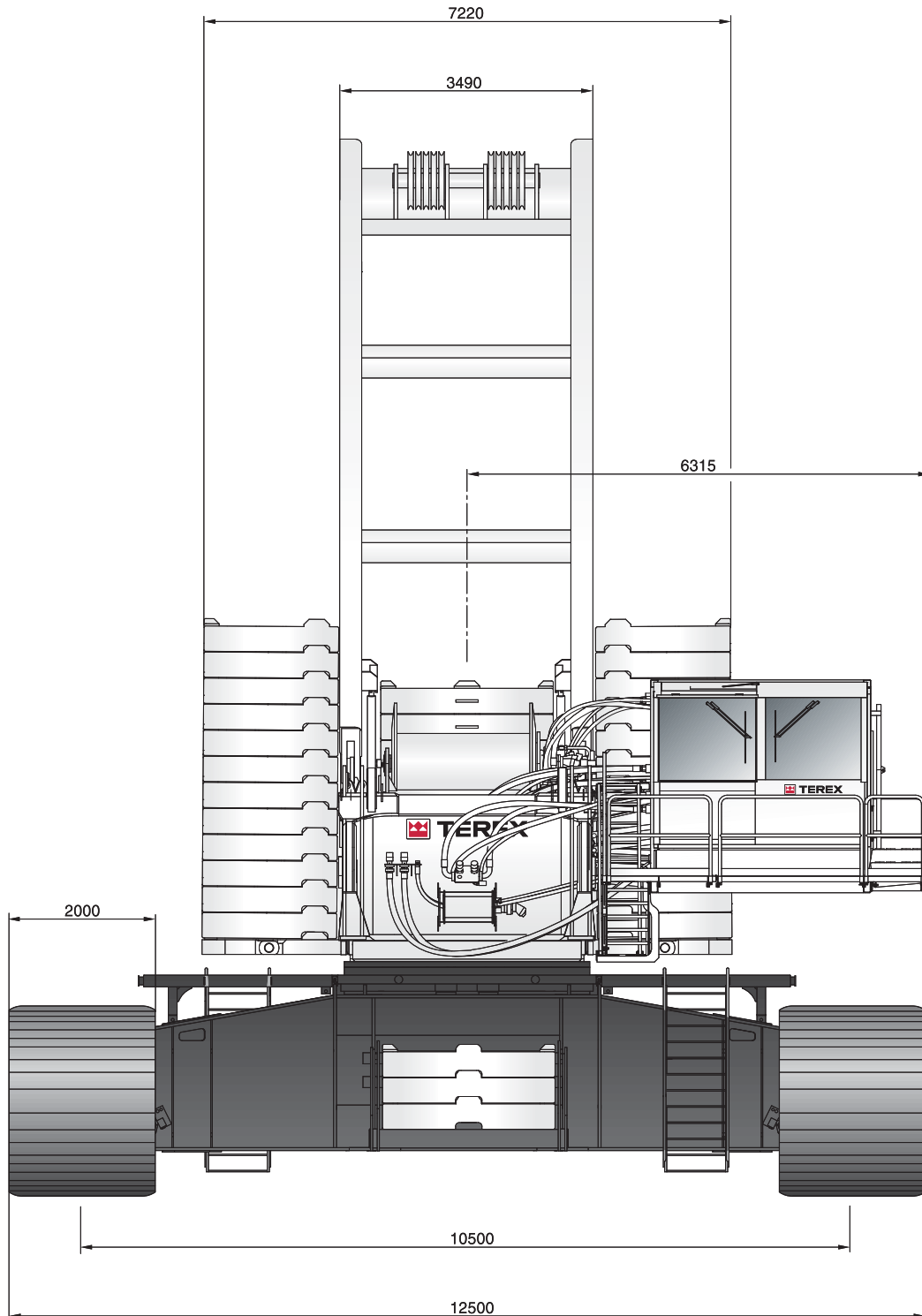

# SPECIFICATIONS

CC 8800-1

## Technische Daten · Caractéristiques

### Hook block system · Unterflaschensystem · Système de crochet-moufle

Type Typ Type	Possible load Mögliche Traglast Charge possible	Number of sheaves Anzahl der Rollen Nombre de poulies	Number of lines Strangzahl Nombre de brins	Weight Gewicht Poids	„D“
2 x 800	1600 t	2 x 13	2 x 26	44 t	8,70 m
	800 t	2 x 7	2 x 12	28 t / 18 t	6,50 m
	800 t	1 x 13	2 x 12	28 t / 18 t	6,20 m
	495 t	1 x 7	1 x 14	22 t / 8,5 t	6,50 m
2 x 675	1350 t	2 x 10	2 x 21	40 t / 21 t	8,50 m
	675 t	2 x 5	2 x 11	16 t / 12,5 t	6,00 m
	675 t	1 x 10	1 x 21	16 t / 12,5 t	6,00 m
	370 t	1 x 5	1 x 11	14,5 t / 8 t	6,00 m
100	100 t	1 x 1	1 x 3	7,7 t / 3,7 t	4,50 m

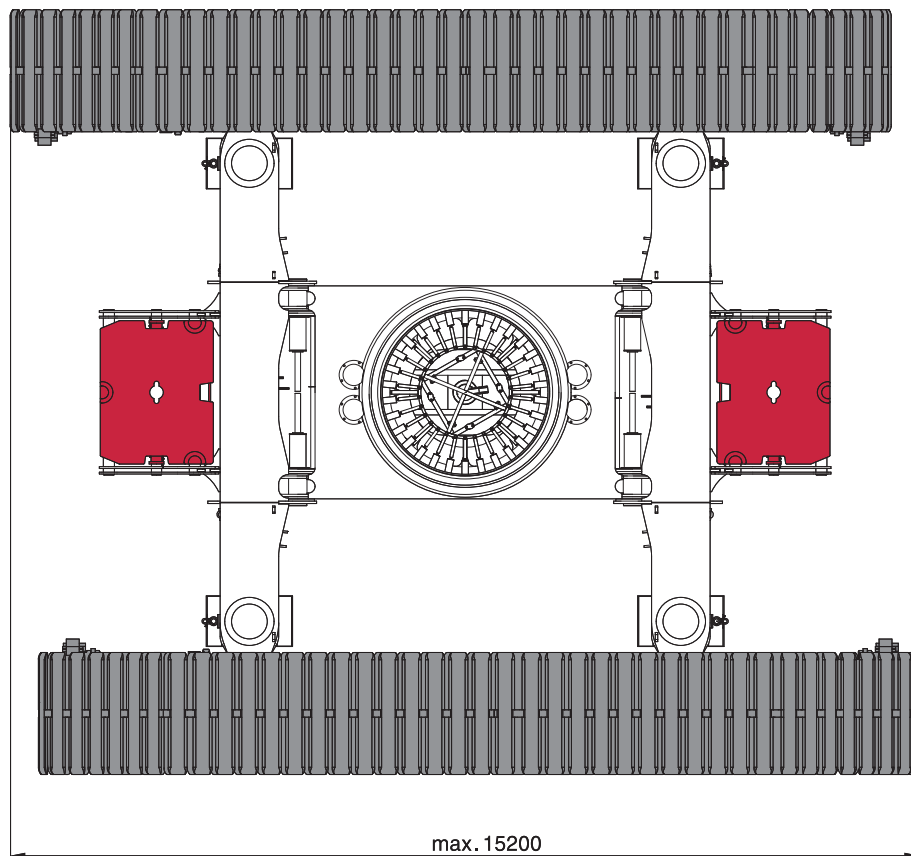

# SPECIFICATIONS

CC 8800-1

Technische Daten · Caractéristiques

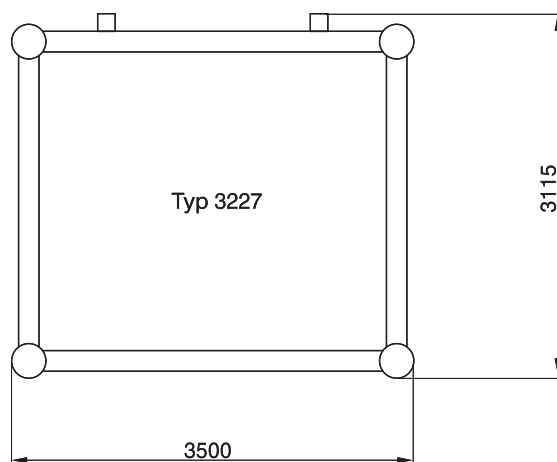
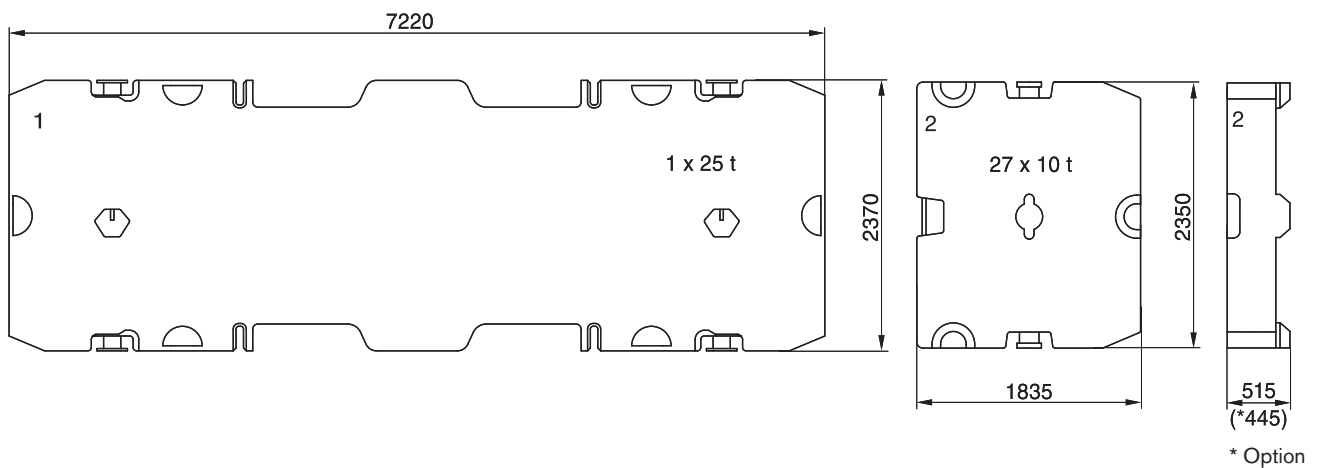
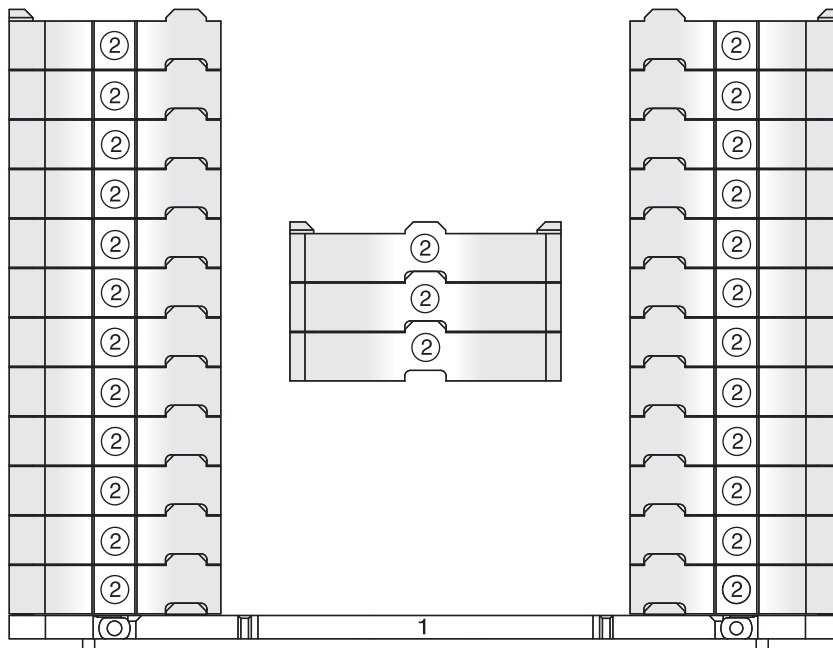



# SPECIFICATIONS

# CC 8800-1

## Technische Daten · Caractéristiques

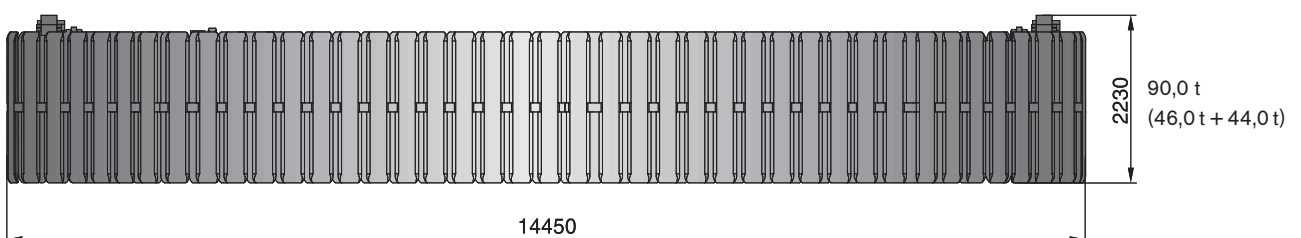
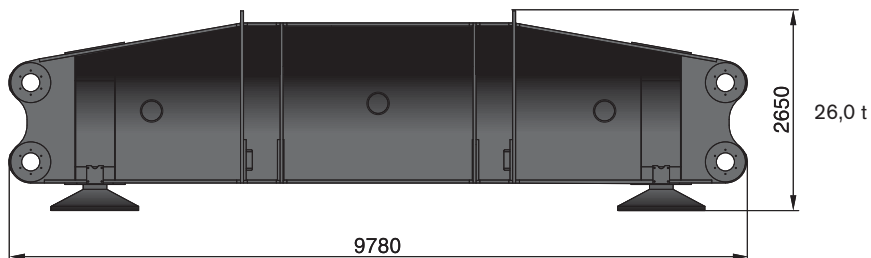
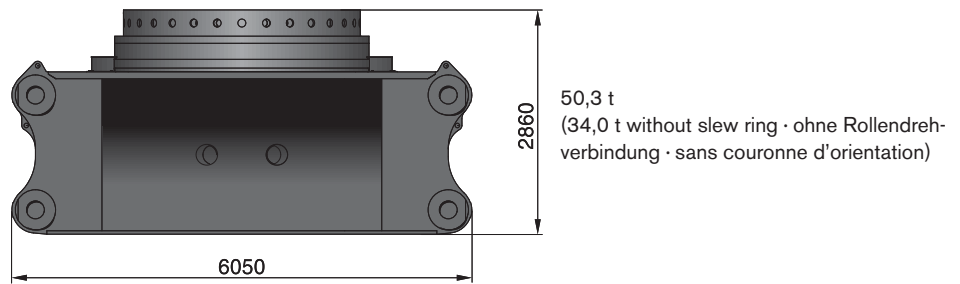
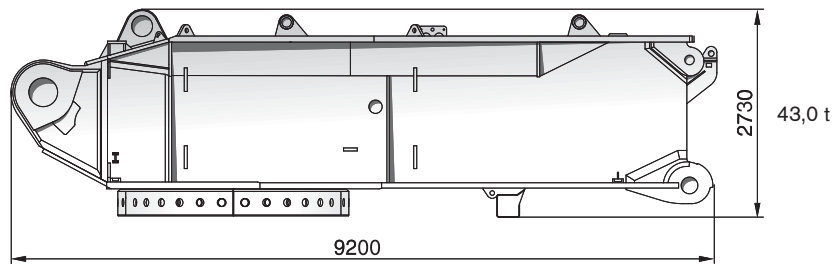
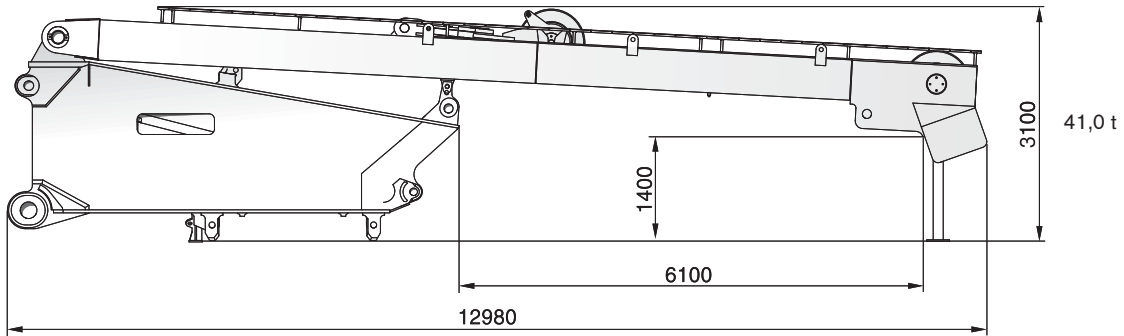
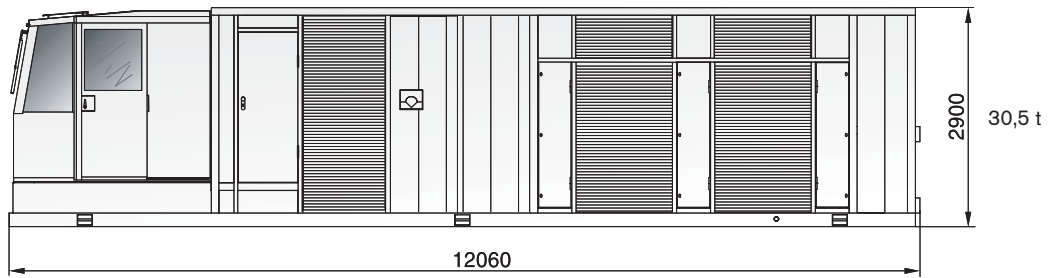

# BOOM COMBINATIONS

CC 8800-1

Ausleger-Kombinationen · Combinaisons de flèche

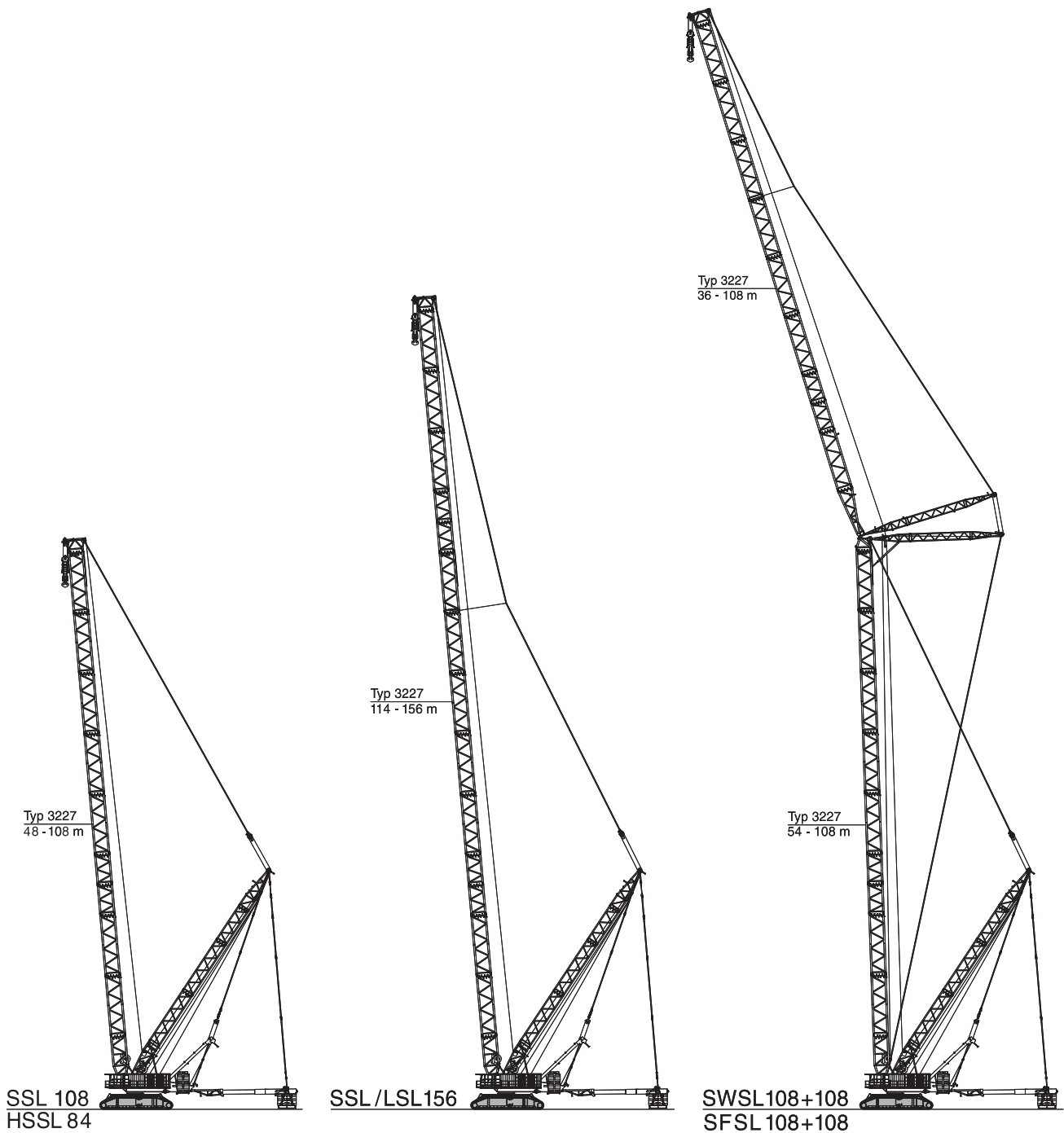

# BOOM COMBINATIONS

CC 8800-1

Ausleger-Kombinationen · Combinaisons de flèche

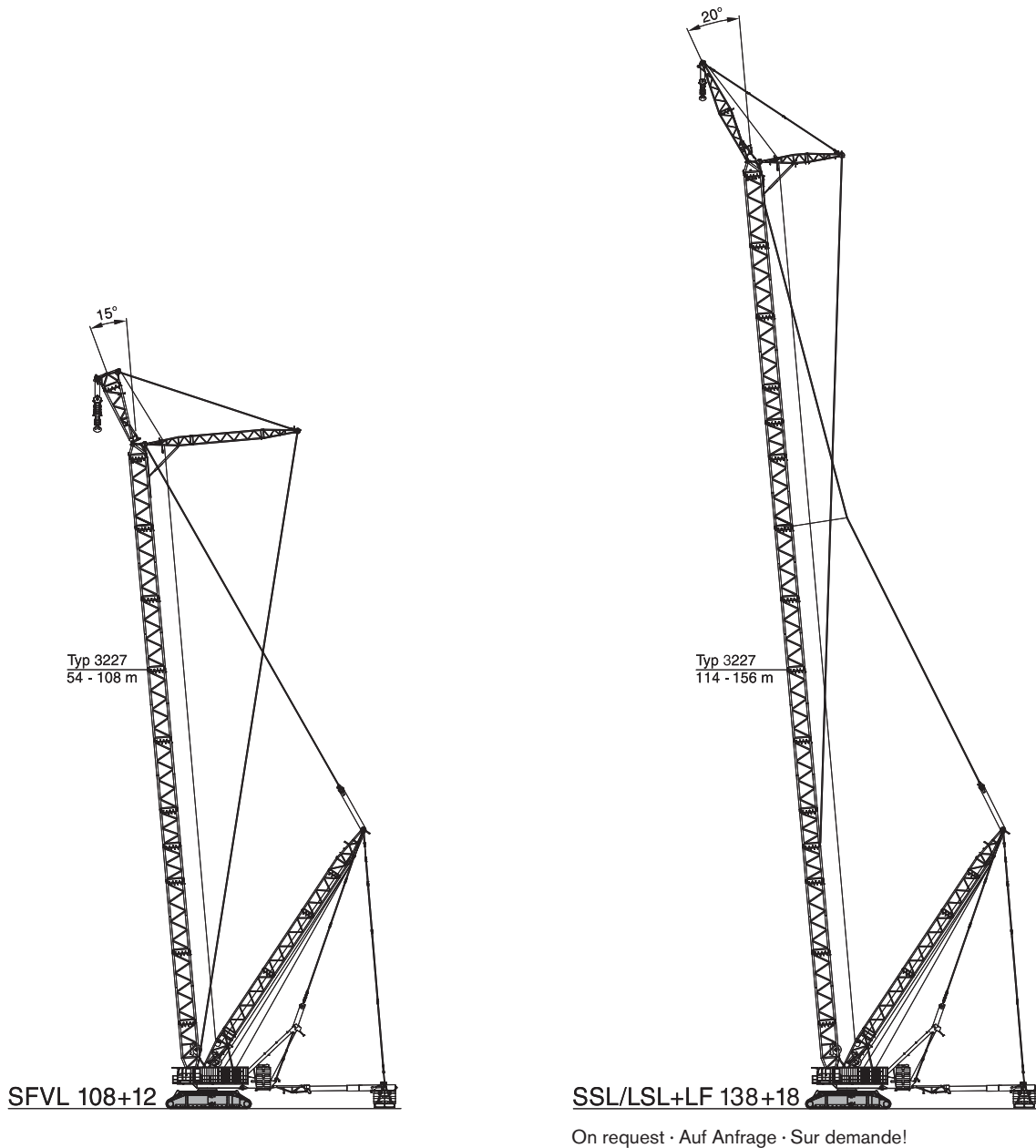

# SUPERLIFT CONFIGURATIONS

CC 8800-1

## Superlift-Konfigurationen · Combinaisons Superlift

Standard Superlift attachment · Serienmäßige Superlifteinrichtung · Superlift de série

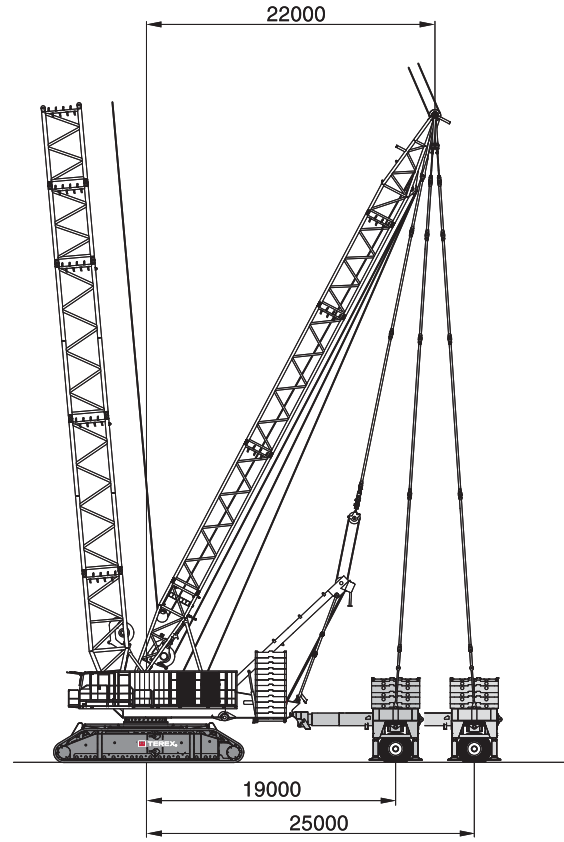
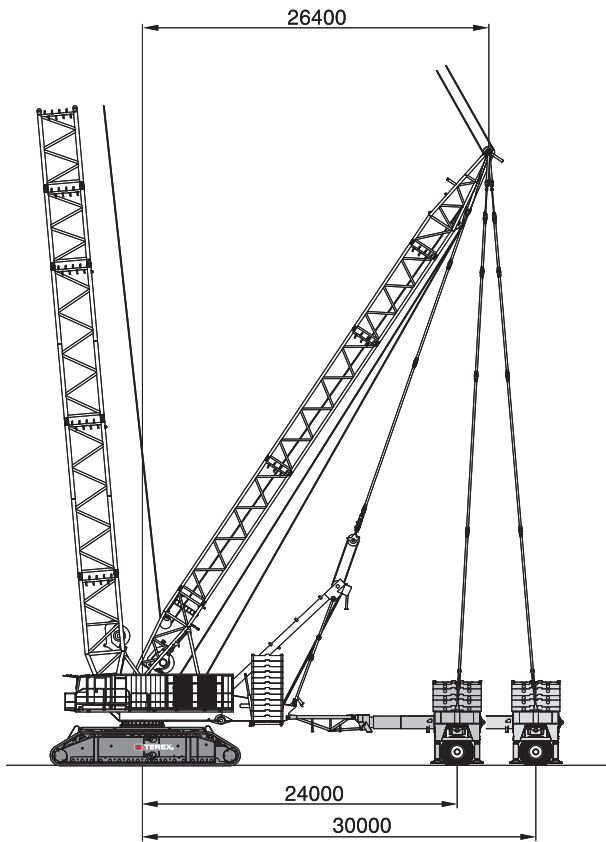

Variable Superlift attachment · Variable Superlifteinrichtung · Superlift variable

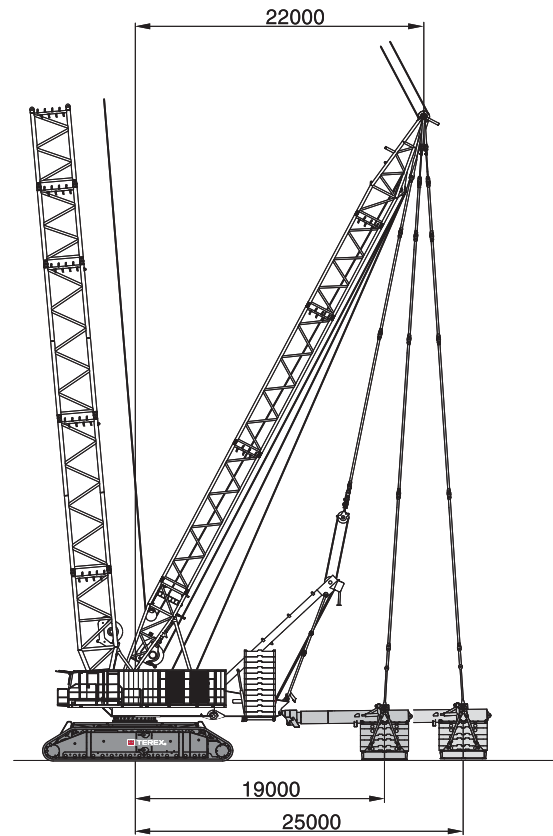
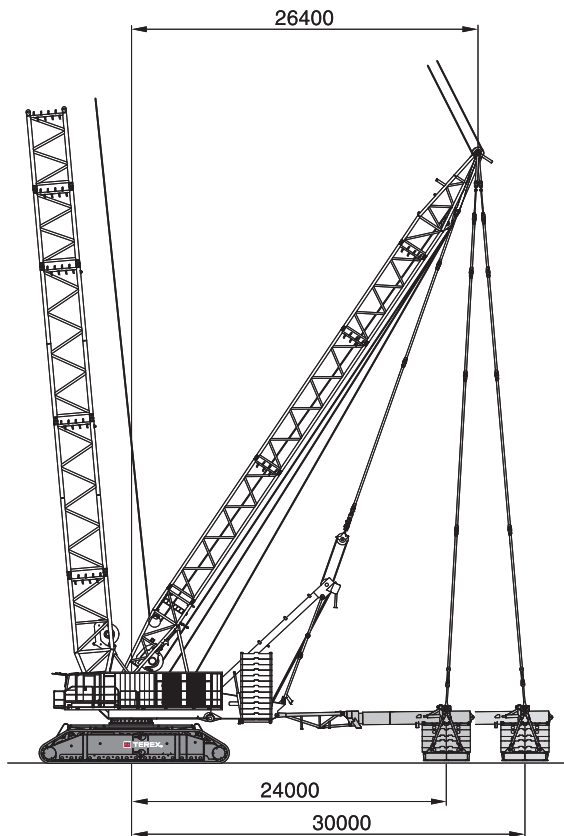

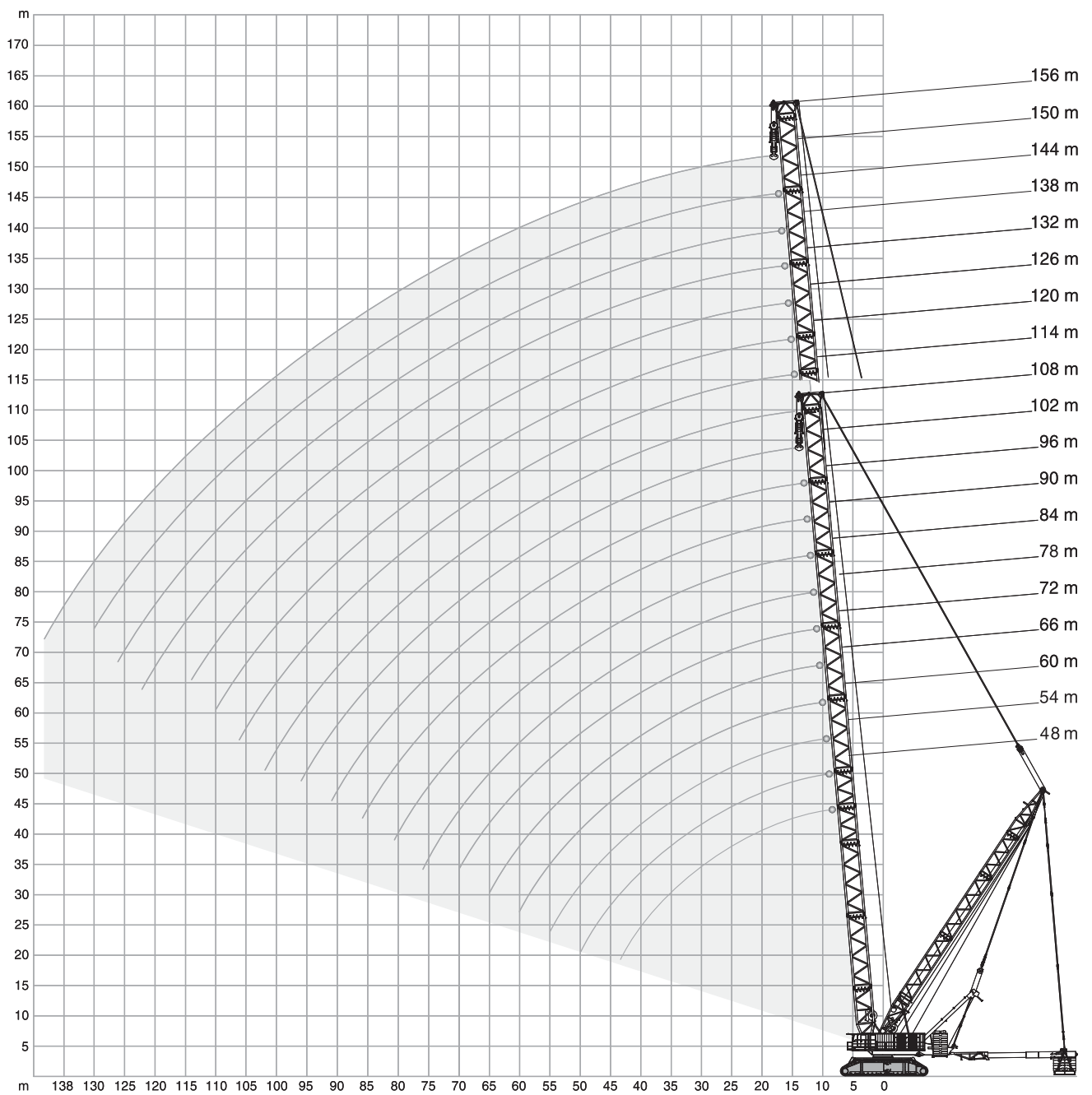

295 t + 60 t ZB		19-30 m		10,5 m		9.8 m/s		360°		ISO			
m	48 m		54 m		60 m		66 m		72 m		78 m		m
	0t-640t	0t-640t	0t	0t-640t	0t	0t-640t	0t	0t-640t	0t	0t-640t	0t	0t-640t	
	t	t	t	t	t	t	t	t	t	t	t	t	
10	1600,0	1600,0	799,0	1555,0	-	-	-	-	-	-	-	-	10
11	1585,5	1581,0	726,5	1553,0	684,0	1405,0	651,0	1238,0	-	-	-	-	11
12	1571,0	1562,0	654,0	1553,0	623,0	1405,0	594,0	1238,0	568,0	1098,0	-	-	12
14	1496,0	1487,0	551,0	1478,0	527,0	1383,0	505,0	1238,0	484,0	1098,0	-	-	14
16	1428,0	1419,0	474,0	1410,0	455,0	1383,0	436,0	1238,0	419,0	1098,0	-	-	16
18	1309,0	1309,0	414,0	1302,0	398,0	1290,0	383,0	1204,0	368,0	1098,0	-	-	18
20	1192,0	1192,0	367,0	1185,0	353,0	1178,0	339,0	1168,0	326,0	1060,0	-	-	20
22	1091,0	1085,0	323,0	1079,0	315,0	1073,0	303,0	1069,0	292,0	1038,0	-	-	22
24	991,0	992,0	282,0	986,0	278,0	980,0	273,0	976,0	263,0	973,0	-	-	24
26	912,0	913,0	249,0	907,0	245,0	901,0	242,0	897,0	239,0	893,0	-	-	26
28	830,0	845,0	222,0	839,0	218,0	833,0	215,0	829,0	213,0	825,0	-	-	28
30	751,0	785,0	199,0	779,0	195,0	774,0	192,0	770,0	190,0	766,0	-	-	30
34	620,0	687,0	163,0	682,0	159,0	676,0	156,0	672,0	154,0	668,0	-	-	34
38	538,0	580,0	136,0	604,0	132,0	599,0	129,0	594,0	126,0	591,0	-	-	38
42	449,0	491,0	116,0	532,0	111,0	536,0	108,0	532,0	104,0	528,0	-	-	42
46	-	436,0	99,5	457,0	94,0	484,0	90,0	479,0	87,0	476,0	-	-	46
50	-	367,0	86,0	392,0	80,0	424,0	76,0	435,0	72,0	431,0	-	-	50
54	-	-	75,0	353,0	68,5	369,0	64,0	394,0	60,5	393,0	-	-	54
55	-	-	73,0	339,0	66,2	356,2	61,6	382,0	58,0	385,0	-	-	55
58	-	-	-	-	59,5	324,0	54,5	346,0	50,5	361,0	-	-	58
60	-	-	-	-	55,5	312,0	50,6	324,0	46,4	342,5	-	-	60
62	-	-	-	-	-	-	46,8	302,0	42,3	324,0	-	-	62
65	-	-	-	-	-	-	41,9	278,0	37,1	294,7	-	-	65
66	-	-	-	-	-	-	-	-	35,4	285,0	-	-	66
70	-	-	-	-	-	-	-	-	29,8	249,0	-	-	70

m	84 m		90 m		96 m		102 m		108 m		m
	0t	0t-640t	0t	0t-640t	0t	0t-640t	0t	0t-640t	0t	0t-640t	
	t	t	t	t	t	t	t	t	t	t	
12	543,0	976,0	-	-	-	-	-	-	-	-	12
13	503,0	976,0	479,0	867,0	459,0	775,0	-	-	-	-	13
14	463,0	976,0	445,0	867,0	426,0	775,0	409,0	695,0	392,0	625,0	14
16	402,0	976,0	387,0	867,0	371,0	775,0	357,0	695,0	342,0	625,0	16
18	353,0	976,0	340,0	867,0	327,0	775,0	314,0	695,0	302,0	625,0	18
20	314,0	973,0	302,0	867,0	290,0	775,0	279,0	695,0	268,0	625,0	20
22	281,0	940,0	270,0	858,0	260,0	774,0	250,0	695,0	240,0	625,0	22
24	253,0	927,0	244,0	846,0	234,0	766,0	225,0	692,0	215,0	624,0	24
26	229,0	888,0	220,0	829,0	212,0	759,0	203,0	687,0	194,0	621,0	26
28	208,0	820,0	200,0	818,0	192,0	747,0	184,0	683,0	176,0	617,0	28
30	187,0	761,0	183,0	759,0	175,0	743,0	168,0	674,0	160,0	613,0	30
34	150,0	663,0	149,0	661,0	146,0	657,0	140,0	653,0	133,0	600,0	34
38	123,0	586,0	121,0	583,0	118,0	579,0	115,0	576,0	111,0	569,0	38
42	100,0	523,0	98,5	521,0	95,0	516,0	92,0	513,0	90,0	510,0	42
46	82,5	471,0	80,5	468,0	77,0	464,0	73,5	461,0	71,5	458,0	46
50	68,0	426,0	65,5	423,0	62,0	419,0	58,5	416,0	56,5	413,0	50
54	55,5	388,0	53,5	385,0	49,7	381,0	46,5	378,0	44,3	375,0	54
58	45,8	355,0	43,2	353,0	39,4	348,0	36,1	345,0	33,8	342,0	58
62	37,3	327,0	34,6	324,0	30,6	320,0	27,2	316,0	24,8	314,0	62
66	30,2	301,0	27,2	300,0	23,1	295,0	19,6	292,0	17,0	289,0	66
70	24,2	267,0	20,9	278,0	16,6	274,0	13,0	270,0	10,3	267,0	70
72	21,7	251,5	18,2	265,0	13,8	264,0	10,1	260,0	-	257,0	72
74	19,2	236,0	15,5	252,0	11,1	254,0	-	250,0	-	247,0	74
76	17,0	220,0	13,2	238,0	-	244,0	-	241,5	-	238,5	76
78	-	-	11,0	224,0	-	234,0	-	233,0	-	230,0	78
79	-	-	10,0	217,0	-	227,7	-	229,2	-	226,0	79
81	-	-	-	203,0	-	215,2	-	221,7	-	218,0	81
82	-	-	-	-	-	209,0	-	218,0	-	214,0	82
86	-	-	-	-	-	185,0	-	196,0	-	200,0	86
90	-	-	-	-	-	-	-	175,0	-	183,0	90
91	-	-	-	-	-	-	-	169,0	-	178,2	91
94	-	-	-	-	-	-	-	-	-	164,0	94
96	-	-	-	-	-	-	-	-	-	154,0	96

295 t + 60 t ZB												19-30 m		10,5 m		9.8 m/s		360°		ISO	
		114 m		120 m		126 m		132 m		138 m											
		0 t	0t-640t	0 t	0t-640t	0 t	0t-640t	0 t	0t-640t	0 t	0t-640t										
m	t	t	t	t	t	t	t	t	t	t	t	t	m								
16	333,0	562,0	321,0	506,0	311,0	457,0	300,0	410,0	-	-	-	-	16								
18	295,0	562,0	284,0	506,0	276,0	457,0	266,0	410,0	258,0	369,0	369,0	369,0	18								
20	263,0	562,0	252,0	506,0	246,0	457,0	237,0	410,0	230,0	369,0	369,0	369,0	20								
22	235,0	562,0	226,0	506,0	220,0	456,0	212,0	410,0	206,0	369,0	369,0	369,0	22								
24	212,0	562,0	203,0	506,0	198,0	456,0	191,0	410,0	185,0	369,0	369,0	369,0	24								
26	191,0	561,0	184,0	506,0	179,0	456,0	173,0	410,0	167,0	369,0	369,0	369,0	26								
28	174,0	559,0	166,0	504,0	162,0	453,0	156,0	410,0	151,0	369,0	369,0	369,0	28								
30	158,0	556,0	151,0	501,0	147,0	447,0	142,0	410,0	137,0	369,0	369,0	369,0	30								
34	131,0	552,0	125,0	495,0	122,0	435,0	117,0	409,0	113,0	368,0	368,0	368,0	34								
38	110,0	529,0	104,0	489,0	102,0	423,0	97,5	408,0	94,0	367,0	367,0	367,0	38								
42	91,0	504,0	87,0	458,0	85,0	405,0	80,5	403,0	77,5	366,0	366,0	366,0	42								
46	72,5	459,0	70,5	438,0	70,5	388,0	66,5	388,0	63,5	355,0	355,0	355,0	46								
50	57,5	415,0	55,0	412,0	56,0	370,0	54,5	365,0	52,0	344,0	344,0	344,0	50								
54	45,2	376,0	42,8	374,0	43,5	352,0	42,4	352,0	40,8	323,0	323,0	323,0	54								
58	34,6	343,0	32,1	341,0	32,8	334,0	31,7	339,0	30,0	313,0	313,0	313,0	58								
62	25,6	315,0	23,0	312,0	23,7	312,0	22,5	311,0	20,8	303,0	303,0	303,0	62								
66	17,8	290,0	15,2	287,0	15,8	287,0	14,6	286,0	12,8	284,0	284,0	284,0	66								
70	11,1	268,0	-	265,0	-	265,0	-	264,0	-	262,0	262,0	262,0	70								
74	-	248,0	-	245,0	-	245,0	-	244,0	-	242,0	242,0	242,0	74								
78	-	231,0	-	228,0	-	228,0	-	226,0	-	224,0	224,0	224,0	78								
82	-	215,0	-	212,0	-	212,0	-	210,0	-	208,0	208,0	208,0	82								
86	-	201,0	-	198,0	-	198,0	-	196,0	-	194,0	194,0	194,0	86								
90	-	188,0	-	185,0	-	185,0	-	183,0	-	181,0	181,0	181,0	90								
94	-	175,0	-	173,0	-	173,0	-	171,0	-	169,0	169,0	169,0	94								
98	-	158,0	-	163,0	-	162,0	-	160,0	-	158,0	158,0	158,0	98								
102	-	141,0	-	147,0	-	153,0	-	151,0	-	148,0	148,0	148,0	102								
106	-	-	-	132,0	-	140,0	-	141,0	-	139,0	139,0	139,0	106								
110	-	-	-	-	-	126,0	-	131,0	-	131,0	131,0	131,0	110								
114	-	-	-	-	-	-	-	119,0	-	122,0	122,0	122,0	114								
118	-	-	-	-	-	-	-	-	-	111,0	111,0	111,0	118								
122	-	-	-	-	-	-	-	-	-	99,5	99,5	99,5	122								

295 t + 60 t ZB		19-30 m		10,5 m		9.8 m/s		360°		ISO	
		144 m		150 m		156 m					
		0 t		0t-640t		0 t		0t-640t			
m	t	t	t	t	t	t	t	m	t	t	t
18	248,0	331,0	243,0	299,0	234,0	268,0	18	18			
20	221,0	331,0	217,0	299,0	209,0	268,0	20	20			
22	198,0	331,0	195,0	299,0	187,0	268,0	22	22			
24	179,0	331,0	175,0	299,0	169,0	268,0	24	24			
26	161,0	331,0	158,0	299,0	152,0	267,0	26	26			
28	145,0	331,0	143,0	299,0	137,0	267,0	28	28			
30	132,0	331,0	130,0	299,0	124,0	267,0	30	30			
34	108,0	331,0	107,0	298,0	102,0	265,0	34	34			
38	89,0	330,0	88,5	296,0	83,5	262,0	38	38			
42	73,0	329,0	72,5	294,0	68,0	259,0	42	42			
46	59,5	323,0	59,0	291,0	55,0	256,0	46	46			
50	48,0	313,0	47,9	283,0	44,0	251,0	50	50			
54	37,8	304,0	38,0	276,0	34,1	246,0	54	54			
58	29,0	290,0	29,2	269,0	25,4	240,0	58	58			
62	19,7	279,0	20,5	262,0	17,8	235,0	62	62			
66	11,7	270,0	12,5	250,0	11,0	229,0	66	66			
70	-	260,0	-	244,0	-	221,0	70	70			
74	-	240,0	-	237,0	-	215,0	74	74			
78	-	223,0	-	223,0	-	210,0	78	78			
82	-	207,0	-	207,0	-	205,0	82	82			
86	-	193,0	-	193,0	-	192,0	86	86			
90	-	179,0	-	180,0	-	179,0	90	90			
94	-	168,0	-	168,0	-	167,0	94	94			
98	-	157,0	-	157,0	-	156,0	98	98			
102	-	147,0	-	147,0	-	146,0	102	102			
106	-	137,0	-	138,0	-	136,0	106	106			
110	-	129,0	-	129,0	-	128,0	110	110			
114	-	121,0	-	122,0	-	120,0	114	114			
118	-	114,0	-	114,0	-	112,0	118	118			
122	-	103,0	-	108,0	-	106,0	122	122			
126	-	93,0	-	98,0	-	99,5	126	126			
130	-	-	-	88,5	-	90,5	130	130			
134	-	-	-	-	-	81,5	134	134			
138	-	-	-	-	-	72,5	138	138			



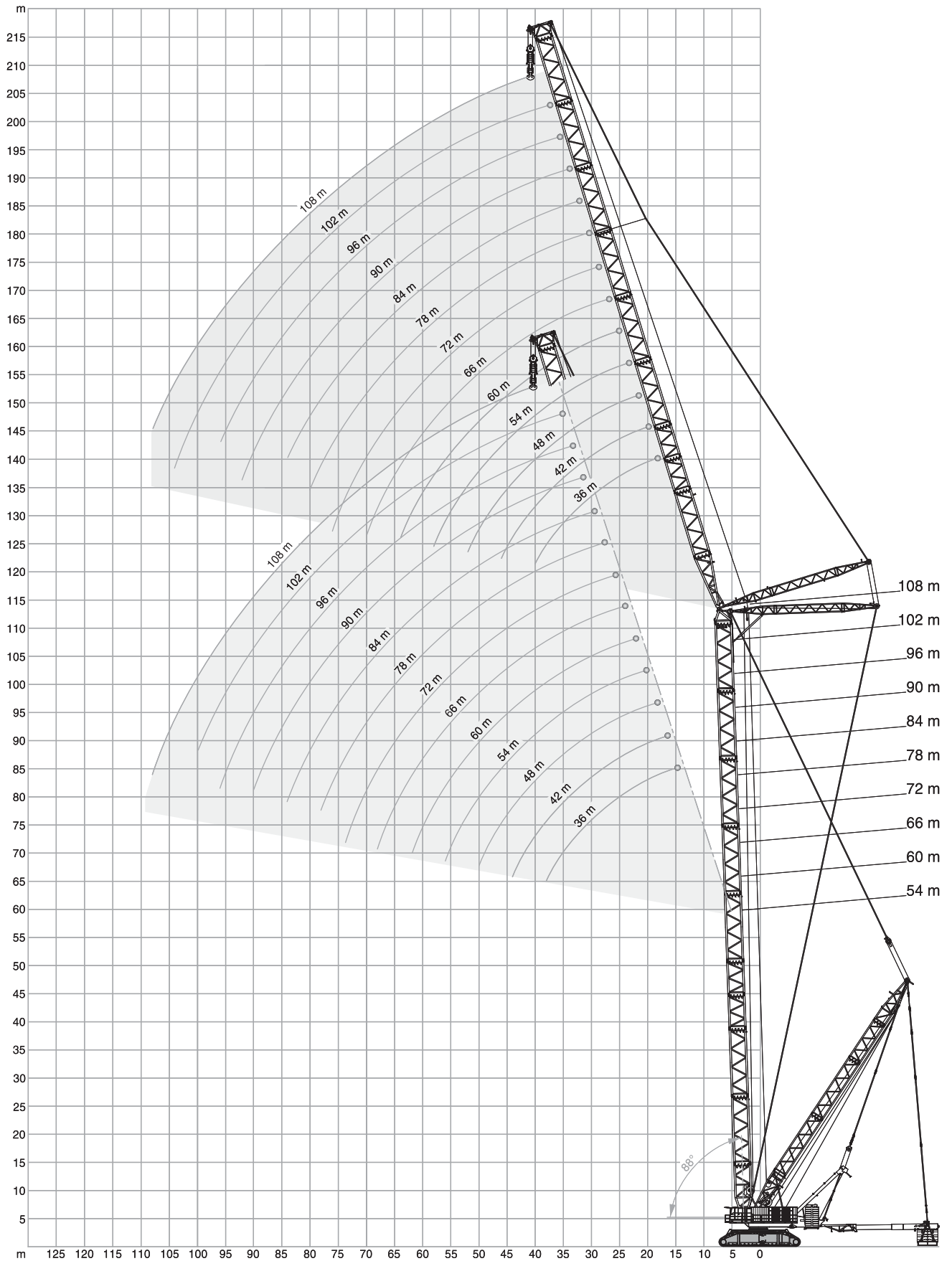

295 t + 60 t ZB 19-30 m 10,5 m 9.8 m/s 360° ISO

**54 m + 36 m**

m	SWSL							SFSL
	0 t		0 t-640 t					
	85°	85°	75°	65°	55°	45°	t	
18	-	629,0*	-	-	-	-	-	
20	-	614,0*	-	-	-	-	-	
22	-	594,0*	-	-	-	-	-	
24	291,0	653,0	-	-	-	-	640,0	
26	268,0	639,0	-	-	-	-	640,0	
28	249,0	603,0	-	-	-	-	640,0	
30	231,0	543,0	-	-	-	-	640,0	
34	197,0	450,0	-	-	-	-	632,0	
37	175,5	398,5	613,0	-	-	-	611,5	
38	169,0	383,0	582,0	-	-	-	598,0	
42	146,0	332,0	478,0	-	-	-	532,0	
46	-	-	403,0	-	-	-	477,0	
50	-	-	348,0	-	-	-	431,0	
51	-	-	336,5	424,0	-	-	420,5	
52	-	-	325,0	414,0	-	-	410,0	
54	-	-	-	397,0	-	-	389,0	
58	-	-	-	360,0	-	-	345,0	
61	-	-	-	325,0	-	-	315,7	
62	-	-	-	-	-	-	306,0	
64	-	-	-	-	291,0	-	288,5	
66	-	-	-	-	280,0	-	271,0	
69	-	-	-	-	265,0	-	247,7	
70	-	-	-	-	-	-	240,0	
74	-	-	-	-	-	222,0	220,0	
76	-	-	-	-	-	215,0	208,0	
78	-	-	-	-	-	-	196,0	
82	-	-	-	-	-	-	170,0	

**54 m + 48 m**

m	t	t	t	t	t	t	t
22	-	496,0*	-	-	-	-	-
24	-	484,0*	-	-	-	-	-
26	-	471,0*	-	-	-	-	-
28	233,0	516,0	-	-	-	-	504,0
30	217,0	508,0	-	-	-	-	504,0
34	190,0	484,0	-	-	-	-	504,0
38	165,0	411,0	-	-	-	-	504,0
42	143,0	356,0	-	-	-	-	496,0
43	138,5	344,5	490,0	-	-	-	488,0
46	125,0	313,0	434,0	-	-	-	463,0
50	111,0	278,0	373,0	-	-	-	431,0
54	99,0	244,0	326,0	-	-	-	393,0
58	-	-	289,0	-	-	-	358,0
59	-	-	281,0	354,0	-	-	349,5
62	-	-	259,0	333,0	-	-	324,0
66	-	-	-	297,0	-	-	291,0
70	-	-	-	265,0	-	-	260,0
72	-	-	-	252,0	-	-	246,5
73	-	-	-	-	241,0	-	239,7
74	-	-	-	-	237,0	-	233,0
78	-	-	-	-	222,0	-	208,0
80	-	-	-	-	215,0	-	197,5
82	-	-	-	-	-	-	190,0
85	-	-	-	-	-	181,0	177,2
86	-	-	-	-	-	178,0	173,0
87	-	-	-	-	-	176,0	167,7
90	-	-	-	-	-	-	152,0
94	-	-	-	-	-	-	132,0

**54 m + 60 m**

m	SWSL							SFSL
	0 t		0 t-640 t					
	85°	85°	75°	65°	55°	45°	t	
26	-	394,0*	-	-	-	-	-	
28	-	386,0*	-	-	-	-	-	
30	-	378,0*	-	-	-	-	-	
32	191,0	411,0	-	-	-	-	401,0	
34	179,0	406,0	-	-	-	-	401,0	
38	158,0	396,0	-	-	-	-	401,0	
42	141,0	367,0	-	-	-	-	401,0	
46	124,0	322,0	-	-	-	-	401,0	
49	113,5	293,5	400,0	-	-	-	391,0	
50	110,0	285,0	385,0	-	-	-	387,0	
54	97,5	255,0	336,0	-	-	-	363,0	
58	87,5	229,0	297,0	-	-	-	340,0	
62	78,5	208,0	264,0	-	-	-	319,0	
64	75,0	197,0	250,0	-	-	-	310,0	
66	-	-	238,0	-	-	-	301,0	
67	-	-	232,0	296,0	-	-	295,2	
70	-	-	215,0	271,0	-	-	278,0	
74	-	-	195,0	243,0	-	-	251,0	
78	-	-	-	220,0	-	-	227,0	
82	-	-	-	200,0	205,0	-	204,0	
86	-	-	-	-	193,0	-	184,0	
90	-	-	-	-	182,0	-	167,0	
92	-	-	-	-	176,0	-	161,0	
94	-	-	-	-	-	-	155,0	
95	-	-	-	-	-	153,0	150,7	
98	-	-	-	-	-	146,0	138,0	
99	-	-	-	-	-	144,0	134,0	
102	-	-	-	-	-	-	122,0	
106	-	-	-	-	-	-	105,0	

**54 m + 72 m**

m	t	t	t	t	t	t	t
30	-	315,0*	-	-	-	-	-
34	-	306,0*	-	-	-	-	-
36	157,0	328,0	-	-	-	-	321,0
38	148,0	325,0	-	-	-	-	321,0
42	132,0	320,0	-	-	-	-	321,0
46	118,0	314,0	-	-	-	-	321,0
50	106,0	283,0	-	-	-	-	321,0
54	95,0	253,0	-	-	-	-	315,0
56	89,5	240,0	314,0	-	-	-	309,5
58	84,5	227,0	295,0	-	-	-	304,0
62	75,5	206,0	263,0	-	-	-	286,0
66	68,0	187,0	236,0	-	-	-	269,0
70	61,0	171,0	213,0	-	-	-	253,0
74	55,0	157,0	193,0	241,0	-	-	239,0
76	52,0	146,0	185,0	229,0	-	-	233,0
78	-	-	176,0	218,0	-	-	227,0
82	-	-	162,0	198,0	-	-	215,0
86	-	-	149,0	180,0	-	-	196,0
90	-	-	-	165,0	-	-	178,0
91	-	-	-	161,5	174,0	-	173,5
94	-	-	-	152,0	166,0	-	160,0
98	-	-	-	-	157,0	-	145,0
102	-	-	-	-	148,0	-	136,0
105	-	-	-	-	-	127,0	126,2
106	-	-	-	-	-	125,0	123,0
110	-	-	-	-	-	118,0	109,0
114	-	-	-	-	-	-	95,5

\* Main boom angle 88° · Hauptauslegerwinkel 88° · Jarret de flèche principale 88°

see page 19 · siehe Seite 19 · voir page 19

295 t + 60 t ZB		19-30 m		10,5 m		9.8 m/s		360°		ISO																																																																																																																																																																																																																																																																																																																																																																																																																																																	
54 m + 84 m						54 m + 96 m																																																																																																																																																																																																																																																																																																																																																																																																																																																					
<table border="1"> <thead> <tr> <th colspan="11">SWSL</th> <th>SFSL</th> </tr> <tr> <th colspan="12">0 t - 640 t</th> </tr> <tr> <th></th> <th>85°</th> <th>85°</th> <th>75°</th> <th>65°</th> <th>55°</th> <th>45°</th> <th></th> <th></th> <th></th> <th></th> <th></th> </tr> <tr> <th>m</th> <th>t</th> <th>t</th> <th>t</th> <th>t</th> <th>t</th> <th>t</th> <th>t</th> <th>t</th> <th>t</th> <th>t</th> <th>t</th> </tr> </thead> <tbody> <tr><td>32</td><td>-</td><td>254,0*</td><td>-</td><td>-</td><td>-</td><td>-</td><td>-</td><td>-</td><td>-</td><td>-</td><td>-</td></tr> <tr><td>34</td><td>-</td><td>253,0*</td><td>-</td><td>-</td><td>-</td><td>-</td><td>-</td><td>-</td><td>-</td><td>-</td><td>-</td></tr> <tr><td>38</td><td>-</td><td>247,0*</td><td>-</td><td>-</td><td>-</td><td>-</td><td>-</td><td>-</td><td>-</td><td>-</td><td>-</td></tr> <tr><td>40</td><td>128,0</td><td>261,0</td><td>-</td><td>-</td><td>-</td><td>-</td><td>-</td><td>-</td><td>-</td><td>258,0</td><td>-</td></tr> <tr><td>42</td><td>120,0</td><td>260,0</td><td>-</td><td>-</td><td>-</td><td>-</td><td>-</td><td>-</td><td>-</td><td>258,0</td><td>-</td></tr> <tr><td>46</td><td>107,0</td><td>256,0</td><td>-</td><td>-</td><td>-</td><td>-</td><td>-</td><td>-</td><td>-</td><td>258,0</td><td>-</td></tr> <tr><td>50</td><td>96,0</td><td>252,0</td><td>-</td><td>-</td><td>-</td><td>-</td><td>-</td><td>-</td><td>-</td><td>258,0</td><td>-</td></tr> <tr><td>54</td><td>86,0</td><td>247,0</td><td>-</td><td>-</td><td>-</td><td>-</td><td>-</td><td>-</td><td>-</td><td>258,0</td><td>-</td></tr> <tr><td>58</td><td>77,5</td><td>221,0</td><td>-</td><td>-</td><td>-</td><td>-</td><td>-</td><td>-</td><td>-</td><td>256,0</td><td>-</td></tr> <tr><td>62</td><td>69,5</td><td>199,0</td><td>254,0</td><td>-</td><td>-</td><td>-</td><td>-</td><td>-</td><td>-</td><td>248,0</td><td>-</td></tr> <tr><td>66</td><td>61,0</td><td>181,0</td><td>229,0</td><td>-</td><td>-</td><td>-</td><td>-</td><td>-</td><td>-</td><td>240,0</td><td>-</td></tr> <tr><td>70</td><td>54,0</td><td>165,0</td><td>207,0</td><td>-</td><td>-</td><td>-</td><td>-</td><td>-</td><td>-</td><td>226,0</td><td>-</td></tr> <tr><td>74</td><td>48,1</td><td>151,0</td><td>187,0</td><td>-</td><td>-</td><td>-</td><td>-</td><td>-</td><td>-</td><td>212,0</td><td>-</td></tr> <tr><td>78</td><td>42,6</td><td>138,0</td><td>170,0</td><td>-</td><td>-</td><td>-</td><td>-</td><td>-</td><td>-</td><td>200,0</td><td>-</td></tr> <tr><td>82</td><td>37,8</td><td>127,0</td><td>155,0</td><td>191,0</td><td>-</td><td>-</td><td>-</td><td>-</td><td>-</td><td>190,0</td><td>-</td></tr> <tr><td>86</td><td>33,6</td><td>115,5</td><td>142,0</td><td>174,0</td><td>-</td><td>-</td><td>-</td><td>-</td><td>-</td><td>180,0</td><td>-</td></tr> <tr><td>88</td><td>31,7</td><td>109,0</td><td>136,0</td><td>166,0</td><td>-</td><td>-</td><td>-</td><td>-</td><td>-</td><td>175,5</td><td>-</td></tr> <tr><td>90</td><td>-</td><td>-</td><td>131,0</td><td>159,0</td><td>-</td><td>-</td><td>-</td><td>-</td><td>-</td><td>171,0</td><td>-</td></tr> <tr><td>94</td><td>-</td><td>-</td><td>121,0</td><td>145,0</td><td>-</td><td>-</td><td>-</td><td>-</td><td>-</td><td>162,0</td><td>-</td></tr> <tr><td>96</td><td>-</td><td>-</td><td>116,0</td><td>139,0</td><td>-</td><td>-</td><td>-</td><td>-</td><td>-</td><td>156,0</td><td>-</td></tr> <tr><td>98</td><td>-</td><td>-</td><td>-</td><td>134,0</td><td>-</td><td>-</td><td>-</td><td>-</td><td>-</td><td>150,0</td><td>-</td></tr> <tr><td>100</td><td>-</td><td>-</td><td>-</td><td>128,0</td><td>143,0</td><td>-</td><td>-</td><td>-</td><td>-</td><td>143,0</td><td>-</td></tr> <tr><td>102</td><td>-</td><td>-</td><td>-</td><td>123,0</td><td>139,0</td><td>-</td><td>-</td><td>-</td><td>-</td><td>136,0</td><td>-</td></tr> <tr><td>106</td><td>-</td><td>-</td><td>-</td><td>114,0</td><td>131,0</td><td>-</td><td>-</td><td>-</td><td>-</td><td>123,0</td><td>-</td></tr> <tr><td>110</td><td>-</td><td>-</td><td>-</td><td>-</td><td>124,0</td><td>-</td><td>-</td><td>-</td><td>-</td><td>115,0</td><td>-</td></tr> <tr><td>114</td><td>-</td><td>-</td><td>-</td><td>-</td><td>114,0</td><td>-</td><td>-</td><td>-</td><td>-</td><td>105,0</td><td>-</td></tr> <tr><td>116</td><td>-</td><td>-</td><td>-</td><td>-</td><td>-</td><td>100,0</td><td>-</td><td>-</td><td>-</td><td>99,0</td><td>-</td></tr> <tr><td>118</td><td>-</td><td>-</td><td>-</td><td>-</td><td>-</td><td>97,5</td><td>93,0</td><td>-</td><td>-</td><td>93,0</td><td>-</td></tr> <tr><td>122</td><td>-</td><td>-</td><td>-</td><td>-</td><td>-</td><td>92,5</td><td>81,5</td><td>-</td><td>-</td><td>81,5</td><td>-</td></tr> <tr><td>126</td><td>-</td><td>-</td><td>-</td><td>-</td><td>-</td><td>-</td><td>70,0</td><td>-</td><td>-</td><td>70,0</td><td>-</td></tr> </tbody> </table>												SWSL											SFSL	0 t - 640 t													85°	85°	75°	65°	55°	45°						m	t	t	t	t	t	t	t	t	t	t	t	32	-	254,0*	-	-	-	-	-	-	-	-	-	34	-	253,0*	-	-	-	-	-	-	-	-	-	38	-	247,0*	-	-	-	-	-	-	-	-	-	40	128,0	261,0	-	-	-	-	-	-	-	258,0	-	42	120,0	260,0	-	-	-	-	-	-	-	258,0	-	46	107,0	256,0	-	-	-	-	-	-	-	258,0	-	50	96,0	252,0	-	-	-	-	-	-	-	258,0	-	54	86,0	247,0	-	-	-	-	-	-	-	258,0	-	58	77,5	221,0	-	-	-	-	-	-	-	256,0	-	62	69,5	199,0	254,0	-	-	-	-	-	-	248,0	-	66	61,0	181,0	229,0	-	-	-	-	-	-	240,0	-	70	54,0	165,0	207,0	-	-	-	-	-	-	226,0	-	74	48,1	151,0	187,0	-	-	-	-	-	-	212,0	-	78	42,6	138,0	170,0	-	-	-	-	-	-	200,0	-	82	37,8	127,0	155,0	191,0	-	-	-	-	-	190,0	-	86	33,6	115,5	142,0	174,0	-	-	-	-	-	180,0	-	88	31,7	109,0	136,0	166,0	-	-	-	-	-	175,5	-	90	-	-	131,0	159,0	-	-	-	-	-	171,0	-	94	-	-	121,0	145,0	-	-	-	-	-	162,0	-	96	-	-	116,0	139,0	-	-	-	-	-	156,0	-	98	-	-	-	134,0	-	-	-	-	-	150,0	-	100	-	-	-	128,0	143,0	-	-	-	-	143,0	-	102	-	-	-	123,0	139,0	-	-	-	-	136,0	-	106	-	-	-	114,0	131,0	-	-	-	-	123,0	-	110	-	-	-	-	124,0	-	-	-	-	115,0	-	114	-	-	-	-	114,0	-	-	-	-	105,0	-	116	-	-	-	-	-	100,0	-	-	-	99,0	-	118	-	-	-	-	-	97,5	93,0	-	-	93,0	-	122	-	-	-	-	-	92,5	81,5	-	-	81,5	-	126	-	-	-	-	-	-	70,0	-	-	70,0	-																								
SWSL											SFSL																																																																																																																																																																																																																																																																																																																																																																																																																																																
0 t - 640 t																																																																																																																																																																																																																																																																																																																																																																																																																																																											
	85°	85°	75°	65°	55°	45°																																																																																																																																																																																																																																																																																																																																																																																																																																																					
m	t	t	t	t	t	t	t	t	t	t	t																																																																																																																																																																																																																																																																																																																																																																																																																																																
32	-	254,0*	-	-	-	-	-	-	-	-	-																																																																																																																																																																																																																																																																																																																																																																																																																																																
34	-	253,0*	-	-	-	-	-	-	-	-	-																																																																																																																																																																																																																																																																																																																																																																																																																																																
38	-	247,0*	-	-	-	-	-	-	-	-	-																																																																																																																																																																																																																																																																																																																																																																																																																																																
40	128,0	261,0	-	-	-	-	-	-	-	258,0	-																																																																																																																																																																																																																																																																																																																																																																																																																																																
42	120,0	260,0	-	-	-	-	-	-	-	258,0	-																																																																																																																																																																																																																																																																																																																																																																																																																																																
46	107,0	256,0	-	-	-	-	-	-	-	258,0	-																																																																																																																																																																																																																																																																																																																																																																																																																																																
50	96,0	252,0	-	-	-	-	-	-	-	258,0	-																																																																																																																																																																																																																																																																																																																																																																																																																																																
54	86,0	247,0	-	-	-	-	-	-	-	258,0	-																																																																																																																																																																																																																																																																																																																																																																																																																																																
58	77,5	221,0	-	-	-	-	-	-	-	256,0	-																																																																																																																																																																																																																																																																																																																																																																																																																																																
62	69,5	199,0	254,0	-	-	-	-	-	-	248,0	-																																																																																																																																																																																																																																																																																																																																																																																																																																																
66	61,0	181,0	229,0	-	-	-	-	-	-	240,0	-																																																																																																																																																																																																																																																																																																																																																																																																																																																
70	54,0	165,0	207,0	-	-	-	-	-	-	226,0	-																																																																																																																																																																																																																																																																																																																																																																																																																																																
74	48,1	151,0	187,0	-	-	-	-	-	-	212,0	-																																																																																																																																																																																																																																																																																																																																																																																																																																																
78	42,6	138,0	170,0	-	-	-	-	-	-	200,0	-																																																																																																																																																																																																																																																																																																																																																																																																																																																
82	37,8	127,0	155,0	191,0	-	-	-	-	-	190,0	-																																																																																																																																																																																																																																																																																																																																																																																																																																																
86	33,6	115,5	142,0	174,0	-	-	-	-	-	180,0	-																																																																																																																																																																																																																																																																																																																																																																																																																																																
88	31,7	109,0	136,0	166,0	-	-	-	-	-	175,5	-																																																																																																																																																																																																																																																																																																																																																																																																																																																
90	-	-	131,0	159,0	-	-	-	-	-	171,0	-																																																																																																																																																																																																																																																																																																																																																																																																																																																
94	-	-	121,0	145,0	-	-	-	-	-	162,0	-																																																																																																																																																																																																																																																																																																																																																																																																																																																
96	-	-	116,0	139,0	-	-	-	-	-	156,0	-																																																																																																																																																																																																																																																																																																																																																																																																																																																
98	-	-	-	134,0	-	-	-	-	-	150,0	-																																																																																																																																																																																																																																																																																																																																																																																																																																																
100	-	-	-	128,0	143,0	-	-	-	-	143,0	-																																																																																																																																																																																																																																																																																																																																																																																																																																																
102	-	-	-	123,0	139,0	-	-	-	-	136,0	-																																																																																																																																																																																																																																																																																																																																																																																																																																																
106	-	-	-	114,0	131,0	-	-	-	-	123,0	-																																																																																																																																																																																																																																																																																																																																																																																																																																																
110	-	-	-	-	124,0	-	-	-	-	115,0	-																																																																																																																																																																																																																																																																																																																																																																																																																																																
114	-	-	-	-	114,0	-	-	-	-	105,0	-																																																																																																																																																																																																																																																																																																																																																																																																																																																
116	-	-	-	-	-	100,0	-	-	-	99,0	-																																																																																																																																																																																																																																																																																																																																																																																																																																																
118	-	-	-	-	-	97,5	93,0	-	-	93,0	-																																																																																																																																																																																																																																																																																																																																																																																																																																																
122	-	-	-	-	-	92,5	81,5	-	-	81,5	-																																																																																																																																																																																																																																																																																																																																																																																																																																																
126	-	-	-	-	-	-	70,0	-	-	70,0	-																																																																																																																																																																																																																																																																																																																																																																																																																																																
<table border="1"> <thead> <tr> <th colspan="11">SWSL</th> <th>SFSL</th> </tr> <tr> <th colspan="12">0 t - 640 t</th> </tr> <tr> <th></th> <th>85°</th> <th>85°</th> <th>75°</th> <th>65°</th> <th>55°</th> <th>45°</th> <th></th> <th></th> <th></th> <th></th> <th></th> </tr> <tr> <th>m</th> <th>t</th> <th>t</th> <th>t</th> <th>t</th> <th>t</th> <th>t</th> <th>t</th> <th>t</th> <th>t</th> <th>t</th> <th>t</th> </tr> </thead> <tbody> <tr><td>36</td><td>-</td><td>201,0*</td><td>-</td><td>-</td><td>-</td><td>-</td><td>-</td><td>-</td><td>-</td><td>-</td><td>-</td></tr> <tr><td>38</td><td>-</td><td>200,0*</td><td>-</td><td>-</td><td>-</td><td>-</td><td>-</td><td>-</td><td>-</td><td>-</td><td>-</td></tr> <tr><td>42</td><td>-</td><td>197,0*</td><td>-</td><td>-</td><td>-</td><td>-</td><td>-</td><td>-</td><td>-</td><td>-</td><td>-</td></tr> <tr><td>44</td><td>105,0</td><td>203,0</td><td>-</td><td>-</td><td>-</td><td>-</td><td>-</td><td>-</td><td>-</td><td>203,0</td><td>-</td></tr> <tr><td>46</td><td>99,0</td><td>203,0</td><td>-</td><td>-</td><td>-</td><td>-</td><td>-</td><td>-</td><td>-</td><td>203,0</td><td>-</td></tr> <tr><td>50</td><td>88,0</td><td>200,0</td><td>-</td><td>-</td><td>-</td><td>-</td><td>-</td><td>-</td><td>-</td><td>203,0</td><td>-</td></tr> <tr><td>54</td><td>78,5</td><td>198,0</td><td>-</td><td>-</td><td>-</td><td>-</td><td>-</td><td>-</td><td>-</td><td>201,0</td><td>-</td></tr> <tr><td>58</td><td>70,5</td><td>196,0</td><td>-</td><td>-</td><td>-</td><td>-</td><td>-</td><td>-</td><td>-</td><td>200,0</td><td>-</td></tr> <tr><td>62</td><td>63,0</td><td>193,0</td><td>-</td><td>-</td><td>-</td><td>-</td><td>-</td><td>-</td><td>-</td><td>199,0</td><td>-</td></tr> <tr><td>66</td><td>56,5</td><td>179,0</td><td>-</td><td>-</td><td>-</td><td>-</td><td>-</td><td>-</td><td>-</td><td>195,0</td><td>-</td></tr> <tr><td>68</td><td>53,5</td><td>171,0</td><td>193,0</td><td>-</td><td>-</td><td>-</td><td>-</td><td>-</td><td>-</td><td>193,5</td><td>-</td></tr> <tr><td>70</td><td>50,5</td><td>163,0</td><td>193,0</td><td>-</td><td>-</td><td>-</td><td>-</td><td>-</td><td>-</td><td>192,0</td><td>-</td></tr> <tr><td>74</td><td>44,7</td><td>148,0</td><td>185,0</td><td>-</td><td>-</td><td>-</td><td>-</td><td>-</td><td>-</td><td>188,0</td><td>-</td></tr> <tr><td>78</td><td>39,1</td><td>136,0</td><td>168,0</td><td>-</td><td>-</td><td>-</td><td>-</td><td>-</td><td>-</td><td>184,0</td><td>-</td></tr> <tr><td>82</td><td>34,2</td><td>124,5</td><td>153,0</td><td>-</td><td>-</td><td>-</td><td>-</td><td>-</td><td>-</td><td>173,0</td><td>-</td></tr> <tr><td>86</td><td>29,8</td><td>114,5</td><td>140,0</td><td>-</td><td>-</td><td>-</td><td>-</td><td>-</td><td>-</td><td>164,0</td><td>-</td></tr> <tr><td>90</td><td>25,8</td><td>105,5</td><td>128,0</td><td>156,0</td><td>-</td><td>-</td><td>-</td><td>-</td><td>-</td><td>155,0</td><td>-</td></tr> <tr><td>94</td><td>22,3</td><td>97,5</td><td>118,0</td><td>143,0</td><td>-</td><td>-</td><td>-</td><td>-</td><td>-</td><td>147,0</td><td>-</td></tr> <tr><td>96</td><td>20,6</td><td>94,0</td><td>113,0</td><td>137,0</td><td>-</td><td>-</td><td>-</td><td>-</td><td>-</td><td>143,0</td><td>-</td></tr> <tr><td>98</td><td>-</td><td>-</td><td>109,0</td><td>131,0</td><td>-</td><td>-</td><td>-</td><td>-</td><td>-</td><td>139,0</td><td>-</td></tr> <tr><td>102</td><td>-</td><td>-</td><td>100,0</td><td>120,0</td><td>-</td><td>-</td><td>-</td><td>-</td><td>-</td><td>133,0</td><td>-</td></tr> <tr><td>106</td><td>-</td><td>-</td><td>93,0</td><td>111,0</td><td>-</td><td>-</td><td>-</td><td>-</td><td>-</td><td>126,0</td><td>-</td></tr> <tr><td>108</td><td>-</td><td>-</td><td>89,5</td><td>106,0</td><td>-</td><td>-</td><td>-</td><td>-</td><td>-</td><td>122,0</td><td>-</td></tr> <tr><td>110</td><td>-</td><td>-</td><td>-</td><td>102,0</td><td>119,0</td><td>-</td><td>-</td><td>-</td><td>-</td><td>118,0</td><td>-</td></tr> <tr><td>114</td><td>-</td><td>-</td><td>-</td><td>94,5</td><td>111,0</td><td>-</td><td>-</td><td>-</td><td>-</td><td>107,0</td><td>-</td></tr> <tr><td>118</td><td>-</td><td>-</td><td>-</td><td>87,5</td><td>103,0</td><td>-</td><td>-</td><td>-</td><td>-</td><td>100,0</td><td>-</td></tr> <tr><td>122</td><td>-</td><td>-</td><td>-</td><td>-</td><td>95,5</td><td>-</td><td>-</td><td>-</td><td>-</td><td>91,5</td><td>-</td></tr> <tr><td>126</td><td>-</td><td>-</td><td>-</td><td>-</td><td>88,0</td><td>81,5</td><td>81,0</td><td>-</td><td>-</td><td>81,0</td><td>-</td></tr> <tr><td>130</td><td>-</td><td>-</td><td>-</td><td>-</td><td>-</td><td>77,0</td><td>71,0</td><td>-</td><td>-</td><td>71,0</td><td>-</td></tr> <tr><td>132</td><td>-</td><td>-</td><td>-</td><td>-</td><td>-</td><td>75,0</td><td>66,2</td><td>-</td><td>-</td><td>66,2</td><td>-</td></tr> <tr><td>134</td><td>-</td><td>-</td><td>-</td><td>-</td><td>-</td><td>-</td><td>61,5</td><td>-</td><td>-</td><td>61,5</td><td>-</td></tr> <tr><td>138</td><td>-</td><td>-</td><td>-</td><td>-</td><td>-</td><td>-</td><td>51,5</td><td>-</td><td>-</td><td>51,5</td><td>-</td></tr> </tbody> </table>												SWSL											SFSL	0 t - 640 t													85°	85°	75°	65°	55°	45°						m	t	t	t	t	t	t	t	t	t	t	t	36	-	201,0*	-	-	-	-	-	-	-	-	-	38	-	200,0*	-	-	-	-	-	-	-	-	-	42	-	197,0*	-	-	-	-	-	-	-	-	-	44	105,0	203,0	-	-	-	-	-	-	-	203,0	-	46	99,0	203,0	-	-	-	-	-	-	-	203,0	-	50	88,0	200,0	-	-	-	-	-	-	-	203,0	-	54	78,5	198,0	-	-	-	-	-	-	-	201,0	-	58	70,5	196,0	-	-	-	-	-	-	-	200,0	-	62	63,0	193,0	-	-	-	-	-	-	-	199,0	-	66	56,5	179,0	-	-	-	-	-	-	-	195,0	-	68	53,5	171,0	193,0	-	-	-	-	-	-	193,5	-	70	50,5	163,0	193,0	-	-	-	-	-	-	192,0	-	74	44,7	148,0	185,0	-	-	-	-	-	-	188,0	-	78	39,1	136,0	168,0	-	-	-	-	-	-	184,0	-	82	34,2	124,5	153,0	-	-	-	-	-	-	173,0	-	86	29,8	114,5	140,0	-	-	-	-	-	-	164,0	-	90	25,8	105,5	128,0	156,0	-	-	-	-	-	155,0	-	94	22,3	97,5	118,0	143,0	-	-	-	-	-	147,0	-	96	20,6	94,0	113,0	137,0	-	-	-	-	-	143,0	-	98	-	-	109,0	131,0	-	-	-	-	-	139,0	-	102	-	-	100,0	120,0	-	-	-	-	-	133,0	-	106	-	-	93,0	111,0	-	-	-	-	-	126,0	-	108	-	-	89,5	106,0	-	-	-	-	-	122,0	-	110	-	-	-	102,0	119,0	-	-	-	-	118,0	-	114	-	-	-	94,5	111,0	-	-	-	-	107,0	-	118	-	-	-	87,5	103,0	-	-	-	-	100,0	-	122	-	-	-	-	95,5	-	-	-	-	91,5	-	126	-	-	-	-	88,0	81,5	81,0	-	-	81,0	-	130	-	-	-	-	-	77,0	71,0	-	-	71,0	-	132	-	-	-	-	-	75,0	66,2	-	-	66,2	-	134	-	-	-	-	-	-	61,5	-	-	61,5	-	138	-	-	-	-	-	-	51,5	-	-	51,5	-
SWSL											SFSL																																																																																																																																																																																																																																																																																																																																																																																																																																																
0 t - 640 t																																																																																																																																																																																																																																																																																																																																																																																																																																																											
	85°	85°	75°	65°	55°	45°																																																																																																																																																																																																																																																																																																																																																																																																																																																					
m	t	t	t	t	t	t	t	t	t	t	t																																																																																																																																																																																																																																																																																																																																																																																																																																																
36	-	201,0*	-	-	-	-	-	-	-	-	-																																																																																																																																																																																																																																																																																																																																																																																																																																																
38	-	200,0*	-	-	-	-	-	-	-	-	-																																																																																																																																																																																																																																																																																																																																																																																																																																																
42	-	197,0*	-	-	-	-	-	-	-	-	-																																																																																																																																																																																																																																																																																																																																																																																																																																																
44	105,0	203,0	-	-	-	-	-	-	-	203,0	-																																																																																																																																																																																																																																																																																																																																																																																																																																																
46	99,0	203,0	-	-	-	-	-	-	-	203,0	-																																																																																																																																																																																																																																																																																																																																																																																																																																																
50	88,0	200,0	-	-	-	-	-	-	-	203,0	-																																																																																																																																																																																																																																																																																																																																																																																																																																																
54	78,5	198,0	-	-	-	-	-	-	-	201,0	-																																																																																																																																																																																																																																																																																																																																																																																																																																																
58	70,5	196,0	-	-	-	-	-	-	-	200,0	-																																																																																																																																																																																																																																																																																																																																																																																																																																																
62	63,0	193,0	-	-	-	-	-	-	-	199,0	-																																																																																																																																																																																																																																																																																																																																																																																																																																																
66	56,5	179,0	-	-	-	-	-	-	-	195,0	-																																																																																																																																																																																																																																																																																																																																																																																																																																																
68	53,5	171,0	193,0	-	-	-	-	-	-	193,5	-																																																																																																																																																																																																																																																																																																																																																																																																																																																
70	50,5	163,0	193,0	-	-	-	-	-	-	192,0	-																																																																																																																																																																																																																																																																																																																																																																																																																																																
74	44,7	148,0	185,0	-	-	-	-	-	-	188,0	-																																																																																																																																																																																																																																																																																																																																																																																																																																																
78	39,1	136,0	168,0	-	-	-	-	-	-	184,0	-																																																																																																																																																																																																																																																																																																																																																																																																																																																
82	34,2	124,5	153,0	-	-	-	-	-	-	173,0	-																																																																																																																																																																																																																																																																																																																																																																																																																																																
86	29,8	114,5	140,0	-	-	-	-	-	-	164,0	-																																																																																																																																																																																																																																																																																																																																																																																																																																																
90	25,8	105,5	128,0	156,0	-	-	-	-	-	155,0	-																																																																																																																																																																																																																																																																																																																																																																																																																																																
94	22,3	97,5	118,0	143,0	-	-	-	-	-	147,0	-																																																																																																																																																																																																																																																																																																																																																																																																																																																
96	20,6	94,0	113,0	137,0	-	-	-	-	-	143,0	-																																																																																																																																																																																																																																																																																																																																																																																																																																																
98	-	-	109,0	131,0	-	-	-	-	-	139,0	-																																																																																																																																																																																																																																																																																																																																																																																																																																																
102	-	-	100,0	120,0	-	-	-	-	-	133,0	-																																																																																																																																																																																																																																																																																																																																																																																																																																																
106	-	-	93,0	111,0	-	-	-	-	-	126,0	-																																																																																																																																																																																																																																																																																																																																																																																																																																																
108	-	-	89,5	106,0	-	-	-	-	-	122,0	-																																																																																																																																																																																																																																																																																																																																																																																																																																																
110	-	-	-	102,0	119,0	-	-	-	-	118,0	-																																																																																																																																																																																																																																																																																																																																																																																																																																																
114	-	-	-	94,5	111,0	-	-	-	-	107,0	-																																																																																																																																																																																																																																																																																																																																																																																																																																																
118	-	-	-	87,5	103,0	-	-	-	-	100,0	-																																																																																																																																																																																																																																																																																																																																																																																																																																																
122	-	-	-	-	95,5	-	-	-	-	91,5	-																																																																																																																																																																																																																																																																																																																																																																																																																																																
126	-	-	-	-	88,0	81,5	81,0	-	-	81,0	-																																																																																																																																																																																																																																																																																																																																																																																																																																																
130	-	-	-	-	-	77,0	71,0	-	-	71,0	-																																																																																																																																																																																																																																																																																																																																																																																																																																																
132	-	-	-	-	-	75,0	66,2	-	-	66,2	-																																																																																																																																																																																																																																																																																																																																																																																																																																																
134	-	-	-	-	-	-	61,5	-	-	61,5	-																																																																																																																																																																																																																																																																																																																																																																																																																																																
138	-	-	-	-	-	-	51,5	-	-	51,5	-																																																																																																																																																																																																																																																																																																																																																																																																																																																

6 m steps of luffing jib is standard · 6 m Stufung der Wippe ist Standard · Des paliers de 6 m sont de série pour la fléchette

Main boom angle 88°, 85°, 75°, 65°, 55° and 45°; capacities for intermediate boom positions are calculated by the crane control system IC-1  
 Hauptauslegerwinkel 88°, 85°, 75°, 65°, 55° und 45°; Traglasten für Zwischenstellungen des Hauptauslegers werden von der Kransteuerung IC-1 berechnet

Jarret de flèche principale 88°, 85°, 75°, 65°, 55° et 45° ; le système de commande de la grue IC-1 calcule les charges pour les positions intermédiaires de la flèche

\* Main boom angle 88° · Hauptauslegerwinkel 88° · Jarret de flèche principale 88°

295 t + 60 t ZB 19-30 m 10,5 m 9.8 m/s 360° ISO

54 m + 108 m		SWSL						SFSL
		0 t - 640 t						
		85°	85°	75°	65°	55°	45°	
m	t	t	t	t	t	t	t	
40	-	154,0*	-	-	-	-	-	
42	-	154,0*	-	-	-	-	-	
46	-	151,0*	-	-	-	-	-	
48	85,5	155,0	-	-	-	-	155,0	
50	80,5	154,0	-	-	-	-	154,0	
54	71,5	152,0	-	-	-	-	154,0	
58	63,5	150,0	-	-	-	-	152,0	
62	56,0	148,0	-	-	-	-	151,0	
66	49,9	146,0	-	-	-	-	149,0	
70	44,2	145,0	-	-	-	-	147,0	
74	39,0	143,0	143,0	-	-	-	144,0	
78	34,2	131,0	143,0	-	-	-	142,0	
82	29,3	120,0	143,0	-	-	-	139,0	
86	24,9	110,0	135,0	-	-	-	137,0	
88	22,8	105,0	129,0	-	-	-	136,0	
90	20,9	101,0	124,0	-	-	-	135,0	
94	17,3	93,0	113,0	-	-	-	132,0	
98	14,0	85,5	104,0	124,0	-	-	125,0	
100	12,5	82,0	100,0	121,0	-	-	121,5	
102	-	78,7	96,0	116,0	-	-	118,0	
106	-	72,7	88,0	106,0	-	-	112,0	
108	-	70,0	84,5	102,0	-	-	109,0	
110	-	-	81,0	97,5	-	-	106,0	
114	-	-	75,0	90,0	-	-	101,0	
118	-	-	69,0	83,0	-	-	96,5	
120	-	-	66,5	79,5	94,5	-	93,7	
122	-	-	-	76,5	90,5	-	91,0	
126	-	-	-	70,5	83,5	-	84,5	
128	-	-	-	68,0	80,0	-	80,7	
130	-	-	-	-	77,0	-	77,0	
134	-	-	-	-	71,0	-	68,5	
136	-	-	-	-	68,5	-	64,0	
138	-	-	-	-	-	62,0	59,5	
142	-	-	-	-	-	58,5	51,5	
144	-	-	-	-	-	57,0	47,3	
146	-	-	-	-	-	-	43,2	
150	-	-	-	-	-	-	34,8	

60 m + 36 m		SWSL						SFSL
		0 t - 640 t						
		85°	85°	75°	65°	55°	45°	
m	t	t	t	t	t	t	t	
18	-	573,0*	-	-	-	-	-	
20	-	564,0*	-	-	-	-	-	
22	-	545,0*	-	-	-	-	-	
24	280,0	600,0	-	-	-	-	584,0	
26	259,0	587,0	-	-	-	-	584,0	
28	240,0	574,0	-	-	-	-	584,0	
30	223,0	556,0	-	-	-	-	584,0	
34	195,0	459,0	-	-	-	-	584,0	
38	166,0	389,0	-	-	-	-	570,0	
39	160,5	375,0	568,0	-	-	-	562,0	
42	144,0	337,0	513,0	-	-	-	527,0	
46	-	-	429,0	-	-	-	473,0	
50	-	-	367,0	-	-	-	426,0	
52	-	-	341,0	-	-	-	406,0	
54	-	-	-	390,0	-	-	386,0	
58	-	-	-	360,0	-	-	352,0	
62	-	-	-	334,0	-	-	322,0	
63	-	-	-	328,0	-	-	313,7	
66	-	-	-	-	-	-	289,0	
67	-	-	-	-	282,0	-	281,0	
70	-	-	-	-	267,0	-	257,0	
72	-	-	-	-	258,0	-	242,5	
74	-	-	-	-	-	-	228,0	
78	-	-	-	-	-	202,0	202,0	
80	-	-	-	-	-	196,0	191,5	
82	-	-	-	-	-	-	184,0	
86	-	-	-	-	-	-	165,0	

60 m + 48 m		SWSL						SFSL
		0 t - 640 t						
		85°	85°	75°	65°	55°	45°	
m	t	t	t	t	t	t	t	
22	-	457,0*	-	-	-	-	-	
24	-	446,0*	-	-	-	-	-	
26	-	434,0*	-	-	-	-	-	
28	225,0	476,0	-	-	-	-	463,0	
30	209,0	468,0	-	-	-	-	463,0	
34	183,0	453,0	-	-	-	-	463,0	
38	162,0	419,0	-	-	-	-	463,0	
42	141,0	362,0	-	-	-	-	462,0	
45	127,5	327,5	464,0	-	-	-	447,0	
46	123,0	317,0	461,0	-	-	-	441,0	
50	109,0	281,0	394,0	-	-	-	418,0	
54	97,5	248,0	342,0	-	-	-	389,0	
58	-	-	302,0	-	-	-	354,0	
62	-	-	269,0	327,0	-	-	324,0	
64	-	-	-	255,0	316,0	-	310,5	
66	-	-	-	305,0	-	-	297,0	
70	-	-	-	284,0	-	-	274,0	
74	-	-	-	255,0	-	-	247,0	
75	-	-	-	248,0	-	-	240,7	
76	-	-	-	-	235,0	-	234,5	
78	-	-	-	-	227,0	-	222,0	
82	-	-	-	-	213,0	-	199,0	
84	-	-	-	-	207,0	-	188,0	
86	-	-	-	-	-	-	177,0	
89	-	-	-	-	-	164,0	162,2	
90	-	-	-	-	-	161,0	159,0	
92	-	-	-	-	-	157,0	153,5	
94	-	-	-	-	-	-	148,0	
98	-	-	-	-	-	-	129,0	

6 m steps of luffing jib is standard · 6 m Stufung der Wippe ist Standard · Des paliers de 6 m sont de série pour la fléchette

Main boom angle 88°, 85°, 75°, 65°, 55° and 45°; capacities for intermediate boom positions are calculated by the crane control system IC-1

Hauptauslegerwinkel 88°, 85°, 75°, 65°, 55° und 45°; Traglasten für Zwischenstellungen des Hauptauslegers werden von der Kransteuerung IC-1 berechnet

Jarret de flèche principale 88°, 85°, 75°, 65°, 55° et 45° ; le système de commande de la grue IC-1 calcule les charges pour les positions intermédiaires de la flèche

\* Main boom angle 88° · Hauptauslegerwinkel 88° · Jarret de flèche principale 88°

295 t + 60 t ZB		19-30 m		10,5 m		9.8 m/s		360°		ISO	
60 m + 60 m						60 m + 72 m					
		SWSL					SFSL				
		0 t	0 t - 640 t								
		85°	85°	75°	65°	55°	45°				
m	t	t	t	t	t	t	t	t	t		
26	-	364,0*	-	-	-	-	-	-	-		
28	-	357,0*	-	-	-	-	-	-	-		
30	-	350,0*	-	-	-	-	-	-	-		
32	184,0	380,0	-	-	-	-	-	370,0	-		
34	172,0	376,0	-	-	-	-	-	370,0	-		
38	152,0	367,0	-	-	-	-	-	370,0	-		
42	136,0	357,0	-	-	-	-	-	370,0	-		
46	122,0	333,0	-	-	-	-	-	370,0	-		
50	108,0	295,0	-	-	-	-	-	363,0	-		
52	102,0	278,0	384,0	-	-	-	-	354,5	-		
54	96,5	264,0	360,0	-	-	-	-	347,0	-		
58	86,0	238,0	316,0	-	-	-	-	334,0	-		
62	77,5	216,0	282,0	-	-	-	-	321,0	-		
66	70,0	182,0	253,0	-	-	-	-	302,0	-		
69	-	-	234,5	286,0	-	-	-	284,0	-		
70	-	-	229,0	282,0	-	-	-	278,0	-		
74	-	-	208,0	264,0	-	-	-	257,0	-		
76	-	-	199,0	252,0	-	-	-	248,0	-		
78	-	-	-	240,0	-	-	-	239,0	-		
82	-	-	-	218,0	-	-	-	217,0	-		
86	-	-	-	199,0	198,0	-	-	196,0	-		
90	-	-	-	-	186,0	-	-	177,0	-		
94	-	-	-	-	176,0	-	-	158,0	-		
95	-	-	-	-	174,0	-	-	153,7	-		
98	-	-	-	-	-	-	-	141,0	-		
99	-	-	-	-	-	-	139,0	137,7	-		
102	-	-	-	-	-	-	134,0	131,0	-		
103	-	-	-	-	-	-	132,0	127,7	-		
106	-	-	-	-	-	-	-	118,0	-		
110	-	-	-	-	-	-	-	103,0	-		
30	-	293,0*	-	-	-	-	-	-	-		
34	-	284,0*	-	-	-	-	-	-	-		
36	152,0	304,0	-	-	-	-	-	298,0	-		
38	143,0	303,0	-	-	-	-	-	298,0	-		
42	127,0	297,0	-	-	-	-	-	298,0	-		
46	113,0	292,0	-	-	-	-	-	298,0	-		
50	102,0	285,0	-	-	-	-	-	298,0	-		
54	92,0	266,0	-	-	-	-	-	295,0	-		
58	83,0	239,0	310,0	-	-	-	-	286,0	-		
62	74,5	216,0	284,0	-	-	-	-	278,0	-		
66	66,5	197,0	254,0	-	-	-	-	268,0	-		
70	59,5	180,0	229,0	-	-	-	-	260,0	-		
74	53,5	158,0	208,0	-	-	-	-	251,0	-		
76	50,5	147,0	199,0	-	-	-	-	245,5	-		
77	-	-	194,5	243,0	-	-	-	242,7	-		
78	-	-	190,0	241,0	-	-	-	240,0	-		
82	-	-	174,0	218,0	-	-	-	223,0	-		
86	-	-	160,0	198,0	-	-	-	207,0	-		
90	-	-	-	181,0	-	-	-	188,0	-		
94	-	-	-	166,0	-	-	-	171,0	-		
95	-	-	-	162,5	168,0	-	-	167,0	-		
96	-	-	-	159,0	166,0	-	-	163,0	-		
98	-	-	-	-	161,0	-	-	155,0	-		
102	-	-	-	-	152,0	-	-	139,0	-		
106	-	-	-	-	144,0	-	-	125,0	-		
110	-	-	-	-	-	-	115,0	114,0	-		
114	-	-	-	-	-	-	110,0	106,0	-		
118	-	-	-	-	-	-	-	93,0	-		
122	-	-	-	-	-	-	-	80,0	-		

6 m steps of luffing jib is standard · 6 m Stufung der Wippe ist Standard · Des paliers de 6 m sont de série pour la fléchette

Main boom angle 88°, 85°, 75°, 65°, 55° and 45°; capacities for intermediate boom positions are calculated by the crane control system IC-1  
Hauptauslegerwinkel 88°, 85°, 75°, 65°, 55° und 45°; Traglasten für Zwischenstellungen des Hauptauslegers werden von der Kransteuerung IC-1 berechnet

Jarret de flèche principale 88°, 85°, 75°, 65°, 55° et 45° ; le système de commande de la grue IC-1 calcule les charges pour les positions intermédiaires de la flèche

\* Main boom angle 88° · Hauptauslegerwinkel 88° · Jarret de flèche principale 88°

295 t + 60 t ZB									19-30 m		10,5 m		9.8 m/s		360°		ISO		
60 m + 84 m									60 m + 96 m										
SWSL									SWSL										
SFSL									SFSL										
0 t									0 t - 640 t										
85° 85° 75° 65° 55° 45°									85° 85° 75° 65° 55° 45°										
m	t	t	t	t	t	t	t	t	m	t	t	t	t	t	t	t	t	t	t
32	-	237,0*	-	-	-	-	-	-	36	-	190,0*	-	-	-	-	-	-	-	-
34	-	236,0*	-	-	-	-	-	-	38	-	189,0*	-	-	-	-	-	-	-	-
38	-	230,0*	-	-	-	-	-	-	42	-	185,0*	-	-	-	-	-	-	-	-
40	123,0	244,0	-	-	-	-	-	240,0	44	101,0	193,0	-	-	-	-	-	-	-	192,0
42	116,0	243,0	-	-	-	-	-	240,0	46	95,0	193,0	-	-	-	-	-	-	-	192,0
46	103,0	240,0	-	-	-	-	-	240,0	50	84,5	190,0	-	-	-	-	-	-	-	192,0
50	92,0	236,0	-	-	-	-	-	240,0	54	75,0	188,0	-	-	-	-	-	-	-	191,0
54	82,5	232,0	-	-	-	-	-	240,0	58	67,0	186,0	-	-	-	-	-	-	-	191,0
58	74,0	228,0	-	-	-	-	-	240,0	62	60,0	184,0	-	-	-	-	-	-	-	190,0
62	67,0	210,0	-	-	-	-	-	235,0	66	53,5	181,0	-	-	-	-	-	-	-	187,0
64	63,5	200,0	242,0	-	-	-	-	232,0	70	48,0	171,0	185,0	-	-	-	-	-	-	184,0
66	59,5	190,0	242,0	-	-	-	-	229,0	74	42,8	156,0	185,0	-	-	-	-	-	-	181,0
70	52,5	173,0	223,0	-	-	-	-	223,0	78	37,9	143,0	181,0	-	-	-	-	-	-	178,0
74	46,7	159,0	202,0	-	-	-	-	217,0	82	33,0	131,5	165,0	-	-	-	-	-	-	174,0
78	41,3	146,0	183,0	-	-	-	-	211,0	86	28,6	121,0	151,0	-	-	-	-	-	-	171,0
82	36,5	133,0	167,0	-	-	-	-	204,0	90	24,7	111,5	138,0	-	-	-	-	-	-	167,0
86	32,3	117,5	153,0	192,0	-	-	-	193,0	92	22,9	107,0	133,0	165,0	-	-	-	-	-	163,0
88	30,4	109,0	147,0	183,0	-	-	-	188,5	94	21,2	101,5	127,0	158,0	-	-	-	-	-	159,0
90	-	-	141,0	175,0	-	-	-	184,0	98	18,1	89,7	117,0	144,0	-	-	-	-	-	151,0
94	-	-	130,0	160,0	-	-	-	175,0	100	16,7	83,5	113,0	138,0	-	-	-	-	-	147,5
98	-	-	120,0	147,0	-	-	-	159,0	102	-	-	108,0	133,0	-	-	-	-	-	144,0
102	-	-	-	135,0	-	-	-	145,0	106	-	-	100,0	122,0	-	-	-	-	-	137,0
104	-	-	-	130,0	139,0	-	-	138,0	110	-	-	93,0	113,0	-	-	-	-	-	126,0
106	-	-	-	125,0	135,0	-	-	131,0	114	-	-	-	104,0	116,0	-	-	-	-	114,0
108	-	-	-	120,0	131,0	-	-	124,5	118	-	-	-	96,5	109,0	-	-	-	-	102,0
110	-	-	-	-	127,0	-	-	118,0	120	-	-	-	93,0	106,0	-	-	-	-	97,0
114	-	-	-	-	121,0	-	-	105,0	122	-	-	-	-	103,0	-	-	-	-	92,0
118	-	-	-	-	115,0	-	-	96,0	126	-	-	-	-	98,0	-	-	-	-	82,5
120	-	-	-	-	-	-	-	93,5	128	-	-	-	-	95,0	-	-	-	-	79,5
122	-	-	-	-	-	-	-	91,5	130	-	-	-	-	-	-	-	-	-	77,5
126	-	-	-	-	-	-	-	87,0	134	-	-	-	-	-	-	-	-	-	73,5
130	-	-	-	-	-	-	-	68,0	136	-	-	-	-	-	-	-	-	-	72,0
134	-	-	-	-	-	-	-	57,0	138	-	-	-	-	-	-	-	-	-	59,5
									142	-	-	-	-	-	-	-	-	-	50,0

6 m steps of luffing jib is standard · 6 m Stufung der Wippe ist Standard · Des paliers de 6 m sont de série pour la fléchette

Main boom angle 88°, 85°, 75°, 65°, 55° and 45°; capacities for intermediate boom positions are calculated by the crane control system IC-1  
 Hauptauslegerwinkel 88°, 85°, 75°, 65°, 55° und 45°; Traglasten für Zwischenstellungen des Hauptauslegers werden von der Kransteuerung IC-1 berechnet

Jarret de flèche principale 88°, 85°, 75°, 65°, 55° et 45° ; le système de commande de la grue IC-1 calcule les charges pour les positions intermédiaires de la flèche

\* Main boom angle 88° · Hauptauslegerwinkel 88° · Jarret de flèche principale 88°

295 t + 60 t ZB 19-30 m 10,5 m 9.8 m/s 360° ISO

**60 m + 108 m**

m	SWSL							SFSL
	0 t		0 t - 640 t					
	85°	85°	75°	65°	55°	45°		
t	t	t	t	t	t	t	t	
40	-	147,0*	-	-	-	-	-	
42	-	146,0*	-	-	-	-	-	
46	-	143,0*	-	-	-	-	-	
48	81,5	147,0	-	-	-	-	147,0	
50	76,5	147,0	-	-	-	-	147,0	
54	68,0	145,0	-	-	-	-	147,0	
58	60,0	144,0	-	-	-	-	146,0	
62	53,0	142,0	-	-	-	-	144,0	
66	47,1	140,0	-	-	-	-	143,0	
70	41,5	138,0	-	-	-	-	141,0	
74	36,5	137,0	-	-	-	-	139,0	
76	34,2	136,0	135,0	-	-	-	138,0	
78	31,9	135,0	135,0	-	-	-	137,0	
82	27,8	127,0	135,0	-	-	-	135,0	
84	25,8	121,0	135,0	-	-	-	133,5	
86	23,7	116,5	135,0	-	-	-	132,0	
90	19,7	107,5	134,0	-	-	-	130,0	
94	16,1	99,0	123,0	-	-	-	128,0	
98	12,9	91,2	113,0	-	-	-	125,0	
100	11,4	87,5	108,0	119,0	-	-	124,0	
102	-	84,0	104,0	119,0	-	-	123,0	
106	-	75,7	95,5	117,0	-	-	121,0	
108	-	71,0	92,0	112,0	-	-	118,5	
110	-	-	88,0	108,0	-	-	116,0	
114	-	-	81,5	99,5	-	-	110,0	
118	-	-	75,5	92,0	-	-	105,0	
122	-	-	69,5	85,0	97,0	-	96,5	
126	-	-	-	78,5	91,5	-	86,5	
130	-	-	-	72,5	86,5	-	77,0	
132	-	-	-	70,0	83,5	-	72,5	
134	-	-	-	-	80,5	-	69,0	
138	-	-	-	-	74,5	-	64,0	
140	-	-	-	-	71,5	-	60,7	
142	-	-	-	-	-	59,5	57,5	
146	-	-	-	-	-	56,0	49,5	
148	-	-	-	-	-	54,5	45,5	
150	-	-	-	-	-	-	41,5	
154	-	-	-	-	-	-	33,4	

**66 m + 36 m**

m	SWSL							SFSL
	0 t		0 t - 640 t					
	85°	85°	75°	65°	55°	45°		
t	t	t	t	t	t	t	t	
18	-	536,0*	-	-	-	-	-	
20	-	528,0*	-	-	-	-	-	
22	-	511,0*	-	-	-	-	-	
24	270,0	562,0	-	-	-	-	546,0	
26	249,0	551,0	-	-	-	-	546,0	
28	231,0	539,0	-	-	-	-	546,0	
30	216,0	528,0	-	-	-	-	546,0	
34	189,0	469,0	-	-	-	-	546,0	
38	164,0	396,0	-	-	-	-	538,0	
41	147,5	354,5	537,0	-	-	-	520,0	
42	142,0	342,0	530,0	-	-	-	513,0	
46	-	-	457,0	-	-	-	468,0	
50	-	-	388,0	-	-	-	421,0	
54	-	-	335,0	-	-	-	381,0	
56	-	-	-	366,0	-	-	363,5	
58	-	-	-	352,0	-	-	346,0	
62	-	-	-	326,0	-	-	316,0	
66	-	-	-	304,0	-	-	290,0	
70	-	-	-	-	-	-	267,0	
71	-	-	-	-	264,0	-	260,5	
74	-	-	-	-	252,0	-	241,0	
76	-	-	-	-	244,0	-	228,0	
78	-	-	-	-	-	-	215,0	
82	-	-	-	-	-	-	190,0	
86	-	-	-	-	-	-	167,0	
90	-	-	-	-	-	-	153,0	

**66 m + 48 m**

m	t	t	t	t	t	t	t
22	-	424,0*	-	-	-	-	-
24	-	419,0*	-	-	-	-	-
26	-	408,0*	-	-	-	-	-
28	216,0	445,0	-	-	-	-	433,0
30	202,0	441,0	-	-	-	-	433,0
34	177,0	427,0	-	-	-	-	433,0
38	156,0	412,0	-	-	-	-	433,0
42	139,0	368,0	-	-	-	-	433,0
46	122,0	321,0	-	-	-	-	422,0
47	118,0	311,5	441,0	-	-	-	416,5
50	107,0	285,0	417,0	-	-	-	401,0
54	95,5	255,0	360,0	-	-	-	383,0
58	-	-	316,0	-	-	-	349,0
62	-	-	280,0	-	-	-	319,0
64	-	-	265,0	308,0	-	-	306,0
66	-	-	251,0	297,0	-	-	293,0
70	-	-	-	278,0	-	-	269,0
74	-	-	-	261,0	-	-	248,0
77	-	-	-	249,0	-	-	234,5
78	-	-	-	-	-	-	230,0
80	-	-	-	-	222,0	-	219,5
82	-	-	-	-	215,0	-	209,0
86	-	-	-	-	202,0	-	187,0
87	-	-	-	-	200,0	-	182,0
90	-	-	-	-	-	-	167,0
93	-	-	-	-	-	154,0	152,7
94	-	-	-	-	-	152,0	148,0
96	-	-	-	-	-	148,0	139,0
98	-	-	-	-	-	-	133,0
102	-	-	-	-	-	-	123,0

6 m steps of luffing jib is standard · 6 m Stufung der Wippe ist Standard · Des paliers de 6 m sont de série pour la fléchette

Main boom angle 88°, 85°, 75°, 65°, 55° and 45°;  
capacities for intermediate boom positions are calculated by the crane control system IC-1

Hauptauslegerwinkel 88°, 85°, 75°, 65°, 55° und 45°;  
Traglasten für Zwischenstellungen des Hauptauslegers werden von der Kransteuerung IC-1 berechnet

Jarret de flèche principale 88°, 85°, 75°, 65°, 55° et 45°;  
le système de commande de la grue IC-1 calcule les charges pour les positions intermédiaires de la flèche

\* Main boom angle 88° · Hauptauslegerwinkel 88° · Jarret de flèche principale 88°

295 t + 60 t ZB		19-30 m		10,5 m		9.8 m/s		360°		ISO																																																																																																																																																																																																																																																																																																																
66 m + 60 m						66 m + 72 m																																																																																																																																																																																																																																																																																																																				
<table border="1"> <thead> <tr> <th rowspan="3">m</th> <th colspan="7">SWSL</th> <th>SFSL</th> </tr> <tr> <th colspan="1">0 t</th> <th colspan="6">0 t - 640 t</th> <th></th> </tr> <tr> <th>85°</th> <th>85°</th> <th>75°</th> <th>65°</th> <th>55°</th> <th>45°</th> <th></th> </tr> </thead> <tbody> <tr> <td>26</td> <td>-</td> <td>344,0*</td> <td>-</td> <td>-</td> <td>-</td> <td>-</td> <td>-</td> <td>-</td> </tr> <tr> <td>28</td> <td>-</td> <td>337,0*</td> <td>-</td> <td>-</td> <td>-</td> <td>-</td> <td>-</td> <td>-</td> </tr> <tr> <td>30</td> <td>-</td> <td>331,0*</td> <td>-</td> <td>-</td> <td>-</td> <td>-</td> <td>-</td> <td>-</td> </tr> <tr> <td>32</td> <td>177,0</td> <td>357,0</td> <td>-</td> <td>-</td> <td>-</td> <td>-</td> <td>349,0</td> <td></td> </tr> <tr> <td>34</td> <td>166,0</td> <td>355,0</td> <td>-</td> <td>-</td> <td>-</td> <td>-</td> <td>349,0</td> <td></td> </tr> <tr> <td>38</td> <td>147,0</td> <td>346,0</td> <td>-</td> <td>-</td> <td>-</td> <td>-</td> <td>349,0</td> <td></td> </tr> <tr> <td>42</td> <td>131,0</td> <td>337,0</td> <td>-</td> <td>-</td> <td>-</td> <td>-</td> <td>349,0</td> <td></td> </tr> <tr> <td>46</td> <td>117,0</td> <td>328,0</td> <td>-</td> <td>-</td> <td>-</td> <td>-</td> <td>349,0</td> <td></td> </tr> <tr> <td>50</td> <td>106,0</td> <td>299,0</td> <td>-</td> <td>-</td> <td>-</td> <td>-</td> <td>345,0</td> <td></td> </tr> <tr> <td>54</td> <td>95,0</td> <td>267,0</td> <td>367,0</td> <td>-</td> <td>-</td> <td>-</td> <td>333,0</td> <td></td> </tr> <tr> <td>58</td> <td>84,5</td> <td>240,0</td> <td>332,0</td> <td>-</td> <td>-</td> <td>-</td> <td>318,0</td> <td></td> </tr> <tr> <td>62</td> <td>76,0</td> <td>218,0</td> <td>294,0</td> <td>-</td> <td>-</td> <td>-</td> <td>306,0</td> <td></td> </tr> <tr> <td>66</td> <td>68,5</td> <td>188,0</td> <td>263,0</td> <td>-</td> <td>-</td> <td>-</td> <td>294,0</td> <td></td> </tr> <tr> <td>70</td> <td>-</td> <td>-</td> <td>237,0</td> <td>-</td> <td>-</td> <td>-</td> <td>274,0</td> <td></td> </tr> <tr> <td>72</td> <td>-</td> <td>-</td> <td>226,0</td> <td>266,0</td> <td>-</td> <td>-</td> <td>263,5</td> <td></td> </tr> <tr> <td>74</td> <td>-</td> <td>-</td> <td>215,0</td> <td>257,0</td> <td>-</td> <td>-</td> <td>253,0</td> <td></td> </tr> <tr> <td>78</td> <td>-</td> <td>-</td> <td>197,0</td> <td>242,0</td> <td>-</td> <td>-</td> <td>234,0</td> <td></td> </tr> <tr> <td>82</td> <td>-</td> <td>-</td> <td>-</td> <td>228,0</td> <td>-</td> <td>-</td> <td>217,0</td> <td></td> </tr> <tr> <td>86</td> <td>-</td> <td>-</td> <td>-</td> <td>210,0</td> <td>-</td> <td>-</td> <td>202,0</td> <td></td> </tr> <tr> <td>88</td> <td>-</td> <td>-</td> <td>-</td> <td>201,0</td> <td>-</td> <td>-</td> <td>193,5</td> <td></td> </tr> <tr> <td>89</td> <td>-</td> <td>-</td> <td>-</td> <td>-</td> <td>191,0</td> <td>-</td> <td>189,2</td> <td></td> </tr> <tr> <td>90</td> <td>-</td> <td>-</td> <td>-</td> <td>-</td> <td>188,0</td> <td>-</td> <td>185,0</td> <td></td> </tr> <tr> <td>94</td> <td>-</td> <td>-</td> <td>-</td> <td>-</td> <td>177,0</td> <td>-</td> <td>167,0</td> <td></td> </tr> <tr> <td>98</td> <td>-</td> <td>-</td> <td>-</td> <td>-</td> <td>168,0</td> <td>-</td> <td>150,0</td> <td></td> </tr> <tr> <td>102</td> <td>-</td> <td>-</td> <td>-</td> <td>-</td> <td>-</td> <td>-</td> <td>134,0</td> <td></td> </tr> <tr> <td>103</td> <td>-</td> <td>-</td> <td>-</td> <td>-</td> <td>-</td> <td>130,0</td> <td>130,2</td> <td></td> </tr> <tr> <td>106</td> <td>-</td> <td>-</td> <td>-</td> <td>-</td> <td>-</td> <td>125,0</td> <td>119,0</td> <td></td> </tr> <tr> <td>107</td> <td>-</td> <td>-</td> <td>-</td> <td>-</td> <td>-</td> <td>124,0</td> <td>115,2</td> <td></td> </tr> <tr> <td>110</td> <td>-</td> <td>-</td> <td>-</td> <td>-</td> <td>-</td> <td>-</td> <td>109,0</td> <td></td> </tr> <tr> <td>114</td> <td>-</td> <td>-</td> <td>-</td> <td>-</td> <td>-</td> <td>-</td> <td>98,5</td> <td></td> </tr> </tbody> </table>												m	SWSL							SFSL	0 t	0 t - 640 t							85°	85°	75°	65°	55°	45°		26	-	344,0*	-	-	-	-	-	-	28	-	337,0*	-	-	-	-	-	-	30	-	331,0*	-	-	-	-	-	-	32	177,0	357,0	-	-	-	-	349,0		34	166,0	355,0	-	-	-	-	349,0		38	147,0	346,0	-	-	-	-	349,0		42	131,0	337,0	-	-	-	-	349,0		46	117,0	328,0	-	-	-	-	349,0		50	106,0	299,0	-	-	-	-	345,0		54	95,0	267,0	367,0	-	-	-	333,0		58	84,5	240,0	332,0	-	-	-	318,0		62	76,0	218,0	294,0	-	-	-	306,0		66	68,5	188,0	263,0	-	-	-	294,0		70	-	-	237,0	-	-	-	274,0		72	-	-	226,0	266,0	-	-	263,5		74	-	-	215,0	257,0	-	-	253,0		78	-	-	197,0	242,0	-	-	234,0		82	-	-	-	228,0	-	-	217,0		86	-	-	-	210,0	-	-	202,0		88	-	-	-	201,0	-	-	193,5		89	-	-	-	-	191,0	-	189,2		90	-	-	-	-	188,0	-	185,0		94	-	-	-	-	177,0	-	167,0		98	-	-	-	-	168,0	-	150,0		102	-	-	-	-	-	-	134,0		103	-	-	-	-	-	130,0	130,2		106	-	-	-	-	-	125,0	119,0		107	-	-	-	-	-	124,0	115,2		110	-	-	-	-	-	-	109,0		114	-	-	-	-	-	-	98,5										
m	SWSL							SFSL																																																																																																																																																																																																																																																																																																																		
	0 t	0 t - 640 t																																																																																																																																																																																																																																																																																																																								
	85°	85°	75°	65°	55°	45°																																																																																																																																																																																																																																																																																																																				
26	-	344,0*	-	-	-	-	-	-																																																																																																																																																																																																																																																																																																																		
28	-	337,0*	-	-	-	-	-	-																																																																																																																																																																																																																																																																																																																		
30	-	331,0*	-	-	-	-	-	-																																																																																																																																																																																																																																																																																																																		
32	177,0	357,0	-	-	-	-	349,0																																																																																																																																																																																																																																																																																																																			
34	166,0	355,0	-	-	-	-	349,0																																																																																																																																																																																																																																																																																																																			
38	147,0	346,0	-	-	-	-	349,0																																																																																																																																																																																																																																																																																																																			
42	131,0	337,0	-	-	-	-	349,0																																																																																																																																																																																																																																																																																																																			
46	117,0	328,0	-	-	-	-	349,0																																																																																																																																																																																																																																																																																																																			
50	106,0	299,0	-	-	-	-	345,0																																																																																																																																																																																																																																																																																																																			
54	95,0	267,0	367,0	-	-	-	333,0																																																																																																																																																																																																																																																																																																																			
58	84,5	240,0	332,0	-	-	-	318,0																																																																																																																																																																																																																																																																																																																			
62	76,0	218,0	294,0	-	-	-	306,0																																																																																																																																																																																																																																																																																																																			
66	68,5	188,0	263,0	-	-	-	294,0																																																																																																																																																																																																																																																																																																																			
70	-	-	237,0	-	-	-	274,0																																																																																																																																																																																																																																																																																																																			
72	-	-	226,0	266,0	-	-	263,5																																																																																																																																																																																																																																																																																																																			
74	-	-	215,0	257,0	-	-	253,0																																																																																																																																																																																																																																																																																																																			
78	-	-	197,0	242,0	-	-	234,0																																																																																																																																																																																																																																																																																																																			
82	-	-	-	228,0	-	-	217,0																																																																																																																																																																																																																																																																																																																			
86	-	-	-	210,0	-	-	202,0																																																																																																																																																																																																																																																																																																																			
88	-	-	-	201,0	-	-	193,5																																																																																																																																																																																																																																																																																																																			
89	-	-	-	-	191,0	-	189,2																																																																																																																																																																																																																																																																																																																			
90	-	-	-	-	188,0	-	185,0																																																																																																																																																																																																																																																																																																																			
94	-	-	-	-	177,0	-	167,0																																																																																																																																																																																																																																																																																																																			
98	-	-	-	-	168,0	-	150,0																																																																																																																																																																																																																																																																																																																			
102	-	-	-	-	-	-	134,0																																																																																																																																																																																																																																																																																																																			
103	-	-	-	-	-	130,0	130,2																																																																																																																																																																																																																																																																																																																			
106	-	-	-	-	-	125,0	119,0																																																																																																																																																																																																																																																																																																																			
107	-	-	-	-	-	124,0	115,2																																																																																																																																																																																																																																																																																																																			
110	-	-	-	-	-	-	109,0																																																																																																																																																																																																																																																																																																																			
114	-	-	-	-	-	-	98,5																																																																																																																																																																																																																																																																																																																			
<table border="1"> <thead> <tr> <th rowspan="3">m</th> <th colspan="7">SWSL</th> <th>SFSL</th> </tr> <tr> <th colspan="1">0 t</th> <th colspan="6">0 t - 640 t</th> <th></th> </tr> <tr> <th>85°</th> <th>85°</th> <th>75°</th> <th>65°</th> <th>55°</th> <th>45°</th> <th></th> </tr> </thead> <tbody> <tr> <td>30</td> <td>-</td> <td>277,0*</td> <td>-</td> <td>-</td> <td>-</td> <td>-</td> <td>-</td> <td>-</td> </tr> <tr> <td>34</td> <td>-</td> <td>269,0*</td> <td>-</td> <td>-</td> <td>-</td> <td>-</td> <td>-</td> <td>-</td> </tr> <tr> <td>36</td> <td>146,0</td> <td>288,0</td> <td>-</td> <td>-</td> <td>-</td> <td>-</td> <td>282,0</td> <td></td> </tr> <tr> <td>38</td> <td>137,0</td> <td>287,0</td> <td>-</td> <td>-</td> <td>-</td> <td>-</td> <td>282,0</td> <td></td> </tr> <tr> <td>42</td> <td>122,0</td> <td>282,0</td> <td>-</td> <td>-</td> <td>-</td> <td>-</td> <td>282,0</td> <td></td> </tr> <tr> <td>46</td> <td>109,0</td> <td>276,0</td> <td>-</td> <td>-</td> <td>-</td> <td>-</td> <td>282,0</td> <td></td> </tr> <tr> <td>50</td> <td>98,0</td> <td>270,0</td> <td>-</td> <td>-</td> <td>-</td> <td>-</td> <td>282,0</td> <td></td> </tr> <tr> <td>54</td> <td>88,5</td> <td>264,0</td> <td>-</td> <td>-</td> <td>-</td> <td>-</td> <td>282,0</td> <td></td> </tr> <tr> <td>58</td> <td>80,0</td> <td>244,0</td> <td>-</td> <td>-</td> <td>-</td> <td>-</td> <td>274,0</td> <td></td> </tr> <tr> <td>60</td> <td>76,0</td> <td>232,0</td> <td>295,0</td> <td>-</td> <td>-</td> <td>-</td> <td>269,0</td> <td></td> </tr> <tr> <td>62</td> <td>72,5</td> <td>220,0</td> <td>293,0</td> <td>-</td> <td>-</td> <td>-</td> <td>265,0</td> <td></td> </tr> <tr> <td>66</td> <td>65,0</td> <td>200,0</td> <td>267,0</td> <td>-</td> <td>-</td> <td>-</td> <td>257,0</td> <td></td> </tr> <tr> <td>70</td> <td>58,0</td> <td>183,0</td> <td>240,0</td> <td>-</td> <td>-</td> <td>-</td> <td>248,0</td> <td></td> </tr> <tr> <td>74</td> <td>52,0</td> <td>162,0</td> <td>217,0</td> <td>-</td> <td>-</td> <td>-</td> <td>240,0</td> <td></td> </tr> <tr> <td>78</td> <td>47,0</td> <td>139,0</td> <td>198,0</td> <td>-</td> <td>-</td> <td>-</td> <td>232,0</td> <td></td> </tr> <tr> <td>80</td> <td>-</td> <td>-</td> <td>189,0</td> <td>230,0</td> <td>-</td> <td>-</td> <td>225,5</td> <td></td> </tr> <tr> <td>82</td> <td>-</td> <td>-</td> <td>181,0</td> <td>223,0</td> <td>-</td> <td>-</td> <td>219,0</td> <td></td> </tr> <tr> <td>86</td> <td>-</td> <td>-</td> <td>166,0</td> <td>210,0</td> <td>-</td> <td>-</td> <td>203,0</td> <td></td> </tr> <tr> <td>88</td> <td>-</td> <td>-</td> <td>159,0</td> <td>202,0</td> <td>-</td> <td>-</td> <td>196,0</td> <td></td> </tr> <tr> <td>90</td> <td>-</td> <td>-</td> <td>-</td> <td>193,0</td> <td>-</td> <td>-</td> <td>189,0</td> <td></td> </tr> <tr> <td>94</td> <td>-</td> <td>-</td> <td>-</td> <td>177,0</td> <td>-</td> <td>-</td> <td>176,0</td> <td></td> </tr> <tr> <td>98</td> <td>-</td> <td>-</td> <td>-</td> <td>162,0</td> <td>162,0</td> <td>-</td> <td>162,0</td> <td></td> </tr> <tr> <td>100</td> <td>-</td> <td>-</td> <td>-</td> <td>156,0</td> <td>158,0</td> <td>-</td> <td>154,0</td> <td></td> </tr> <tr> <td>102</td> <td>-</td> <td>-</td> <td>-</td> <td>-</td> <td>153,0</td> <td>-</td> <td>146,0</td> <td></td> </tr> <tr> <td>106</td> <td>-</td> <td>-</td> <td>-</td> <td>-</td> <td>145,0</td> <td>-</td> <td>132,0</td> <td></td> </tr> <tr> <td>110</td> <td>-</td> <td>-</td> <td>-</td> <td>-</td> <td>138,0</td> <td>-</td> <td>118,0</td> <td></td> </tr> <tr> <td>114</td> <td>-</td> <td>-</td> <td>-</td> <td>-</td> <td>-</td> <td>107,0</td> <td>105,0</td> <td></td> </tr> <tr> <td>118</td> <td>-</td> <td>-</td> <td>-</td> <td>-</td> <td>-</td> <td>101,0</td> <td>95,0</td> <td></td> </tr> <tr> <td>119</td> <td>-</td> <td>-</td> <td>-</td> <td>-</td> <td>-</td> <td>100,0</td> <td>93,2</td> <td></td> </tr> <tr> <td>122</td> <td>-</td> <td>-</td> <td>-</td> <td>-</td> <td>-</td> <td>-</td> <td>88,0</td> <td></td> </tr> <tr> <td>126</td> <td>-</td> <td>-</td> <td>-</td> <td>-</td> <td>-</td> <td>-</td> <td>76,5</td> <td></td> </tr> </tbody> </table>												m	SWSL							SFSL	0 t	0 t - 640 t							85°	85°	75°	65°	55°	45°		30	-	277,0*	-	-	-	-	-	-	34	-	269,0*	-	-	-	-	-	-	36	146,0	288,0	-	-	-	-	282,0		38	137,0	287,0	-	-	-	-	282,0		42	122,0	282,0	-	-	-	-	282,0		46	109,0	276,0	-	-	-	-	282,0		50	98,0	270,0	-	-	-	-	282,0		54	88,5	264,0	-	-	-	-	282,0		58	80,0	244,0	-	-	-	-	274,0		60	76,0	232,0	295,0	-	-	-	269,0		62	72,5	220,0	293,0	-	-	-	265,0		66	65,0	200,0	267,0	-	-	-	257,0		70	58,0	183,0	240,0	-	-	-	248,0		74	52,0	162,0	217,0	-	-	-	240,0		78	47,0	139,0	198,0	-	-	-	232,0		80	-	-	189,0	230,0	-	-	225,5		82	-	-	181,0	223,0	-	-	219,0		86	-	-	166,0	210,0	-	-	203,0		88	-	-	159,0	202,0	-	-	196,0		90	-	-	-	193,0	-	-	189,0		94	-	-	-	177,0	-	-	176,0		98	-	-	-	162,0	162,0	-	162,0		100	-	-	-	156,0	158,0	-	154,0		102	-	-	-	-	153,0	-	146,0		106	-	-	-	-	145,0	-	132,0		110	-	-	-	-	138,0	-	118,0		114	-	-	-	-	-	107,0	105,0		118	-	-	-	-	-	101,0	95,0		119	-	-	-	-	-	100,0	93,2		122	-	-	-	-	-	-	88,0		126	-	-	-	-	-	-	76,5	
m	SWSL							SFSL																																																																																																																																																																																																																																																																																																																		
	0 t	0 t - 640 t																																																																																																																																																																																																																																																																																																																								
	85°	85°	75°	65°	55°	45°																																																																																																																																																																																																																																																																																																																				
30	-	277,0*	-	-	-	-	-	-																																																																																																																																																																																																																																																																																																																		
34	-	269,0*	-	-	-	-	-	-																																																																																																																																																																																																																																																																																																																		
36	146,0	288,0	-	-	-	-	282,0																																																																																																																																																																																																																																																																																																																			
38	137,0	287,0	-	-	-	-	282,0																																																																																																																																																																																																																																																																																																																			
42	122,0	282,0	-	-	-	-	282,0																																																																																																																																																																																																																																																																																																																			
46	109,0	276,0	-	-	-	-	282,0																																																																																																																																																																																																																																																																																																																			
50	98,0	270,0	-	-	-	-	282,0																																																																																																																																																																																																																																																																																																																			
54	88,5	264,0	-	-	-	-	282,0																																																																																																																																																																																																																																																																																																																			
58	80,0	244,0	-	-	-	-	274,0																																																																																																																																																																																																																																																																																																																			
60	76,0	232,0	295,0	-	-	-	269,0																																																																																																																																																																																																																																																																																																																			
62	72,5	220,0	293,0	-	-	-	265,0																																																																																																																																																																																																																																																																																																																			
66	65,0	200,0	267,0	-	-	-	257,0																																																																																																																																																																																																																																																																																																																			
70	58,0	183,0	240,0	-	-	-	248,0																																																																																																																																																																																																																																																																																																																			
74	52,0	162,0	217,0	-	-	-	240,0																																																																																																																																																																																																																																																																																																																			
78	47,0	139,0	198,0	-	-	-	232,0																																																																																																																																																																																																																																																																																																																			
80	-	-	189,0	230,0	-	-	225,5																																																																																																																																																																																																																																																																																																																			
82	-	-	181,0	223,0	-	-	219,0																																																																																																																																																																																																																																																																																																																			
86	-	-	166,0	210,0	-	-	203,0																																																																																																																																																																																																																																																																																																																			
88	-	-	159,0	202,0	-	-	196,0																																																																																																																																																																																																																																																																																																																			
90	-	-	-	193,0	-	-	189,0																																																																																																																																																																																																																																																																																																																			
94	-	-	-	177,0	-	-	176,0																																																																																																																																																																																																																																																																																																																			
98	-	-	-	162,0	162,0	-	162,0																																																																																																																																																																																																																																																																																																																			
100	-	-	-	156,0	158,0	-	154,0																																																																																																																																																																																																																																																																																																																			
102	-	-	-	-	153,0	-	146,0																																																																																																																																																																																																																																																																																																																			
106	-	-	-	-	145,0	-	132,0																																																																																																																																																																																																																																																																																																																			
110	-	-	-	-	138,0	-	118,0																																																																																																																																																																																																																																																																																																																			
114	-	-	-	-	-	107,0	105,0																																																																																																																																																																																																																																																																																																																			
118	-	-	-	-	-	101,0	95,0																																																																																																																																																																																																																																																																																																																			
119	-	-	-	-	-	100,0	93,2																																																																																																																																																																																																																																																																																																																			
122	-	-	-	-	-	-	88,0																																																																																																																																																																																																																																																																																																																			
126	-	-	-	-	-	-	76,5																																																																																																																																																																																																																																																																																																																			

6 m steps of luffing jib is standard · 6 m Stufung der Wippe ist Standard · Des paliers de 6 m sont de série pour la fléchette

Main boom angle 88°, 85°, 75°, 65°, 55° and 45°; capacities for intermediate boom positions are calculated by the crane control system IC-1  
 Hauptauslegerwinkel 88°, 85°, 75°, 65°, 55° und 45°; Traglasten für Zwischenstellungen des Hauptauslegers werden von der Kransteuerung IC-1 berechnet

Jarret de flèche principale 88°, 85°, 75°, 65°, 55° et 45° ; le système de commande de la grue IC-1 calcule les charges pour les positions intermédiaires de la flèche

\* Main boom angle 88° · Hauptauslegerwinkel 88° · Jarret de flèche principale 88°



295 t + 60 t ZB		19-30 m		10,5 m		9.8 m/s		360°		ISO																																																																																																																																																																																																																																																																																																																																														
66 m + 84 m						66 m + 96 m																																																																																																																																																																																																																																																																																																																																																		
<table border="1"> <thead> <tr> <th rowspan="3">m</th> <th colspan="6">SWSL</th> <th>SFSL</th> </tr> <tr> <th colspan="2">0 t</th> <th colspan="4">0 t - 640 t</th> <th></th> </tr> <tr> <th>85°</th> <th>85°</th> <th>75°</th> <th>65°</th> <th>55°</th> <th>45°</th> <th></th> </tr> </thead> <tbody> <tr><td>32</td><td>-</td><td>224,0*</td><td>-</td><td>-</td><td>-</td><td>-</td><td>-</td></tr> <tr><td>34</td><td>-</td><td>224,0*</td><td>-</td><td>-</td><td>-</td><td>-</td><td>-</td></tr> <tr><td>38</td><td>-</td><td>218,0*</td><td>-</td><td>-</td><td>-</td><td>-</td><td>-</td></tr> <tr><td>40</td><td>118,0</td><td>232,0</td><td>-</td><td>-</td><td>-</td><td>-</td><td>228,0</td></tr> <tr><td>42</td><td>111,0</td><td>232,0</td><td>-</td><td>-</td><td>-</td><td>-</td><td>228,0</td></tr> <tr><td>46</td><td>98,5</td><td>228,0</td><td>-</td><td>-</td><td>-</td><td>-</td><td>228,0</td></tr> <tr><td>50</td><td>88,0</td><td>225,0</td><td>-</td><td>-</td><td>-</td><td>-</td><td>228,0</td></tr> <tr><td>54</td><td>79,0</td><td>221,0</td><td>-</td><td>-</td><td>-</td><td>-</td><td>228,0</td></tr> <tr><td>58</td><td>70,5</td><td>217,0</td><td>-</td><td>-</td><td>-</td><td>-</td><td>228,0</td></tr> <tr><td>62</td><td>63,5</td><td>213,0</td><td>-</td><td>-</td><td>-</td><td>-</td><td>224,0</td></tr> <tr><td>66</td><td>57,0</td><td>194,0</td><td>232,0</td><td>-</td><td>-</td><td>-</td><td>219,0</td></tr> <tr><td>70</td><td>51,0</td><td>177,0</td><td>232,0</td><td>-</td><td>-</td><td>-</td><td>214,0</td></tr> <tr><td>74</td><td>45,3</td><td>161,0</td><td>211,0</td><td>-</td><td>-</td><td>-</td><td>209,0</td></tr> <tr><td>78</td><td>39,9</td><td>148,0</td><td>191,0</td><td>-</td><td>-</td><td>-</td><td>203,0</td></tr> <tr><td>82</td><td>35,2</td><td>135,0</td><td>174,0</td><td>-</td><td>-</td><td>-</td><td>198,0</td></tr> <tr><td>86</td><td>31,0</td><td>120,0</td><td>160,0</td><td>-</td><td>-</td><td>-</td><td>193,0</td></tr> <tr><td>88</td><td>29,1</td><td>112,0</td><td>153,0</td><td>195,0</td><td>-</td><td>-</td><td>189,5</td></tr> <tr><td>90</td><td>-</td><td>-</td><td>146,0</td><td>187,0</td><td>-</td><td>-</td><td>186,0</td></tr> <tr><td>94</td><td>-</td><td>-</td><td>135,0</td><td>170,0</td><td>-</td><td>-</td><td>173,0</td></tr> <tr><td>98</td><td>-</td><td>-</td><td>124,0</td><td>156,0</td><td>-</td><td>-</td><td>161,0</td></tr> <tr><td>100</td><td>-</td><td>-</td><td>119,0</td><td>149,0</td><td>-</td><td>-</td><td>155,5</td></tr> <tr><td>102</td><td>-</td><td>-</td><td>-</td><td>143,0</td><td>-</td><td>-</td><td>150,0</td></tr> <tr><td>106</td><td>-</td><td>-</td><td>-</td><td>132,0</td><td>-</td><td>-</td><td>137,0</td></tr> <tr><td>108</td><td>-</td><td>-</td><td>-</td><td>127,0</td><td>132,0</td><td>-</td><td>130,5</td></tr> <tr><td>110</td><td>-</td><td>-</td><td>-</td><td>122,0</td><td>128,0</td><td>-</td><td>124,0</td></tr> <tr><td>114</td><td>-</td><td>-</td><td>-</td><td>-</td><td>121,0</td><td>-</td><td>111,0</td></tr> <tr><td>118</td><td>-</td><td>-</td><td>-</td><td>-</td><td>115,0</td><td>-</td><td>100,0</td></tr> <tr><td>120</td><td>-</td><td>-</td><td>-</td><td>-</td><td>112,0</td><td>-</td><td>94,2</td></tr> <tr><td>122</td><td>-</td><td>-</td><td>-</td><td>-</td><td>-</td><td>-</td><td>88,5</td></tr> <tr><td>124</td><td>-</td><td>-</td><td>-</td><td>-</td><td>-</td><td>84,0</td><td>83,0</td></tr> <tr><td>126</td><td>-</td><td>-</td><td>-</td><td>-</td><td>-</td><td>81,5</td><td>78,5</td></tr> <tr><td>130</td><td>-</td><td>-</td><td>-</td><td>-</td><td>-</td><td>77,0</td><td>72,5</td></tr> <tr><td>134</td><td>-</td><td>-</td><td>-</td><td>-</td><td>-</td><td>-</td><td>64,0</td></tr> <tr><td>138</td><td>-</td><td>-</td><td>-</td><td>-</td><td>-</td><td>-</td><td>54,0</td></tr> </tbody> </table>											m	SWSL						SFSL	0 t		0 t - 640 t					85°	85°	75°	65°	55°	45°		32	-	224,0*	-	-	-	-	-	34	-	224,0*	-	-	-	-	-	38	-	218,0*	-	-	-	-	-	40	118,0	232,0	-	-	-	-	228,0	42	111,0	232,0	-	-	-	-	228,0	46	98,5	228,0	-	-	-	-	228,0	50	88,0	225,0	-	-	-	-	228,0	54	79,0	221,0	-	-	-	-	228,0	58	70,5	217,0	-	-	-	-	228,0	62	63,5	213,0	-	-	-	-	224,0	66	57,0	194,0	232,0	-	-	-	219,0	70	51,0	177,0	232,0	-	-	-	214,0	74	45,3	161,0	211,0	-	-	-	209,0	78	39,9	148,0	191,0	-	-	-	203,0	82	35,2	135,0	174,0	-	-	-	198,0	86	31,0	120,0	160,0	-	-	-	193,0	88	29,1	112,0	153,0	195,0	-	-	189,5	90	-	-	146,0	187,0	-	-	186,0	94	-	-	135,0	170,0	-	-	173,0	98	-	-	124,0	156,0	-	-	161,0	100	-	-	119,0	149,0	-	-	155,5	102	-	-	-	143,0	-	-	150,0	106	-	-	-	132,0	-	-	137,0	108	-	-	-	127,0	132,0	-	130,5	110	-	-	-	122,0	128,0	-	124,0	114	-	-	-	-	121,0	-	111,0	118	-	-	-	-	115,0	-	100,0	120	-	-	-	-	112,0	-	94,2	122	-	-	-	-	-	-	88,5	124	-	-	-	-	-	84,0	83,0	126	-	-	-	-	-	81,5	78,5	130	-	-	-	-	-	77,0	72,5	134	-	-	-	-	-	-	64,0	138	-	-	-	-	-	-	54,0																																								
m	SWSL						SFSL																																																																																																																																																																																																																																																																																																																																																	
	0 t		0 t - 640 t																																																																																																																																																																																																																																																																																																																																																					
	85°	85°	75°	65°	55°	45°																																																																																																																																																																																																																																																																																																																																																		
32	-	224,0*	-	-	-	-	-																																																																																																																																																																																																																																																																																																																																																	
34	-	224,0*	-	-	-	-	-																																																																																																																																																																																																																																																																																																																																																	
38	-	218,0*	-	-	-	-	-																																																																																																																																																																																																																																																																																																																																																	
40	118,0	232,0	-	-	-	-	228,0																																																																																																																																																																																																																																																																																																																																																	
42	111,0	232,0	-	-	-	-	228,0																																																																																																																																																																																																																																																																																																																																																	
46	98,5	228,0	-	-	-	-	228,0																																																																																																																																																																																																																																																																																																																																																	
50	88,0	225,0	-	-	-	-	228,0																																																																																																																																																																																																																																																																																																																																																	
54	79,0	221,0	-	-	-	-	228,0																																																																																																																																																																																																																																																																																																																																																	
58	70,5	217,0	-	-	-	-	228,0																																																																																																																																																																																																																																																																																																																																																	
62	63,5	213,0	-	-	-	-	224,0																																																																																																																																																																																																																																																																																																																																																	
66	57,0	194,0	232,0	-	-	-	219,0																																																																																																																																																																																																																																																																																																																																																	
70	51,0	177,0	232,0	-	-	-	214,0																																																																																																																																																																																																																																																																																																																																																	
74	45,3	161,0	211,0	-	-	-	209,0																																																																																																																																																																																																																																																																																																																																																	
78	39,9	148,0	191,0	-	-	-	203,0																																																																																																																																																																																																																																																																																																																																																	
82	35,2	135,0	174,0	-	-	-	198,0																																																																																																																																																																																																																																																																																																																																																	
86	31,0	120,0	160,0	-	-	-	193,0																																																																																																																																																																																																																																																																																																																																																	
88	29,1	112,0	153,0	195,0	-	-	189,5																																																																																																																																																																																																																																																																																																																																																	
90	-	-	146,0	187,0	-	-	186,0																																																																																																																																																																																																																																																																																																																																																	
94	-	-	135,0	170,0	-	-	173,0																																																																																																																																																																																																																																																																																																																																																	
98	-	-	124,0	156,0	-	-	161,0																																																																																																																																																																																																																																																																																																																																																	
100	-	-	119,0	149,0	-	-	155,5																																																																																																																																																																																																																																																																																																																																																	
102	-	-	-	143,0	-	-	150,0																																																																																																																																																																																																																																																																																																																																																	
106	-	-	-	132,0	-	-	137,0																																																																																																																																																																																																																																																																																																																																																	
108	-	-	-	127,0	132,0	-	130,5																																																																																																																																																																																																																																																																																																																																																	
110	-	-	-	122,0	128,0	-	124,0																																																																																																																																																																																																																																																																																																																																																	
114	-	-	-	-	121,0	-	111,0																																																																																																																																																																																																																																																																																																																																																	
118	-	-	-	-	115,0	-	100,0																																																																																																																																																																																																																																																																																																																																																	
120	-	-	-	-	112,0	-	94,2																																																																																																																																																																																																																																																																																																																																																	
122	-	-	-	-	-	-	88,5																																																																																																																																																																																																																																																																																																																																																	
124	-	-	-	-	-	84,0	83,0																																																																																																																																																																																																																																																																																																																																																	
126	-	-	-	-	-	81,5	78,5																																																																																																																																																																																																																																																																																																																																																	
130	-	-	-	-	-	77,0	72,5																																																																																																																																																																																																																																																																																																																																																	
134	-	-	-	-	-	-	64,0																																																																																																																																																																																																																																																																																																																																																	
138	-	-	-	-	-	-	54,0																																																																																																																																																																																																																																																																																																																																																	
<table border="1"> <thead> <tr> <th rowspan="3">m</th> <th colspan="6">SWSL</th> <th>SFSL</th> </tr> <tr> <th colspan="2">0 t</th> <th colspan="4">0 t - 640 t</th> <th></th> </tr> <tr> <th>85°</th> <th>85°</th> <th>75°</th> <th>65°</th> <th>55°</th> <th>45°</th> <th></th> </tr> </thead> <tbody> <tr><td>36</td><td>-</td><td>181,0*</td><td>-</td><td>-</td><td>-</td><td>-</td><td>-</td></tr> <tr><td>38</td><td>-</td><td>180,0*</td><td>-</td><td>-</td><td>-</td><td>-</td><td>-</td></tr> <tr><td>42</td><td>-</td><td>176,0*</td><td>-</td><td>-</td><td>-</td><td>-</td><td>-</td></tr> <tr><td>44</td><td>96,0</td><td>185,0</td><td>-</td><td>-</td><td>-</td><td>-</td><td>183,0</td></tr> <tr><td>46</td><td>90,5</td><td>185,0</td><td>-</td><td>-</td><td>-</td><td>-</td><td>183,0</td></tr> <tr><td>50</td><td>80,0</td><td>183,0</td><td>-</td><td>-</td><td>-</td><td>-</td><td>183,0</td></tr> <tr><td>54</td><td>71,5</td><td>180,0</td><td>-</td><td>-</td><td>-</td><td>-</td><td>183,0</td></tr> <tr><td>58</td><td>63,5</td><td>178,0</td><td>-</td><td>-</td><td>-</td><td>-</td><td>183,0</td></tr> <tr><td>62</td><td>56,5</td><td>175,0</td><td>-</td><td>-</td><td>-</td><td>-</td><td>183,0</td></tr> <tr><td>66</td><td>50,5</td><td>173,0</td><td>-</td><td>-</td><td>-</td><td>-</td><td>182,0</td></tr> <tr><td>70</td><td>45,1</td><td>170,0</td><td>-</td><td>-</td><td>-</td><td>-</td><td>178,0</td></tr> <tr><td>72</td><td>42,5</td><td>167,0</td><td>178,0</td><td>-</td><td>-</td><td>-</td><td>176,5</td></tr> <tr><td>74</td><td>40,1</td><td>159,0</td><td>178,0</td><td>-</td><td>-</td><td>-</td><td>175,0</td></tr> <tr><td>78</td><td>35,6</td><td>146,0</td><td>178,0</td><td>-</td><td>-</td><td>-</td><td>172,0</td></tr> <tr><td>82</td><td>31,4</td><td>134,0</td><td>173,0</td><td>-</td><td>-</td><td>-</td><td>169,0</td></tr> <tr><td>86</td><td>27,3</td><td>123,0</td><td>157,0</td><td>-</td><td>-</td><td>-</td><td>166,0</td></tr> <tr><td>90</td><td>23,5</td><td>113,5</td><td>144,0</td><td>-</td><td>-</td><td>-</td><td>162,0</td></tr> <tr><td>92</td><td>21,7</td><td>109,0</td><td>138,0</td><td>-</td><td>-</td><td>-</td><td>160,5</td></tr> <tr><td>94</td><td>20,0</td><td>103,7</td><td>132,0</td><td>-</td><td>-</td><td>-</td><td>159,0</td></tr> <tr><td>96</td><td>18,4</td><td>98,5</td><td>127,0</td><td>159,0</td><td>-</td><td>-</td><td>157,0</td></tr> <tr><td>98</td><td>16,9</td><td>92,0</td><td>122,0</td><td>154,0</td><td>-</td><td>-</td><td>155,0</td></tr> <tr><td>100</td><td>15,5</td><td>85,5</td><td>117,0</td><td>147,0</td><td>-</td><td>-</td><td>152,5</td></tr> <tr><td>102</td><td>-</td><td>-</td><td>112,0</td><td>141,0</td><td>-</td><td>-</td><td>150,0</td></tr> <tr><td>106</td><td>-</td><td>-</td><td>104,0</td><td>130,0</td><td>-</td><td>-</td><td>140,0</td></tr> <tr><td>110</td><td>-</td><td>-</td><td>96,5</td><td>119,0</td><td>-</td><td>-</td><td>131,0</td></tr> <tr><td>112</td><td>-</td><td>-</td><td>92,5</td><td>115,0</td><td>-</td><td>-</td><td>125,0</td></tr> <tr><td>114</td><td>-</td><td>-</td><td>-</td><td>110,0</td><td>-</td><td>-</td><td>119,0</td></tr> <tr><td>118</td><td>-</td><td>-</td><td>-</td><td>102,0</td><td>110,0</td><td>-</td><td>107,0</td></tr> <tr><td>122</td><td>-</td><td>-</td><td>-</td><td>94,5</td><td>104,0</td><td>-</td><td>97,0</td></tr> <tr><td>126</td><td>-</td><td>-</td><td>-</td><td>-</td><td>98,5</td><td>-</td><td>86,5</td></tr> <tr><td>130</td><td>-</td><td>-</td><td>-</td><td>-</td><td>93,5</td><td>-</td><td>76,5</td></tr> <tr><td>132</td><td>-</td><td>-</td><td>-</td><td>-</td><td>91,5</td><td>-</td><td>71,7</td></tr> <tr><td>134</td><td>-</td><td>-</td><td>-</td><td>-</td><td>-</td><td>-</td><td>67,0</td></tr> <tr><td>136</td><td>-</td><td>-</td><td>-</td><td>-</td><td>-</td><td>65,5</td><td>64,2</td></tr> <tr><td>138</td><td>-</td><td>-</td><td>-</td><td>-</td><td>-</td><td>64,0</td><td>61,5</td></tr> <tr><td>140</td><td>-</td><td>-</td><td>-</td><td>-</td><td>-</td><td>62,5</td><td>58,5</td></tr> <tr><td>142</td><td>-</td><td>-</td><td>-</td><td>-</td><td>-</td><td>-</td><td>55,5</td></tr> <tr><td>146</td><td>-</td><td>-</td><td>-</td><td>-</td><td>-</td><td>-</td><td>46,9</td></tr> <tr><td>150</td><td>-</td><td>-</td><td>-</td><td>-</td><td>-</td><td>-</td><td>37,9</td></tr> </tbody> </table>											m	SWSL						SFSL	0 t		0 t - 640 t					85°	85°	75°	65°	55°	45°		36	-	181,0*	-	-	-	-	-	38	-	180,0*	-	-	-	-	-	42	-	176,0*	-	-	-	-	-	44	96,0	185,0	-	-	-	-	183,0	46	90,5	185,0	-	-	-	-	183,0	50	80,0	183,0	-	-	-	-	183,0	54	71,5	180,0	-	-	-	-	183,0	58	63,5	178,0	-	-	-	-	183,0	62	56,5	175,0	-	-	-	-	183,0	66	50,5	173,0	-	-	-	-	182,0	70	45,1	170,0	-	-	-	-	178,0	72	42,5	167,0	178,0	-	-	-	176,5	74	40,1	159,0	178,0	-	-	-	175,0	78	35,6	146,0	178,0	-	-	-	172,0	82	31,4	134,0	173,0	-	-	-	169,0	86	27,3	123,0	157,0	-	-	-	166,0	90	23,5	113,5	144,0	-	-	-	162,0	92	21,7	109,0	138,0	-	-	-	160,5	94	20,0	103,7	132,0	-	-	-	159,0	96	18,4	98,5	127,0	159,0	-	-	157,0	98	16,9	92,0	122,0	154,0	-	-	155,0	100	15,5	85,5	117,0	147,0	-	-	152,5	102	-	-	112,0	141,0	-	-	150,0	106	-	-	104,0	130,0	-	-	140,0	110	-	-	96,5	119,0	-	-	131,0	112	-	-	92,5	115,0	-	-	125,0	114	-	-	-	110,0	-	-	119,0	118	-	-	-	102,0	110,0	-	107,0	122	-	-	-	94,5	104,0	-	97,0	126	-	-	-	-	98,5	-	86,5	130	-	-	-	-	93,5	-	76,5	132	-	-	-	-	91,5	-	71,7	134	-	-	-	-	-	-	67,0	136	-	-	-	-	-	65,5	64,2	138	-	-	-	-	-	64,0	61,5	140	-	-	-	-	-	62,5	58,5	142	-	-	-	-	-	-	55,5	146	-	-	-	-	-	-	46,9	150	-	-	-	-	-	-	37,9
m	SWSL						SFSL																																																																																																																																																																																																																																																																																																																																																	
	0 t		0 t - 640 t																																																																																																																																																																																																																																																																																																																																																					
	85°	85°	75°	65°	55°	45°																																																																																																																																																																																																																																																																																																																																																		
36	-	181,0*	-	-	-	-	-																																																																																																																																																																																																																																																																																																																																																	
38	-	180,0*	-	-	-	-	-																																																																																																																																																																																																																																																																																																																																																	
42	-	176,0*	-	-	-	-	-																																																																																																																																																																																																																																																																																																																																																	
44	96,0	185,0	-	-	-	-	183,0																																																																																																																																																																																																																																																																																																																																																	
46	90,5	185,0	-	-	-	-	183,0																																																																																																																																																																																																																																																																																																																																																	
50	80,0	183,0	-	-	-	-	183,0																																																																																																																																																																																																																																																																																																																																																	
54	71,5	180,0	-	-	-	-	183,0																																																																																																																																																																																																																																																																																																																																																	
58	63,5	178,0	-	-	-	-	183,0																																																																																																																																																																																																																																																																																																																																																	
62	56,5	175,0	-	-	-	-	183,0																																																																																																																																																																																																																																																																																																																																																	
66	50,5	173,0	-	-	-	-	182,0																																																																																																																																																																																																																																																																																																																																																	
70	45,1	170,0	-	-	-	-	178,0																																																																																																																																																																																																																																																																																																																																																	
72	42,5	167,0	178,0	-	-	-	176,5																																																																																																																																																																																																																																																																																																																																																	
74	40,1	159,0	178,0	-	-	-	175,0																																																																																																																																																																																																																																																																																																																																																	
78	35,6	146,0	178,0	-	-	-	172,0																																																																																																																																																																																																																																																																																																																																																	
82	31,4	134,0	173,0	-	-	-	169,0																																																																																																																																																																																																																																																																																																																																																	
86	27,3	123,0	157,0	-	-	-	166,0																																																																																																																																																																																																																																																																																																																																																	
90	23,5	113,5	144,0	-	-	-	162,0																																																																																																																																																																																																																																																																																																																																																	
92	21,7	109,0	138,0	-	-	-	160,5																																																																																																																																																																																																																																																																																																																																																	
94	20,0	103,7	132,0	-	-	-	159,0																																																																																																																																																																																																																																																																																																																																																	
96	18,4	98,5	127,0	159,0	-	-	157,0																																																																																																																																																																																																																																																																																																																																																	
98	16,9	92,0	122,0	154,0	-	-	155,0																																																																																																																																																																																																																																																																																																																																																	
100	15,5	85,5	117,0	147,0	-	-	152,5																																																																																																																																																																																																																																																																																																																																																	
102	-	-	112,0	141,0	-	-	150,0																																																																																																																																																																																																																																																																																																																																																	
106	-	-	104,0	130,0	-	-	140,0																																																																																																																																																																																																																																																																																																																																																	
110	-	-	96,5	119,0	-	-	131,0																																																																																																																																																																																																																																																																																																																																																	
112	-	-	92,5	115,0	-	-	125,0																																																																																																																																																																																																																																																																																																																																																	
114	-	-	-	110,0	-	-	119,0																																																																																																																																																																																																																																																																																																																																																	
118	-	-	-	102,0	110,0	-	107,0																																																																																																																																																																																																																																																																																																																																																	
122	-	-	-	94,5	104,0	-	97,0																																																																																																																																																																																																																																																																																																																																																	
126	-	-	-	-	98,5	-	86,5																																																																																																																																																																																																																																																																																																																																																	
130	-	-	-	-	93,5	-	76,5																																																																																																																																																																																																																																																																																																																																																	
132	-	-	-	-	91,5	-	71,7																																																																																																																																																																																																																																																																																																																																																	
134	-	-	-	-	-	-	67,0																																																																																																																																																																																																																																																																																																																																																	
136	-	-	-	-	-	65,5	64,2																																																																																																																																																																																																																																																																																																																																																	
138	-	-	-	-	-	64,0	61,5																																																																																																																																																																																																																																																																																																																																																	
140	-	-	-	-	-	62,5	58,5																																																																																																																																																																																																																																																																																																																																																	
142	-	-	-	-	-	-	55,5																																																																																																																																																																																																																																																																																																																																																	
146	-	-	-	-	-	-	46,9																																																																																																																																																																																																																																																																																																																																																	
150	-	-	-	-	-	-	37,9																																																																																																																																																																																																																																																																																																																																																	

6 m steps of luffing jib is standard · 6 m Stufung der Wippe ist Standard · Des paliers de 6 m sont de série pour la fléchette

Main boom angle 88°, 85°, 75°, 65°, 55° and 45°; capacities for intermediate boom positions are calculated by the crane control system IC-1  
 Hauptauslegerwinkel 88°, 85°, 75°, 65°, 55° und 45°; Traglasten für Zwischenstellungen des Hauptauslegers werden von der Kransteuerung IC-1 berechnet

Jarret de flèche principale 88°, 85°, 75°, 65°, 55° et 45° ; le système de commande de la grue IC-1 calcule les charges pour les positions intermédiaires de la flèche

\* Main boom angle 88° · Hauptauslegerwinkel 88° · Jarret de flèche principale 88°

295 t + 60 t ZB		19-30 m		10,5 m		9.8 m/s		360°		ISO		
66 m + 108 m						72 m + 36 m						
		SWSL					SFSL					
		0 t		0 t - 640 t								
		85°		85°		75°		65°		45°		
		m		t		t		t		t		
40	-	141,0*	-	-	-	-	-	-	-	-	-	
42	-	140,0*	-	-	-	-	-	-	-	-	-	
46	-	138,0*	-	-	-	-	-	-	-	-	-	
48	77,5	142,0	-	-	-	-	-	-	-	142,0	-	
50	72,5	142,0	-	-	-	-	-	-	-	142,0	-	
54	64,0	140,0	-	-	-	-	-	-	-	142,0	-	
58	56,5	139,0	-	-	-	-	-	-	-	141,0	-	
62	50,0	137,0	-	-	-	-	-	-	-	140,0	-	
66	44,0	135,0	-	-	-	-	-	-	-	138,0	-	
70	38,7	134,0	-	-	-	-	-	-	-	137,0	-	
74	33,8	132,0	-	-	-	-	-	-	-	135,0	-	
78	29,4	131,0	131,0	-	-	-	-	-	-	133,0	-	
82	25,4	127,0	131,0	-	-	-	-	-	-	131,0	-	
84	23,5	124,0	131,0	-	-	-	-	-	-	130,0	-	
86	21,7	119,0	131,0	-	-	-	-	-	-	129,0	-	
90	18,3	109,0	130,0	-	-	-	-	-	-	126,0	-	
94	14,9	100,2	128,0	-	-	-	-	-	-	124,0	-	
98	11,8	92,7	117,0	-	-	-	-	-	-	122,0	-	
100	10,3	89,0	112,0	-	-	-	-	-	-	121,0	-	
102	-	85,5	108,0	-	-	-	-	-	-	120,0	-	
104	-	82,0	103,0	114,0	-	-	-	-	-	119,0	-	
106	-	77,5	99,5	114,0	-	-	-	-	-	118,0	-	
110	-	68,0	92,0	114,0	-	-	-	-	-	115,0	-	
112	-	63,0	88,0	110,0	-	-	-	-	-	114,0	-	
114	-	-	84,5	105,0	-	-	-	-	-	113,0	-	
118	-	-	78,5	97,5	-	-	-	-	-	110,0	-	
122	-	-	72,5	90,0	-	-	-	-	-	100,0	-	
126	-	-	-	83,0	92,0	-	-	-	-	91,0	-	
130	-	-	-	77,0	86,5	-	-	-	-	81,5	-	
134	-	-	-	71,0	82,0	-	-	-	-	72,5	-	
138	-	-	-	-	77,5	-	-	-	-	63,5	-	
142	-	-	-	-	73,5	-	-	-	-	55,5	-	
144	-	-	-	-	71,5	-	-	-	-	52,2	-	
146	-	-	-	-	-	51,0	50,0	-	-	-	-	
150	-	-	-	-	-	48,7	45,8	-	-	-	-	
152	-	-	-	-	-	47,5	41,9	-	-	-	-	
154	-	-	-	-	-	-	38,1	-	-	-	-	
158	-	-	-	-	-	-	30,4	-	-	-	-	
162	-	-	-	-	-	-	22,5	-	-	-	-	

6 m steps of luffing jib is standard · 6 m Stufung der Wippe ist Standard · Des paliers de 6 m sont de série pour la fléchette

Main boom angle 88°, 85°, 75°, 65°, 55° and 45°; capacities for intermediate boom positions are calculated by the crane control system IC-1  
Hauptauslegerwinkel 88°, 85°, 75°, 65°, 55° und 45°; Traglasten für Zwischenstellungen des Hauptauslegers werden von der Kransteuerung IC-1 berechnet

Jarret de flèche principale 88°, 85°, 75°, 65°, 55° et 45° ; le système de commande de la grue IC-1 calcule les charges pour les positions intermédiaires de la flèche

\* Main boom angle 88° · Hauptauslegerwinkel 88° · Jarret de flèche principale 88°

295 t + 60 t ZB		19-30 m		10,5 m		9.8 m/s		360°		ISO		
72 m + 48 m						72 m + 60 m						
		SWSL					SFSL					
		0 t		0 t - 640 t								
		85°	85°	75°	65°	55°	45°					
m	t	t	t	t	t	t	t	t	t			
22	-	390,0*	-	-	-	-	-	-	-			
24	-	385,0*	-	-	-	-	-	-	-			
26	-	376,0*	-	-	-	-	-	-	-			
28	208,0	409,0	-	-	-	-	-	-	397,0			
30	194,0	405,0	-	-	-	-	-	-	397,0			
34	170,0	392,0	-	-	-	-	-	-	397,0			
38	151,0	378,0	-	-	-	-	-	-	397,0			
42	134,0	365,0	-	-	-	-	-	-	397,0			
46	120,0	326,0	-	-	-	-	-	-	392,0			
48	112,0	306,0	414,0	-	-	-	-	-	384,0			
50	105,0	288,0	414,0	-	-	-	-	-	375,0			
54	94,0	257,0	380,0	-	-	-	-	-	359,0			
58	-	-	331,0	-	-	-	-	-	345,0			
62	-	-	292,0	-	-	-	-	-	315,0			
66	-	-	261,0	-	-	-	-	-	288,0			
67	-	-	254,0	285,0	-	-	-	-	282,0			
68	-	-	247,0	280,0	-	-	-	-	276,0			
70	-	-	-	271,0	-	-	-	-	264,0			
74	-	-	-	254,0	-	-	-	-	244,0			
78	-	-	-	239,0	-	-	-	-	225,0			
80	-	-	-	232,0	-	-	-	-	216,5			
82	-	-	-	-	-	-	-	-	208,0			
83	-	-	-	-	206,0	-	-	-	204,2			
86	-	-	-	-	197,0	-	-	-	193,0			
90	-	-	-	-	187,0	-	-	-	174,0			
94	-	-	-	-	-	-	-	-	156,0			
97	-	-	-	-	-	-	-	144,0	143,2			
98	-	-	-	-	-	-	-	142,0	139,0			
100	-	-	-	-	-	-	-	138,0	130,5			
102	-	-	-	-	-	-	-	-	122,0			
106	-	-	-	-	-	-	-	-	109,0			
26	-	317,0*	-	-	-	-	-	-	-			
28	-	311,0*	-	-	-	-	-	-	-			
30	-	305,0*	-	-	-	-	-	-	-			
32	170,0	330,0	-	-	-	-	-	-	-	321,0		
34	159,0	328,0	-	-	-	-	-	-	-	321,0		
38	141,0	320,0	-	-	-	-	-	-	-	321,0		
42	126,0	311,0	-	-	-	-	-	-	-	321,0		
46	113,0	302,0	-	-	-	-	-	-	-	321,0		
50	101,0	293,0	-	-	-	-	-	-	-	321,0		
54	92,0	270,0	335,0	-	-	-	-	-	-	311,0		
58	83,0	243,0	333,0	-	-	-	-	-	-	301,0		
62	74,5	220,0	307,0	-	-	-	-	-	-	288,0		
66	67,0	193,0	274,0	-	-	-	-	-	-	279,0		
70	-	-	246,0	-	-	-	-	-	-	269,0		
74	-	-	223,0	251,0	-	-	-	-	-	249,0		
78	-	-	203,0	236,0	-	-	-	-	-	230,0		
82	-	-	-	222,0	-	-	-	-	-	213,0		
86	-	-	-	209,0	-	-	-	-	-	197,0		
90	-	-	-	198,0	-	-	-	-	-	183,0		
92	-	-	-	-	-	178,0	-	-	-	176,5		
94	-	-	-	-	-	173,0	-	-	-	170,0		
98	-	-	-	-	-	165,0	-	-	-	156,0		
102	-	-	-	-	-	157,0	-	-	-	140,0		
106	-	-	-	-	-	-	-	-	-	125,0		
108	-	-	-	-	-	-	-	120,0	118,0			
110	-	-	-	-	-	-	-	117,0	111,0			
111	-	-	-	-	-	-	-	115,0	107,6			
114	-	-	-	-	-	-	-	-	-	97,5		
118	-	-	-	-	-	-	-	-	-	89,5		

6 m steps of luffing jib is standard · 6 m Stufung der Wippe ist Standard · Des paliers de 6 m sont de série pour la fléchette

Main boom angle 88°, 85°, 75°, 65°, 55° and 45°; capacities for intermediate boom positions are calculated by the crane control system IC-1  
 Hauptauslegerwinkel 88°, 85°, 75°, 65°, 55° und 45°; Traglasten für Zwischenstellungen des Hauptauslegers werden von der Kransteuerung IC-1 berechnet

Jarret de flèche principale 88°, 85°, 75°, 65°, 55° et 45° ; le système de commande de la grue IC-1 calcule les charges pour les positions intermédiaires de la flèche

\* Main boom angle 88° · Hauptauslegerwinkel 88° · Jarret de flèche principale 88°

295 t + 60 t ZB		19-30 m		10,5 m		9.8 m/s		360°		ISO																																																																																																																																																																																																																																																																																																																																																																																																																																									
72 m + 72 m						72 m + 84 m																																																																																																																																																																																																																																																																																																																																																																																																																																													
<table border="1"> <thead> <tr> <th colspan="11">SWSL</th> <th>SFSL</th> </tr> <tr> <th colspan="11">0 t</th> <th>0 t - 640 t</th> </tr> <tr> <th colspan="11">85°</th> <th>85°</th> <th>75°</th> <th>65°</th> <th>55°</th> <th>45°</th> </tr> <tr> <th>m</th> <th>t</th> <th>t</th> <th>t</th> <th>t</th> <th>t</th> <th>t</th> <th>t</th> <th>t</th> <th>t</th> <th>t</th> <th>t</th> </tr> </thead> <tbody> <tr><td>30</td><td>-</td><td>257,0*</td><td>-</td><td>-</td><td>-</td><td>-</td><td>-</td><td>-</td><td>-</td><td>-</td><td>-</td></tr> <tr><td>34</td><td>-</td><td>249,0*</td><td>-</td><td>-</td><td>-</td><td>-</td><td>-</td><td>-</td><td>-</td><td>-</td><td>-</td></tr> <tr><td>36</td><td>140,0</td><td>266,0</td><td>-</td><td>-</td><td>-</td><td>-</td><td>-</td><td>-</td><td>-</td><td>260,0</td><td>-</td></tr> <tr><td>38</td><td>131,0</td><td>266,0</td><td>-</td><td>-</td><td>-</td><td>-</td><td>-</td><td>-</td><td>-</td><td>260,0</td><td>-</td></tr> <tr><td>42</td><td>117,0</td><td>261,0</td><td>-</td><td>-</td><td>-</td><td>-</td><td>-</td><td>-</td><td>-</td><td>260,0</td><td>-</td></tr> <tr><td>46</td><td>104,0</td><td>256,0</td><td>-</td><td>-</td><td>-</td><td>-</td><td>-</td><td>-</td><td>-</td><td>260,0</td><td>-</td></tr> <tr><td>50</td><td>94,0</td><td>250,0</td><td>-</td><td>-</td><td>-</td><td>-</td><td>-</td><td>-</td><td>-</td><td>260,0</td><td>-</td></tr> <tr><td>54</td><td>84,5</td><td>244,0</td><td>-</td><td>-</td><td>-</td><td>-</td><td>-</td><td>-</td><td>-</td><td>260,0</td><td>-</td></tr> <tr><td>58</td><td>76,5</td><td>238,0</td><td>-</td><td>-</td><td>-</td><td>-</td><td>-</td><td>-</td><td>-</td><td>256,0</td><td>-</td></tr> <tr><td>60</td><td>73,0</td><td>235,0</td><td>272,0</td><td>-</td><td>-</td><td>-</td><td>-</td><td>-</td><td>-</td><td>252,5</td><td>-</td></tr> <tr><td>62</td><td>69,5</td><td>224,0</td><td>272,0</td><td>-</td><td>-</td><td>-</td><td>-</td><td>-</td><td>-</td><td>249,0</td><td>-</td></tr> <tr><td>66</td><td>63,0</td><td>204,0</td><td>269,0</td><td>-</td><td>-</td><td>-</td><td>-</td><td>-</td><td>-</td><td>242,0</td><td>-</td></tr> <tr><td>70</td><td>56,5</td><td>186,0</td><td>251,0</td><td>-</td><td>-</td><td>-</td><td>-</td><td>-</td><td>-</td><td>234,0</td><td>-</td></tr> <tr><td>74</td><td>50,5</td><td>166,0</td><td>227,0</td><td>-</td><td>-</td><td>-</td><td>-</td><td>-</td><td>-</td><td>228,0</td><td>-</td></tr> <tr><td>78</td><td>45,6</td><td>143,0</td><td>206,0</td><td>-</td><td>-</td><td>-</td><td>-</td><td>-</td><td>-</td><td>221,0</td><td>-</td></tr> <tr><td>82</td><td>-</td><td>-</td><td>188,0</td><td>217,0</td><td>-</td><td>-</td><td>-</td><td>-</td><td>-</td><td>215,0</td><td>-</td></tr> <tr><td>86</td><td>-</td><td>-</td><td>172,0</td><td>204,0</td><td>-</td><td>-</td><td>-</td><td>-</td><td>-</td><td>199,0</td><td>-</td></tr> <tr><td>90</td><td>-</td><td>-</td><td>157,0</td><td>193,0</td><td>-</td><td>-</td><td>-</td><td>-</td><td>-</td><td>185,0</td><td>-</td></tr> <tr><td>94</td><td>-</td><td>-</td><td>-</td><td>183,0</td><td>-</td><td>-</td><td>-</td><td>-</td><td>-</td><td>172,0</td><td>-</td></tr> <tr><td>98</td><td>-</td><td>-</td><td>-</td><td>172,0</td><td>-</td><td>-</td><td>-</td><td>-</td><td>-</td><td>160,0</td><td>-</td></tr> <tr><td>102</td><td>-</td><td>-</td><td>-</td><td>158,0</td><td>151,0</td><td>-</td><td>-</td><td>-</td><td>-</td><td>149,0</td><td>-</td></tr> <tr><td>106</td><td>-</td><td>-</td><td>-</td><td>-</td><td>144,0</td><td>-</td><td>-</td><td>-</td><td>-</td><td>137,0</td><td>-</td></tr> <tr><td>110</td><td>-</td><td>-</td><td>-</td><td>-</td><td>137,0</td><td>-</td><td>-</td><td>-</td><td>-</td><td>123,0</td><td>-</td></tr> <tr><td>112</td><td>-</td><td>-</td><td>-</td><td>-</td><td>133,0</td><td>-</td><td>-</td><td>-</td><td>-</td><td>116,5</td><td>-</td></tr> <tr><td>114</td><td>-</td><td>-</td><td>-</td><td>-</td><td>-</td><td>-</td><td>-</td><td>-</td><td>-</td><td>110,0</td><td>-</td></tr> <tr><td>118</td><td>-</td><td>-</td><td>-</td><td>-</td><td>-</td><td>-</td><td>-</td><td>-</td><td>99,5</td><td>98,5</td><td>-</td></tr> <tr><td>122</td><td>-</td><td>-</td><td>-</td><td>-</td><td>-</td><td>-</td><td>-</td><td>-</td><td>94,5</td><td>86,5</td><td>-</td></tr> <tr><td>126</td><td>-</td><td>-</td><td>-</td><td>-</td><td>-</td><td>-</td><td>-</td><td>-</td><td>-</td><td>77,5</td><td>-</td></tr> <tr><td>130</td><td>-</td><td>-</td><td>-</td><td>-</td><td>-</td><td>-</td><td>-</td><td>-</td><td>-</td><td>71,0</td><td>-</td></tr> </tbody> </table>												SWSL											SFSL	0 t											0 t - 640 t	85°											85°	75°	65°	55°	45°	m	t	t	t	t	t	t	t	t	t	t	t	30	-	257,0*	-	-	-	-	-	-	-	-	-	34	-	249,0*	-	-	-	-	-	-	-	-	-	36	140,0	266,0	-	-	-	-	-	-	-	260,0	-	38	131,0	266,0	-	-	-	-	-	-	-	260,0	-	42	117,0	261,0	-	-	-	-	-	-	-	260,0	-	46	104,0	256,0	-	-	-	-	-	-	-	260,0	-	50	94,0	250,0	-	-	-	-	-	-	-	260,0	-	54	84,5	244,0	-	-	-	-	-	-	-	260,0	-	58	76,5	238,0	-	-	-	-	-	-	-	256,0	-	60	73,0	235,0	272,0	-	-	-	-	-	-	252,5	-	62	69,5	224,0	272,0	-	-	-	-	-	-	249,0	-	66	63,0	204,0	269,0	-	-	-	-	-	-	242,0	-	70	56,5	186,0	251,0	-	-	-	-	-	-	234,0	-	74	50,5	166,0	227,0	-	-	-	-	-	-	228,0	-	78	45,6	143,0	206,0	-	-	-	-	-	-	221,0	-	82	-	-	188,0	217,0	-	-	-	-	-	215,0	-	86	-	-	172,0	204,0	-	-	-	-	-	199,0	-	90	-	-	157,0	193,0	-	-	-	-	-	185,0	-	94	-	-	-	183,0	-	-	-	-	-	172,0	-	98	-	-	-	172,0	-	-	-	-	-	160,0	-	102	-	-	-	158,0	151,0	-	-	-	-	149,0	-	106	-	-	-	-	144,0	-	-	-	-	137,0	-	110	-	-	-	-	137,0	-	-	-	-	123,0	-	112	-	-	-	-	133,0	-	-	-	-	116,5	-	114	-	-	-	-	-	-	-	-	-	110,0	-	118	-	-	-	-	-	-	-	-	99,5	98,5	-	122	-	-	-	-	-	-	-	-	94,5	86,5	-	126	-	-	-	-	-	-	-	-	-	77,5	-	130	-	-	-	-	-	-	-	-	-	71,0	-																								
SWSL											SFSL																																																																																																																																																																																																																																																																																																																																																																																																																																								
0 t											0 t - 640 t																																																																																																																																																																																																																																																																																																																																																																																																																																								
85°											85°	75°	65°	55°	45°																																																																																																																																																																																																																																																																																																																																																																																																																																				
m	t	t	t	t	t	t	t	t	t	t	t																																																																																																																																																																																																																																																																																																																																																																																																																																								
30	-	257,0*	-	-	-	-	-	-	-	-	-																																																																																																																																																																																																																																																																																																																																																																																																																																								
34	-	249,0*	-	-	-	-	-	-	-	-	-																																																																																																																																																																																																																																																																																																																																																																																																																																								
36	140,0	266,0	-	-	-	-	-	-	-	260,0	-																																																																																																																																																																																																																																																																																																																																																																																																																																								
38	131,0	266,0	-	-	-	-	-	-	-	260,0	-																																																																																																																																																																																																																																																																																																																																																																																																																																								
42	117,0	261,0	-	-	-	-	-	-	-	260,0	-																																																																																																																																																																																																																																																																																																																																																																																																																																								
46	104,0	256,0	-	-	-	-	-	-	-	260,0	-																																																																																																																																																																																																																																																																																																																																																																																																																																								
50	94,0	250,0	-	-	-	-	-	-	-	260,0	-																																																																																																																																																																																																																																																																																																																																																																																																																																								
54	84,5	244,0	-	-	-	-	-	-	-	260,0	-																																																																																																																																																																																																																																																																																																																																																																																																																																								
58	76,5	238,0	-	-	-	-	-	-	-	256,0	-																																																																																																																																																																																																																																																																																																																																																																																																																																								
60	73,0	235,0	272,0	-	-	-	-	-	-	252,5	-																																																																																																																																																																																																																																																																																																																																																																																																																																								
62	69,5	224,0	272,0	-	-	-	-	-	-	249,0	-																																																																																																																																																																																																																																																																																																																																																																																																																																								
66	63,0	204,0	269,0	-	-	-	-	-	-	242,0	-																																																																																																																																																																																																																																																																																																																																																																																																																																								
70	56,5	186,0	251,0	-	-	-	-	-	-	234,0	-																																																																																																																																																																																																																																																																																																																																																																																																																																								
74	50,5	166,0	227,0	-	-	-	-	-	-	228,0	-																																																																																																																																																																																																																																																																																																																																																																																																																																								
78	45,6	143,0	206,0	-	-	-	-	-	-	221,0	-																																																																																																																																																																																																																																																																																																																																																																																																																																								
82	-	-	188,0	217,0	-	-	-	-	-	215,0	-																																																																																																																																																																																																																																																																																																																																																																																																																																								
86	-	-	172,0	204,0	-	-	-	-	-	199,0	-																																																																																																																																																																																																																																																																																																																																																																																																																																								
90	-	-	157,0	193,0	-	-	-	-	-	185,0	-																																																																																																																																																																																																																																																																																																																																																																																																																																								
94	-	-	-	183,0	-	-	-	-	-	172,0	-																																																																																																																																																																																																																																																																																																																																																																																																																																								
98	-	-	-	172,0	-	-	-	-	-	160,0	-																																																																																																																																																																																																																																																																																																																																																																																																																																								
102	-	-	-	158,0	151,0	-	-	-	-	149,0	-																																																																																																																																																																																																																																																																																																																																																																																																																																								
106	-	-	-	-	144,0	-	-	-	-	137,0	-																																																																																																																																																																																																																																																																																																																																																																																																																																								
110	-	-	-	-	137,0	-	-	-	-	123,0	-																																																																																																																																																																																																																																																																																																																																																																																																																																								
112	-	-	-	-	133,0	-	-	-	-	116,5	-																																																																																																																																																																																																																																																																																																																																																																																																																																								
114	-	-	-	-	-	-	-	-	-	110,0	-																																																																																																																																																																																																																																																																																																																																																																																																																																								
118	-	-	-	-	-	-	-	-	99,5	98,5	-																																																																																																																																																																																																																																																																																																																																																																																																																																								
122	-	-	-	-	-	-	-	-	94,5	86,5	-																																																																																																																																																																																																																																																																																																																																																																																																																																								
126	-	-	-	-	-	-	-	-	-	77,5	-																																																																																																																																																																																																																																																																																																																																																																																																																																								
130	-	-	-	-	-	-	-	-	-	71,0	-																																																																																																																																																																																																																																																																																																																																																																																																																																								
<table border="1"> <thead> <tr> <th colspan="11">SWSL</th> <th>SFSL</th> </tr> <tr> <th colspan="11">0 t</th> <th>0 t - 640 t</th> </tr> <tr> <th colspan="11">85°</th> <th>85°</th> <th>75°</th> <th>65°</th> <th>55°</th> <th>45°</th> </tr> <tr> <th>m</th> <th>t</th> <th>t</th> <th>t</th> <th>t</th> <th>t</th> <th>t</th> <th>t</th> <th>t</th> <th>t</th> <th>t</th> <th>t</th> </tr> </thead> <tbody> <tr><td>34</td><td>-</td><td>208,0*</td><td>-</td><td>-</td><td>-</td><td>-</td><td>-</td><td>-</td><td>-</td><td>-</td><td>-</td></tr> <tr><td>38</td><td>-</td><td>202,0*</td><td>-</td><td>-</td><td>-</td><td>-</td><td>-</td><td>-</td><td>-</td><td>-</td><td>-</td></tr> <tr><td>42</td><td>106,0</td><td>216,0</td><td>-</td><td>-</td><td>-</td><td>-</td><td>-</td><td>-</td><td>-</td><td>211,0</td><td>-</td></tr> <tr><td>46</td><td>94,0</td><td>212,0</td><td>-</td><td>-</td><td>-</td><td>-</td><td>-</td><td>-</td><td>-</td><td>211,0</td><td>-</td></tr> <tr><td>50</td><td>84,0</td><td>208,0</td><td>-</td><td>-</td><td>-</td><td>-</td><td>-</td><td>-</td><td>-</td><td>211,0</td><td>-</td></tr> <tr><td>54</td><td>75,0</td><td>205,0</td><td>-</td><td>-</td><td>-</td><td>-</td><td>-</td><td>-</td><td>-</td><td>211,0</td><td>-</td></tr> <tr><td>58</td><td>67,0</td><td>201,0</td><td>-</td><td>-</td><td>-</td><td>-</td><td>-</td><td>-</td><td>-</td><td>211,0</td><td>-</td></tr> <tr><td>62</td><td>60,5</td><td>197,0</td><td>-</td><td>-</td><td>-</td><td>-</td><td>-</td><td>-</td><td>-</td><td>210,0</td><td>-</td></tr> <tr><td>66</td><td>54,0</td><td>193,0</td><td>216,0</td><td>-</td><td>-</td><td>-</td><td>-</td><td>-</td><td>-</td><td>206,0</td><td>-</td></tr> <tr><td>70</td><td>48,8</td><td>179,0</td><td>216,0</td><td>-</td><td>-</td><td>-</td><td>-</td><td>-</td><td>-</td><td>202,0</td><td>-</td></tr> <tr><td>74</td><td>43,8</td><td>164,0</td><td>216,0</td><td>-</td><td>-</td><td>-</td><td>-</td><td>-</td><td>-</td><td>198,0</td><td>-</td></tr> <tr><td>78</td><td>38,5</td><td>150,0</td><td>200,0</td><td>-</td><td>-</td><td>-</td><td>-</td><td>-</td><td>-</td><td>194,0</td><td>-</td></tr> <tr><td>82</td><td>33,8</td><td>137,5</td><td>182,0</td><td>-</td><td>-</td><td>-</td><td>-</td><td>-</td><td>-</td><td>188,0</td><td>-</td></tr> <tr><td>86</td><td>29,7</td><td>123,0</td><td>166,0</td><td>-</td><td>-</td><td>-</td><td>-</td><td>-</td><td>-</td><td>183,0</td><td>-</td></tr> <tr><td>88</td><td>27,8</td><td>115,0</td><td>159,0</td><td>-</td><td>-</td><td>-</td><td>-</td><td>-</td><td>-</td><td>181,0</td><td>-</td></tr> <tr><td>90</td><td>-</td><td>-</td><td>152,0</td><td>184,0</td><td>-</td><td>-</td><td>-</td><td>-</td><td>-</td><td>179,0</td><td>-</td></tr> <tr><td>94</td><td>-</td><td>-</td><td>140,0</td><td>174,0</td><td>-</td><td>-</td><td>-</td><td>-</td><td>-</td><td>169,0</td><td>-</td></tr> <tr><td>98</td><td>-</td><td>-</td><td>129,0</td><td>165,0</td><td>-</td><td>-</td><td>-</td><td>-</td><td>-</td><td>157,0</td><td>-</td></tr> <tr><td>102</td><td>-</td><td>-</td><td>118,0</td><td>152,0</td><td>-</td><td>-</td><td>-</td><td>-</td><td>-</td><td>146,0</td><td>-</td></tr> <tr><td>106</td><td>-</td><td>-</td><td>-</td><td>140,0</td><td>-</td><td>-</td><td>-</td><td>-</td><td>-</td><td>136,0</td><td>-</td></tr> <tr><td>110</td><td>-</td><td>-</td><td>-</td><td>129,0</td><td>-</td><td>-</td><td>-</td><td>-</td><td>-</td><td>127,0</td><td>-</td></tr> <tr><td>112</td><td>-</td><td>-</td><td>-</td><td>124,0</td><td>123,0</td><td>-</td><td>-</td><td>-</td><td>-</td><td>121,0</td><td>-</td></tr> <tr><td>114</td><td>-</td><td>-</td><td>-</td><td>119,0</td><td>120,0</td><td>-</td><td>-</td><td>-</td><td>-</td><td>115,0</td><td>-</td></tr> <tr><td>118</td><td>-</td><td>-</td><td>-</td><td>-</td><td>114,0</td><td>-</td><td>-</td><td>-</td><td>-</td><td>103,0</td><td>-</td></tr> <tr><td>122</td><td>-</td><td>-</td><td>-</td><td>-</td><td>108,0</td><td>-</td><td>-</td><td>-</td><td>-</td><td>92,5</td><td>-</td></tr> <tr><td>124</td><td>-</td><td>-</td><td>-</td><td>-</td><td>105,0</td><td>-</td><td>-</td><td>-</td><td>-</td><td>87,2</td><td>-</td></tr> <tr><td>126</td><td>-</td><td>-</td><td>-</td><td>-</td><td>-</td><td>-</td><td>-</td><td>-</td><td>-</td><td>82,0</td><td>-</td></tr> <tr><td>130</td><td>-</td><td>-</td><td>-</td><td>-</td><td>-</td><td>-</td><td>-</td><td>-</td><td>75,0</td><td>71,5</td><td>-</td></tr> <tr><td>134</td><td>-</td><td>-</td><td>-</td><td>-</td><td>-</td><td>-</td><td>-</td><td>-</td><td>71,0</td><td>62,5</td><td>-</td></tr> <tr><td>138</td><td>-</td><td>-</td><td>-</td><td>-</td><td>-</td><td>-</td><td>-</td><td>-</td><td>-</td><td>57,5</td><td>-</td></tr> <tr><td>142</td><td>-</td><td>-</td><td>-</td><td>-</td><td>-</td><td>-</td><td>-</td><td>-</td><td>-</td><td>49,6</td><td>-</td></tr> </tbody> </table>												SWSL											SFSL	0 t											0 t - 640 t	85°											85°	75°	65°	55°	45°	m	t	t	t	t	t	t	t	t	t	t	t	34	-	208,0*	-	-	-	-	-	-	-	-	-	38	-	202,0*	-	-	-	-	-	-	-	-	-	42	106,0	216,0	-	-	-	-	-	-	-	211,0	-	46	94,0	212,0	-	-	-	-	-	-	-	211,0	-	50	84,0	208,0	-	-	-	-	-	-	-	211,0	-	54	75,0	205,0	-	-	-	-	-	-	-	211,0	-	58	67,0	201,0	-	-	-	-	-	-	-	211,0	-	62	60,5	197,0	-	-	-	-	-	-	-	210,0	-	66	54,0	193,0	216,0	-	-	-	-	-	-	206,0	-	70	48,8	179,0	216,0	-	-	-	-	-	-	202,0	-	74	43,8	164,0	216,0	-	-	-	-	-	-	198,0	-	78	38,5	150,0	200,0	-	-	-	-	-	-	194,0	-	82	33,8	137,5	182,0	-	-	-	-	-	-	188,0	-	86	29,7	123,0	166,0	-	-	-	-	-	-	183,0	-	88	27,8	115,0	159,0	-	-	-	-	-	-	181,0	-	90	-	-	152,0	184,0	-	-	-	-	-	179,0	-	94	-	-	140,0	174,0	-	-	-	-	-	169,0	-	98	-	-	129,0	165,0	-	-	-	-	-	157,0	-	102	-	-	118,0	152,0	-	-	-	-	-	146,0	-	106	-	-	-	140,0	-	-	-	-	-	136,0	-	110	-	-	-	129,0	-	-	-	-	-	127,0	-	112	-	-	-	124,0	123,0	-	-	-	-	121,0	-	114	-	-	-	119,0	120,0	-	-	-	-	115,0	-	118	-	-	-	-	114,0	-	-	-	-	103,0	-	122	-	-	-	-	108,0	-	-	-	-	92,5	-	124	-	-	-	-	105,0	-	-	-	-	87,2	-	126	-	-	-	-	-	-	-	-	-	82,0	-	130	-	-	-	-	-	-	-	-	75,0	71,5	-	134	-	-	-	-	-	-	-	-	71,0	62,5	-	138	-	-	-	-	-	-	-	-	-	57,5	-	142	-	-	-	-	-	-	-	-	-	49,6	-
SWSL											SFSL																																																																																																																																																																																																																																																																																																																																																																																																																																								
0 t											0 t - 640 t																																																																																																																																																																																																																																																																																																																																																																																																																																								
85°											85°	75°	65°	55°	45°																																																																																																																																																																																																																																																																																																																																																																																																																																				
m	t	t	t	t	t	t	t	t	t	t	t																																																																																																																																																																																																																																																																																																																																																																																																																																								
34	-	208,0*	-	-	-	-	-	-	-	-	-																																																																																																																																																																																																																																																																																																																																																																																																																																								
38	-	202,0*	-	-	-	-	-	-	-	-	-																																																																																																																																																																																																																																																																																																																																																																																																																																								
42	106,0	216,0	-	-	-	-	-	-	-	211,0	-																																																																																																																																																																																																																																																																																																																																																																																																																																								
46	94,0	212,0	-	-	-	-	-	-	-	211,0	-																																																																																																																																																																																																																																																																																																																																																																																																																																								
50	84,0	208,0	-	-	-	-	-	-	-	211,0	-																																																																																																																																																																																																																																																																																																																																																																																																																																								
54	75,0	205,0	-	-	-	-	-	-	-	211,0	-																																																																																																																																																																																																																																																																																																																																																																																																																																								
58	67,0	201,0	-	-	-	-	-	-	-	211,0	-																																																																																																																																																																																																																																																																																																																																																																																																																																								
62	60,5	197,0	-	-	-	-	-	-	-	210,0	-																																																																																																																																																																																																																																																																																																																																																																																																																																								
66	54,0	193,0	216,0	-	-	-	-	-	-	206,0	-																																																																																																																																																																																																																																																																																																																																																																																																																																								
70	48,8	179,0	216,0	-	-	-	-	-	-	202,0	-																																																																																																																																																																																																																																																																																																																																																																																																																																								
74	43,8	164,0	216,0	-	-	-	-	-	-	198,0	-																																																																																																																																																																																																																																																																																																																																																																																																																																								
78	38,5	150,0	200,0	-	-	-	-	-	-	194,0	-																																																																																																																																																																																																																																																																																																																																																																																																																																								
82	33,8	137,5	182,0	-	-	-	-	-	-	188,0	-																																																																																																																																																																																																																																																																																																																																																																																																																																								
86	29,7	123,0	166,0	-	-	-	-	-	-	183,0	-																																																																																																																																																																																																																																																																																																																																																																																																																																								
88	27,8	115,0	159,0	-	-	-	-	-	-	181,0	-																																																																																																																																																																																																																																																																																																																																																																																																																																								
90	-	-	152,0	184,0	-	-	-	-	-	179,0	-																																																																																																																																																																																																																																																																																																																																																																																																																																								
94	-	-	140,0	174,0	-	-	-	-	-	169,0	-																																																																																																																																																																																																																																																																																																																																																																																																																																								
98	-	-	129,0	165,0	-	-	-	-	-	157,0	-																																																																																																																																																																																																																																																																																																																																																																																																																																								
102	-	-	118,0	152,0	-	-	-	-	-	146,0	-																																																																																																																																																																																																																																																																																																																																																																																																																																								
106	-	-	-	140,0	-	-	-	-	-	136,0	-																																																																																																																																																																																																																																																																																																																																																																																																																																								
110	-	-	-	129,0	-	-	-	-	-	127,0	-																																																																																																																																																																																																																																																																																																																																																																																																																																								
112	-	-	-	124,0	123,0	-	-	-	-	121,0	-																																																																																																																																																																																																																																																																																																																																																																																																																																								
114	-	-	-	119,0	120,0	-	-	-	-	115,0	-																																																																																																																																																																																																																																																																																																																																																																																																																																								
118	-	-	-	-	114,0	-	-	-	-	103,0	-																																																																																																																																																																																																																																																																																																																																																																																																																																								
122	-	-	-	-	108,0	-	-	-	-	92,5	-																																																																																																																																																																																																																																																																																																																																																																																																																																								
124	-	-	-	-	105,0	-	-	-	-	87,2	-																																																																																																																																																																																																																																																																																																																																																																																																																																								
126	-	-	-	-	-	-	-	-	-	82,0	-																																																																																																																																																																																																																																																																																																																																																																																																																																								
130	-	-	-	-	-	-	-	-	75,0	71,5	-																																																																																																																																																																																																																																																																																																																																																																																																																																								
134	-	-	-	-	-	-	-	-	71,0	62,5	-																																																																																																																																																																																																																																																																																																																																																																																																																																								
138	-	-	-	-	-	-	-	-	-	57,5	-																																																																																																																																																																																																																																																																																																																																																																																																																																								
142	-	-	-	-	-	-	-	-	-	49,6	-																																																																																																																																																																																																																																																																																																																																																																																																																																								

6 m steps of luffing jib is standard · 6 m Stufung der Wippe ist Standard · Des paliers de 6 m sont de série pour la fléchette

Main boom angle 88°, 85°, 75°, 65°, 55° and 45°; capacities for intermediate boom positions are calculated by the crane control system IC-1  
 Hauptauslegerwinkel 88°, 85°, 75°, 65°, 55° und 45°; Traglasten für Zwischenstellungen des Hauptauslegers werden von der Kransteuerung IC-1 berechnet

Jarret de flèche principale 88°, 85°, 75°, 65°, 55° et 45° ; le système de commande de la grue IC-1 calcule les charges pour les positions intermédiaires de la flèche

\* Main boom angle 88° · Hauptauslegerwinkel 88° · Jarret de flèche principale 88°

295 t + 60 t ZB		19-30 m		10,5 m		9.8 m/s		360°		ISO																																																																																																																																																																																																																																																																																																																																																																																																																																																																																																																																																	
72 m + 96 m						72 m + 108 m																																																																																																																																																																																																																																																																																																																																																																																																																																																																																																																																																					
<table border="1"> <thead> <tr> <th colspan="10">SWSL</th> <th colspan="2">SFSL</th> </tr> <tr> <th colspan="2">0 t</th> <th colspan="8">0 t - 640 t</th> <th colspan="2"></th> </tr> <tr> <th></th> <th>85°</th> <th>85°</th> <th>75°</th> <th>65°</th> <th>55°</th> <th>45°</th> <th></th> <th></th> <th></th> <th></th> <th></th> </tr> <tr> <th>m</th> <th>t</th> <th>t</th> <th>t</th> <th>t</th> <th>t</th> <th>t</th> <th>t</th> <th>t</th> <th>t</th> <th>t</th> <th>t</th> </tr> </thead> <tbody> <tr><td>36</td><td>-</td><td>167,0*</td><td>-</td><td>-</td><td>-</td><td>-</td><td>-</td><td>-</td><td>-</td><td>-</td><td>-</td></tr> <tr><td>38</td><td>-</td><td>167,0*</td><td>-</td><td>-</td><td>-</td><td>-</td><td>-</td><td>-</td><td>-</td><td>-</td><td>-</td></tr> <tr><td>42</td><td>-</td><td>164,0*</td><td>-</td><td>-</td><td>-</td><td>-</td><td>-</td><td>-</td><td>-</td><td>-</td><td>-</td></tr> <tr><td>46</td><td>86,0</td><td>173,0</td><td>-</td><td>-</td><td>-</td><td>-</td><td>-</td><td>-</td><td>-</td><td>170,0</td><td>-</td></tr> <tr><td>50</td><td>76,0</td><td>170,0</td><td>-</td><td>-</td><td>-</td><td>-</td><td>-</td><td>-</td><td>-</td><td>170,0</td><td>-</td></tr> <tr><td>54</td><td>67,5</td><td>168,0</td><td>-</td><td>-</td><td>-</td><td>-</td><td>-</td><td>-</td><td>-</td><td>170,0</td><td>-</td></tr> <tr><td>58</td><td>60,0</td><td>166,0</td><td>-</td><td>-</td><td>-</td><td>-</td><td>-</td><td>-</td><td>-</td><td>170,0</td><td>-</td></tr> <tr><td>62</td><td>53,5</td><td>163,0</td><td>-</td><td>-</td><td>-</td><td>-</td><td>-</td><td>-</td><td>-</td><td>170,0</td><td>-</td></tr> <tr><td>66</td><td>47,6</td><td>161,0</td><td>-</td><td>-</td><td>-</td><td>-</td><td>-</td><td>-</td><td>-</td><td>170,0</td><td>-</td></tr> <tr><td>70</td><td>42,2</td><td>158,0</td><td>-</td><td>-</td><td>-</td><td>-</td><td>-</td><td>-</td><td>-</td><td>167,0</td><td>-</td></tr> <tr><td>72</td><td>39,8</td><td>157,0</td><td>168,0</td><td>-</td><td>-</td><td>-</td><td>-</td><td>-</td><td>-</td><td>166,0</td><td>-</td></tr> <tr><td>74</td><td>37,4</td><td>156,0</td><td>168,0</td><td>-</td><td>-</td><td>-</td><td>-</td><td>-</td><td>-</td><td>165,0</td><td>-</td></tr> <tr><td>78</td><td>33,0</td><td>148,0</td><td>168,0</td><td>-</td><td>-</td><td>-</td><td>-</td><td>-</td><td>-</td><td>162,0</td><td>-</td></tr> <tr><td>82</td><td>29,0</td><td>136,0</td><td>168,0</td><td>-</td><td>-</td><td>-</td><td>-</td><td>-</td><td>-</td><td>159,0</td><td>-</td></tr> <tr><td>86</td><td>25,3</td><td>125,0</td><td>164,0</td><td>-</td><td>-</td><td>-</td><td>-</td><td>-</td><td>-</td><td>157,0</td><td>-</td></tr> <tr><td>88</td><td>23,6</td><td>120,0</td><td>157,0</td><td>-</td><td>-</td><td>-</td><td>-</td><td>-</td><td>-</td><td>155,0</td><td>-</td></tr> <tr><td>90</td><td>22,0</td><td>115,5</td><td>150,0</td><td>-</td><td>-</td><td>-</td><td>-</td><td>-</td><td>-</td><td>153,0</td><td>-</td></tr> <tr><td>94</td><td>18,8</td><td>105,5</td><td>138,0</td><td>-</td><td>-</td><td>-</td><td>-</td><td>-</td><td>-</td><td>150,0</td><td>-</td></tr> <tr><td>98</td><td>15,8</td><td>94,0</td><td>127,0</td><td>150,0</td><td>-</td><td>-</td><td>-</td><td>-</td><td>-</td><td>147,0</td><td>-</td></tr> <tr><td>100</td><td>14,4</td><td>88,0</td><td>121,0</td><td>150,0</td><td>-</td><td>-</td><td>-</td><td>-</td><td>-</td><td>145,5</td><td>-</td></tr> <tr><td>102</td><td>-</td><td>-</td><td>117,0</td><td>150,0</td><td>-</td><td>-</td><td>-</td><td>-</td><td>-</td><td>144,0</td><td>-</td></tr> <tr><td>106</td><td>-</td><td>-</td><td>108,0</td><td>137,0</td><td>-</td><td>-</td><td>-</td><td>-</td><td>-</td><td>137,0</td><td>-</td></tr> <tr><td>110</td><td>-</td><td>-</td><td>100,0</td><td>126,0</td><td>-</td><td>-</td><td>-</td><td>-</td><td>-</td><td>127,0</td><td>-</td></tr> <tr><td>112</td><td>-</td><td>-</td><td>96,0</td><td>121,0</td><td>-</td><td>-</td><td>-</td><td>-</td><td>-</td><td>122,5</td><td>-</td></tr> <tr><td>114</td><td>-</td><td>-</td><td>-</td><td>117,0</td><td>-</td><td>-</td><td>-</td><td>-</td><td>-</td><td>118,0</td><td>-</td></tr> <tr><td>118</td><td>-</td><td>-</td><td>-</td><td>108,0</td><td>-</td><td>-</td><td>-</td><td>-</td><td>-</td><td>110,0</td><td>-</td></tr> <tr><td>120</td><td>-</td><td>-</td><td>-</td><td>104,0</td><td>106,0</td><td>-</td><td>-</td><td>-</td><td>-</td><td>105,0</td><td>-</td></tr> <tr><td>122</td><td>-</td><td>-</td><td>-</td><td>100,0</td><td>103,0</td><td>-</td><td>-</td><td>-</td><td>-</td><td>100,0</td><td>-</td></tr> <tr><td>124</td><td>-</td><td>-</td><td>-</td><td>96,0</td><td>100,0</td><td>-</td><td>-</td><td>-</td><td>-</td><td>94,7</td><td>-</td></tr> <tr><td>126</td><td>-</td><td>-</td><td>-</td><td>-</td><td>97,5</td><td>-</td><td>-</td><td>-</td><td>-</td><td>89,5</td><td>-</td></tr> <tr><td>130</td><td>-</td><td>-</td><td>-</td><td>-</td><td>92,5</td><td>-</td><td>-</td><td>-</td><td>-</td><td>80,0</td><td>-</td></tr> <tr><td>134</td><td>-</td><td>-</td><td>-</td><td>-</td><td>87,5</td><td>-</td><td>-</td><td>-</td><td>-</td><td>70,5</td><td>-</td></tr> <tr><td>136</td><td>-</td><td>-</td><td>-</td><td>-</td><td>85,5</td><td>-</td><td>-</td><td>-</td><td>-</td><td>66,0</td><td>-</td></tr> <tr><td>138</td><td>-</td><td>-</td><td>-</td><td>-</td><td>-</td><td>-</td><td>-</td><td>-</td><td>-</td><td>61,5</td><td>-</td></tr> <tr><td>140</td><td>-</td><td>-</td><td>-</td><td>-</td><td>-</td><td>-</td><td>-</td><td>-</td><td>59,5</td><td>57,0</td><td>-</td></tr> <tr><td>142</td><td>-</td><td>-</td><td>-</td><td>-</td><td>-</td><td>-</td><td>-</td><td>-</td><td>58,0</td><td>52,5</td><td>-</td></tr> <tr><td>146</td><td>-</td><td>-</td><td>-</td><td>-</td><td>-</td><td>-</td><td>-</td><td>-</td><td>54,5</td><td>47,9</td><td>-</td></tr> <tr><td>150</td><td>-</td><td>-</td><td>-</td><td>-</td><td>-</td><td>-</td><td>-</td><td>-</td><td>-</td><td>42,3</td><td>-</td></tr> <tr><td>154</td><td>-</td><td>-</td><td>-</td><td>-</td><td>-</td><td>-</td><td>-</td><td>-</td><td>-</td><td>33,9</td><td>-</td></tr> </tbody> </table>												SWSL										SFSL		0 t		0 t - 640 t											85°	85°	75°	65°	55°	45°						m	t	t	t	t	t	t	t	t	t	t	t	36	-	167,0*	-	-	-	-	-	-	-	-	-	38	-	167,0*	-	-	-	-	-	-	-	-	-	42	-	164,0*	-	-	-	-	-	-	-	-	-	46	86,0	173,0	-	-	-	-	-	-	-	170,0	-	50	76,0	170,0	-	-	-	-	-	-	-	170,0	-	54	67,5	168,0	-	-	-	-	-	-	-	170,0	-	58	60,0	166,0	-	-	-	-	-	-	-	170,0	-	62	53,5	163,0	-	-	-	-	-	-	-	170,0	-	66	47,6	161,0	-	-	-	-	-	-	-	170,0	-	70	42,2	158,0	-	-	-	-	-	-	-	167,0	-	72	39,8	157,0	168,0	-	-	-	-	-	-	166,0	-	74	37,4	156,0	168,0	-	-	-	-	-	-	165,0	-	78	33,0	148,0	168,0	-	-	-	-	-	-	162,0	-	82	29,0	136,0	168,0	-	-	-	-	-	-	159,0	-	86	25,3	125,0	164,0	-	-	-	-	-	-	157,0	-	88	23,6	120,0	157,0	-	-	-	-	-	-	155,0	-	90	22,0	115,5	150,0	-	-	-	-	-	-	153,0	-	94	18,8	105,5	138,0	-	-	-	-	-	-	150,0	-	98	15,8	94,0	127,0	150,0	-	-	-	-	-	147,0	-	100	14,4	88,0	121,0	150,0	-	-	-	-	-	145,5	-	102	-	-	117,0	150,0	-	-	-	-	-	144,0	-	106	-	-	108,0	137,0	-	-	-	-	-	137,0	-	110	-	-	100,0	126,0	-	-	-	-	-	127,0	-	112	-	-	96,0	121,0	-	-	-	-	-	122,5	-	114	-	-	-	117,0	-	-	-	-	-	118,0	-	118	-	-	-	108,0	-	-	-	-	-	110,0	-	120	-	-	-	104,0	106,0	-	-	-	-	105,0	-	122	-	-	-	100,0	103,0	-	-	-	-	100,0	-	124	-	-	-	96,0	100,0	-	-	-	-	94,7	-	126	-	-	-	-	97,5	-	-	-	-	89,5	-	130	-	-	-	-	92,5	-	-	-	-	80,0	-	134	-	-	-	-	87,5	-	-	-	-	70,5	-	136	-	-	-	-	85,5	-	-	-	-	66,0	-	138	-	-	-	-	-	-	-	-	-	61,5	-	140	-	-	-	-	-	-	-	-	59,5	57,0	-	142	-	-	-	-	-	-	-	-	58,0	52,5	-	146	-	-	-	-	-	-	-	-	54,5	47,9	-	150	-	-	-	-	-	-	-	-	-	42,3	-	154	-	-	-	-	-	-	-	-	-	33,9	-												
SWSL										SFSL																																																																																																																																																																																																																																																																																																																																																																																																																																																																																																																																																	
0 t		0 t - 640 t																																																																																																																																																																																																																																																																																																																																																																																																																																																																																																																																																									
	85°	85°	75°	65°	55°	45°																																																																																																																																																																																																																																																																																																																																																																																																																																																																																																																																																					
m	t	t	t	t	t	t	t	t	t	t	t																																																																																																																																																																																																																																																																																																																																																																																																																																																																																																																																																
36	-	167,0*	-	-	-	-	-	-	-	-	-																																																																																																																																																																																																																																																																																																																																																																																																																																																																																																																																																
38	-	167,0*	-	-	-	-	-	-	-	-	-																																																																																																																																																																																																																																																																																																																																																																																																																																																																																																																																																
42	-	164,0*	-	-	-	-	-	-	-	-	-																																																																																																																																																																																																																																																																																																																																																																																																																																																																																																																																																
46	86,0	173,0	-	-	-	-	-	-	-	170,0	-																																																																																																																																																																																																																																																																																																																																																																																																																																																																																																																																																
50	76,0	170,0	-	-	-	-	-	-	-	170,0	-																																																																																																																																																																																																																																																																																																																																																																																																																																																																																																																																																
54	67,5	168,0	-	-	-	-	-	-	-	170,0	-																																																																																																																																																																																																																																																																																																																																																																																																																																																																																																																																																
58	60,0	166,0	-	-	-	-	-	-	-	170,0	-																																																																																																																																																																																																																																																																																																																																																																																																																																																																																																																																																
62	53,5	163,0	-	-	-	-	-	-	-	170,0	-																																																																																																																																																																																																																																																																																																																																																																																																																																																																																																																																																
66	47,6	161,0	-	-	-	-	-	-	-	170,0	-																																																																																																																																																																																																																																																																																																																																																																																																																																																																																																																																																
70	42,2	158,0	-	-	-	-	-	-	-	167,0	-																																																																																																																																																																																																																																																																																																																																																																																																																																																																																																																																																
72	39,8	157,0	168,0	-	-	-	-	-	-	166,0	-																																																																																																																																																																																																																																																																																																																																																																																																																																																																																																																																																
74	37,4	156,0	168,0	-	-	-	-	-	-	165,0	-																																																																																																																																																																																																																																																																																																																																																																																																																																																																																																																																																
78	33,0	148,0	168,0	-	-	-	-	-	-	162,0	-																																																																																																																																																																																																																																																																																																																																																																																																																																																																																																																																																
82	29,0	136,0	168,0	-	-	-	-	-	-	159,0	-																																																																																																																																																																																																																																																																																																																																																																																																																																																																																																																																																
86	25,3	125,0	164,0	-	-	-	-	-	-	157,0	-																																																																																																																																																																																																																																																																																																																																																																																																																																																																																																																																																
88	23,6	120,0	157,0	-	-	-	-	-	-	155,0	-																																																																																																																																																																																																																																																																																																																																																																																																																																																																																																																																																
90	22,0	115,5	150,0	-	-	-	-	-	-	153,0	-																																																																																																																																																																																																																																																																																																																																																																																																																																																																																																																																																
94	18,8	105,5	138,0	-	-	-	-	-	-	150,0	-																																																																																																																																																																																																																																																																																																																																																																																																																																																																																																																																																
98	15,8	94,0	127,0	150,0	-	-	-	-	-	147,0	-																																																																																																																																																																																																																																																																																																																																																																																																																																																																																																																																																
100	14,4	88,0	121,0	150,0	-	-	-	-	-	145,5	-																																																																																																																																																																																																																																																																																																																																																																																																																																																																																																																																																
102	-	-	117,0	150,0	-	-	-	-	-	144,0	-																																																																																																																																																																																																																																																																																																																																																																																																																																																																																																																																																
106	-	-	108,0	137,0	-	-	-	-	-	137,0	-																																																																																																																																																																																																																																																																																																																																																																																																																																																																																																																																																
110	-	-	100,0	126,0	-	-	-	-	-	127,0	-																																																																																																																																																																																																																																																																																																																																																																																																																																																																																																																																																
112	-	-	96,0	121,0	-	-	-	-	-	122,5	-																																																																																																																																																																																																																																																																																																																																																																																																																																																																																																																																																
114	-	-	-	117,0	-	-	-	-	-	118,0	-																																																																																																																																																																																																																																																																																																																																																																																																																																																																																																																																																
118	-	-	-	108,0	-	-	-	-	-	110,0	-																																																																																																																																																																																																																																																																																																																																																																																																																																																																																																																																																
120	-	-	-	104,0	106,0	-	-	-	-	105,0	-																																																																																																																																																																																																																																																																																																																																																																																																																																																																																																																																																
122	-	-	-	100,0	103,0	-	-	-	-	100,0	-																																																																																																																																																																																																																																																																																																																																																																																																																																																																																																																																																
124	-	-	-	96,0	100,0	-	-	-	-	94,7	-																																																																																																																																																																																																																																																																																																																																																																																																																																																																																																																																																
126	-	-	-	-	97,5	-	-	-	-	89,5	-																																																																																																																																																																																																																																																																																																																																																																																																																																																																																																																																																
130	-	-	-	-	92,5	-	-	-	-	80,0	-																																																																																																																																																																																																																																																																																																																																																																																																																																																																																																																																																
134	-	-	-	-	87,5	-	-	-	-	70,5	-																																																																																																																																																																																																																																																																																																																																																																																																																																																																																																																																																
136	-	-	-	-	85,5	-	-	-	-	66,0	-																																																																																																																																																																																																																																																																																																																																																																																																																																																																																																																																																
138	-	-	-	-	-	-	-	-	-	61,5	-																																																																																																																																																																																																																																																																																																																																																																																																																																																																																																																																																
140	-	-	-	-	-	-	-	-	59,5	57,0	-																																																																																																																																																																																																																																																																																																																																																																																																																																																																																																																																																
142	-	-	-	-	-	-	-	-	58,0	52,5	-																																																																																																																																																																																																																																																																																																																																																																																																																																																																																																																																																
146	-	-	-	-	-	-	-	-	54,5	47,9	-																																																																																																																																																																																																																																																																																																																																																																																																																																																																																																																																																
150	-	-	-	-	-	-	-	-	-	42,3	-																																																																																																																																																																																																																																																																																																																																																																																																																																																																																																																																																
154	-	-	-	-	-	-	-	-	-	33,9	-																																																																																																																																																																																																																																																																																																																																																																																																																																																																																																																																																
<table border="1"> <thead> <tr> <th colspan="10">SWSL</th> <th colspan="2">SFSL</th> </tr> <tr> <th colspan="2">0 t</th> <th colspan="8">0 t - 640 t</th> <th colspan="2"></th> </tr> <tr> <th></th> <th>85°</th> <th>85°</th> <th>75°</th> <th>65°</th> <th>55°</th> <th>45°</th> <th></th> <th></th> <th></th> <th></th> <th></th> </tr> <tr> <th>m</th> <th>t</th> <th>t</th> <th>t</th> <th>t</th> <th>t</th> <th>t</th> <th>t</th> <th>t</th> <th>t</th> <th>t</th> <th>t</th> </tr> </thead> <tbody> <tr><td>40</td><td>-</td><td>133,0*</td><td>-</td><td>-</td><td>-</td><td>-</td><td>-</td><td>-</td><td>-</td><td>-</td><td>-</td></tr> <tr><td>42</td><td>-</td><td>132,0*</td><td>-</td><td>-</td><td>-</td><td>-</td><td>-</td><td>-</td><td>-</td><td>-</td><td>-</td></tr> <tr><td>46</td><td>-</td><td>130,0*</td><td>-</td><td>-</td><td>-</td><td>-</td><td>-</td><td>-</td><td>-</td><td>-</td><td>-</td></tr> <tr><td>50</td><td>68,5</td><td>134,0</td><td>-</td><td>-</td><td>-</td><td>-</td><td>-</td><td>-</td><td>-</td><td>133,0</td><td>-</td></tr> <tr><td>54</td><td>60,5</td><td>132,0</td><td>-</td><td>-</td><td>-</td><td>-</td><td>-</td><td>-</td><td>-</td><td>133,0</td><td>-</td></tr> <tr><td>58</td><td>53,0</td><td>131,0</td><td>-</td><td>-</td><td>-</td><td>-</td><td>-</td><td>-</td><td>-</td><td>133,0</td><td>-</td></tr> <tr><td>62</td><td>46,8</td><td>129,0</td><td>-</td><td>-</td><td>-</td><td>-</td><td>-</td><td>-</td><td>-</td><td>132,0</td><td>-</td></tr> <tr><td>66</td><td>41,0</td><td>127,0</td><td>-</td><td>-</td><td>-</td><td>-</td><td>-</td><td>-</td><td>-</td><td>131,0</td><td>-</td></tr> <tr><td>70</td><td>35,8</td><td>125,0</td><td>-</td><td>-</td><td>-</td><td>-</td><td>-</td><td>-</td><td>-</td><td>129,0</td><td>-</td></tr> <tr><td>74</td><td>31,1</td><td>123,0</td><td>-</td><td>-</td><td>-</td><td>-</td><td>-</td><td>-</td><td>-</td><td>128,0</td><td>-</td></tr> <tr><td>78</td><td>26,8</td><td>121,0</td><td>124,0</td><td>-</td><td>-</td><td>-</td><td>-</td><td>-</td><td>-</td><td>125,0</td><td>-</td></tr> <tr><td>80</td><td>24,8</td><td>120,0</td><td>124,0</td><td>-</td><td>-</td><td>-</td><td>-</td><td>-</td><td>-</td><td>124,0</td><td>-</td></tr> <tr><td>82</td><td>22,9</td><td>119,0</td><td>124,0</td><td>-</td><td>-</td><td>-</td><td>-</td><td>-</td><td>-</td><td>123,0</td><td>-</td></tr> <tr><td>86</td><td>19,4</td><td>116,5</td><td>124,0</td><td>-</td><td>-</td><td>-</td><td>-</td><td>-</td><td>-</td><td>121,0</td><td>-</td></tr> <tr><td>90</td><td>16,1</td><td>110,5</td><td>124,0</td><td>-</td><td>-</td><td>-</td><td>-</td><td>-</td><td>-</td><td>119,0</td><td>-</td></tr> <tr><td>94</td><td>13,0</td><td>102,0</td><td>124,0</td><td>-</td><td>-</td><td>-</td><td>-</td><td>-</td><td>-</td><td>117,0</td><td>-</td></tr> <tr><td>96</td><td>11,6</td><td>98,0</td><td>124,0</td><td>-</td><td>-</td><td>-</td><td>-</td><td>-</td><td>-</td><td>116,0</td><td>-</td></tr> <tr><td>98</td><td>-</td><td>94,2</td><td>122,0</td><td>-</td><td>-</td><td>-</td><td>-</td><td>-</td><td>-</td><td>115,0</td><td>-</td></tr> <tr><td>102</td><td>-</td><td>87,0</td><td>112,0</td><td>-</td><td>-</td><td>-</td><td>-</td><td>-</td><td>-</td><td>113,0</td><td>-</td></tr> <tr><td>106</td><td>-</td><td>79,0</td><td>103,0</td><td>109,0</td><td>-</td><td>-</td><td>-</td><td>-</td><td>-</td><td>110,0</td><td>-</td></tr> <tr><td>110</td><td>-</td><td>69,5</td><td>95,0</td><td>109,0</td><td>-</td><td>-</td><td>-</td><td>-</td><td>-</td><td>108,0</td><td>-</td></tr> <tr><td>112</td><td>-</td><td>64,5</td><td>91,5</td><td>109,0</td><td>-</td><td>-</td><td>-</td><td>-</td><td>-</td><td>107,0</td><td>-</td></tr> <tr><td>114</td><td>-</td><td>-</td><td>88,0</td><td>109,0</td><td>-</td><td>-</td><td>-</td><td>-</td><td>-</td><td>106,0</td><td>-</td></tr> <tr><td>118</td><td>-</td><td>-</td><td>81,0</td><td>103,0</td><td>-</td><td>-</td><td>-</td><td>-</td><td>-</td><td>104,0</td><td>-</td></tr> <tr><td>122</td><td>-</td><td>-</td><td>75,0</td><td>95,0</td><td>-</td><td>-</td><td>-</td><td>-</td><td>-</td><td>101,0</td><td>-</td></tr> <tr><td>124</td><td>-</td><td>-</td><td>72,0</td><td>91,5</td><td>-</td><td>-</td><td>-</td><td>-</td><td>-</td><td>97,0</td><td>-</td></tr> <tr><td>126</td><td>-</td><td>-</td><td>-</td><td>88,0</td><td>-</td><td>-</td><td>-</td><td>-</td><td>-</td><td>93,0</td><td>-</td></tr> <tr><td>130</td><td>-</td><td>-</td><td>-</td><td>81,0</td><td>85,5</td><td>-</td><td>-</td><td>-</td><td>-</td><td>83,5</td><td>-</td></tr> <tr><td>134</td><td>-</td><td>-</td><td>-</td><td>75,0</td><td>80,5</td><td>-</td><td>-</td><td>-</td><td>-</td><td>75,0</td><td>-</td></tr> <tr><td>136</td><td>-</td><td>-</td><td>-</td><td>72,5</td><td>78,5</td><td>-</td><td>-</td><td>-</td><td>-</td><td>70,5</td><td>-</td></tr> <tr><td>138</td><td>-</td><td>-</td><td>-</td><td>-</td><td>76,0</td><td>-</td><td>-</td><td>-</td><td>-</td><td>66,0</td><td>-</td></tr> <tr><td>142</td><td>-</td><td>-</td><td>-</td><td>-</td><td>72,0</td><td>-</td><td>-</td><td>-</td><td>-</td><td>58,0</td><td>-</td></tr> <tr><td>146</td><td>-</td><td>-</td><td>-</td><td>-</td><td>68,5</td><td>-</td><td>-</td><td>-</td><td>-</td><td>50,0</td><td>-</td></tr> <tr><td>148</td><td>-</td><td>-</td><td>-</td><td>-</td><td>66,5</td><td>-</td><td>-</td><td>-</td><td>-</td><td>46,2</td><td>-</td></tr> <tr><td>150</td><td>-</td><td>-</td><td>-</td><td>-</td><td>-</td><td>-</td><td>-</td><td>-</td><td>44,4</td><td>43,0</td><td>-</td></tr> <tr><td>154</td><td>-</td><td>-</td><td>-</td><td>-</td><td>-</td><td>-</td><td>-</td><td>-</td><td>41,7</td><td>39,4</td><td>-</td></tr> <tr><td>156</td><td>-</td><td>-</td><td>-</td><td>-</td><td>-</td><td>-</td><td>-</td><td>-</td><td>40,8</td><td>36,4</td><td>-</td></tr> <tr><td>158</td><td>-</td><td>-</td><td>-</td><td>-</td><td>-</td><td>-</td><td>-</td><td>-</td><td>-</td><td>33,5</td><td>-</td></tr> <tr><td>162</td><td>-</td><td>-</td><td>-</td><td>-</td><td>-</td><td>-</td><td>-</td><td>-</td><td>-</td><td>26,2</td><td>-</td></tr> <tr><td>166</td><td>-</td><td>-</td><td>-</td><td>-</td><td>-</td><td>-</td><td>-</td><td>-</td><td>-</td><td>18,9</td><td>-</td></tr> </tbody> </table>												SWSL										SFSL		0 t		0 t - 640 t											85°	85°	75°	65°	55°	45°						m	t	t	t	t	t	t	t	t	t	t	t	40	-	133,0*	-	-	-	-	-	-	-	-	-	42	-	132,0*	-	-	-	-	-	-	-	-	-	46	-	130,0*	-	-	-	-	-	-	-	-	-	50	68,5	134,0	-	-	-	-	-	-	-	133,0	-	54	60,5	132,0	-	-	-	-	-	-	-	133,0	-	58	53,0	131,0	-	-	-	-	-	-	-	133,0	-	62	46,8	129,0	-	-	-	-	-	-	-	132,0	-	66	41,0	127,0	-	-	-	-	-	-	-	131,0	-	70	35,8	125,0	-	-	-	-	-	-	-	129,0	-	74	31,1	123,0	-	-	-	-	-	-	-	128,0	-	78	26,8	121,0	124,0	-	-	-	-	-	-	125,0	-	80	24,8	120,0	124,0	-	-	-	-	-	-	124,0	-	82	22,9	119,0	124,0	-	-	-	-	-	-	123,0	-	86	19,4	116,5	124,0	-	-	-	-	-	-	121,0	-	90	16,1	110,5	124,0	-	-	-	-	-	-	119,0	-	94	13,0	102,0	124,0	-	-	-	-	-	-	117,0	-	96	11,6	98,0	124,0	-	-	-	-	-	-	116,0	-	98	-	94,2	122,0	-	-	-	-	-	-	115,0	-	102	-	87,0	112,0	-	-	-	-	-	-	113,0	-	106	-	79,0	103,0	109,0	-	-	-	-	-	110,0	-	110	-	69,5	95,0	109,0	-	-	-	-	-	108,0	-	112	-	64,5	91,5	109,0	-	-	-	-	-	107,0	-	114	-	-	88,0	109,0	-	-	-	-	-	106,0	-	118	-	-	81,0	103,0	-	-	-	-	-	104,0	-	122	-	-	75,0	95,0	-	-	-	-	-	101,0	-	124	-	-	72,0	91,5	-	-	-	-	-	97,0	-	126	-	-	-	88,0	-	-	-	-	-	93,0	-	130	-	-	-	81,0	85,5	-	-	-	-	83,5	-	134	-	-	-	75,0	80,5	-	-	-	-	75,0	-	136	-	-	-	72,5	78,5	-	-	-	-	70,5	-	138	-	-	-	-	76,0	-	-	-	-	66,0	-	142	-	-	-	-	72,0	-	-	-	-	58,0	-	146	-	-	-	-	68,5	-	-	-	-	50,0	-	148	-	-	-	-	66,5	-	-	-	-	46,2	-	150	-	-	-	-	-	-	-	-	44,4	43,0	-	154	-	-	-	-	-	-	-	-	41,7	39,4	-	156	-	-	-	-	-	-	-	-	40,8	36,4	-	158	-	-	-	-	-	-	-	-	-	33,5	-	162	-	-	-	-	-	-	-	-	-	26,2	-	166	-	-	-	-	-	-	-	-	-	18,9	-
SWSL										SFSL																																																																																																																																																																																																																																																																																																																																																																																																																																																																																																																																																	
0 t		0 t - 640 t																																																																																																																																																																																																																																																																																																																																																																																																																																																																																																																																																									
	85°	85°	75°	65°	55°	45°																																																																																																																																																																																																																																																																																																																																																																																																																																																																																																																																																					
m	t	t	t	t	t	t	t	t	t	t	t																																																																																																																																																																																																																																																																																																																																																																																																																																																																																																																																																
40	-	133,0*	-	-	-	-	-	-	-	-	-																																																																																																																																																																																																																																																																																																																																																																																																																																																																																																																																																
42	-	132,0*	-	-	-	-	-	-	-	-	-																																																																																																																																																																																																																																																																																																																																																																																																																																																																																																																																																
46	-	130,0*	-	-	-	-	-	-	-	-	-																																																																																																																																																																																																																																																																																																																																																																																																																																																																																																																																																
50	68,5	134,0	-	-	-	-	-	-	-	133,0	-																																																																																																																																																																																																																																																																																																																																																																																																																																																																																																																																																
54	60,5	132,0	-	-	-	-	-	-	-	133,0	-																																																																																																																																																																																																																																																																																																																																																																																																																																																																																																																																																
58	53,0	131,0	-	-	-	-	-	-	-	133,0	-																																																																																																																																																																																																																																																																																																																																																																																																																																																																																																																																																
62	46,8	129,0	-	-	-	-	-	-	-	132,0	-																																																																																																																																																																																																																																																																																																																																																																																																																																																																																																																																																
66	41,0	127,0	-	-	-	-	-	-	-	131,0	-																																																																																																																																																																																																																																																																																																																																																																																																																																																																																																																																																
70	35,8	125,0	-	-	-	-	-	-	-	129,0	-																																																																																																																																																																																																																																																																																																																																																																																																																																																																																																																																																
74	31,1	123,0	-	-	-	-	-	-	-	128,0	-																																																																																																																																																																																																																																																																																																																																																																																																																																																																																																																																																
78	26,8	121,0	124,0	-	-	-	-	-	-	125,0	-																																																																																																																																																																																																																																																																																																																																																																																																																																																																																																																																																
80	24,8	120,0	124,0	-	-	-	-	-	-	124,0	-																																																																																																																																																																																																																																																																																																																																																																																																																																																																																																																																																
82	22,9	119,0	124,0	-	-	-	-	-	-	123,0	-																																																																																																																																																																																																																																																																																																																																																																																																																																																																																																																																																
86	19,4	116,5	124,0	-	-	-	-	-	-	121,0	-																																																																																																																																																																																																																																																																																																																																																																																																																																																																																																																																																
90	16,1	110,5	124,0	-	-	-	-	-	-	119,0	-																																																																																																																																																																																																																																																																																																																																																																																																																																																																																																																																																
94	13,0	102,0	124,0	-	-	-	-	-	-	117,0	-																																																																																																																																																																																																																																																																																																																																																																																																																																																																																																																																																
96	11,6	98,0	124,0	-	-	-	-	-	-	116,0	-																																																																																																																																																																																																																																																																																																																																																																																																																																																																																																																																																
98	-	94,2	122,0	-	-	-	-	-	-	115,0	-																																																																																																																																																																																																																																																																																																																																																																																																																																																																																																																																																
102	-	87,0	112,0	-	-	-	-	-	-	113,0	-																																																																																																																																																																																																																																																																																																																																																																																																																																																																																																																																																
106	-	79,0	103,0	109,0	-	-	-	-	-	110,0	-																																																																																																																																																																																																																																																																																																																																																																																																																																																																																																																																																
110	-	69,5	95,0	109,0	-	-	-	-	-	108,0	-																																																																																																																																																																																																																																																																																																																																																																																																																																																																																																																																																
112	-	64,5	91,5	109,0	-	-	-	-	-	107,0	-																																																																																																																																																																																																																																																																																																																																																																																																																																																																																																																																																
114	-	-	88,0	109,0	-	-	-	-	-	106,0	-																																																																																																																																																																																																																																																																																																																																																																																																																																																																																																																																																
118	-	-	81,0	103,0	-	-	-	-	-	104,0	-																																																																																																																																																																																																																																																																																																																																																																																																																																																																																																																																																
122	-	-	75,0	95,0	-	-	-	-	-	101,0	-																																																																																																																																																																																																																																																																																																																																																																																																																																																																																																																																																
124	-	-	72,0	91,5	-	-	-	-	-	97,0	-																																																																																																																																																																																																																																																																																																																																																																																																																																																																																																																																																
126	-	-	-	88,0	-	-	-	-	-	93,0	-																																																																																																																																																																																																																																																																																																																																																																																																																																																																																																																																																
130	-	-	-	81,0	85,5	-	-	-	-	83,5	-																																																																																																																																																																																																																																																																																																																																																																																																																																																																																																																																																
134	-	-	-	75,0	80,5	-	-	-	-	75,0	-																																																																																																																																																																																																																																																																																																																																																																																																																																																																																																																																																
136	-	-	-	72,5	78,5	-	-	-	-	70,5	-																																																																																																																																																																																																																																																																																																																																																																																																																																																																																																																																																
138	-	-	-	-	76,0	-	-	-	-	66,0	-																																																																																																																																																																																																																																																																																																																																																																																																																																																																																																																																																
142	-	-	-	-	72,0	-	-	-	-	58,0	-																																																																																																																																																																																																																																																																																																																																																																																																																																																																																																																																																
146	-	-	-	-	68,5	-	-	-	-	50,0	-																																																																																																																																																																																																																																																																																																																																																																																																																																																																																																																																																
148	-	-	-	-	66,5	-	-	-	-	46,2	-																																																																																																																																																																																																																																																																																																																																																																																																																																																																																																																																																
150	-	-	-	-	-	-	-	-	44,4	43,0	-																																																																																																																																																																																																																																																																																																																																																																																																																																																																																																																																																
154	-	-	-	-	-	-	-	-	41,7	39,4	-																																																																																																																																																																																																																																																																																																																																																																																																																																																																																																																																																
156	-	-	-	-	-	-	-	-	40,8	36,4	-																																																																																																																																																																																																																																																																																																																																																																																																																																																																																																																																																
158	-	-	-	-	-	-	-	-	-	33,5	-																																																																																																																																																																																																																																																																																																																																																																																																																																																																																																																																																
162	-	-	-	-	-	-	-	-	-	26,2	-																																																																																																																																																																																																																																																																																																																																																																																																																																																																																																																																																
166	-	-	-	-	-	-	-	-	-	18,9	-																																																																																																																																																																																																																																																																																																																																																																																																																																																																																																																																																

6 m steps of luffing jib is standard · 6 m Stufung der Wippe ist Standard · Des paliers de 6 m sont de série pour la fléchette

Main boom angle 88°, 85°, 75°, 65°, 55° and 45°; capacities for intermediate boom positions are calculated by the crane control system IC-1  
 Hauptauslegerwinkel 88°, 85°, 75°, 65°, 55° und 45°; Traglasten für Zwischenstellungen des Hauptauslegers werden von der Kransteuerung IC-1 berechnet

Jarret de flèche principale 88°, 85°, 75°, 65°, 55° et 45° ; le système de commande de la grue IC-1 calcule les charges pour les positions intermédiaires de la flèche

\* Main boom angle 88° · Hauptauslegerwinkel 88° · Jarret de flèche principale 88°

295 t + 60 t ZB		19-30 m		10,5 m		9.8 m/s		360°		ISO																																																																																																																																																																																																																																																																																																																																																																																																																																					
78 m + 36 m						78 m + 48 m																																																																																																																																																																																																																																																																																																																																																																																																																																									
<table border="1"> <thead> <tr> <th colspan="11">SWSL</th> <th>SFSL</th> </tr> <tr> <th colspan="11">0 t</th> <th>0 t - 640 t</th> </tr> <tr> <th colspan="11">85° 85° 75° 65° 55° 45°</th> <th></th> </tr> <tr> <th>m</th> <th>t</th> <th>t</th> <th>t</th> <th>t</th> <th>t</th> <th>t</th> <th>t</th> <th>t</th> <th>t</th> <th>t</th> <th>t</th> </tr> </thead> <tbody> <tr><td>20</td><td>-</td><td>449,0*</td><td>-</td><td>-</td><td>-</td><td>-</td><td>-</td><td>-</td><td>-</td><td>-</td><td>-</td></tr> <tr><td>22</td><td>-</td><td>436,0*</td><td>-</td><td>-</td><td>-</td><td>-</td><td>-</td><td>-</td><td>-</td><td>-</td><td>-</td></tr> <tr><td>24</td><td>-</td><td>422,0*</td><td>-</td><td>-</td><td>-</td><td>-</td><td>-</td><td>-</td><td>-</td><td>-</td><td>-</td></tr> <tr><td>26</td><td>230,0</td><td>469,0</td><td>-</td><td>-</td><td>-</td><td>-</td><td>-</td><td>-</td><td>-</td><td>460,0</td><td>-</td></tr> <tr><td>28</td><td>214,0</td><td>459,0</td><td>-</td><td>-</td><td>-</td><td>-</td><td>-</td><td>-</td><td>-</td><td>460,0</td><td>-</td></tr> <tr><td>30</td><td>200,0</td><td>449,0</td><td>-</td><td>-</td><td>-</td><td>-</td><td>-</td><td>-</td><td>-</td><td>460,0</td><td>-</td></tr> <tr><td>34</td><td>175,0</td><td>429,0</td><td>-</td><td>-</td><td>-</td><td>-</td><td>-</td><td>-</td><td>-</td><td>460,0</td><td>-</td></tr> <tr><td>38</td><td>156,0</td><td>410,0</td><td>-</td><td>-</td><td>-</td><td>-</td><td>-</td><td>-</td><td>-</td><td>460,0</td><td>-</td></tr> <tr><td>42</td><td>138,0</td><td>353,0</td><td>-</td><td>-</td><td>-</td><td>-</td><td>-</td><td>-</td><td>-</td><td>451,0</td><td>-</td></tr> <tr><td>44</td><td>129,0</td><td>329,0</td><td>463,0</td><td>-</td><td>-</td><td>-</td><td>-</td><td>-</td><td>-</td><td>439,0</td><td>-</td></tr> <tr><td>46</td><td>-</td><td>-</td><td>463,0</td><td>-</td><td>-</td><td>-</td><td>-</td><td>-</td><td>-</td><td>427,0</td><td>-</td></tr> <tr><td>50</td><td>-</td><td>-</td><td>427,0</td><td>-</td><td>-</td><td>-</td><td>-</td><td>-</td><td>-</td><td>408,0</td><td>-</td></tr> <tr><td>54</td><td>-</td><td>-</td><td>373,0</td><td>-</td><td>-</td><td>-</td><td>-</td><td>-</td><td>-</td><td>372,0</td><td>-</td></tr> <tr><td>58</td><td>-</td><td>-</td><td>323,0</td><td>-</td><td>-</td><td>-</td><td>-</td><td>-</td><td>-</td><td>337,0</td><td>-</td></tr> <tr><td>61</td><td>-</td><td>-</td><td>-</td><td>316,0</td><td>-</td><td>-</td><td>-</td><td>-</td><td>-</td><td>314,5</td><td>-</td></tr> <tr><td>62</td><td>-</td><td>-</td><td>-</td><td>311,0</td><td>-</td><td>-</td><td>-</td><td>-</td><td>-</td><td>307,0</td><td>-</td></tr> <tr><td>66</td><td>-</td><td>-</td><td>-</td><td>289,0</td><td>-</td><td>-</td><td>-</td><td>-</td><td>-</td><td>280,0</td><td>-</td></tr> <tr><td>70</td><td>-</td><td>-</td><td>-</td><td>270,0</td><td>-</td><td>-</td><td>-</td><td>-</td><td>-</td><td>257,0</td><td>-</td></tr> <tr><td>71</td><td>-</td><td>-</td><td>-</td><td>266,0</td><td>-</td><td>-</td><td>-</td><td>-</td><td>-</td><td>251,7</td><td>-</td></tr> <tr><td>74</td><td>-</td><td>-</td><td>-</td><td>-</td><td>-</td><td>-</td><td>-</td><td>-</td><td>-</td><td>236,0</td><td>-</td></tr> <tr><td>77</td><td>-</td><td>-</td><td>-</td><td>-</td><td>224,0</td><td>-</td><td>-</td><td>-</td><td>-</td><td>222,5</td><td>-</td></tr> <tr><td>78</td><td>-</td><td>-</td><td>-</td><td>-</td><td>220,0</td><td>-</td><td>-</td><td>-</td><td>-</td><td>218,0</td><td>-</td></tr> <tr><td>82</td><td>-</td><td>-</td><td>-</td><td>-</td><td>208,0</td><td>-</td><td>-</td><td>-</td><td>-</td><td>201,0</td><td>-</td></tr> <tr><td>86</td><td>-</td><td>-</td><td>-</td><td>-</td><td>-</td><td>-</td><td>-</td><td>-</td><td>-</td><td>184,0</td><td>-</td></tr> <tr><td>90</td><td>-</td><td>-</td><td>-</td><td>-</td><td>-</td><td>-</td><td>-</td><td>-</td><td>-</td><td>164,0</td><td>-</td></tr> <tr><td>91</td><td>-</td><td>-</td><td>-</td><td>-</td><td>-</td><td>-</td><td>-</td><td>-</td><td>161,0</td><td>159,2</td><td>-</td></tr> <tr><td>93</td><td>-</td><td>-</td><td>-</td><td>-</td><td>-</td><td>-</td><td>-</td><td>-</td><td>156,0</td><td>149,7</td><td>-</td></tr> <tr><td>94</td><td>-</td><td>-</td><td>-</td><td>-</td><td>-</td><td>-</td><td>-</td><td>-</td><td>-</td><td>145,0</td><td>-</td></tr> <tr><td>98</td><td>-</td><td>-</td><td>-</td><td>-</td><td>-</td><td>-</td><td>-</td><td>-</td><td>-</td><td>127,0</td><td>-</td></tr> <tr><td>102</td><td>-</td><td>-</td><td>-</td><td>-</td><td>-</td><td>-</td><td>-</td><td>-</td><td>-</td><td>112,0</td><td>-</td></tr> </tbody> </table>												SWSL											SFSL	0 t											0 t - 640 t	85° 85° 75° 65° 55° 45°												m	t	t	t	t	t	t	t	t	t	t	t	20	-	449,0*	-	-	-	-	-	-	-	-	-	22	-	436,0*	-	-	-	-	-	-	-	-	-	24	-	422,0*	-	-	-	-	-	-	-	-	-	26	230,0	469,0	-	-	-	-	-	-	-	460,0	-	28	214,0	459,0	-	-	-	-	-	-	-	460,0	-	30	200,0	449,0	-	-	-	-	-	-	-	460,0	-	34	175,0	429,0	-	-	-	-	-	-	-	460,0	-	38	156,0	410,0	-	-	-	-	-	-	-	460,0	-	42	138,0	353,0	-	-	-	-	-	-	-	451,0	-	44	129,0	329,0	463,0	-	-	-	-	-	-	439,0	-	46	-	-	463,0	-	-	-	-	-	-	427,0	-	50	-	-	427,0	-	-	-	-	-	-	408,0	-	54	-	-	373,0	-	-	-	-	-	-	372,0	-	58	-	-	323,0	-	-	-	-	-	-	337,0	-	61	-	-	-	316,0	-	-	-	-	-	314,5	-	62	-	-	-	311,0	-	-	-	-	-	307,0	-	66	-	-	-	289,0	-	-	-	-	-	280,0	-	70	-	-	-	270,0	-	-	-	-	-	257,0	-	71	-	-	-	266,0	-	-	-	-	-	251,7	-	74	-	-	-	-	-	-	-	-	-	236,0	-	77	-	-	-	-	224,0	-	-	-	-	222,5	-	78	-	-	-	-	220,0	-	-	-	-	218,0	-	82	-	-	-	-	208,0	-	-	-	-	201,0	-	86	-	-	-	-	-	-	-	-	-	184,0	-	90	-	-	-	-	-	-	-	-	-	164,0	-	91	-	-	-	-	-	-	-	-	161,0	159,2	-	93	-	-	-	-	-	-	-	-	156,0	149,7	-	94	-	-	-	-	-	-	-	-	-	145,0	-	98	-	-	-	-	-	-	-	-	-	127,0	-	102	-	-	-	-	-	-	-	-	-	112,0	-												
SWSL											SFSL																																																																																																																																																																																																																																																																																																																																																																																																																																				
0 t											0 t - 640 t																																																																																																																																																																																																																																																																																																																																																																																																																																				
85° 85° 75° 65° 55° 45°																																																																																																																																																																																																																																																																																																																																																																																																																																															
m	t	t	t	t	t	t	t	t	t	t	t																																																																																																																																																																																																																																																																																																																																																																																																																																				
20	-	449,0*	-	-	-	-	-	-	-	-	-																																																																																																																																																																																																																																																																																																																																																																																																																																				
22	-	436,0*	-	-	-	-	-	-	-	-	-																																																																																																																																																																																																																																																																																																																																																																																																																																				
24	-	422,0*	-	-	-	-	-	-	-	-	-																																																																																																																																																																																																																																																																																																																																																																																																																																				
26	230,0	469,0	-	-	-	-	-	-	-	460,0	-																																																																																																																																																																																																																																																																																																																																																																																																																																				
28	214,0	459,0	-	-	-	-	-	-	-	460,0	-																																																																																																																																																																																																																																																																																																																																																																																																																																				
30	200,0	449,0	-	-	-	-	-	-	-	460,0	-																																																																																																																																																																																																																																																																																																																																																																																																																																				
34	175,0	429,0	-	-	-	-	-	-	-	460,0	-																																																																																																																																																																																																																																																																																																																																																																																																																																				
38	156,0	410,0	-	-	-	-	-	-	-	460,0	-																																																																																																																																																																																																																																																																																																																																																																																																																																				
42	138,0	353,0	-	-	-	-	-	-	-	451,0	-																																																																																																																																																																																																																																																																																																																																																																																																																																				
44	129,0	329,0	463,0	-	-	-	-	-	-	439,0	-																																																																																																																																																																																																																																																																																																																																																																																																																																				
46	-	-	463,0	-	-	-	-	-	-	427,0	-																																																																																																																																																																																																																																																																																																																																																																																																																																				
50	-	-	427,0	-	-	-	-	-	-	408,0	-																																																																																																																																																																																																																																																																																																																																																																																																																																				
54	-	-	373,0	-	-	-	-	-	-	372,0	-																																																																																																																																																																																																																																																																																																																																																																																																																																				
58	-	-	323,0	-	-	-	-	-	-	337,0	-																																																																																																																																																																																																																																																																																																																																																																																																																																				
61	-	-	-	316,0	-	-	-	-	-	314,5	-																																																																																																																																																																																																																																																																																																																																																																																																																																				
62	-	-	-	311,0	-	-	-	-	-	307,0	-																																																																																																																																																																																																																																																																																																																																																																																																																																				
66	-	-	-	289,0	-	-	-	-	-	280,0	-																																																																																																																																																																																																																																																																																																																																																																																																																																				
70	-	-	-	270,0	-	-	-	-	-	257,0	-																																																																																																																																																																																																																																																																																																																																																																																																																																				
71	-	-	-	266,0	-	-	-	-	-	251,7	-																																																																																																																																																																																																																																																																																																																																																																																																																																				
74	-	-	-	-	-	-	-	-	-	236,0	-																																																																																																																																																																																																																																																																																																																																																																																																																																				
77	-	-	-	-	224,0	-	-	-	-	222,5	-																																																																																																																																																																																																																																																																																																																																																																																																																																				
78	-	-	-	-	220,0	-	-	-	-	218,0	-																																																																																																																																																																																																																																																																																																																																																																																																																																				
82	-	-	-	-	208,0	-	-	-	-	201,0	-																																																																																																																																																																																																																																																																																																																																																																																																																																				
86	-	-	-	-	-	-	-	-	-	184,0	-																																																																																																																																																																																																																																																																																																																																																																																																																																				
90	-	-	-	-	-	-	-	-	-	164,0	-																																																																																																																																																																																																																																																																																																																																																																																																																																				
91	-	-	-	-	-	-	-	-	161,0	159,2	-																																																																																																																																																																																																																																																																																																																																																																																																																																				
93	-	-	-	-	-	-	-	-	156,0	149,7	-																																																																																																																																																																																																																																																																																																																																																																																																																																				
94	-	-	-	-	-	-	-	-	-	145,0	-																																																																																																																																																																																																																																																																																																																																																																																																																																				
98	-	-	-	-	-	-	-	-	-	127,0	-																																																																																																																																																																																																																																																																																																																																																																																																																																				
102	-	-	-	-	-	-	-	-	-	112,0	-																																																																																																																																																																																																																																																																																																																																																																																																																																				
<table border="1"> <thead> <tr> <th colspan="11">SWSL</th> <th>SFSL</th> </tr> <tr> <th colspan="11">0 t</th> <th>0 t - 640 t</th> </tr> <tr> <th colspan="11">85° 85° 75° 65° 55° 45°</th> <th></th> </tr> <tr> <th>m</th> <th>t</th> <th>t</th> <th>t</th> <th>t</th> <th>t</th> <th>t</th> <th>t</th> <th>t</th> <th>t</th> <th>t</th> <th>t</th> </tr> </thead> <tbody> <tr><td>22</td><td>-</td><td>362,0*</td><td>-</td><td>-</td><td>-</td><td>-</td><td>-</td><td>-</td><td>-</td><td>-</td><td>-</td></tr> <tr><td>24</td><td>-</td><td>358,0*</td><td>-</td><td>-</td><td>-</td><td>-</td><td>-</td><td>-</td><td>-</td><td>-</td><td>-</td></tr> <tr><td>26</td><td>-</td><td>349,0*</td><td>-</td><td>-</td><td>-</td><td>-</td><td>-</td><td>-</td><td>-</td><td>-</td><td>-</td></tr> <tr><td>28</td><td>-</td><td>340,0</td><td>-</td><td>-</td><td>-</td><td>-</td><td>-</td><td>-</td><td>-</td><td>-</td><td>-</td></tr> <tr><td>30</td><td>186,0</td><td>377,0</td><td>-</td><td>-</td><td>-</td><td>-</td><td>-</td><td>-</td><td>-</td><td>368,0</td><td>-</td></tr> <tr><td>34</td><td>163,0</td><td>364,0</td><td>-</td><td>-</td><td>-</td><td>-</td><td>-</td><td>-</td><td>-</td><td>368,0</td><td>-</td></tr> <tr><td>38</td><td>145,0</td><td>351,0</td><td>-</td><td>-</td><td>-</td><td>-</td><td>-</td><td>-</td><td>-</td><td>368,0</td><td>-</td></tr> <tr><td>42</td><td>129,0</td><td>338,0</td><td>-</td><td>-</td><td>-</td><td>-</td><td>-</td><td>-</td><td>-</td><td>368,0</td><td>-</td></tr> <tr><td>46</td><td>116,0</td><td>326,0</td><td>-</td><td>-</td><td>-</td><td>-</td><td>-</td><td>-</td><td>-</td><td>367,0</td><td>-</td></tr> <tr><td>50</td><td>103,0</td><td>292,0</td><td>386,0</td><td>-</td><td>-</td><td>-</td><td>-</td><td>-</td><td>-</td><td>355,0</td><td>-</td></tr> <tr><td>54</td><td>92,0</td><td>260,0</td><td>379,0</td><td>-</td><td>-</td><td>-</td><td>-</td><td>-</td><td>-</td><td>339,0</td><td>-</td></tr> <tr><td>56</td><td>87,0</td><td>240,0</td><td>370,0</td><td>-</td><td>-</td><td>-</td><td>-</td><td>-</td><td>-</td><td>333,0</td><td>-</td></tr> <tr><td>58</td><td>-</td><td>-</td><td>348,0</td><td>-</td><td>-</td><td>-</td><td>-</td><td>-</td><td>-</td><td>327,0</td><td>-</td></tr> <tr><td>62</td><td>-</td><td>-</td><td>305,0</td><td>-</td><td>-</td><td>-</td><td>-</td><td>-</td><td>-</td><td>310,0</td><td>-</td></tr> <tr><td>66</td><td>-</td><td>-</td><td>271,0</td><td>-</td><td>-</td><td>-</td><td>-</td><td>-</td><td>-</td><td>284,0</td><td>-</td></tr> <tr><td>68</td><td>-</td><td>-</td><td>257,0</td><td>-</td><td>-</td><td>-</td><td>-</td><td>-</td><td>-</td><td>272,0</td><td>-</td></tr> <tr><td>69</td><td>-</td><td>-</td><td>-</td><td>268,0</td><td>-</td><td>-</td><td>-</td><td>-</td><td>-</td><td>266,0</td><td>-</td></tr> <tr><td>70</td><td>-</td><td>-</td><td>-</td><td>264,0</td><td>-</td><td>-</td><td>-</td><td>-</td><td>-</td><td>260,0</td><td>-</td></tr> <tr><td>74</td><td>-</td><td>-</td><td>-</td><td>247,0</td><td>-</td><td>-</td><td>-</td><td>-</td><td>-</td><td>239,0</td><td>-</td></tr> <tr><td>78</td><td>-</td><td>-</td><td>-</td><td>232,0</td><td>-</td><td>-</td><td>-</td><td>-</td><td>-</td><td>220,0</td><td>-</td></tr> <tr><td>82</td><td>-</td><td>-</td><td>-</td><td>219,0</td><td>-</td><td>-</td><td>-</td><td>-</td><td>-</td><td>203,0</td><td>-</td></tr> <tr><td>86</td><td>-</td><td>-</td><td>-</td><td>-</td><td>-</td><td>-</td><td>-</td><td>-</td><td>-</td><td>188,0</td><td>-</td></tr> <tr><td>87</td><td>-</td><td>-</td><td>-</td><td>-</td><td>-</td><td>187,0</td><td>-</td><td>-</td><td>-</td><td>184,5</td><td>-</td></tr> <tr><td>90</td><td>-</td><td>-</td><td>-</td><td>-</td><td>-</td><td>179,0</td><td>-</td><td>-</td><td>-</td><td>174,0</td><td>-</td></tr> <tr><td>94</td><td>-</td><td>-</td><td>-</td><td>-</td><td>-</td><td>170,0</td><td>-</td><td>-</td><td>-</td><td>161,0</td><td>-</td></tr> <tr><td>98</td><td>-</td><td>-</td><td>-</td><td>-</td><td>-</td><td>-</td><td>-</td><td>-</td><td>-</td><td>144,0</td><td>-</td></tr> <tr><td>102</td><td>-</td><td>-</td><td>-</td><td>-</td><td>-</td><td>-</td><td>-</td><td>-</td><td>131,0</td><td>128,0</td><td>-</td></tr> <tr><td>104</td><td>-</td><td>-</td><td>-</td><td>-</td><td>-</td><td>-</td><td>-</td><td>-</td><td>127,0</td><td>120,5</td><td>-</td></tr> <tr><td>106</td><td>-</td><td>-</td><td>-</td><td>-</td><td>-</td><td>-</td><td>-</td><td>-</td><td>-</td><td>113,0</td><td>-</td></tr> <tr><td>110</td><td>-</td><td>-</td><td>-</td><td>-</td><td>-</td><td>-</td><td>-</td><td>-</td><td>-</td><td>98,5</td><td>-</td></tr> <tr><td>114</td><td>-</td><td>-</td><td>-</td><td>-</td><td>-</td><td>-</td><td>-</td><td>-</td><td>-</td><td>89,5</td><td>-</td></tr> </tbody> </table>												SWSL											SFSL	0 t											0 t - 640 t	85° 85° 75° 65° 55° 45°												m	t	t	t	t	t	t	t	t	t	t	t	22	-	362,0*	-	-	-	-	-	-	-	-	-	24	-	358,0*	-	-	-	-	-	-	-	-	-	26	-	349,0*	-	-	-	-	-	-	-	-	-	28	-	340,0	-	-	-	-	-	-	-	-	-	30	186,0	377,0	-	-	-	-	-	-	-	368,0	-	34	163,0	364,0	-	-	-	-	-	-	-	368,0	-	38	145,0	351,0	-	-	-	-	-	-	-	368,0	-	42	129,0	338,0	-	-	-	-	-	-	-	368,0	-	46	116,0	326,0	-	-	-	-	-	-	-	367,0	-	50	103,0	292,0	386,0	-	-	-	-	-	-	355,0	-	54	92,0	260,0	379,0	-	-	-	-	-	-	339,0	-	56	87,0	240,0	370,0	-	-	-	-	-	-	333,0	-	58	-	-	348,0	-	-	-	-	-	-	327,0	-	62	-	-	305,0	-	-	-	-	-	-	310,0	-	66	-	-	271,0	-	-	-	-	-	-	284,0	-	68	-	-	257,0	-	-	-	-	-	-	272,0	-	69	-	-	-	268,0	-	-	-	-	-	266,0	-	70	-	-	-	264,0	-	-	-	-	-	260,0	-	74	-	-	-	247,0	-	-	-	-	-	239,0	-	78	-	-	-	232,0	-	-	-	-	-	220,0	-	82	-	-	-	219,0	-	-	-	-	-	203,0	-	86	-	-	-	-	-	-	-	-	-	188,0	-	87	-	-	-	-	-	187,0	-	-	-	184,5	-	90	-	-	-	-	-	179,0	-	-	-	174,0	-	94	-	-	-	-	-	170,0	-	-	-	161,0	-	98	-	-	-	-	-	-	-	-	-	144,0	-	102	-	-	-	-	-	-	-	-	131,0	128,0	-	104	-	-	-	-	-	-	-	-	127,0	120,5	-	106	-	-	-	-	-	-	-	-	-	113,0	-	110	-	-	-	-	-	-	-	-	-	98,5	-	114	-	-	-	-	-	-	-	-	-	89,5	-
SWSL											SFSL																																																																																																																																																																																																																																																																																																																																																																																																																																				
0 t											0 t - 640 t																																																																																																																																																																																																																																																																																																																																																																																																																																				
85° 85° 75° 65° 55° 45°																																																																																																																																																																																																																																																																																																																																																																																																																																															
m	t	t	t	t	t	t	t	t	t	t	t																																																																																																																																																																																																																																																																																																																																																																																																																																				
22	-	362,0*	-	-	-	-	-	-	-	-	-																																																																																																																																																																																																																																																																																																																																																																																																																																				
24	-	358,0*	-	-	-	-	-	-	-	-	-																																																																																																																																																																																																																																																																																																																																																																																																																																				
26	-	349,0*	-	-	-	-	-	-	-	-	-																																																																																																																																																																																																																																																																																																																																																																																																																																				
28	-	340,0	-	-	-	-	-	-	-	-	-																																																																																																																																																																																																																																																																																																																																																																																																																																				
30	186,0	377,0	-	-	-	-	-	-	-	368,0	-																																																																																																																																																																																																																																																																																																																																																																																																																																				
34	163,0	364,0	-	-	-	-	-	-	-	368,0	-																																																																																																																																																																																																																																																																																																																																																																																																																																				
38	145,0	351,0	-	-	-	-	-	-	-	368,0	-																																																																																																																																																																																																																																																																																																																																																																																																																																				
42	129,0	338,0	-	-	-	-	-	-	-	368,0	-																																																																																																																																																																																																																																																																																																																																																																																																																																				
46	116,0	326,0	-	-	-	-	-	-	-	367,0	-																																																																																																																																																																																																																																																																																																																																																																																																																																				
50	103,0	292,0	386,0	-	-	-	-	-	-	355,0	-																																																																																																																																																																																																																																																																																																																																																																																																																																				
54	92,0	260,0	379,0	-	-	-	-	-	-	339,0	-																																																																																																																																																																																																																																																																																																																																																																																																																																				
56	87,0	240,0	370,0	-	-	-	-	-	-	333,0	-																																																																																																																																																																																																																																																																																																																																																																																																																																				
58	-	-	348,0	-	-	-	-	-	-	327,0	-																																																																																																																																																																																																																																																																																																																																																																																																																																				
62	-	-	305,0	-	-	-	-	-	-	310,0	-																																																																																																																																																																																																																																																																																																																																																																																																																																				
66	-	-	271,0	-	-	-	-	-	-	284,0	-																																																																																																																																																																																																																																																																																																																																																																																																																																				
68	-	-	257,0	-	-	-	-	-	-	272,0	-																																																																																																																																																																																																																																																																																																																																																																																																																																				
69	-	-	-	268,0	-	-	-	-	-	266,0	-																																																																																																																																																																																																																																																																																																																																																																																																																																				
70	-	-	-	264,0	-	-	-	-	-	260,0	-																																																																																																																																																																																																																																																																																																																																																																																																																																				
74	-	-	-	247,0	-	-	-	-	-	239,0	-																																																																																																																																																																																																																																																																																																																																																																																																																																				
78	-	-	-	232,0	-	-	-	-	-	220,0	-																																																																																																																																																																																																																																																																																																																																																																																																																																				
82	-	-	-	219,0	-	-	-	-	-	203,0	-																																																																																																																																																																																																																																																																																																																																																																																																																																				
86	-	-	-	-	-	-	-	-	-	188,0	-																																																																																																																																																																																																																																																																																																																																																																																																																																				
87	-	-	-	-	-	187,0	-	-	-	184,5	-																																																																																																																																																																																																																																																																																																																																																																																																																																				
90	-	-	-	-	-	179,0	-	-	-	174,0	-																																																																																																																																																																																																																																																																																																																																																																																																																																				
94	-	-	-	-	-	170,0	-	-	-	161,0	-																																																																																																																																																																																																																																																																																																																																																																																																																																				
98	-	-	-	-	-	-	-	-	-	144,0	-																																																																																																																																																																																																																																																																																																																																																																																																																																				
102	-	-	-	-	-	-	-	-	131,0	128,0	-																																																																																																																																																																																																																																																																																																																																																																																																																																				
104	-	-	-	-	-	-	-	-	127,0	120,5	-																																																																																																																																																																																																																																																																																																																																																																																																																																				
106	-	-	-	-	-	-	-	-	-	113,0	-																																																																																																																																																																																																																																																																																																																																																																																																																																				
110	-	-	-	-	-	-	-	-	-	98,5	-																																																																																																																																																																																																																																																																																																																																																																																																																																				
114	-	-	-	-	-	-	-	-	-	89,5	-																																																																																																																																																																																																																																																																																																																																																																																																																																				

6 m steps of luffing jib is standard · 6 m Stufung der Wippe ist Standard · Des paliers de 6 m sont de série pour la fléchette

Main boom angle 88°, 85°, 75°, 65°, 55° and 45°; capacities for intermediate boom positions are calculated by the crane control system IC-1  
 Hauptauslegerwinkel 88°, 85°, 75°, 65°, 55° und 45°; Traglasten für Zwischenstellungen des Hauptauslegers werden von der Kransteuerung IC-1 berechnet

Jarret de flèche principale 88°, 85°, 75°, 65°, 55° et 45° ; le système de commande de la grue IC-1 calcule les charges pour les positions intermédiaires de la flèche

\* Main boom angle 88° · Hauptauslegerwinkel 88° · Jarret de flèche principale 88°

295 t + 60 t ZB		19-30 m		10,5 m		9.8 m/s		360°		ISO																																																																																																																																																																																																																																																																																																																																																																																																																																																																									
78 m + 60 m						78 m + 72 m																																																																																																																																																																																																																																																																																																																																																																																																																																																																													
<table border="1"> <thead> <tr> <th colspan="11">SWSL</th> <th>SFSL</th> </tr> <tr> <th colspan="12">0 t - 640 t</th> </tr> <tr> <th></th> <th>85°</th> <th>85°</th> <th>75°</th> <th>65°</th> <th>55°</th> <th>45°</th> <th colspan="5"></th> </tr> <tr> <th>m</th> <th>t</th> <th>t</th> <th>t</th> <th>t</th> <th>t</th> <th>t</th> <th>t</th> <th>t</th> <th>t</th> <th>t</th> <th>t</th> </tr> </thead> <tbody> <tr><td>26</td><td>-</td><td>293,0*</td><td>-</td><td>-</td><td>-</td><td>-</td><td>-</td><td>-</td><td>-</td><td>-</td><td>-</td></tr> <tr><td>28</td><td>-</td><td>290,0*</td><td>-</td><td>-</td><td>-</td><td>-</td><td>-</td><td>-</td><td>-</td><td>-</td><td>-</td></tr> <tr><td>30</td><td>-</td><td>285,0*</td><td>-</td><td>-</td><td>-</td><td>-</td><td>-</td><td>-</td><td>-</td><td>-</td><td>-</td></tr> <tr><td>34</td><td>153,0</td><td>307,0</td><td>-</td><td>-</td><td>-</td><td>-</td><td>-</td><td>-</td><td>-</td><td>299,0</td><td>-</td></tr> <tr><td>38</td><td>135,0</td><td>298,0</td><td>-</td><td>-</td><td>-</td><td>-</td><td>-</td><td>-</td><td>-</td><td>299,0</td><td>-</td></tr> <tr><td>42</td><td>120,0</td><td>290,0</td><td>-</td><td>-</td><td>-</td><td>-</td><td>-</td><td>-</td><td>-</td><td>299,0</td><td>-</td></tr> <tr><td>46</td><td>108,0</td><td>282,0</td><td>-</td><td>-</td><td>-</td><td>-</td><td>-</td><td>-</td><td>-</td><td>299,0</td><td>-</td></tr> <tr><td>50</td><td>97,5</td><td>273,0</td><td>-</td><td>-</td><td>-</td><td>-</td><td>-</td><td>-</td><td>-</td><td>299,0</td><td>-</td></tr> <tr><td>54</td><td>88,0</td><td>265,0</td><td>-</td><td>-</td><td>-</td><td>-</td><td>-</td><td>-</td><td>-</td><td>293,0</td><td>-</td></tr> <tr><td>56</td><td>84,0</td><td>259,0</td><td>314,0</td><td>-</td><td>-</td><td>-</td><td>-</td><td>-</td><td>-</td><td>288,5</td><td>-</td></tr> <tr><td>58</td><td>80,0</td><td>246,0</td><td>313,0</td><td>-</td><td>-</td><td>-</td><td>-</td><td>-</td><td>-</td><td>284,0</td><td>-</td></tr> <tr><td>62</td><td>73,0</td><td>222,0</td><td>307,0</td><td>-</td><td>-</td><td>-</td><td>-</td><td>-</td><td>-</td><td>273,0</td><td>-</td></tr> <tr><td>66</td><td>65,5</td><td>195,0</td><td>285,0</td><td>-</td><td>-</td><td>-</td><td>-</td><td>-</td><td>-</td><td>265,0</td><td>-</td></tr> <tr><td>70</td><td>-</td><td>-</td><td>255,0</td><td>-</td><td>-</td><td>-</td><td>-</td><td>-</td><td>-</td><td>257,0</td><td>-</td></tr> <tr><td>74</td><td>-</td><td>-</td><td>231,0</td><td>-</td><td>-</td><td>-</td><td>-</td><td>-</td><td>-</td><td>245,0</td><td>-</td></tr> <tr><td>77</td><td>-</td><td>-</td><td>215,0</td><td>233,0</td><td>-</td><td>-</td><td>-</td><td>-</td><td>-</td><td>230,7</td><td>-</td></tr> <tr><td>78</td><td>-</td><td>-</td><td>210,0</td><td>229,0</td><td>-</td><td>-</td><td>-</td><td>-</td><td>-</td><td>226,0</td><td>-</td></tr> <tr><td>80</td><td>-</td><td>-</td><td>200,0</td><td>222,0</td><td>-</td><td>-</td><td>-</td><td>-</td><td>-</td><td>217,5</td><td>-</td></tr> <tr><td>82</td><td>-</td><td>-</td><td>-</td><td>216,0</td><td>-</td><td>-</td><td>-</td><td>-</td><td>-</td><td>209,0</td><td>-</td></tr> <tr><td>86</td><td>-</td><td>-</td><td>-</td><td>204,0</td><td>-</td><td>-</td><td>-</td><td>-</td><td>-</td><td>193,0</td><td>-</td></tr> <tr><td>90</td><td>-</td><td>-</td><td>-</td><td>193,0</td><td>-</td><td>-</td><td>-</td><td>-</td><td>-</td><td>179,0</td><td>-</td></tr> <tr><td>94</td><td>-</td><td>-</td><td>-</td><td>183,0</td><td>-</td><td>-</td><td>-</td><td>-</td><td>-</td><td>166,0</td><td>-</td></tr> <tr><td>96</td><td>-</td><td>-</td><td>-</td><td>-</td><td>162,0</td><td>-</td><td>-</td><td>-</td><td>-</td><td>160,0</td><td>-</td></tr> <tr><td>98</td><td>-</td><td>-</td><td>-</td><td>-</td><td>158,0</td><td>-</td><td>-</td><td>-</td><td>-</td><td>154,0</td><td>-</td></tr> <tr><td>102</td><td>-</td><td>-</td><td>-</td><td>-</td><td>150,0</td><td>-</td><td>-</td><td>-</td><td>-</td><td>144,0</td><td>-</td></tr> <tr><td>104</td><td>-</td><td>-</td><td>-</td><td>-</td><td>146,0</td><td>-</td><td>-</td><td>-</td><td>-</td><td>137,0</td><td>-</td></tr> <tr><td>106</td><td>-</td><td>-</td><td>-</td><td>-</td><td>-</td><td>-</td><td>-</td><td>-</td><td>-</td><td>130,0</td><td>-</td></tr> <tr><td>110</td><td>-</td><td>-</td><td>-</td><td>-</td><td>-</td><td>-</td><td>-</td><td>-</td><td>-</td><td>116,0</td><td>-</td></tr> <tr><td>112</td><td>-</td><td>-</td><td>-</td><td>-</td><td>-</td><td>111,0</td><td>-</td><td>-</td><td>-</td><td>109,5</td><td>-</td></tr> <tr><td>114</td><td>-</td><td>-</td><td>-</td><td>-</td><td>-</td><td>108,0</td><td>-</td><td>-</td><td>-</td><td>103,0</td><td>-</td></tr> <tr><td>116</td><td>-</td><td>-</td><td>-</td><td>-</td><td>-</td><td>105,0</td><td>-</td><td>-</td><td>-</td><td>96,5</td><td>-</td></tr> <tr><td>118</td><td>-</td><td>-</td><td>-</td><td>-</td><td>-</td><td>-</td><td>-</td><td>-</td><td>-</td><td>90,0</td><td>-</td></tr> <tr><td>122</td><td>-</td><td>-</td><td>-</td><td>-</td><td>-</td><td>-</td><td>-</td><td>-</td><td>-</td><td>78,5</td><td>-</td></tr> <tr><td>126</td><td>-</td><td>-</td><td>-</td><td>-</td><td>-</td><td>-</td><td>-</td><td>-</td><td>-</td><td>72,5</td><td>-</td></tr> </tbody> </table>												SWSL											SFSL	0 t - 640 t													85°	85°	75°	65°	55°	45°						m	t	t	t	t	t	t	t	t	t	t	t	26	-	293,0*	-	-	-	-	-	-	-	-	-	28	-	290,0*	-	-	-	-	-	-	-	-	-	30	-	285,0*	-	-	-	-	-	-	-	-	-	34	153,0	307,0	-	-	-	-	-	-	-	299,0	-	38	135,0	298,0	-	-	-	-	-	-	-	299,0	-	42	120,0	290,0	-	-	-	-	-	-	-	299,0	-	46	108,0	282,0	-	-	-	-	-	-	-	299,0	-	50	97,5	273,0	-	-	-	-	-	-	-	299,0	-	54	88,0	265,0	-	-	-	-	-	-	-	293,0	-	56	84,0	259,0	314,0	-	-	-	-	-	-	288,5	-	58	80,0	246,0	313,0	-	-	-	-	-	-	284,0	-	62	73,0	222,0	307,0	-	-	-	-	-	-	273,0	-	66	65,5	195,0	285,0	-	-	-	-	-	-	265,0	-	70	-	-	255,0	-	-	-	-	-	-	257,0	-	74	-	-	231,0	-	-	-	-	-	-	245,0	-	77	-	-	215,0	233,0	-	-	-	-	-	230,7	-	78	-	-	210,0	229,0	-	-	-	-	-	226,0	-	80	-	-	200,0	222,0	-	-	-	-	-	217,5	-	82	-	-	-	216,0	-	-	-	-	-	209,0	-	86	-	-	-	204,0	-	-	-	-	-	193,0	-	90	-	-	-	193,0	-	-	-	-	-	179,0	-	94	-	-	-	183,0	-	-	-	-	-	166,0	-	96	-	-	-	-	162,0	-	-	-	-	160,0	-	98	-	-	-	-	158,0	-	-	-	-	154,0	-	102	-	-	-	-	150,0	-	-	-	-	144,0	-	104	-	-	-	-	146,0	-	-	-	-	137,0	-	106	-	-	-	-	-	-	-	-	-	130,0	-	110	-	-	-	-	-	-	-	-	-	116,0	-	112	-	-	-	-	-	111,0	-	-	-	109,5	-	114	-	-	-	-	-	108,0	-	-	-	103,0	-	116	-	-	-	-	-	105,0	-	-	-	96,5	-	118	-	-	-	-	-	-	-	-	-	90,0	-	122	-	-	-	-	-	-	-	-	-	78,5	-	126	-	-	-	-	-	-	-	-	-	72,5	-
SWSL											SFSL																																																																																																																																																																																																																																																																																																																																																																																																																																																																								
0 t - 640 t																																																																																																																																																																																																																																																																																																																																																																																																																																																																																			
	85°	85°	75°	65°	55°	45°																																																																																																																																																																																																																																																																																																																																																																																																																																																																													
m	t	t	t	t	t	t	t	t	t	t	t																																																																																																																																																																																																																																																																																																																																																																																																																																																																								
26	-	293,0*	-	-	-	-	-	-	-	-	-																																																																																																																																																																																																																																																																																																																																																																																																																																																																								
28	-	290,0*	-	-	-	-	-	-	-	-	-																																																																																																																																																																																																																																																																																																																																																																																																																																																																								
30	-	285,0*	-	-	-	-	-	-	-	-	-																																																																																																																																																																																																																																																																																																																																																																																																																																																																								
34	153,0	307,0	-	-	-	-	-	-	-	299,0	-																																																																																																																																																																																																																																																																																																																																																																																																																																																																								
38	135,0	298,0	-	-	-	-	-	-	-	299,0	-																																																																																																																																																																																																																																																																																																																																																																																																																																																																								
42	120,0	290,0	-	-	-	-	-	-	-	299,0	-																																																																																																																																																																																																																																																																																																																																																																																																																																																																								
46	108,0	282,0	-	-	-	-	-	-	-	299,0	-																																																																																																																																																																																																																																																																																																																																																																																																																																																																								
50	97,5	273,0	-	-	-	-	-	-	-	299,0	-																																																																																																																																																																																																																																																																																																																																																																																																																																																																								
54	88,0	265,0	-	-	-	-	-	-	-	293,0	-																																																																																																																																																																																																																																																																																																																																																																																																																																																																								
56	84,0	259,0	314,0	-	-	-	-	-	-	288,5	-																																																																																																																																																																																																																																																																																																																																																																																																																																																																								
58	80,0	246,0	313,0	-	-	-	-	-	-	284,0	-																																																																																																																																																																																																																																																																																																																																																																																																																																																																								
62	73,0	222,0	307,0	-	-	-	-	-	-	273,0	-																																																																																																																																																																																																																																																																																																																																																																																																																																																																								
66	65,5	195,0	285,0	-	-	-	-	-	-	265,0	-																																																																																																																																																																																																																																																																																																																																																																																																																																																																								
70	-	-	255,0	-	-	-	-	-	-	257,0	-																																																																																																																																																																																																																																																																																																																																																																																																																																																																								
74	-	-	231,0	-	-	-	-	-	-	245,0	-																																																																																																																																																																																																																																																																																																																																																																																																																																																																								
77	-	-	215,0	233,0	-	-	-	-	-	230,7	-																																																																																																																																																																																																																																																																																																																																																																																																																																																																								
78	-	-	210,0	229,0	-	-	-	-	-	226,0	-																																																																																																																																																																																																																																																																																																																																																																																																																																																																								
80	-	-	200,0	222,0	-	-	-	-	-	217,5	-																																																																																																																																																																																																																																																																																																																																																																																																																																																																								
82	-	-	-	216,0	-	-	-	-	-	209,0	-																																																																																																																																																																																																																																																																																																																																																																																																																																																																								
86	-	-	-	204,0	-	-	-	-	-	193,0	-																																																																																																																																																																																																																																																																																																																																																																																																																																																																								
90	-	-	-	193,0	-	-	-	-	-	179,0	-																																																																																																																																																																																																																																																																																																																																																																																																																																																																								
94	-	-	-	183,0	-	-	-	-	-	166,0	-																																																																																																																																																																																																																																																																																																																																																																																																																																																																								
96	-	-	-	-	162,0	-	-	-	-	160,0	-																																																																																																																																																																																																																																																																																																																																																																																																																																																																								
98	-	-	-	-	158,0	-	-	-	-	154,0	-																																																																																																																																																																																																																																																																																																																																																																																																																																																																								
102	-	-	-	-	150,0	-	-	-	-	144,0	-																																																																																																																																																																																																																																																																																																																																																																																																																																																																								
104	-	-	-	-	146,0	-	-	-	-	137,0	-																																																																																																																																																																																																																																																																																																																																																																																																																																																																								
106	-	-	-	-	-	-	-	-	-	130,0	-																																																																																																																																																																																																																																																																																																																																																																																																																																																																								
110	-	-	-	-	-	-	-	-	-	116,0	-																																																																																																																																																																																																																																																																																																																																																																																																																																																																								
112	-	-	-	-	-	111,0	-	-	-	109,5	-																																																																																																																																																																																																																																																																																																																																																																																																																																																																								
114	-	-	-	-	-	108,0	-	-	-	103,0	-																																																																																																																																																																																																																																																																																																																																																																																																																																																																								
116	-	-	-	-	-	105,0	-	-	-	96,5	-																																																																																																																																																																																																																																																																																																																																																																																																																																																																								
118	-	-	-	-	-	-	-	-	-	90,0	-																																																																																																																																																																																																																																																																																																																																																																																																																																																																								
122	-	-	-	-	-	-	-	-	-	78,5	-																																																																																																																																																																																																																																																																																																																																																																																																																																																																								
126	-	-	-	-	-	-	-	-	-	72,5	-																																																																																																																																																																																																																																																																																																																																																																																																																																																																								
<table border="1"> <thead> <tr> <th colspan="11">SWSL</th> <th>SFSL</th> </tr> <tr> <th colspan="12">0 t - 640 t</th> </tr> <tr> <th></th> <th>85°</th> <th>85°</th> <th>75°</th> <th>65°</th> <th>55°</th> <th>45°</th> <th colspan="5"></th> </tr> <tr> <th>m</th> <th>t</th> <th>t</th> <th>t</th> <th>t</th> <th>t</th> <th>t</th> <th>t</th> <th>t</th> <th>t</th> <th>t</th> <th>t</th> </tr> </thead> <tbody> <tr><td>30</td><td>-</td><td>240,0*</td><td>-</td><td>-</td><td>-</td><td>-</td><td>-</td><td>-</td><td>-</td><td>-</td><td>-</td></tr> <tr><td>34</td><td>-</td><td>233,0*</td><td>-</td><td>-</td><td>-</td><td>-</td><td>-</td><td>-</td><td>-</td><td>-</td><td>-</td></tr> <tr><td>38</td><td>126,0</td><td>250,0</td><td>-</td><td>-</td><td>-</td><td>-</td><td>-</td><td>-</td><td>-</td><td>243,0</td><td>-</td></tr> <tr><td>42</td><td>112,0</td><td>244,0</td><td>-</td><td>-</td><td>-</td><td>-</td><td>-</td><td>-</td><td>-</td><td>243,0</td><td>-</td></tr> <tr><td>46</td><td>100,0</td><td>239,0</td><td>-</td><td>-</td><td>-</td><td>-</td><td>-</td><td>-</td><td>-</td><td>243,0</td><td>-</td></tr> <tr><td>50</td><td>89,5</td><td>233,0</td><td>-</td><td>-</td><td>-</td><td>-</td><td>-</td><td>-</td><td>-</td><td>243,0</td><td>-</td></tr> <tr><td>54</td><td>81,0</td><td>228,0</td><td>-</td><td>-</td><td>-</td><td>-</td><td>-</td><td>-</td><td>-</td><td>243,0</td><td>-</td></tr> <tr><td>58</td><td>73,0</td><td>222,0</td><td>-</td><td>-</td><td>-</td><td>-</td><td>-</td><td>-</td><td>-</td><td>241,0</td><td>-</td></tr> <tr><td>62</td><td>66,0</td><td>217,0</td><td>254,0</td><td>-</td><td>-</td><td>-</td><td>-</td><td>-</td><td>-</td><td>235,0</td><td>-</td></tr> <tr><td>66</td><td>60,0</td><td>207,0</td><td>254,0</td><td>-</td><td>-</td><td>-</td><td>-</td><td>-</td><td>-</td><td>230,0</td><td>-</td></tr> <tr><td>70</td><td>54,5</td><td>189,0</td><td>250,0</td><td>-</td><td>-</td><td>-</td><td>-</td><td>-</td><td>-</td><td>224,0</td><td>-</td></tr> <tr><td>74</td><td>49,3</td><td>166,0</td><td>236,0</td><td>-</td><td>-</td><td>-</td><td>-</td><td>-</td><td>-</td><td>216,0</td><td>-</td></tr> <tr><td>78</td><td>44,1</td><td>143,0</td><td>214,0</td><td>-</td><td>-</td><td>-</td><td>-</td><td>-</td><td>-</td><td>211,0</td><td>-</td></tr> <tr><td>82</td><td>-</td><td>-</td><td>196,0</td><td>-</td><td>-</td><td>-</td><td>-</td><td>-</td><td>-</td><td>205,0</td><td>-</td></tr> <tr><td>86</td><td>-</td><td>-</td><td>179,0</td><td>198,0</td><td>-</td><td>-</td><td>-</td><td>-</td><td>-</td><td>195,0</td><td>-</td></tr> <tr><td>90</td><td>-</td><td>-</td><td>163,0</td><td>187,0</td><td>-</td><td>-</td><td>-</td><td>-</td><td>-</td><td>181,0</td><td>-</td></tr> <tr><td>92</td><td>-</td><td>-</td><td>152,0</td><td>182,0</td><td>-</td><td>-</td><td>-</td><td>-</td><td>-</td><td>174,5</td><td>-</td></tr> <tr><td>94</td><td>-</td><td>-</td><td>-</td><td>177,0</td><td>-</td><td>-</td><td>-</td><td>-</td><td>-</td><td>168,0</td><td>-</td></tr> <tr><td>98</td><td>-</td><td>-</td><td>-</td><td>168,0</td><td>-</td><td>-</td><td>-</td><td>-</td><td>-</td><td>156,0</td><td>-</td></tr> <tr><td>102</td><td>-</td><td>-</td><td>-</td><td>160,0</td><td>-</td><td>-</td><td>-</td><td>-</td><td>-</td><td>145,0</td><td>-</td></tr> <tr><td>104</td><td>-</td><td>-</td><td>-</td><td>156,0</td><td>-</td><td>-</td><td>-</td><td>-</td><td>-</td><td>140,0</td><td>-</td></tr> <tr><td>106</td><td>-</td><td>-</td><td>-</td><td>-</td><td>137,0</td><td>-</td><td>-</td><td>-</td><td>-</td><td>135,0</td><td>-</td></tr> <tr><td>110</td><td>-</td><td>-</td><td>-</td><td>-</td><td>130,0</td><td>-</td><td>-</td><td>-</td><td>-</td><td>125,0</td><td>-</td></tr> <tr><td>114</td><td>-</td><td>-</td><td>-</td><td>-</td><td>124,0</td><td>-</td><td>-</td><td>-</td><td>-</td><td>114,0</td><td>-</td></tr> <tr><td>116</td><td>-</td><td>-</td><td>-</td><td>-</td><td>122,0</td><td>-</td><td>-</td><td>-</td><td>-</td><td>108,0</td><td>-</td></tr> <tr><td>118</td><td>-</td><td>-</td><td>-</td><td>-</td><td>-</td><td>-</td><td>-</td><td>-</td><td>-</td><td>102,0</td><td>-</td></tr> <tr><td>122</td><td>-</td><td>-</td><td>-</td><td>-</td><td>-</td><td>-</td><td>-</td><td>-</td><td>91,5</td><td>90,5</td><td>-</td></tr> <tr><td>126</td><td>-</td><td>-</td><td>-</td><td>-</td><td>-</td><td>-</td><td>-</td><td>-</td><td>86,5</td><td>79,5</td><td>-</td></tr> <tr><td>130</td><td>-</td><td>-</td><td>-</td><td>-</td><td>-</td><td>-</td><td>-</td><td>-</td><td>-</td><td>68,5</td><td>-</td></tr> <tr><td>134</td><td>-</td><td>-</td><td>-</td><td>-</td><td>-</td><td>-</td><td>-</td><td>-</td><td>-</td><td>61,5</td><td>-</td></tr> </tbody> </table>												SWSL											SFSL	0 t - 640 t													85°	85°	75°	65°	55°	45°						m	t	t	t	t	t	t	t	t	t	t	t	30	-	240,0*	-	-	-	-	-	-	-	-	-	34	-	233,0*	-	-	-	-	-	-	-	-	-	38	126,0	250,0	-	-	-	-	-	-	-	243,0	-	42	112,0	244,0	-	-	-	-	-	-	-	243,0	-	46	100,0	239,0	-	-	-	-	-	-	-	243,0	-	50	89,5	233,0	-	-	-	-	-	-	-	243,0	-	54	81,0	228,0	-	-	-	-	-	-	-	243,0	-	58	73,0	222,0	-	-	-	-	-	-	-	241,0	-	62	66,0	217,0	254,0	-	-	-	-	-	-	235,0	-	66	60,0	207,0	254,0	-	-	-	-	-	-	230,0	-	70	54,5	189,0	250,0	-	-	-	-	-	-	224,0	-	74	49,3	166,0	236,0	-	-	-	-	-	-	216,0	-	78	44,1	143,0	214,0	-	-	-	-	-	-	211,0	-	82	-	-	196,0	-	-	-	-	-	-	205,0	-	86	-	-	179,0	198,0	-	-	-	-	-	195,0	-	90	-	-	163,0	187,0	-	-	-	-	-	181,0	-	92	-	-	152,0	182,0	-	-	-	-	-	174,5	-	94	-	-	-	177,0	-	-	-	-	-	168,0	-	98	-	-	-	168,0	-	-	-	-	-	156,0	-	102	-	-	-	160,0	-	-	-	-	-	145,0	-	104	-	-	-	156,0	-	-	-	-	-	140,0	-	106	-	-	-	-	137,0	-	-	-	-	135,0	-	110	-	-	-	-	130,0	-	-	-	-	125,0	-	114	-	-	-	-	124,0	-	-	-	-	114,0	-	116	-	-	-	-	122,0	-	-	-	-	108,0	-	118	-	-	-	-	-	-	-	-	-	102,0	-	122	-	-	-	-	-	-	-	-	91,5	90,5	-	126	-	-	-	-	-	-	-	-	86,5	79,5	-	130	-	-	-	-	-	-	-	-	-	68,5	-	134	-	-	-	-	-	-	-	-	-	61,5	-																																																
SWSL											SFSL																																																																																																																																																																																																																																																																																																																																																																																																																																																																								
0 t - 640 t																																																																																																																																																																																																																																																																																																																																																																																																																																																																																			
	85°	85°	75°	65°	55°	45°																																																																																																																																																																																																																																																																																																																																																																																																																																																																													
m	t	t	t	t	t	t	t	t	t	t	t																																																																																																																																																																																																																																																																																																																																																																																																																																																																								
30	-	240,0*	-	-	-	-	-	-	-	-	-																																																																																																																																																																																																																																																																																																																																																																																																																																																																								
34	-	233,0*	-	-	-	-	-	-	-	-	-																																																																																																																																																																																																																																																																																																																																																																																																																																																																								
38	126,0	250,0	-	-	-	-	-	-	-	243,0	-																																																																																																																																																																																																																																																																																																																																																																																																																																																																								
42	112,0	244,0	-	-	-	-	-	-	-	243,0	-																																																																																																																																																																																																																																																																																																																																																																																																																																																																								
46	100,0	239,0	-	-	-	-	-	-	-	243,0	-																																																																																																																																																																																																																																																																																																																																																																																																																																																																								
50	89,5	233,0	-	-	-	-	-	-	-	243,0	-																																																																																																																																																																																																																																																																																																																																																																																																																																																																								
54	81,0	228,0	-	-	-	-	-	-	-	243,0	-																																																																																																																																																																																																																																																																																																																																																																																																																																																																								
58	73,0	222,0	-	-	-	-	-	-	-	241,0	-																																																																																																																																																																																																																																																																																																																																																																																																																																																																								
62	66,0	217,0	254,0	-	-	-	-	-	-	235,0	-																																																																																																																																																																																																																																																																																																																																																																																																																																																																								
66	60,0	207,0	254,0	-	-	-	-	-	-	230,0	-																																																																																																																																																																																																																																																																																																																																																																																																																																																																								
70	54,5	189,0	250,0	-	-	-	-	-	-	224,0	-																																																																																																																																																																																																																																																																																																																																																																																																																																																																								
74	49,3	166,0	236,0	-	-	-	-	-	-	216,0	-																																																																																																																																																																																																																																																																																																																																																																																																																																																																								
78	44,1	143,0	214,0	-	-	-	-	-	-	211,0	-																																																																																																																																																																																																																																																																																																																																																																																																																																																																								
82	-	-	196,0	-	-	-	-	-	-	205,0	-																																																																																																																																																																																																																																																																																																																																																																																																																																																																								
86	-	-	179,0	198,0	-	-	-	-	-	195,0	-																																																																																																																																																																																																																																																																																																																																																																																																																																																																								
90	-	-	163,0	187,0	-	-	-	-	-	181,0	-																																																																																																																																																																																																																																																																																																																																																																																																																																																																								
92	-	-	152,0	182,0	-	-	-	-	-	174,5	-																																																																																																																																																																																																																																																																																																																																																																																																																																																																								
94	-	-	-	177,0	-	-	-	-	-	168,0	-																																																																																																																																																																																																																																																																																																																																																																																																																																																																								
98	-	-	-	168,0	-	-	-	-	-	156,0	-																																																																																																																																																																																																																																																																																																																																																																																																																																																																								
102	-	-	-	160,0	-	-	-	-	-	145,0	-																																																																																																																																																																																																																																																																																																																																																																																																																																																																								
104	-	-	-	156,0	-	-	-	-	-	140,0	-																																																																																																																																																																																																																																																																																																																																																																																																																																																																								
106	-	-	-	-	137,0	-	-	-	-	135,0	-																																																																																																																																																																																																																																																																																																																																																																																																																																																																								
110	-	-	-	-	130,0	-	-	-	-	125,0	-																																																																																																																																																																																																																																																																																																																																																																																																																																																																								
114	-	-	-	-	124,0	-	-	-	-	114,0	-																																																																																																																																																																																																																																																																																																																																																																																																																																																																								
116	-	-	-	-	122,0	-	-	-	-	108,0	-																																																																																																																																																																																																																																																																																																																																																																																																																																																																								
118	-	-	-	-	-	-	-	-	-	102,0	-																																																																																																																																																																																																																																																																																																																																																																																																																																																																								
122	-	-	-	-	-	-	-	-	91,5	90,5	-																																																																																																																																																																																																																																																																																																																																																																																																																																																																								
126	-	-	-	-	-	-	-	-	86,5	79,5	-																																																																																																																																																																																																																																																																																																																																																																																																																																																																								
130	-	-	-	-	-	-	-	-	-	68,5	-																																																																																																																																																																																																																																																																																																																																																																																																																																																																								
134	-	-	-	-	-	-	-	-	-	61,5	-																																																																																																																																																																																																																																																																																																																																																																																																																																																																								

6 m steps of luffing jib is standard · 6 m Stufung der Wippe ist Standard · Des paliers de 6 m sont de série pour la fléchette

Main boom angle 88°, 85°, 75°, 65°, 55° and 45°; capacities for intermediate boom positions are calculated by the crane control system IC-1  
 Hauptauslegerwinkel 88°, 85°, 75°, 65°, 55° und 45°; Traglasten für Zwischenstellungen des Hauptauslegers werden von der Kransteuerung IC-1 berechnet

Jarret de flèche principale 88°, 85°, 75°, 65°, 55° et 45° ; le système de commande de la grue IC-1 calcule les charges pour les positions intermédiaires de la flèche

\* Main boom angle 88° · Hauptauslegerwinkel 88° · Jarret de flèche principale 88°

295 t + 60 t ZB		19-30 m		10,5 m		9.8 m/s		360°		ISO																																																																																																																																																																																																																																																																																																																																							
78 m + 84 m						78 m + 96 m																																																																																																																																																																																																																																																																																																																																											
<table border="1"> <thead> <tr> <th rowspan="3">m</th> <th colspan="6">SWSL</th> <th>SFSL</th> </tr> <tr> <th colspan="2">0 t</th> <th colspan="4">0 t - 640 t</th> <th></th> </tr> <tr> <th>85°</th> <th>85°</th> <th>75°</th> <th>65°</th> <th>55°</th> <th>45°</th> <th>t</th> </tr> </thead> <tbody> <tr><td>34</td><td>-</td><td>195,0*</td><td>-</td><td>-</td><td>-</td><td>-</td><td>-</td></tr> <tr><td>38</td><td>-</td><td>190,0*</td><td>-</td><td>-</td><td>-</td><td>-</td><td>-</td></tr> <tr><td>42</td><td>101,0</td><td>202,0</td><td>-</td><td>-</td><td>-</td><td>-</td><td>198,0</td></tr> <tr><td>46</td><td>89,5</td><td>199,0</td><td>-</td><td>-</td><td>-</td><td>-</td><td>198,0</td></tr> <tr><td>50</td><td>79,5</td><td>195,0</td><td>-</td><td>-</td><td>-</td><td>-</td><td>198,0</td></tr> <tr><td>54</td><td>71,0</td><td>192,0</td><td>-</td><td>-</td><td>-</td><td>-</td><td>198,0</td></tr> <tr><td>58</td><td>63,5</td><td>188,0</td><td>-</td><td>-</td><td>-</td><td>-</td><td>198,0</td></tr> <tr><td>62</td><td>57,0</td><td>184,0</td><td>-</td><td>-</td><td>-</td><td>-</td><td>197,0</td></tr> <tr><td>66</td><td>51,0</td><td>180,0</td><td>-</td><td>-</td><td>-</td><td>-</td><td>194,0</td></tr> <tr><td>68</td><td>48,5</td><td>179,0</td><td>202,0</td><td>-</td><td>-</td><td>-</td><td>192,0</td></tr> <tr><td>70</td><td>45,8</td><td>177,0</td><td>202,0</td><td>-</td><td>-</td><td>-</td><td>190,0</td></tr> <tr><td>74</td><td>41,1</td><td>168,0</td><td>202,0</td><td>-</td><td>-</td><td>-</td><td>187,0</td></tr> <tr><td>78</td><td>36,7</td><td>154,0</td><td>202,0</td><td>-</td><td>-</td><td>-</td><td>183,0</td></tr> <tr><td>82</td><td>32,4</td><td>139,5</td><td>190,0</td><td>-</td><td>-</td><td>-</td><td>178,0</td></tr> <tr><td>86</td><td>28,3</td><td>123,0</td><td>174,0</td><td>-</td><td>-</td><td>-</td><td>174,0</td></tr> <tr><td>88</td><td>26,4</td><td>115,0</td><td>166,0</td><td>-</td><td>-</td><td>-</td><td>172,0</td></tr> <tr><td>90</td><td>-</td><td>-</td><td>159,0</td><td>-</td><td>-</td><td>-</td><td>170,0</td></tr> <tr><td>92</td><td>-</td><td>-</td><td>153,0</td><td>173,0</td><td>-</td><td>-</td><td>167,5</td></tr> <tr><td>94</td><td>-</td><td>-</td><td>147,0</td><td>168,0</td><td>-</td><td>-</td><td>165,0</td></tr> <tr><td>98</td><td>-</td><td>-</td><td>135,0</td><td>159,0</td><td>-</td><td>-</td><td>153,0</td></tr> <tr><td>102</td><td>-</td><td>-</td><td>122,0</td><td>151,0</td><td>-</td><td>-</td><td>142,0</td></tr> <tr><td>104</td><td>-</td><td>-</td><td>114,0</td><td>147,0</td><td>-</td><td>-</td><td>137,0</td></tr> <tr><td>106</td><td>-</td><td>-</td><td>-</td><td>143,0</td><td>-</td><td>-</td><td>132,0</td></tr> <tr><td>110</td><td>-</td><td>-</td><td>-</td><td>136,0</td><td>-</td><td>-</td><td>123,0</td></tr> <tr><td>114</td><td>-</td><td>-</td><td>-</td><td>128,0</td><td>115,0</td><td>-</td><td>114,0</td></tr> <tr><td>116</td><td>-</td><td>-</td><td>-</td><td>123,0</td><td>112,0</td><td>-</td><td>109,5</td></tr> <tr><td>118</td><td>-</td><td>-</td><td>-</td><td>-</td><td>110,0</td><td>-</td><td>105,0</td></tr> <tr><td>122</td><td>-</td><td>-</td><td>-</td><td>-</td><td>104,0</td><td>-</td><td>95,0</td></tr> <tr><td>126</td><td>-</td><td>-</td><td>-</td><td>-</td><td>100,0</td><td>-</td><td>84,5</td></tr> <tr><td>128</td><td>-</td><td>-</td><td>-</td><td>-</td><td>98,0</td><td>-</td><td>79,5</td></tr> <tr><td>130</td><td>-</td><td>-</td><td>-</td><td>-</td><td>-</td><td>-</td><td>74,5</td></tr> <tr><td>134</td><td>-</td><td>-</td><td>-</td><td>-</td><td>-</td><td>68,0</td><td>65,0</td></tr> <tr><td>138</td><td>-</td><td>-</td><td>-</td><td>-</td><td>-</td><td>64,5</td><td>55,5</td></tr> <tr><td>142</td><td>-</td><td>-</td><td>-</td><td>-</td><td>-</td><td>-</td><td>48,8</td></tr> <tr><td>146</td><td>-</td><td>-</td><td>-</td><td>-</td><td>-</td><td>-</td><td>44,3</td></tr> </tbody> </table>												m	SWSL						SFSL	0 t		0 t - 640 t					85°	85°	75°	65°	55°	45°	t	34	-	195,0*	-	-	-	-	-	38	-	190,0*	-	-	-	-	-	42	101,0	202,0	-	-	-	-	198,0	46	89,5	199,0	-	-	-	-	198,0	50	79,5	195,0	-	-	-	-	198,0	54	71,0	192,0	-	-	-	-	198,0	58	63,5	188,0	-	-	-	-	198,0	62	57,0	184,0	-	-	-	-	197,0	66	51,0	180,0	-	-	-	-	194,0	68	48,5	179,0	202,0	-	-	-	192,0	70	45,8	177,0	202,0	-	-	-	190,0	74	41,1	168,0	202,0	-	-	-	187,0	78	36,7	154,0	202,0	-	-	-	183,0	82	32,4	139,5	190,0	-	-	-	178,0	86	28,3	123,0	174,0	-	-	-	174,0	88	26,4	115,0	166,0	-	-	-	172,0	90	-	-	159,0	-	-	-	170,0	92	-	-	153,0	173,0	-	-	167,5	94	-	-	147,0	168,0	-	-	165,0	98	-	-	135,0	159,0	-	-	153,0	102	-	-	122,0	151,0	-	-	142,0	104	-	-	114,0	147,0	-	-	137,0	106	-	-	-	143,0	-	-	132,0	110	-	-	-	136,0	-	-	123,0	114	-	-	-	128,0	115,0	-	114,0	116	-	-	-	123,0	112,0	-	109,5	118	-	-	-	-	110,0	-	105,0	122	-	-	-	-	104,0	-	95,0	126	-	-	-	-	100,0	-	84,5	128	-	-	-	-	98,0	-	79,5	130	-	-	-	-	-	-	74,5	134	-	-	-	-	-	68,0	65,0	138	-	-	-	-	-	64,5	55,5	142	-	-	-	-	-	-	48,8	146	-	-	-	-	-	-	44,3																								
m	SWSL						SFSL																																																																																																																																																																																																																																																																																																																																										
	0 t		0 t - 640 t																																																																																																																																																																																																																																																																																																																																														
	85°	85°	75°	65°	55°	45°	t																																																																																																																																																																																																																																																																																																																																										
34	-	195,0*	-	-	-	-	-																																																																																																																																																																																																																																																																																																																																										
38	-	190,0*	-	-	-	-	-																																																																																																																																																																																																																																																																																																																																										
42	101,0	202,0	-	-	-	-	198,0																																																																																																																																																																																																																																																																																																																																										
46	89,5	199,0	-	-	-	-	198,0																																																																																																																																																																																																																																																																																																																																										
50	79,5	195,0	-	-	-	-	198,0																																																																																																																																																																																																																																																																																																																																										
54	71,0	192,0	-	-	-	-	198,0																																																																																																																																																																																																																																																																																																																																										
58	63,5	188,0	-	-	-	-	198,0																																																																																																																																																																																																																																																																																																																																										
62	57,0	184,0	-	-	-	-	197,0																																																																																																																																																																																																																																																																																																																																										
66	51,0	180,0	-	-	-	-	194,0																																																																																																																																																																																																																																																																																																																																										
68	48,5	179,0	202,0	-	-	-	192,0																																																																																																																																																																																																																																																																																																																																										
70	45,8	177,0	202,0	-	-	-	190,0																																																																																																																																																																																																																																																																																																																																										
74	41,1	168,0	202,0	-	-	-	187,0																																																																																																																																																																																																																																																																																																																																										
78	36,7	154,0	202,0	-	-	-	183,0																																																																																																																																																																																																																																																																																																																																										
82	32,4	139,5	190,0	-	-	-	178,0																																																																																																																																																																																																																																																																																																																																										
86	28,3	123,0	174,0	-	-	-	174,0																																																																																																																																																																																																																																																																																																																																										
88	26,4	115,0	166,0	-	-	-	172,0																																																																																																																																																																																																																																																																																																																																										
90	-	-	159,0	-	-	-	170,0																																																																																																																																																																																																																																																																																																																																										
92	-	-	153,0	173,0	-	-	167,5																																																																																																																																																																																																																																																																																																																																										
94	-	-	147,0	168,0	-	-	165,0																																																																																																																																																																																																																																																																																																																																										
98	-	-	135,0	159,0	-	-	153,0																																																																																																																																																																																																																																																																																																																																										
102	-	-	122,0	151,0	-	-	142,0																																																																																																																																																																																																																																																																																																																																										
104	-	-	114,0	147,0	-	-	137,0																																																																																																																																																																																																																																																																																																																																										
106	-	-	-	143,0	-	-	132,0																																																																																																																																																																																																																																																																																																																																										
110	-	-	-	136,0	-	-	123,0																																																																																																																																																																																																																																																																																																																																										
114	-	-	-	128,0	115,0	-	114,0																																																																																																																																																																																																																																																																																																																																										
116	-	-	-	123,0	112,0	-	109,5																																																																																																																																																																																																																																																																																																																																										
118	-	-	-	-	110,0	-	105,0																																																																																																																																																																																																																																																																																																																																										
122	-	-	-	-	104,0	-	95,0																																																																																																																																																																																																																																																																																																																																										
126	-	-	-	-	100,0	-	84,5																																																																																																																																																																																																																																																																																																																																										
128	-	-	-	-	98,0	-	79,5																																																																																																																																																																																																																																																																																																																																										
130	-	-	-	-	-	-	74,5																																																																																																																																																																																																																																																																																																																																										
134	-	-	-	-	-	68,0	65,0																																																																																																																																																																																																																																																																																																																																										
138	-	-	-	-	-	64,5	55,5																																																																																																																																																																																																																																																																																																																																										
142	-	-	-	-	-	-	48,8																																																																																																																																																																																																																																																																																																																																										
146	-	-	-	-	-	-	44,3																																																																																																																																																																																																																																																																																																																																										
<table border="1"> <thead> <tr> <th rowspan="3">m</th> <th colspan="6">SWSL</th> <th>SFSL</th> </tr> <tr> <th colspan="2">0 t</th> <th colspan="4">0 t - 640 t</th> <th></th> </tr> <tr> <th>85°</th> <th>85°</th> <th>75°</th> <th>65°</th> <th>55°</th> <th>45°</th> <th>t</th> </tr> </thead> <tbody> <tr><td>36</td><td>-</td><td>157,0*</td><td>-</td><td>-</td><td>-</td><td>-</td><td>-</td></tr> <tr><td>38</td><td>-</td><td>157,0*</td><td>-</td><td>-</td><td>-</td><td>-</td><td>-</td></tr> <tr><td>42</td><td>-</td><td>153,0*</td><td>-</td><td>-</td><td>-</td><td>-</td><td>-</td></tr> <tr><td>46</td><td>81,5</td><td>162,0</td><td>-</td><td>-</td><td>-</td><td>-</td><td>159,0</td></tr> <tr><td>50</td><td>72,0</td><td>160,0</td><td>-</td><td>-</td><td>-</td><td>-</td><td>159,0</td></tr> <tr><td>54</td><td>63,5</td><td>158,0</td><td>-</td><td>-</td><td>-</td><td>-</td><td>159,0</td></tr> <tr><td>58</td><td>56,5</td><td>156,0</td><td>-</td><td>-</td><td>-</td><td>-</td><td>159,0</td></tr> <tr><td>62</td><td>50,0</td><td>153,0</td><td>-</td><td>-</td><td>-</td><td>-</td><td>159,0</td></tr> <tr><td>66</td><td>44,4</td><td>151,0</td><td>-</td><td>-</td><td>-</td><td>-</td><td>159,0</td></tr> <tr><td>70</td><td>39,3</td><td>148,0</td><td>-</td><td>-</td><td>-</td><td>-</td><td>158,0</td></tr> <tr><td>74</td><td>34,6</td><td>146,0</td><td>158,0</td><td>-</td><td>-</td><td>-</td><td>155,0</td></tr> <tr><td>78</td><td>30,3</td><td>143,0</td><td>158,0</td><td>-</td><td>-</td><td>-</td><td>153,0</td></tr> <tr><td>82</td><td>26,5</td><td>138,0</td><td>158,0</td><td>-</td><td>-</td><td>-</td><td>151,0</td></tr> <tr><td>84</td><td>24,7</td><td>135,0</td><td>158,0</td><td>-</td><td>-</td><td>-</td><td>149,5</td></tr> <tr><td>86</td><td>23,0</td><td>129,5</td><td>158,0</td><td>-</td><td>-</td><td>-</td><td>148,0</td></tr> <tr><td>90</td><td>19,7</td><td>118,5</td><td>158,0</td><td>-</td><td>-</td><td>-</td><td>146,0</td></tr> <tr><td>94</td><td>16,7</td><td>106,5</td><td>145,0</td><td>-</td><td>-</td><td>-</td><td>142,0</td></tr> <tr><td>98</td><td>13,9</td><td>93,7</td><td>134,0</td><td>-</td><td>-</td><td>-</td><td>139,0</td></tr> <tr><td>100</td><td>12,6</td><td>87,5</td><td>128,0</td><td>141,0</td><td>-</td><td>-</td><td>138,0</td></tr> <tr><td>102</td><td>-</td><td>-</td><td>123,0</td><td>141,0</td><td>-</td><td>-</td><td>137,0</td></tr> <tr><td>106</td><td>-</td><td>-</td><td>114,0</td><td>139,0</td><td>-</td><td>-</td><td>133,0</td></tr> <tr><td>110</td><td>-</td><td>-</td><td>106,0</td><td>131,0</td><td>-</td><td>-</td><td>123,0</td></tr> <tr><td>114</td><td>-</td><td>-</td><td>94,5</td><td>125,0</td><td>-</td><td>-</td><td>115,0</td></tr> <tr><td>118</td><td>-</td><td>-</td><td>-</td><td>116,0</td><td>-</td><td>-</td><td>106,0</td></tr> <tr><td>122</td><td>-</td><td>-</td><td>-</td><td>108,0</td><td>-</td><td>-</td><td>99,0</td></tr> <tr><td>124</td><td>-</td><td>-</td><td>-</td><td>104,0</td><td>97,0</td><td>-</td><td>95,0</td></tr> <tr><td>126</td><td>-</td><td>-</td><td>-</td><td>100,0</td><td>94,5</td><td>-</td><td>91,0</td></tr> <tr><td>128</td><td>-</td><td>-</td><td>-</td><td>96,5</td><td>92,0</td><td>-</td><td>86,2</td></tr> <tr><td>130</td><td>-</td><td>-</td><td>-</td><td>-</td><td>90,0</td><td>-</td><td>81,5</td></tr> <tr><td>134</td><td>-</td><td>-</td><td>-</td><td>-</td><td>85,5</td><td>-</td><td>72,5</td></tr> <tr><td>138</td><td>-</td><td>-</td><td>-</td><td>-</td><td>81,0</td><td>-</td><td>63,5</td></tr> <tr><td>140</td><td>-</td><td>-</td><td>-</td><td>-</td><td>79,0</td><td>-</td><td>59,2</td></tr> <tr><td>142</td><td>-</td><td>-</td><td>-</td><td>-</td><td>-</td><td>-</td><td>55,0</td></tr> <tr><td>144</td><td>-</td><td>-</td><td>-</td><td>-</td><td>-</td><td>53,0</td><td>51,0</td></tr> <tr><td>146</td><td>-</td><td>-</td><td>-</td><td>-</td><td>-</td><td>51,5</td><td>47,1</td></tr> <tr><td>150</td><td>-</td><td>-</td><td>-</td><td>-</td><td>-</td><td>48,8</td><td>41,1</td></tr> <tr><td>154</td><td>-</td><td>-</td><td>-</td><td>-</td><td>-</td><td>-</td><td>37,1</td></tr> <tr><td>158</td><td>-</td><td>-</td><td>-</td><td>-</td><td>-</td><td>-</td><td>29,2</td></tr> </tbody> </table>												m	SWSL						SFSL	0 t		0 t - 640 t					85°	85°	75°	65°	55°	45°	t	36	-	157,0*	-	-	-	-	-	38	-	157,0*	-	-	-	-	-	42	-	153,0*	-	-	-	-	-	46	81,5	162,0	-	-	-	-	159,0	50	72,0	160,0	-	-	-	-	159,0	54	63,5	158,0	-	-	-	-	159,0	58	56,5	156,0	-	-	-	-	159,0	62	50,0	153,0	-	-	-	-	159,0	66	44,4	151,0	-	-	-	-	159,0	70	39,3	148,0	-	-	-	-	158,0	74	34,6	146,0	158,0	-	-	-	155,0	78	30,3	143,0	158,0	-	-	-	153,0	82	26,5	138,0	158,0	-	-	-	151,0	84	24,7	135,0	158,0	-	-	-	149,5	86	23,0	129,5	158,0	-	-	-	148,0	90	19,7	118,5	158,0	-	-	-	146,0	94	16,7	106,5	145,0	-	-	-	142,0	98	13,9	93,7	134,0	-	-	-	139,0	100	12,6	87,5	128,0	141,0	-	-	138,0	102	-	-	123,0	141,0	-	-	137,0	106	-	-	114,0	139,0	-	-	133,0	110	-	-	106,0	131,0	-	-	123,0	114	-	-	94,5	125,0	-	-	115,0	118	-	-	-	116,0	-	-	106,0	122	-	-	-	108,0	-	-	99,0	124	-	-	-	104,0	97,0	-	95,0	126	-	-	-	100,0	94,5	-	91,0	128	-	-	-	96,5	92,0	-	86,2	130	-	-	-	-	90,0	-	81,5	134	-	-	-	-	85,5	-	72,5	138	-	-	-	-	81,0	-	63,5	140	-	-	-	-	79,0	-	59,2	142	-	-	-	-	-	-	55,0	144	-	-	-	-	-	53,0	51,0	146	-	-	-	-	-	51,5	47,1	150	-	-	-	-	-	48,8	41,1	154	-	-	-	-	-	-	37,1	158	-	-	-	-	-	-	29,2
m	SWSL						SFSL																																																																																																																																																																																																																																																																																																																																										
	0 t		0 t - 640 t																																																																																																																																																																																																																																																																																																																																														
	85°	85°	75°	65°	55°	45°	t																																																																																																																																																																																																																																																																																																																																										
36	-	157,0*	-	-	-	-	-																																																																																																																																																																																																																																																																																																																																										
38	-	157,0*	-	-	-	-	-																																																																																																																																																																																																																																																																																																																																										
42	-	153,0*	-	-	-	-	-																																																																																																																																																																																																																																																																																																																																										
46	81,5	162,0	-	-	-	-	159,0																																																																																																																																																																																																																																																																																																																																										
50	72,0	160,0	-	-	-	-	159,0																																																																																																																																																																																																																																																																																																																																										
54	63,5	158,0	-	-	-	-	159,0																																																																																																																																																																																																																																																																																																																																										
58	56,5	156,0	-	-	-	-	159,0																																																																																																																																																																																																																																																																																																																																										
62	50,0	153,0	-	-	-	-	159,0																																																																																																																																																																																																																																																																																																																																										
66	44,4	151,0	-	-	-	-	159,0																																																																																																																																																																																																																																																																																																																																										
70	39,3	148,0	-	-	-	-	158,0																																																																																																																																																																																																																																																																																																																																										
74	34,6	146,0	158,0	-	-	-	155,0																																																																																																																																																																																																																																																																																																																																										
78	30,3	143,0	158,0	-	-	-	153,0																																																																																																																																																																																																																																																																																																																																										
82	26,5	138,0	158,0	-	-	-	151,0																																																																																																																																																																																																																																																																																																																																										
84	24,7	135,0	158,0	-	-	-	149,5																																																																																																																																																																																																																																																																																																																																										
86	23,0	129,5	158,0	-	-	-	148,0																																																																																																																																																																																																																																																																																																																																										
90	19,7	118,5	158,0	-	-	-	146,0																																																																																																																																																																																																																																																																																																																																										
94	16,7	106,5	145,0	-	-	-	142,0																																																																																																																																																																																																																																																																																																																																										
98	13,9	93,7	134,0	-	-	-	139,0																																																																																																																																																																																																																																																																																																																																										
100	12,6	87,5	128,0	141,0	-	-	138,0																																																																																																																																																																																																																																																																																																																																										
102	-	-	123,0	141,0	-	-	137,0																																																																																																																																																																																																																																																																																																																																										
106	-	-	114,0	139,0	-	-	133,0																																																																																																																																																																																																																																																																																																																																										
110	-	-	106,0	131,0	-	-	123,0																																																																																																																																																																																																																																																																																																																																										
114	-	-	94,5	125,0	-	-	115,0																																																																																																																																																																																																																																																																																																																																										
118	-	-	-	116,0	-	-	106,0																																																																																																																																																																																																																																																																																																																																										
122	-	-	-	108,0	-	-	99,0																																																																																																																																																																																																																																																																																																																																										
124	-	-	-	104,0	97,0	-	95,0																																																																																																																																																																																																																																																																																																																																										
126	-	-	-	100,0	94,5	-	91,0																																																																																																																																																																																																																																																																																																																																										
128	-	-	-	96,5	92,0	-	86,2																																																																																																																																																																																																																																																																																																																																										
130	-	-	-	-	90,0	-	81,5																																																																																																																																																																																																																																																																																																																																										
134	-	-	-	-	85,5	-	72,5																																																																																																																																																																																																																																																																																																																																										
138	-	-	-	-	81,0	-	63,5																																																																																																																																																																																																																																																																																																																																										
140	-	-	-	-	79,0	-	59,2																																																																																																																																																																																																																																																																																																																																										
142	-	-	-	-	-	-	55,0																																																																																																																																																																																																																																																																																																																																										
144	-	-	-	-	-	53,0	51,0																																																																																																																																																																																																																																																																																																																																										
146	-	-	-	-	-	51,5	47,1																																																																																																																																																																																																																																																																																																																																										
150	-	-	-	-	-	48,8	41,1																																																																																																																																																																																																																																																																																																																																										
154	-	-	-	-	-	-	37,1																																																																																																																																																																																																																																																																																																																																										
158	-	-	-	-	-	-	29,2																																																																																																																																																																																																																																																																																																																																										

6 m steps of luffing jib is standard · 6 m Stufung der Wippe ist Standard · Des paliers de 6 m sont de série pour la fléchette

Main boom angle 88°, 85°, 75°, 65°, 55° and 45°; capacities for intermediate boom positions are calculated by the crane control system IC-1  
 Hauptauslegerwinkel 88°, 85°, 75°, 65°, 55° und 45°; Traglasten für Zwischenstellungen des Hauptauslegers werden von der Kransteuerung IC-1 berechnet

Jarret de flèche principale 88°, 85°, 75°, 65°, 55° et 45° ; le système de commande de la grue IC-1 calcule les charges pour les positions intermédiaires de la flèche

\* Main boom angle 88° · Hauptauslegerwinkel 88° · Jarret de flèche principale 88°



295 t + 60 t ZB		19-30 m		10,5 m		9.8 m/s		360°		ISO																																																																																																																																																																																																																																																																																																																																																																																																																																																																																																																																						
78 m + 108 m						84 m + 36 m																																																																																																																																																																																																																																																																																																																																																																																																																																																																																																																																										
<table border="1"> <thead> <tr> <th colspan="11">SWSL</th> <th>SFSL</th> </tr> <tr> <th colspan="2">0 t</th> <th colspan="9">0 t - 640 t</th> <th colspan="1"></th> </tr> <tr> <th colspan="2"></th> <th>85°</th> <th>85°</th> <th>75°</th> <th>65°</th> <th>55°</th> <th>45°</th> <th colspan="4"></th> <th></th> </tr> <tr> <th>m</th> <th>t</th> <th>t</th> <th>t</th> <th>t</th> <th>t</th> <th>t</th> <th>t</th> <th>t</th> <th>t</th> <th>t</th> <th>t</th> </tr> </thead> <tbody> <tr><td>40</td><td>-</td><td>126,0*</td><td>-</td><td>-</td><td>-</td><td>-</td><td>-</td><td>-</td><td>-</td><td>-</td><td>-</td></tr> <tr><td>42</td><td>-</td><td>125,0*</td><td>-</td><td>-</td><td>-</td><td>-</td><td>-</td><td>-</td><td>-</td><td>-</td><td>-</td></tr> <tr><td>46</td><td>-</td><td>123,0*</td><td>-</td><td>-</td><td>-</td><td>-</td><td>-</td><td>-</td><td>-</td><td>-</td><td>-</td></tr> <tr><td>50</td><td>64,5</td><td>127,0</td><td>-</td><td>-</td><td>-</td><td>-</td><td>-</td><td>-</td><td>-</td><td>127,0</td><td>-</td></tr> <tr><td>54</td><td>56,5</td><td>126,0</td><td>-</td><td>-</td><td>-</td><td>-</td><td>-</td><td>-</td><td>-</td><td>127,0</td><td>-</td></tr> <tr><td>58</td><td>49,6</td><td>125,0</td><td>-</td><td>-</td><td>-</td><td>-</td><td>-</td><td>-</td><td>-</td><td>126,0</td><td>-</td></tr> <tr><td>62</td><td>43,4</td><td>123,0</td><td>-</td><td>-</td><td>-</td><td>-</td><td>-</td><td>-</td><td>-</td><td>126,0</td><td>-</td></tr> <tr><td>66</td><td>37,8</td><td>121,0</td><td>-</td><td>-</td><td>-</td><td>-</td><td>-</td><td>-</td><td>-</td><td>125,0</td><td>-</td></tr> <tr><td>70</td><td>32,8</td><td>119,0</td><td>-</td><td>-</td><td>-</td><td>-</td><td>-</td><td>-</td><td>-</td><td>124,0</td><td>-</td></tr> <tr><td>74</td><td>28,3</td><td>117,0</td><td>-</td><td>-</td><td>-</td><td>-</td><td>-</td><td>-</td><td>-</td><td>123,0</td><td>-</td></tr> <tr><td>78</td><td>24,1</td><td>115,0</td><td>-</td><td>-</td><td>-</td><td>-</td><td>-</td><td>-</td><td>-</td><td>121,0</td><td>-</td></tr> <tr><td>80</td><td>22,2</td><td>115,0</td><td>119,0</td><td>-</td><td>-</td><td>-</td><td>-</td><td>-</td><td>-</td><td>120,0</td><td>-</td></tr> <tr><td>82</td><td>20,4</td><td>114,0</td><td>119,0</td><td>-</td><td>-</td><td>-</td><td>-</td><td>-</td><td>-</td><td>119,0</td><td>-</td></tr> <tr><td>86</td><td>16,9</td><td>111,5</td><td>119,0</td><td>-</td><td>-</td><td>-</td><td>-</td><td>-</td><td>-</td><td>117,0</td><td>-</td></tr> <tr><td>90</td><td>13,8</td><td>106,5</td><td>119,0</td><td>-</td><td>-</td><td>-</td><td>-</td><td>-</td><td>-</td><td>115,0</td><td>-</td></tr> <tr><td>92</td><td>12,3</td><td>103,0</td><td>119,0</td><td>-</td><td>-</td><td>-</td><td>-</td><td>-</td><td>-</td><td>113,5</td><td>-</td></tr> <tr><td>94</td><td>-</td><td>99,7</td><td>119,0</td><td>-</td><td>-</td><td>-</td><td>-</td><td>-</td><td>-</td><td>112,0</td><td>-</td></tr> <tr><td>98</td><td>-</td><td>93,2</td><td>118,0</td><td>-</td><td>-</td><td>-</td><td>-</td><td>-</td><td>-</td><td>110,0</td><td>-</td></tr> <tr><td>102</td><td>-</td><td>86,5</td><td>118,0</td><td>-</td><td>-</td><td>-</td><td>-</td><td>-</td><td>-</td><td>108,0</td><td>-</td></tr> <tr><td>106</td><td>-</td><td>78,5</td><td>109,0</td><td>-</td><td>-</td><td>-</td><td>-</td><td>-</td><td>-</td><td>106,0</td><td>-</td></tr> <tr><td>108</td><td>-</td><td>74,0</td><td>105,0</td><td>104,0</td><td>-</td><td>-</td><td>-</td><td>-</td><td>-</td><td>105,0</td><td>-</td></tr> <tr><td>110</td><td>-</td><td>69,0</td><td>101,0</td><td>104,0</td><td>-</td><td>-</td><td>-</td><td>-</td><td>-</td><td>104,0</td><td>-</td></tr> <tr><td>112</td><td>-</td><td>64,0</td><td>97,5</td><td>104,0</td><td>-</td><td>-</td><td>-</td><td>-</td><td>-</td><td>102,5</td><td>-</td></tr> <tr><td>114</td><td>-</td><td>-</td><td>93,5</td><td>104,0</td><td>-</td><td>-</td><td>-</td><td>-</td><td>-</td><td>101,0</td><td>-</td></tr> <tr><td>118</td><td>-</td><td>-</td><td>86,5</td><td>104,0</td><td>-</td><td>-</td><td>-</td><td>-</td><td>-</td><td>99,5</td><td>-</td></tr> <tr><td>122</td><td>-</td><td>-</td><td>80,0</td><td>103,0</td><td>-</td><td>-</td><td>-</td><td>-</td><td>-</td><td>97,5</td><td>-</td></tr> <tr><td>126</td><td>-</td><td>-</td><td>70,5</td><td>95,5</td><td>-</td><td>-</td><td>-</td><td>-</td><td>-</td><td>90,5</td><td>-</td></tr> <tr><td>130</td><td>-</td><td>-</td><td>-</td><td>88,5</td><td>-</td><td>-</td><td>-</td><td>-</td><td>-</td><td>83,5</td><td>-</td></tr> <tr><td>134</td><td>-</td><td>-</td><td>-</td><td>81,5</td><td>78,0</td><td>-</td><td>-</td><td>-</td><td>-</td><td>76,0</td><td>-</td></tr> <tr><td>138</td><td>-</td><td>-</td><td>-</td><td>76,0</td><td>73,5</td><td>-</td><td>-</td><td>-</td><td>-</td><td>67,5</td><td>-</td></tr> <tr><td>142</td><td>-</td><td>-</td><td>-</td><td>-</td><td>69,5</td><td>-</td><td>-</td><td>-</td><td>-</td><td>59,5</td><td>-</td></tr> <tr><td>146</td><td>-</td><td>-</td><td>-</td><td>-</td><td>66,0</td><td>-</td><td>-</td><td>-</td><td>-</td><td>51,5</td><td>-</td></tr> <tr><td>150</td><td>-</td><td>-</td><td>-</td><td>-</td><td>62,5</td><td>-</td><td>-</td><td>-</td><td>-</td><td>44,2</td><td>-</td></tr> <tr><td>154</td><td>-</td><td>-</td><td>-</td><td>-</td><td>-</td><td>-</td><td>-</td><td>-</td><td>38,5</td><td>36,9</td><td>-</td></tr> <tr><td>158</td><td>-</td><td>-</td><td>-</td><td>-</td><td>-</td><td>-</td><td>-</td><td>-</td><td>35,9</td><td>31,6</td><td>-</td></tr> <tr><td>160</td><td>-</td><td>-</td><td>-</td><td>-</td><td>-</td><td>-</td><td>-</td><td>-</td><td>34,7</td><td>29,5</td><td>-</td></tr> <tr><td>162</td><td>-</td><td>-</td><td>-</td><td>-</td><td>-</td><td>-</td><td>-</td><td>-</td><td>-</td><td>27,5</td><td>-</td></tr> <tr><td>166</td><td>-</td><td>-</td><td>-</td><td>-</td><td>-</td><td>-</td><td>-</td><td>-</td><td>-</td><td>21,5</td><td>-</td></tr> <tr><td>170</td><td>-</td><td>-</td><td>-</td><td>-</td><td>-</td><td>-</td><td>-</td><td>-</td><td>-</td><td>14,5</td><td>-</td></tr> </tbody> </table>												SWSL											SFSL	0 t		0 t - 640 t												85°	85°	75°	65°	55°	45°						m	t	t	t	t	t	t	t	t	t	t	t	40	-	126,0*	-	-	-	-	-	-	-	-	-	42	-	125,0*	-	-	-	-	-	-	-	-	-	46	-	123,0*	-	-	-	-	-	-	-	-	-	50	64,5	127,0	-	-	-	-	-	-	-	127,0	-	54	56,5	126,0	-	-	-	-	-	-	-	127,0	-	58	49,6	125,0	-	-	-	-	-	-	-	126,0	-	62	43,4	123,0	-	-	-	-	-	-	-	126,0	-	66	37,8	121,0	-	-	-	-	-	-	-	125,0	-	70	32,8	119,0	-	-	-	-	-	-	-	124,0	-	74	28,3	117,0	-	-	-	-	-	-	-	123,0	-	78	24,1	115,0	-	-	-	-	-	-	-	121,0	-	80	22,2	115,0	119,0	-	-	-	-	-	-	120,0	-	82	20,4	114,0	119,0	-	-	-	-	-	-	119,0	-	86	16,9	111,5	119,0	-	-	-	-	-	-	117,0	-	90	13,8	106,5	119,0	-	-	-	-	-	-	115,0	-	92	12,3	103,0	119,0	-	-	-	-	-	-	113,5	-	94	-	99,7	119,0	-	-	-	-	-	-	112,0	-	98	-	93,2	118,0	-	-	-	-	-	-	110,0	-	102	-	86,5	118,0	-	-	-	-	-	-	108,0	-	106	-	78,5	109,0	-	-	-	-	-	-	106,0	-	108	-	74,0	105,0	104,0	-	-	-	-	-	105,0	-	110	-	69,0	101,0	104,0	-	-	-	-	-	104,0	-	112	-	64,0	97,5	104,0	-	-	-	-	-	102,5	-	114	-	-	93,5	104,0	-	-	-	-	-	101,0	-	118	-	-	86,5	104,0	-	-	-	-	-	99,5	-	122	-	-	80,0	103,0	-	-	-	-	-	97,5	-	126	-	-	70,5	95,5	-	-	-	-	-	90,5	-	130	-	-	-	88,5	-	-	-	-	-	83,5	-	134	-	-	-	81,5	78,0	-	-	-	-	76,0	-	138	-	-	-	76,0	73,5	-	-	-	-	67,5	-	142	-	-	-	-	69,5	-	-	-	-	59,5	-	146	-	-	-	-	66,0	-	-	-	-	51,5	-	150	-	-	-	-	62,5	-	-	-	-	44,2	-	154	-	-	-	-	-	-	-	-	38,5	36,9	-	158	-	-	-	-	-	-	-	-	35,9	31,6	-	160	-	-	-	-	-	-	-	-	34,7	29,5	-	162	-	-	-	-	-	-	-	-	-	27,5	-	166	-	-	-	-	-	-	-	-	-	21,5	-	170	-	-	-	-	-	-	-	-	-	14,5	-
SWSL											SFSL																																																																																																																																																																																																																																																																																																																																																																																																																																																																																																																																					
0 t		0 t - 640 t																																																																																																																																																																																																																																																																																																																																																																																																																																																																																																																																														
		85°	85°	75°	65°	55°	45°																																																																																																																																																																																																																																																																																																																																																																																																																																																																																																																																									
m	t	t	t	t	t	t	t	t	t	t	t																																																																																																																																																																																																																																																																																																																																																																																																																																																																																																																																					
40	-	126,0*	-	-	-	-	-	-	-	-	-																																																																																																																																																																																																																																																																																																																																																																																																																																																																																																																																					
42	-	125,0*	-	-	-	-	-	-	-	-	-																																																																																																																																																																																																																																																																																																																																																																																																																																																																																																																																					
46	-	123,0*	-	-	-	-	-	-	-	-	-																																																																																																																																																																																																																																																																																																																																																																																																																																																																																																																																					
50	64,5	127,0	-	-	-	-	-	-	-	127,0	-																																																																																																																																																																																																																																																																																																																																																																																																																																																																																																																																					
54	56,5	126,0	-	-	-	-	-	-	-	127,0	-																																																																																																																																																																																																																																																																																																																																																																																																																																																																																																																																					
58	49,6	125,0	-	-	-	-	-	-	-	126,0	-																																																																																																																																																																																																																																																																																																																																																																																																																																																																																																																																					
62	43,4	123,0	-	-	-	-	-	-	-	126,0	-																																																																																																																																																																																																																																																																																																																																																																																																																																																																																																																																					
66	37,8	121,0	-	-	-	-	-	-	-	125,0	-																																																																																																																																																																																																																																																																																																																																																																																																																																																																																																																																					
70	32,8	119,0	-	-	-	-	-	-	-	124,0	-																																																																																																																																																																																																																																																																																																																																																																																																																																																																																																																																					
74	28,3	117,0	-	-	-	-	-	-	-	123,0	-																																																																																																																																																																																																																																																																																																																																																																																																																																																																																																																																					
78	24,1	115,0	-	-	-	-	-	-	-	121,0	-																																																																																																																																																																																																																																																																																																																																																																																																																																																																																																																																					
80	22,2	115,0	119,0	-	-	-	-	-	-	120,0	-																																																																																																																																																																																																																																																																																																																																																																																																																																																																																																																																					
82	20,4	114,0	119,0	-	-	-	-	-	-	119,0	-																																																																																																																																																																																																																																																																																																																																																																																																																																																																																																																																					
86	16,9	111,5	119,0	-	-	-	-	-	-	117,0	-																																																																																																																																																																																																																																																																																																																																																																																																																																																																																																																																					
90	13,8	106,5	119,0	-	-	-	-	-	-	115,0	-																																																																																																																																																																																																																																																																																																																																																																																																																																																																																																																																					
92	12,3	103,0	119,0	-	-	-	-	-	-	113,5	-																																																																																																																																																																																																																																																																																																																																																																																																																																																																																																																																					
94	-	99,7	119,0	-	-	-	-	-	-	112,0	-																																																																																																																																																																																																																																																																																																																																																																																																																																																																																																																																					
98	-	93,2	118,0	-	-	-	-	-	-	110,0	-																																																																																																																																																																																																																																																																																																																																																																																																																																																																																																																																					
102	-	86,5	118,0	-	-	-	-	-	-	108,0	-																																																																																																																																																																																																																																																																																																																																																																																																																																																																																																																																					
106	-	78,5	109,0	-	-	-	-	-	-	106,0	-																																																																																																																																																																																																																																																																																																																																																																																																																																																																																																																																					
108	-	74,0	105,0	104,0	-	-	-	-	-	105,0	-																																																																																																																																																																																																																																																																																																																																																																																																																																																																																																																																					
110	-	69,0	101,0	104,0	-	-	-	-	-	104,0	-																																																																																																																																																																																																																																																																																																																																																																																																																																																																																																																																					
112	-	64,0	97,5	104,0	-	-	-	-	-	102,5	-																																																																																																																																																																																																																																																																																																																																																																																																																																																																																																																																					
114	-	-	93,5	104,0	-	-	-	-	-	101,0	-																																																																																																																																																																																																																																																																																																																																																																																																																																																																																																																																					
118	-	-	86,5	104,0	-	-	-	-	-	99,5	-																																																																																																																																																																																																																																																																																																																																																																																																																																																																																																																																					
122	-	-	80,0	103,0	-	-	-	-	-	97,5	-																																																																																																																																																																																																																																																																																																																																																																																																																																																																																																																																					
126	-	-	70,5	95,5	-	-	-	-	-	90,5	-																																																																																																																																																																																																																																																																																																																																																																																																																																																																																																																																					
130	-	-	-	88,5	-	-	-	-	-	83,5	-																																																																																																																																																																																																																																																																																																																																																																																																																																																																																																																																					
134	-	-	-	81,5	78,0	-	-	-	-	76,0	-																																																																																																																																																																																																																																																																																																																																																																																																																																																																																																																																					
138	-	-	-	76,0	73,5	-	-	-	-	67,5	-																																																																																																																																																																																																																																																																																																																																																																																																																																																																																																																																					
142	-	-	-	-	69,5	-	-	-	-	59,5	-																																																																																																																																																																																																																																																																																																																																																																																																																																																																																																																																					
146	-	-	-	-	66,0	-	-	-	-	51,5	-																																																																																																																																																																																																																																																																																																																																																																																																																																																																																																																																					
150	-	-	-	-	62,5	-	-	-	-	44,2	-																																																																																																																																																																																																																																																																																																																																																																																																																																																																																																																																					
154	-	-	-	-	-	-	-	-	38,5	36,9	-																																																																																																																																																																																																																																																																																																																																																																																																																																																																																																																																					
158	-	-	-	-	-	-	-	-	35,9	31,6	-																																																																																																																																																																																																																																																																																																																																																																																																																																																																																																																																					
160	-	-	-	-	-	-	-	-	34,7	29,5	-																																																																																																																																																																																																																																																																																																																																																																																																																																																																																																																																					
162	-	-	-	-	-	-	-	-	-	27,5	-																																																																																																																																																																																																																																																																																																																																																																																																																																																																																																																																					
166	-	-	-	-	-	-	-	-	-	21,5	-																																																																																																																																																																																																																																																																																																																																																																																																																																																																																																																																					
170	-	-	-	-	-	-	-	-	-	14,5	-																																																																																																																																																																																																																																																																																																																																																																																																																																																																																																																																					
<table border="1"> <thead> <tr> <th colspan="11">SWSL</th> <th>SFSL</th> </tr> <tr> <th colspan="2">0 t</th> <th colspan="9">0 t - 640 t</th> <th colspan="1"></th> </tr> <tr> <th colspan="2"></th> <th>85°</th> <th>85°</th> <th>75°</th> <th>65°</th> <th>55°</th> <th>45°</th> <th colspan="4"></th> <th></th> </tr> <tr> <th>m</th> <th>t</th> <th>t</th> <th>t</th> <th>t</th> <th>t</th> <th>t</th> <th>t</th> <th>t</th> <th>t</th> <th>t</th> <th>t</th> </tr> </thead> <tbody> <tr><td>20</td><td>-</td><td>411,0*</td><td>-</td><td>-</td><td>-</td><td>-</td><td>-</td><td>-</td><td>-</td><td>-</td><td>-</td></tr> <tr><td>22</td><td>-</td><td>399,0*</td><td>-</td><td>-</td><td>-</td><td>-</td><td>-</td><td>-</td><td>-</td><td>-</td><td>-</td></tr> <tr><td>24</td><td>-</td><td>386,0*</td><td>-</td><td>-</td><td>-</td><td>-</td><td>-</td><td>-</td><td>-</td><td>-</td><td>-</td></tr> <tr><td>26</td><td>221,0</td><td>430,0</td><td>-</td><td>-</td><td>-</td><td>-</td><td>-</td><td>-</td><td>-</td><td>419,0</td><td>-</td></tr> <tr><td>28</td><td>205,0</td><td>421,0</td><td>-</td><td>-</td><td>-</td><td>-</td><td>-</td><td>-</td><td>-</td><td>419,0</td><td>-</td></tr> <tr><td>30</td><td>192,0</td><td>412,0</td><td>-</td><td>-</td><td>-</td><td>-</td><td>-</td><td>-</td><td>-</td><td>419,0</td><td>-</td></tr> <tr><td>34</td><td>168,0</td><td>392,0</td><td>-</td><td>-</td><td>-</td><td>-</td><td>-</td><td>-</td><td>-</td><td>419,0</td><td>-</td></tr> <tr><td>38</td><td>150,0</td><td>374,0</td><td>-</td><td>-</td><td>-</td><td>-</td><td>-</td><td>-</td><td>-</td><td>419,0</td><td>-</td></tr> <tr><td>42</td><td>134,0</td><td>358,0</td><td>-</td><td>-</td><td>-</td><td>-</td><td>-</td><td>-</td><td>-</td><td>417,0</td><td>-</td></tr> <tr><td>44</td><td>126,0</td><td>334,0</td><td>-</td><td>-</td><td>-</td><td>-</td><td>-</td><td>-</td><td>-</td><td>409,0</td><td>-</td></tr> <tr><td>45</td><td>-</td><td>-</td><td>430,0</td><td>-</td><td>-</td><td>-</td><td>-</td><td>-</td><td>-</td><td>402,5</td><td>-</td></tr> <tr><td>46</td><td>-</td><td>-</td><td>430,0</td><td>-</td><td>-</td><td>-</td><td>-</td><td>-</td><td>-</td><td>397,0</td><td>-</td></tr> <tr><td>50</td><td>-</td><td>-</td><td>417,0</td><td>-</td><td>-</td><td>-</td><td>-</td><td>-</td><td>-</td><td>380,0</td><td>-</td></tr> <tr><td>54</td><td>-</td><td>-</td><td>385,0</td><td>-</td><td>-</td><td>-</td><td>-</td><td>-</td><td>-</td><td>365,0</td><td>-</td></tr> <tr><td>58</td><td>-</td><td>-</td><td>340,0</td><td>-</td><td>-</td><td>-</td><td>-</td><td>-</td><td>-</td><td>332,0</td><td>-</td></tr> <tr><td>62</td><td>-</td><td>-</td><td>-</td><td>-</td><td>-</td><td>-</td><td>-</td><td>-</td><td>-</td><td>302,0</td><td>-</td></tr> <tr><td>64</td><td>-</td><td>-</td><td>-</td><td>291,0</td><td>-</td><td>-</td><td>-</td><td>-</td><td>-</td><td>288,5</td><td>-</td></tr> <tr><td>66</td><td>-</td><td>-</td><td>-</td><td>281,0</td><td>-</td><td>-</td><td>-</td><td>-</td><td>-</td><td>275,0</td><td>-</td></tr> <tr><td>70</td><td>-</td><td>-</td><td>-</td><td>262,0</td><td>-</td><td>-</td><td>-</td><td>-</td><td>-</td><td>252,0</td><td>-</td></tr> <tr><td>73</td><td>-</td><td>-</td><td>-</td><td>250,0</td><td>-</td><td>-</td><td>-</td><td>-</td><td>-</td><td>236,2</td><td>-</td></tr> <tr><td>74</td><td>-</td><td>-</td><td>-</td><td>-</td><td>-</td><td>-</td><td>-</td><td>-</td><td>-</td><td>231,0</td><td>-</td></tr> <tr><td>78</td><td>-</td><td>-</td><td>-</td><td>-</td><td>-</td><td>-</td><td>-</td><td>-</td><td>-</td><td>213,0</td><td>-</td></tr> <tr><td>81</td><td>-</td><td>-</td><td>-</td><td>-</td><td>-</td><td>202,0</td><td>-</td><td>-</td><td>-</td><td>200,2</td><td>-</td></tr> <tr><td>82</td><td>-</td><td>-</td><td>-</td><td>-</td><td>-</td><td>199,0</td><td>-</td><td>-</td><td>-</td><td>196,0</td><td>-</td></tr> <tr><td>86</td><td>-</td><td>-</td><td>-</td><td>-</td><td>-</td><td>188,0</td><td>-</td><td>-</td><td>-</td><td>181,0</td><td>-</td></tr> <tr><td>90</td><td>-</td><td>-</td><td>-</td><td>-</td><td>-</td><td>-</td><td>-</td><td>-</td><td>-</td><td>167,0</td><td>-</td></tr> <tr><td>94</td><td>-</td><td>-</td><td>-</td><td>-</td><td>-</td><td>-</td><td>-</td><td>-</td><td>-</td><td>150,0</td><td>-</td></tr> <tr><td>95</td><td>-</td><td>-</td><td>-</td><td>-</td><td>-</td><td>-</td><td>-</td><td>-</td><td>147,0</td><td>145,7</td><td>-</td></tr> <tr><td>97</td><td>-</td><td>-</td><td>-</td><td>-</td><td>-</td><td>-</td><td>-</td><td>-</td><td>143,0</td><td>137,2</td><td>-</td></tr> <tr><td>98</td><td>-</td><td>-</td><td>-</td><td>-</td><td>-</td><td>-</td><td>-</td><td>-</td><td>-</td><td>133,0</td><td>-</td></tr> <tr><td>102</td><td>-</td><td>-</td><td>-</td><td>-</td><td>-</td><td>-</td><td>-</td><td>-</td><td>-</td><td>116,0</td><td>-</td></tr> <tr><td>106</td><td>-</td><td>-</td><td>-</td><td>-</td><td>-</td><td>-</td><td>-</td><td>-</td><td>-</td><td>100,0</td><td>-</td></tr> </tbody> </table>												SWSL											SFSL	0 t		0 t - 640 t												85°	85°	75°	65°	55°	45°						m	t	t	t	t	t	t	t	t	t	t	t	20	-	411,0*	-	-	-	-	-	-	-	-	-	22	-	399,0*	-	-	-	-	-	-	-	-	-	24	-	386,0*	-	-	-	-	-	-	-	-	-	26	221,0	430,0	-	-	-	-	-	-	-	419,0	-	28	205,0	421,0	-	-	-	-	-	-	-	419,0	-	30	192,0	412,0	-	-	-	-	-	-	-	419,0	-	34	168,0	392,0	-	-	-	-	-	-	-	419,0	-	38	150,0	374,0	-	-	-	-	-	-	-	419,0	-	42	134,0	358,0	-	-	-	-	-	-	-	417,0	-	44	126,0	334,0	-	-	-	-	-	-	-	409,0	-	45	-	-	430,0	-	-	-	-	-	-	402,5	-	46	-	-	430,0	-	-	-	-	-	-	397,0	-	50	-	-	417,0	-	-	-	-	-	-	380,0	-	54	-	-	385,0	-	-	-	-	-	-	365,0	-	58	-	-	340,0	-	-	-	-	-	-	332,0	-	62	-	-	-	-	-	-	-	-	-	302,0	-	64	-	-	-	291,0	-	-	-	-	-	288,5	-	66	-	-	-	281,0	-	-	-	-	-	275,0	-	70	-	-	-	262,0	-	-	-	-	-	252,0	-	73	-	-	-	250,0	-	-	-	-	-	236,2	-	74	-	-	-	-	-	-	-	-	-	231,0	-	78	-	-	-	-	-	-	-	-	-	213,0	-	81	-	-	-	-	-	202,0	-	-	-	200,2	-	82	-	-	-	-	-	199,0	-	-	-	196,0	-	86	-	-	-	-	-	188,0	-	-	-	181,0	-	90	-	-	-	-	-	-	-	-	-	167,0	-	94	-	-	-	-	-	-	-	-	-	150,0	-	95	-	-	-	-	-	-	-	-	147,0	145,7	-	97	-	-	-	-	-	-	-	-	143,0	137,2	-	98	-	-	-	-	-	-	-	-	-	133,0	-	102	-	-	-	-	-	-	-	-	-	116,0	-	106	-	-	-	-	-	-	-	-	-	100,0	-																																																																																				
SWSL											SFSL																																																																																																																																																																																																																																																																																																																																																																																																																																																																																																																																					
0 t		0 t - 640 t																																																																																																																																																																																																																																																																																																																																																																																																																																																																																																																																														
		85°	85°	75°	65°	55°	45°																																																																																																																																																																																																																																																																																																																																																																																																																																																																																																																																									
m	t	t	t	t	t	t	t	t	t	t	t																																																																																																																																																																																																																																																																																																																																																																																																																																																																																																																																					
20	-	411,0*	-	-	-	-	-	-	-	-	-																																																																																																																																																																																																																																																																																																																																																																																																																																																																																																																																					
22	-	399,0*	-	-	-	-	-	-	-	-	-																																																																																																																																																																																																																																																																																																																																																																																																																																																																																																																																					
24	-	386,0*	-	-	-	-	-	-	-	-	-																																																																																																																																																																																																																																																																																																																																																																																																																																																																																																																																					
26	221,0	430,0	-	-	-	-	-	-	-	419,0	-																																																																																																																																																																																																																																																																																																																																																																																																																																																																																																																																					
28	205,0	421,0	-	-	-	-	-	-	-	419,0	-																																																																																																																																																																																																																																																																																																																																																																																																																																																																																																																																					
30	192,0	412,0	-	-	-	-	-	-	-	419,0	-																																																																																																																																																																																																																																																																																																																																																																																																																																																																																																																																					
34	168,0	392,0	-	-	-	-	-	-	-	419,0	-																																																																																																																																																																																																																																																																																																																																																																																																																																																																																																																																					
38	150,0	374,0	-	-	-	-	-	-	-	419,0	-																																																																																																																																																																																																																																																																																																																																																																																																																																																																																																																																					
42	134,0	358,0	-	-	-	-	-	-	-	417,0	-																																																																																																																																																																																																																																																																																																																																																																																																																																																																																																																																					
44	126,0	334,0	-	-	-	-	-	-	-	409,0	-																																																																																																																																																																																																																																																																																																																																																																																																																																																																																																																																					
45	-	-	430,0	-	-	-	-	-	-	402,5	-																																																																																																																																																																																																																																																																																																																																																																																																																																																																																																																																					
46	-	-	430,0	-	-	-	-	-	-	397,0	-																																																																																																																																																																																																																																																																																																																																																																																																																																																																																																																																					
50	-	-	417,0	-	-	-	-	-	-	380,0	-																																																																																																																																																																																																																																																																																																																																																																																																																																																																																																																																					
54	-	-	385,0	-	-	-	-	-	-	365,0	-																																																																																																																																																																																																																																																																																																																																																																																																																																																																																																																																					
58	-	-	340,0	-	-	-	-	-	-	332,0	-																																																																																																																																																																																																																																																																																																																																																																																																																																																																																																																																					
62	-	-	-	-	-	-	-	-	-	302,0	-																																																																																																																																																																																																																																																																																																																																																																																																																																																																																																																																					
64	-	-	-	291,0	-	-	-	-	-	288,5	-																																																																																																																																																																																																																																																																																																																																																																																																																																																																																																																																					
66	-	-	-	281,0	-	-	-	-	-	275,0	-																																																																																																																																																																																																																																																																																																																																																																																																																																																																																																																																					
70	-	-	-	262,0	-	-	-	-	-	252,0	-																																																																																																																																																																																																																																																																																																																																																																																																																																																																																																																																					
73	-	-	-	250,0	-	-	-	-	-	236,2	-																																																																																																																																																																																																																																																																																																																																																																																																																																																																																																																																					
74	-	-	-	-	-	-	-	-	-	231,0	-																																																																																																																																																																																																																																																																																																																																																																																																																																																																																																																																					
78	-	-	-	-	-	-	-	-	-	213,0	-																																																																																																																																																																																																																																																																																																																																																																																																																																																																																																																																					
81	-	-	-	-	-	202,0	-	-	-	200,2	-																																																																																																																																																																																																																																																																																																																																																																																																																																																																																																																																					
82	-	-	-	-	-	199,0	-	-	-	196,0	-																																																																																																																																																																																																																																																																																																																																																																																																																																																																																																																																					
86	-	-	-	-	-	188,0	-	-	-	181,0	-																																																																																																																																																																																																																																																																																																																																																																																																																																																																																																																																					
90	-	-	-	-	-	-	-	-	-	167,0	-																																																																																																																																																																																																																																																																																																																																																																																																																																																																																																																																					
94	-	-	-	-	-	-	-	-	-	150,0	-																																																																																																																																																																																																																																																																																																																																																																																																																																																																																																																																					
95	-	-	-	-	-	-	-	-	147,0	145,7	-																																																																																																																																																																																																																																																																																																																																																																																																																																																																																																																																					
97	-	-	-	-	-	-	-	-	143,0	137,2	-																																																																																																																																																																																																																																																																																																																																																																																																																																																																																																																																					
98	-	-	-	-	-	-	-	-	-	133,0	-																																																																																																																																																																																																																																																																																																																																																																																																																																																																																																																																					
102	-	-	-	-	-	-	-	-	-	116,0	-																																																																																																																																																																																																																																																																																																																																																																																																																																																																																																																																					
106	-	-	-	-	-	-	-	-	-	100,0	-																																																																																																																																																																																																																																																																																																																																																																																																																																																																																																																																					

6 m steps of luffing jib is standard · 6 m Stufung der Wippe ist Standard · Des paliers de 6 m sont de série pour la fléchette

Main boom angle 88°, 85°, 75°, 65°, 55° and 45°; capacities for intermediate boom positions are calculated by the crane control system IC-1  
 Hauptauslegerwinkel 88°, 85°, 75°, 65°, 55° und 45°; Traglasten für Zwischenstellungen des Hauptauslegers werden von der Kransteuerung IC-1 berechnet

Jarret de flèche principale 88°, 85°, 75°, 65°, 55° et 45° ; le système de commande de la grue IC-1 calcule les charges pour les positions intermédiaires de la flèche

\* Main boom angle 88° · Hauptauslegerwinkel 88° · Jarret de flèche principale 88°

295 t + 60 t ZB		19-30 m		10,5 m		9.8 m/s		360°		ISO	
84 m + 48 m						84 m + 60 m					
		SWSL						SFSL			
		0 t		0 t - 640 t							
		85°		85°		75°		65°		45°	
		m		t		t		t		t	
24	-	330,0*	-	-	-	-	-	-	-	-	-
26	-	322,0*	-	-	-	-	-	-	-	-	-
28	-	314,0*	-	-	-	-	-	-	-	-	-
30	178,0	347,0	-	-	-	-	-	-	-	337,0	-
34	156,0	335,0	-	-	-	-	-	-	-	337,0	-
38	139,0	323,0	-	-	-	-	-	-	-	337,0	-
42	124,0	310,0	-	-	-	-	-	-	-	337,0	-
46	111,0	298,0	-	-	-	-	-	-	-	337,0	-
50	101,0	288,0	-	-	-	-	-	-	-	329,0	-
52	95,5	279,0	353,0	-	-	-	-	-	-	323,5	-
54	90,0	263,0	352,0	-	-	-	-	-	-	318,0	-
56	85,0	247,0	348,0	-	-	-	-	-	-	309,0	-
58	-	-	342,0	-	-	-	-	-	-	304,0	-
62	-	-	320,0	-	-	-	-	-	-	293,0	-
66	-	-	283,0	-	-	-	-	-	-	279,0	-
70	-	-	253,0	-	-	-	-	-	-	255,0	-
72	-	-	-	248,0	-	-	-	-	-	244,5	-
74	-	-	-	240,0	-	-	-	-	-	234,0	-
78	-	-	-	225,0	-	-	-	-	-	215,0	-
82	-	-	-	212,0	-	-	-	-	-	199,0	-
84	-	-	-	206,0	-	-	-	-	-	191,0	-
86	-	-	-	-	-	-	-	-	-	183,0	-
90	-	-	-	-	171,0	-	-	-	-	169,0	-
94	-	-	-	-	162,0	-	-	-	-	157,0	-
97	-	-	-	-	156,0	-	-	-	-	148,0	-
98	-	-	-	-	-	-	-	-	-	145,0	-
102	-	-	-	-	-	-	-	-	-	131,0	-
106	-	-	-	-	-	-	-	119,0	117,0	-	-
109	-	-	-	-	-	-	-	115,0	106,5	-	-
110	-	-	-	-	-	-	-	-	103,0	-	-
114	-	-	-	-	-	-	-	-	89,5	-	-
118	-	-	-	-	-	-	-	-	77,5	-	-
26	-	270,0*	-	-	-	-	-	-	-	-	-
28	-	268,0*	-	-	-	-	-	-	-	-	-
30	-	263,0*	-	-	-	-	-	-	-	-	-
34	146,0	281,0	-	-	-	-	-	-	-	275,0	-
38	129,0	275,0	-	-	-	-	-	-	-	275,0	-
42	115,0	267,0	-	-	-	-	-	-	-	275,0	-
46	103,0	259,0	-	-	-	-	-	-	-	275,0	-
50	93,0	251,0	-	-	-	-	-	-	-	275,0	-
54	84,0	243,0	-	-	-	-	-	-	-	271,0	-
58	76,5	234,0	289,0	-	-	-	-	-	-	264,0	-
62	69,5	225,0	284,0	-	-	-	-	-	-	256,0	-
66	63,5	199,0	279,0	-	-	-	-	-	-	246,0	-
68	60,0	182,0	275,0	-	-	-	-	-	-	242,5	-
70	-	-	266,0	-	-	-	-	-	-	239,0	-
74	-	-	239,0	-	-	-	-	-	-	232,0	-
78	-	-	217,0	-	-	-	-	-	-	221,0	-
79	-	-	212,0	219,0	-	-	-	-	-	216,7	-
82	-	-	198,0	209,0	-	-	-	-	-	204,0	-
86	-	-	-	197,0	-	-	-	-	-	189,0	-
90	-	-	-	187,0	-	-	-	-	-	175,0	-
94	-	-	-	177,0	-	-	-	-	-	162,0	-
96	-	-	-	172,0	-	-	-	-	-	156,0	-
98	-	-	-	-	-	-	-	-	-	150,0	-
99	-	-	-	-	-	148,0	-	-	-	147,2	-
102	-	-	-	-	-	143,0	-	-	-	139,0	-
106	-	-	-	-	-	136,0	-	-	-	129,0	-
108	-	-	-	-	-	133,0	-	-	-	123,5	-
110	-	-	-	-	-	-	-	-	-	118,0	-
114	-	-	-	-	-	-	-	-	-	105,0	-
116	-	-	-	-	-	-	-	-	101,0	99,2	-
118	-	-	-	-	-	-	-	-	98,0	93,5	-
120	-	-	-	-	-	-	-	-	95,5	87,5	-
122	-	-	-	-	-	-	-	-	-	81,5	-
126	-	-	-	-	-	-	-	-	-	70,0	-
130	-	-	-	-	-	-	-	-	-	62,0	-

6 m steps of luffing jib is standard · 6 m Stufung der Wippe ist Standard · Des paliers de 6 m sont de série pour la fléchette

Main boom angle 88°, 85°, 75°, 65°, 55° and 45°; capacities for intermediate boom positions are calculated by the crane control system IC-1  
Hauptauslegerwinkel 88°, 85°, 75°, 65°, 55° und 45°; Traglasten für Zwischenstellungen des Hauptauslegers werden von der Kransteuerung IC-1 berechnet

Jarret de flèche principale 88°, 85°, 75°, 65°, 55° et 45° ; le système de commande de la grue IC-1 calcule les charges pour les positions intermédiaires de la flèche

\* Main boom angle 88° · Hauptauslegerwinkel 88° · Jarret de flèche principale 88°

295 t + 60 t ZB		19-30 m		10,5 m		9.8 m/s		360°		ISO																																																																																																																																																																																																																																																																																																																																																																																																																																																																																					
84 m + 72 m						84 m + 84 m																																																																																																																																																																																																																																																																																																																																																																																																																																																																																									
<table border="1"> <thead> <tr> <th colspan="11">SWSL</th> <th>SFSL</th> </tr> <tr> <th colspan="11">0 t</th> <th>0 t - 640 t</th> </tr> <tr> <th colspan="11">85° 85° 75° 65° 55° 45°</th> <th></th> </tr> <tr> <th>m</th> <th>t</th> <th>t</th> <th>t</th> <th>t</th> <th>t</th> <th>t</th> <th>t</th> <th>t</th> <th>t</th> <th>t</th> <th>t</th> </tr> </thead> <tbody> <tr><td>30</td><td>-</td><td>220,0*</td><td>-</td><td>-</td><td>-</td><td>-</td><td>-</td><td>-</td><td>-</td><td>-</td><td>-</td></tr> <tr><td>34</td><td>-</td><td>215,0*</td><td>-</td><td>-</td><td>-</td><td>-</td><td>-</td><td>-</td><td>-</td><td>-</td><td>-</td></tr> <tr><td>38</td><td>120,0</td><td>230,0</td><td>-</td><td>-</td><td>-</td><td>-</td><td>-</td><td>-</td><td>-</td><td>224,0</td><td>-</td></tr> <tr><td>42</td><td>106,0</td><td>225,0</td><td>-</td><td>-</td><td>-</td><td>-</td><td>-</td><td>-</td><td>-</td><td>224,0</td><td>-</td></tr> <tr><td>46</td><td>95,0</td><td>220,0</td><td>-</td><td>-</td><td>-</td><td>-</td><td>-</td><td>-</td><td>-</td><td>224,0</td><td>-</td></tr> <tr><td>50</td><td>85,5</td><td>215,0</td><td>-</td><td>-</td><td>-</td><td>-</td><td>-</td><td>-</td><td>-</td><td>224,0</td><td>-</td></tr> <tr><td>54</td><td>76,5</td><td>209,0</td><td>-</td><td>-</td><td>-</td><td>-</td><td>-</td><td>-</td><td>-</td><td>224,0</td><td>-</td></tr> <tr><td>58</td><td>69,0</td><td>204,0</td><td>-</td><td>-</td><td>-</td><td>-</td><td>-</td><td>-</td><td>-</td><td>224,0</td><td>-</td></tr> <tr><td>62</td><td>62,5</td><td>199,0</td><td>-</td><td>-</td><td>-</td><td>-</td><td>-</td><td>-</td><td>-</td><td>219,0</td><td>-</td></tr> <tr><td>64</td><td>59,5</td><td>195,0</td><td>233,0</td><td>-</td><td>-</td><td>-</td><td>-</td><td>-</td><td>-</td><td>216,5</td><td>-</td></tr> <tr><td>66</td><td>56,5</td><td>192,0</td><td>233,0</td><td>-</td><td>-</td><td>-</td><td>-</td><td>-</td><td>-</td><td>214,0</td><td>-</td></tr> <tr><td>70</td><td>51,5</td><td>185,0</td><td>232,0</td><td>-</td><td>-</td><td>-</td><td>-</td><td>-</td><td>-</td><td>210,0</td><td>-</td></tr> <tr><td>74</td><td>46,7</td><td>169,0</td><td>226,0</td><td>-</td><td>-</td><td>-</td><td>-</td><td>-</td><td>-</td><td>205,0</td><td>-</td></tr> <tr><td>78</td><td>42,4</td><td>147,0</td><td>222,0</td><td>-</td><td>-</td><td>-</td><td>-</td><td>-</td><td>-</td><td>198,0</td><td>-</td></tr> <tr><td>82</td><td>-</td><td>-</td><td>202,0</td><td>-</td><td>-</td><td>-</td><td>-</td><td>-</td><td>-</td><td>193,0</td><td>-</td></tr> <tr><td>86</td><td>-</td><td>-</td><td>185,0</td><td>-</td><td>-</td><td>-</td><td>-</td><td>-</td><td>-</td><td>188,0</td><td>-</td></tr> <tr><td>88</td><td>-</td><td>-</td><td>177,0</td><td>187,0</td><td>-</td><td>-</td><td>-</td><td>-</td><td>-</td><td>182,5</td><td>-</td></tr> <tr><td>90</td><td>-</td><td>-</td><td>170,0</td><td>181,0</td><td>-</td><td>-</td><td>-</td><td>-</td><td>-</td><td>177,0</td><td>-</td></tr> <tr><td>94</td><td>-</td><td>-</td><td>150,0</td><td>172,0</td><td>-</td><td>-</td><td>-</td><td>-</td><td>-</td><td>164,0</td><td>-</td></tr> <tr><td>98</td><td>-</td><td>-</td><td>-</td><td>163,0</td><td>-</td><td>-</td><td>-</td><td>-</td><td>-</td><td>152,0</td><td>-</td></tr> <tr><td>102</td><td>-</td><td>-</td><td>-</td><td>154,0</td><td>-</td><td>-</td><td>-</td><td>-</td><td>-</td><td>141,0</td><td>-</td></tr> <tr><td>106</td><td>-</td><td>-</td><td>-</td><td>147,0</td><td>-</td><td>-</td><td>-</td><td>-</td><td>-</td><td>131,0</td><td>-</td></tr> <tr><td>108</td><td>-</td><td>-</td><td>-</td><td>-</td><td>127,0</td><td>-</td><td>-</td><td>-</td><td>-</td><td>126,0</td><td>-</td></tr> <tr><td>110</td><td>-</td><td>-</td><td>-</td><td>-</td><td>124,0</td><td>-</td><td>-</td><td>-</td><td>-</td><td>121,0</td><td>-</td></tr> <tr><td>114</td><td>-</td><td>-</td><td>-</td><td>-</td><td>118,0</td><td>-</td><td>-</td><td>-</td><td>-</td><td>112,0</td><td>-</td></tr> <tr><td>118</td><td>-</td><td>-</td><td>-</td><td>-</td><td>113,0</td><td>-</td><td>-</td><td>-</td><td>-</td><td>103,0</td><td>-</td></tr> <tr><td>120</td><td>-</td><td>-</td><td>-</td><td>-</td><td>110,0</td><td>-</td><td>-</td><td>-</td><td>-</td><td>97,7</td><td>-</td></tr> <tr><td>122</td><td>-</td><td>-</td><td>-</td><td>-</td><td>-</td><td>-</td><td>-</td><td>-</td><td>-</td><td>92,5</td><td>-</td></tr> <tr><td>126</td><td>-</td><td>-</td><td>-</td><td>-</td><td>-</td><td>-</td><td>-</td><td>-</td><td>-</td><td>81,5</td><td>-</td></tr> <tr><td>128</td><td>-</td><td>-</td><td>-</td><td>-</td><td>-</td><td>-</td><td>-</td><td>-</td><td>80,0</td><td>76,5</td><td>-</td></tr> <tr><td>130</td><td>-</td><td>-</td><td>-</td><td>-</td><td>-</td><td>-</td><td>-</td><td>-</td><td>78,0</td><td>71,5</td><td>-</td></tr> <tr><td>134</td><td>-</td><td>-</td><td>-</td><td>-</td><td>-</td><td>-</td><td>-</td><td>-</td><td>-</td><td>61,0</td><td>-</td></tr> <tr><td>138</td><td>-</td><td>-</td><td>-</td><td>-</td><td>-</td><td>-</td><td>-</td><td>-</td><td>-</td><td>52,0</td><td>-</td></tr> <tr><td>142</td><td>-</td><td>-</td><td>-</td><td>-</td><td>-</td><td>-</td><td>-</td><td>-</td><td>-</td><td>47,8</td><td>-</td></tr> </tbody> </table>												SWSL											SFSL	0 t											0 t - 640 t	85° 85° 75° 65° 55° 45°												m	t	t	t	t	t	t	t	t	t	t	t	30	-	220,0*	-	-	-	-	-	-	-	-	-	34	-	215,0*	-	-	-	-	-	-	-	-	-	38	120,0	230,0	-	-	-	-	-	-	-	224,0	-	42	106,0	225,0	-	-	-	-	-	-	-	224,0	-	46	95,0	220,0	-	-	-	-	-	-	-	224,0	-	50	85,5	215,0	-	-	-	-	-	-	-	224,0	-	54	76,5	209,0	-	-	-	-	-	-	-	224,0	-	58	69,0	204,0	-	-	-	-	-	-	-	224,0	-	62	62,5	199,0	-	-	-	-	-	-	-	219,0	-	64	59,5	195,0	233,0	-	-	-	-	-	-	216,5	-	66	56,5	192,0	233,0	-	-	-	-	-	-	214,0	-	70	51,5	185,0	232,0	-	-	-	-	-	-	210,0	-	74	46,7	169,0	226,0	-	-	-	-	-	-	205,0	-	78	42,4	147,0	222,0	-	-	-	-	-	-	198,0	-	82	-	-	202,0	-	-	-	-	-	-	193,0	-	86	-	-	185,0	-	-	-	-	-	-	188,0	-	88	-	-	177,0	187,0	-	-	-	-	-	182,5	-	90	-	-	170,0	181,0	-	-	-	-	-	177,0	-	94	-	-	150,0	172,0	-	-	-	-	-	164,0	-	98	-	-	-	163,0	-	-	-	-	-	152,0	-	102	-	-	-	154,0	-	-	-	-	-	141,0	-	106	-	-	-	147,0	-	-	-	-	-	131,0	-	108	-	-	-	-	127,0	-	-	-	-	126,0	-	110	-	-	-	-	124,0	-	-	-	-	121,0	-	114	-	-	-	-	118,0	-	-	-	-	112,0	-	118	-	-	-	-	113,0	-	-	-	-	103,0	-	120	-	-	-	-	110,0	-	-	-	-	97,7	-	122	-	-	-	-	-	-	-	-	-	92,5	-	126	-	-	-	-	-	-	-	-	-	81,5	-	128	-	-	-	-	-	-	-	-	80,0	76,5	-	130	-	-	-	-	-	-	-	-	78,0	71,5	-	134	-	-	-	-	-	-	-	-	-	61,0	-	138	-	-	-	-	-	-	-	-	-	52,0	-	142	-	-	-	-	-	-	-	-	-	47,8	-												
SWSL											SFSL																																																																																																																																																																																																																																																																																																																																																																																																																																																																																				
0 t											0 t - 640 t																																																																																																																																																																																																																																																																																																																																																																																																																																																																																				
85° 85° 75° 65° 55° 45°																																																																																																																																																																																																																																																																																																																																																																																																																																																																																															
m	t	t	t	t	t	t	t	t	t	t	t																																																																																																																																																																																																																																																																																																																																																																																																																																																																																				
30	-	220,0*	-	-	-	-	-	-	-	-	-																																																																																																																																																																																																																																																																																																																																																																																																																																																																																				
34	-	215,0*	-	-	-	-	-	-	-	-	-																																																																																																																																																																																																																																																																																																																																																																																																																																																																																				
38	120,0	230,0	-	-	-	-	-	-	-	224,0	-																																																																																																																																																																																																																																																																																																																																																																																																																																																																																				
42	106,0	225,0	-	-	-	-	-	-	-	224,0	-																																																																																																																																																																																																																																																																																																																																																																																																																																																																																				
46	95,0	220,0	-	-	-	-	-	-	-	224,0	-																																																																																																																																																																																																																																																																																																																																																																																																																																																																																				
50	85,5	215,0	-	-	-	-	-	-	-	224,0	-																																																																																																																																																																																																																																																																																																																																																																																																																																																																																				
54	76,5	209,0	-	-	-	-	-	-	-	224,0	-																																																																																																																																																																																																																																																																																																																																																																																																																																																																																				
58	69,0	204,0	-	-	-	-	-	-	-	224,0	-																																																																																																																																																																																																																																																																																																																																																																																																																																																																																				
62	62,5	199,0	-	-	-	-	-	-	-	219,0	-																																																																																																																																																																																																																																																																																																																																																																																																																																																																																				
64	59,5	195,0	233,0	-	-	-	-	-	-	216,5	-																																																																																																																																																																																																																																																																																																																																																																																																																																																																																				
66	56,5	192,0	233,0	-	-	-	-	-	-	214,0	-																																																																																																																																																																																																																																																																																																																																																																																																																																																																																				
70	51,5	185,0	232,0	-	-	-	-	-	-	210,0	-																																																																																																																																																																																																																																																																																																																																																																																																																																																																																				
74	46,7	169,0	226,0	-	-	-	-	-	-	205,0	-																																																																																																																																																																																																																																																																																																																																																																																																																																																																																				
78	42,4	147,0	222,0	-	-	-	-	-	-	198,0	-																																																																																																																																																																																																																																																																																																																																																																																																																																																																																				
82	-	-	202,0	-	-	-	-	-	-	193,0	-																																																																																																																																																																																																																																																																																																																																																																																																																																																																																				
86	-	-	185,0	-	-	-	-	-	-	188,0	-																																																																																																																																																																																																																																																																																																																																																																																																																																																																																				
88	-	-	177,0	187,0	-	-	-	-	-	182,5	-																																																																																																																																																																																																																																																																																																																																																																																																																																																																																				
90	-	-	170,0	181,0	-	-	-	-	-	177,0	-																																																																																																																																																																																																																																																																																																																																																																																																																																																																																				
94	-	-	150,0	172,0	-	-	-	-	-	164,0	-																																																																																																																																																																																																																																																																																																																																																																																																																																																																																				
98	-	-	-	163,0	-	-	-	-	-	152,0	-																																																																																																																																																																																																																																																																																																																																																																																																																																																																																				
102	-	-	-	154,0	-	-	-	-	-	141,0	-																																																																																																																																																																																																																																																																																																																																																																																																																																																																																				
106	-	-	-	147,0	-	-	-	-	-	131,0	-																																																																																																																																																																																																																																																																																																																																																																																																																																																																																				
108	-	-	-	-	127,0	-	-	-	-	126,0	-																																																																																																																																																																																																																																																																																																																																																																																																																																																																																				
110	-	-	-	-	124,0	-	-	-	-	121,0	-																																																																																																																																																																																																																																																																																																																																																																																																																																																																																				
114	-	-	-	-	118,0	-	-	-	-	112,0	-																																																																																																																																																																																																																																																																																																																																																																																																																																																																																				
118	-	-	-	-	113,0	-	-	-	-	103,0	-																																																																																																																																																																																																																																																																																																																																																																																																																																																																																				
120	-	-	-	-	110,0	-	-	-	-	97,7	-																																																																																																																																																																																																																																																																																																																																																																																																																																																																																				
122	-	-	-	-	-	-	-	-	-	92,5	-																																																																																																																																																																																																																																																																																																																																																																																																																																																																																				
126	-	-	-	-	-	-	-	-	-	81,5	-																																																																																																																																																																																																																																																																																																																																																																																																																																																																																				
128	-	-	-	-	-	-	-	-	80,0	76,5	-																																																																																																																																																																																																																																																																																																																																																																																																																																																																																				
130	-	-	-	-	-	-	-	-	78,0	71,5	-																																																																																																																																																																																																																																																																																																																																																																																																																																																																																				
134	-	-	-	-	-	-	-	-	-	61,0	-																																																																																																																																																																																																																																																																																																																																																																																																																																																																																				
138	-	-	-	-	-	-	-	-	-	52,0	-																																																																																																																																																																																																																																																																																																																																																																																																																																																																																				
142	-	-	-	-	-	-	-	-	-	47,8	-																																																																																																																																																																																																																																																																																																																																																																																																																																																																																				
<table border="1"> <thead> <tr> <th colspan="11">SWSL</th> <th>SFSL</th> </tr> <tr> <th colspan="11">0 t</th> <th>0 t - 640 t</th> </tr> <tr> <th colspan="11">85° 85° 75° 65° 55° 45°</th> <th></th> </tr> <tr> <th>m</th> <th>t</th> <th>t</th> <th>t</th> <th>t</th> <th>t</th> <th>t</th> <th>t</th> <th>t</th> <th>t</th> <th>t</th> <th>t</th> </tr> </thead> <tbody> <tr><td>34</td><td>-</td><td>180,0*</td><td>-</td><td>-</td><td>-</td><td>-</td><td>-</td><td>-</td><td>-</td><td>-</td><td>-</td></tr> <tr><td>38</td><td>-</td><td>175,0*</td><td>-</td><td>-</td><td>-</td><td>-</td><td>-</td><td>-</td><td>-</td><td>-</td><td>-</td></tr> <tr><td>42</td><td>95,5</td><td>186,0</td><td>-</td><td>-</td><td>-</td><td>-</td><td>-</td><td>-</td><td>-</td><td>182,0</td><td>-</td></tr> <tr><td>46</td><td>85,0</td><td>184,0</td><td>-</td><td>-</td><td>-</td><td>-</td><td>-</td><td>-</td><td>-</td><td>182,0</td><td>-</td></tr> <tr><td>50</td><td>75,5</td><td>180,0</td><td>-</td><td>-</td><td>-</td><td>-</td><td>-</td><td>-</td><td>-</td><td>182,0</td><td>-</td></tr> <tr><td>54</td><td>67,0</td><td>177,0</td><td>-</td><td>-</td><td>-</td><td>-</td><td>-</td><td>-</td><td>-</td><td>182,0</td><td>-</td></tr> <tr><td>58</td><td>60,0</td><td>173,0</td><td>-</td><td>-</td><td>-</td><td>-</td><td>-</td><td>-</td><td>-</td><td>182,0</td><td>-</td></tr> <tr><td>62</td><td>53,5</td><td>169,0</td><td>-</td><td>-</td><td>-</td><td>-</td><td>-</td><td>-</td><td>-</td><td>182,0</td><td>-</td></tr> <tr><td>66</td><td>47,9</td><td>166,0</td><td>-</td><td>-</td><td>-</td><td>-</td><td>-</td><td>-</td><td>-</td><td>180,0</td><td>-</td></tr> <tr><td>70</td><td>42,8</td><td>162,0</td><td>186,0</td><td>-</td><td>-</td><td>-</td><td>-</td><td>-</td><td>-</td><td>177,0</td><td>-</td></tr> <tr><td>74</td><td>38,1</td><td>157,0</td><td>186,0</td><td>-</td><td>-</td><td>-</td><td>-</td><td>-</td><td>-</td><td>174,0</td><td>-</td></tr> <tr><td>78</td><td>33,9</td><td>152,0</td><td>186,0</td><td>-</td><td>-</td><td>-</td><td>-</td><td>-</td><td>-</td><td>171,0</td><td>-</td></tr> <tr><td>82</td><td>30,1</td><td>141,0</td><td>185,0</td><td>-</td><td>-</td><td>-</td><td>-</td><td>-</td><td>-</td><td>168,0</td><td>-</td></tr> <tr><td>86</td><td>26,6</td><td>125,0</td><td>179,0</td><td>-</td><td>-</td><td>-</td><td>-</td><td>-</td><td>-</td><td>163,0</td><td>-</td></tr> <tr><td>88</td><td>24,9</td><td>117,0</td><td>172,0</td><td>-</td><td>-</td><td>-</td><td>-</td><td>-</td><td>-</td><td>161,5</td><td>-</td></tr> <tr><td>90</td><td>-</td><td>-</td><td>164,0</td><td>-</td><td>-</td><td>-</td><td>-</td><td>-</td><td>-</td><td>160,0</td><td>-</td></tr> <tr><td>94</td><td>-</td><td>-</td><td>151,0</td><td>-</td><td>-</td><td>-</td><td>-</td><td>-</td><td>-</td><td>157,0</td><td>-</td></tr> <tr><td>96</td><td>-</td><td>-</td><td>145,0</td><td>158,0</td><td>-</td><td>-</td><td>-</td><td>-</td><td>-</td><td>153,0</td><td>-</td></tr> <tr><td>98</td><td>-</td><td>-</td><td>139,0</td><td>154,0</td><td>-</td><td>-</td><td>-</td><td>-</td><td>-</td><td>149,0</td><td>-</td></tr> <tr><td>102</td><td>-</td><td>-</td><td>129,0</td><td>145,0</td><td>-</td><td>-</td><td>-</td><td>-</td><td>-</td><td>138,0</td><td>-</td></tr> <tr><td>104</td><td>-</td><td>-</td><td>121,0</td><td>142,0</td><td>-</td><td>-</td><td>-</td><td>-</td><td>-</td><td>133,0</td><td>-</td></tr> <tr><td>106</td><td>-</td><td>-</td><td>-</td><td>138,0</td><td>-</td><td>-</td><td>-</td><td>-</td><td>-</td><td>128,0</td><td>-</td></tr> <tr><td>110</td><td>-</td><td>-</td><td>-</td><td>131,0</td><td>-</td><td>-</td><td>-</td><td>-</td><td>-</td><td>118,0</td><td>-</td></tr> <tr><td>114</td><td>-</td><td>-</td><td>-</td><td>125,0</td><td>-</td><td>-</td><td>-</td><td>-</td><td>-</td><td>110,0</td><td>-</td></tr> <tr><td>118</td><td>-</td><td>-</td><td>-</td><td>119,0</td><td>103,0</td><td>-</td><td>-</td><td>-</td><td>-</td><td>101,0</td><td>-</td></tr> <tr><td>122</td><td>-</td><td>-</td><td>-</td><td>-</td><td>98,5</td><td>-</td><td>-</td><td>-</td><td>-</td><td>94,0</td><td>-</td></tr> <tr><td>126</td><td>-</td><td>-</td><td>-</td><td>-</td><td>93,5</td><td>-</td><td>-</td><td>-</td><td>-</td><td>85,5</td><td>-</td></tr> <tr><td>130</td><td>-</td><td>-</td><td>-</td><td>-</td><td>89,5</td><td>-</td><td>-</td><td>-</td><td>-</td><td>75,5</td><td>-</td></tr> <tr><td>132</td><td>-</td><td>-</td><td>-</td><td>-</td><td>87,5</td><td>-</td><td>-</td><td>-</td><td>-</td><td>71,0</td><td>-</td></tr> <tr><td>134</td><td>-</td><td>-</td><td>-</td><td>-</td><td>-</td><td>-</td><td>-</td><td>-</td><td>-</td><td>66,5</td><td>-</td></tr> <tr><td>138</td><td>-</td><td>-</td><td>-</td><td>-</td><td>-</td><td>-</td><td>-</td><td>-</td><td>60,0</td><td>57,5</td><td>-</td></tr> <tr><td>142</td><td>-</td><td>-</td><td>-</td><td>-</td><td>-</td><td>-</td><td>-</td><td>-</td><td>57,0</td><td>48,7</td><td>-</td></tr> <tr><td>146</td><td>-</td><td>-</td><td>-</td><td>-</td><td>-</td><td>-</td><td>-</td><td>-</td><td>-</td><td>41,5</td><td>-</td></tr> <tr><td>150</td><td>-</td><td>-</td><td>-</td><td>-</td><td>-</td><td>-</td><td>-</td><td>-</td><td>-</td><td>37,2</td><td>-</td></tr> <tr><td>154</td><td>-</td><td>-</td><td>-</td><td>-</td><td>-</td><td>-</td><td>-</td><td>-</td><td>-</td><td>29,5</td><td>-</td></tr> </tbody> </table>												SWSL											SFSL	0 t											0 t - 640 t	85° 85° 75° 65° 55° 45°												m	t	t	t	t	t	t	t	t	t	t	t	34	-	180,0*	-	-	-	-	-	-	-	-	-	38	-	175,0*	-	-	-	-	-	-	-	-	-	42	95,5	186,0	-	-	-	-	-	-	-	182,0	-	46	85,0	184,0	-	-	-	-	-	-	-	182,0	-	50	75,5	180,0	-	-	-	-	-	-	-	182,0	-	54	67,0	177,0	-	-	-	-	-	-	-	182,0	-	58	60,0	173,0	-	-	-	-	-	-	-	182,0	-	62	53,5	169,0	-	-	-	-	-	-	-	182,0	-	66	47,9	166,0	-	-	-	-	-	-	-	180,0	-	70	42,8	162,0	186,0	-	-	-	-	-	-	177,0	-	74	38,1	157,0	186,0	-	-	-	-	-	-	174,0	-	78	33,9	152,0	186,0	-	-	-	-	-	-	171,0	-	82	30,1	141,0	185,0	-	-	-	-	-	-	168,0	-	86	26,6	125,0	179,0	-	-	-	-	-	-	163,0	-	88	24,9	117,0	172,0	-	-	-	-	-	-	161,5	-	90	-	-	164,0	-	-	-	-	-	-	160,0	-	94	-	-	151,0	-	-	-	-	-	-	157,0	-	96	-	-	145,0	158,0	-	-	-	-	-	153,0	-	98	-	-	139,0	154,0	-	-	-	-	-	149,0	-	102	-	-	129,0	145,0	-	-	-	-	-	138,0	-	104	-	-	121,0	142,0	-	-	-	-	-	133,0	-	106	-	-	-	138,0	-	-	-	-	-	128,0	-	110	-	-	-	131,0	-	-	-	-	-	118,0	-	114	-	-	-	125,0	-	-	-	-	-	110,0	-	118	-	-	-	119,0	103,0	-	-	-	-	101,0	-	122	-	-	-	-	98,5	-	-	-	-	94,0	-	126	-	-	-	-	93,5	-	-	-	-	85,5	-	130	-	-	-	-	89,5	-	-	-	-	75,5	-	132	-	-	-	-	87,5	-	-	-	-	71,0	-	134	-	-	-	-	-	-	-	-	-	66,5	-	138	-	-	-	-	-	-	-	-	60,0	57,5	-	142	-	-	-	-	-	-	-	-	57,0	48,7	-	146	-	-	-	-	-	-	-	-	-	41,5	-	150	-	-	-	-	-	-	-	-	-	37,2	-	154	-	-	-	-	-	-	-	-	-	29,5	-
SWSL											SFSL																																																																																																																																																																																																																																																																																																																																																																																																																																																																																				
0 t											0 t - 640 t																																																																																																																																																																																																																																																																																																																																																																																																																																																																																				
85° 85° 75° 65° 55° 45°																																																																																																																																																																																																																																																																																																																																																																																																																																																																																															
m	t	t	t	t	t	t	t	t	t	t	t																																																																																																																																																																																																																																																																																																																																																																																																																																																																																				
34	-	180,0*	-	-	-	-	-	-	-	-	-																																																																																																																																																																																																																																																																																																																																																																																																																																																																																				
38	-	175,0*	-	-	-	-	-	-	-	-	-																																																																																																																																																																																																																																																																																																																																																																																																																																																																																				
42	95,5	186,0	-	-	-	-	-	-	-	182,0	-																																																																																																																																																																																																																																																																																																																																																																																																																																																																																				
46	85,0	184,0	-	-	-	-	-	-	-	182,0	-																																																																																																																																																																																																																																																																																																																																																																																																																																																																																				
50	75,5	180,0	-	-	-	-	-	-	-	182,0	-																																																																																																																																																																																																																																																																																																																																																																																																																																																																																				
54	67,0	177,0	-	-	-	-	-	-	-	182,0	-																																																																																																																																																																																																																																																																																																																																																																																																																																																																																				
58	60,0	173,0	-	-	-	-	-	-	-	182,0	-																																																																																																																																																																																																																																																																																																																																																																																																																																																																																				
62	53,5	169,0	-	-	-	-	-	-	-	182,0	-																																																																																																																																																																																																																																																																																																																																																																																																																																																																																				
66	47,9	166,0	-	-	-	-	-	-	-	180,0	-																																																																																																																																																																																																																																																																																																																																																																																																																																																																																				
70	42,8	162,0	186,0	-	-	-	-	-	-	177,0	-																																																																																																																																																																																																																																																																																																																																																																																																																																																																																				
74	38,1	157,0	186,0	-	-	-	-	-	-	174,0	-																																																																																																																																																																																																																																																																																																																																																																																																																																																																																				
78	33,9	152,0	186,0	-	-	-	-	-	-	171,0	-																																																																																																																																																																																																																																																																																																																																																																																																																																																																																				
82	30,1	141,0	185,0	-	-	-	-	-	-	168,0	-																																																																																																																																																																																																																																																																																																																																																																																																																																																																																				
86	26,6	125,0	179,0	-	-	-	-	-	-	163,0	-																																																																																																																																																																																																																																																																																																																																																																																																																																																																																				
88	24,9	117,0	172,0	-	-	-	-	-	-	161,5	-																																																																																																																																																																																																																																																																																																																																																																																																																																																																																				
90	-	-	164,0	-	-	-	-	-	-	160,0	-																																																																																																																																																																																																																																																																																																																																																																																																																																																																																				
94	-	-	151,0	-	-	-	-	-	-	157,0	-																																																																																																																																																																																																																																																																																																																																																																																																																																																																																				
96	-	-	145,0	158,0	-	-	-	-	-	153,0	-																																																																																																																																																																																																																																																																																																																																																																																																																																																																																				
98	-	-	139,0	154,0	-	-	-	-	-	149,0	-																																																																																																																																																																																																																																																																																																																																																																																																																																																																																				
102	-	-	129,0	145,0	-	-	-	-	-	138,0	-																																																																																																																																																																																																																																																																																																																																																																																																																																																																																				
104	-	-	121,0	142,0	-	-	-	-	-	133,0	-																																																																																																																																																																																																																																																																																																																																																																																																																																																																																				
106	-	-	-	138,0	-	-	-	-	-	128,0	-																																																																																																																																																																																																																																																																																																																																																																																																																																																																																				
110	-	-	-	131,0	-	-	-	-	-	118,0	-																																																																																																																																																																																																																																																																																																																																																																																																																																																																																				
114	-	-	-	125,0	-	-	-	-	-	110,0	-																																																																																																																																																																																																																																																																																																																																																																																																																																																																																				
118	-	-	-	119,0	103,0	-	-	-	-	101,0	-																																																																																																																																																																																																																																																																																																																																																																																																																																																																																				
122	-	-	-	-	98,5	-	-	-	-	94,0	-																																																																																																																																																																																																																																																																																																																																																																																																																																																																																				
126	-	-	-	-	93,5	-	-	-	-	85,5	-																																																																																																																																																																																																																																																																																																																																																																																																																																																																																				
130	-	-	-	-	89,5	-	-	-	-	75,5	-																																																																																																																																																																																																																																																																																																																																																																																																																																																																																				
132	-	-	-	-	87,5	-	-	-	-	71,0	-																																																																																																																																																																																																																																																																																																																																																																																																																																																																																				
134	-	-	-	-	-	-	-	-	-	66,5	-																																																																																																																																																																																																																																																																																																																																																																																																																																																																																				
138	-	-	-	-	-	-	-	-	60,0	57,5	-																																																																																																																																																																																																																																																																																																																																																																																																																																																																																				
142	-	-	-	-	-	-	-	-	57,0	48,7	-																																																																																																																																																																																																																																																																																																																																																																																																																																																																																				
146	-	-	-	-	-	-	-	-	-	41,5	-																																																																																																																																																																																																																																																																																																																																																																																																																																																																																				
150	-	-	-	-	-	-	-	-	-	37,2	-																																																																																																																																																																																																																																																																																																																																																																																																																																																																																				
154	-	-	-	-	-	-	-	-	-	29,5	-																																																																																																																																																																																																																																																																																																																																																																																																																																																																																				

6 m steps of luffing jib is standard · 6 m Stufung der Wippe ist Standard · Des paliers de 6 m sont de série pour la fléchette

Main boom angle 88°, 85°, 75°, 65°, 55° and 45°; capacities for intermediate boom positions are calculated by the crane control system IC-1  
 Hauptauslegerwinkel 88°, 85°, 75°, 65°, 55° und 45°; Traglasten für Zwischenstellungen des Hauptauslegers werden von der Kransteuerung IC-1 berechnet

Jarret de flèche principale 88°, 85°, 75°, 65°, 55° et 45° ; le système de commande de la grue IC-1 calcule les charges pour les positions intermédiaires de la flèche

\* Main boom angle 88° · Hauptauslegerwinkel 88° · Jarret de flèche principale 88°

295 t + 60 t ZB		19-30 m		10,5 m		9.8 m/s		360°		ISO		
84 m + 96 m						84 m + 108 m						
		SWSL					SFSL					
		0 t		0 t - 640 t								
		85°	85°	75°	65°	55°	45°					
m	t	t	t	t	t	t	t	t	t			
38	-	145,0*	-	-	-	-	-	-	-			
42	-	142,0*	-	-	-	-	-	-	-			
46	76,5	150,0	-	-	-	-	-	-	147,0			
50	67,5	148,0	-	-	-	-	-	-	147,0			
54	59,5	146,0	-	-	-	-	-	-	147,0			
58	52,5	143,0	-	-	-	-	-	-	147,0			
62	46,7	141,0	-	-	-	-	-	-	147,0			
66	41,2	138,0	-	-	-	-	-	-	147,0			
70	36,2	136,0	-	-	-	-	-	-	146,0			
74	31,7	133,0	-	-	-	-	-	-	144,0			
76	29,6	132,0	146,0	-	-	-	-	-	143,0			
78	27,6	131,0	146,0	-	-	-	-	-	142,0			
80	25,7	129,0	146,0	-	-	-	-	-	141,0			
82	23,9	127,0	146,0	-	-	-	-	-	140,0			
86	20,4	123,0	146,0	-	-	-	-	-	138,0			
90	17,3	117,5	146,0	-	-	-	-	-	136,0			
94	14,4	108,0	146,0	-	-	-	-	-	134,0			
98	11,7	95,7	137,0	-	-	-	-	-	130,0			
100	10,5	89,5	132,0	-	-	-	-	-	129,0			
102	-	-	127,0	-	-	-	-	-	128,0			
104	-	-	122,0	124,0	-	-	-	-	127,0			
106	-	-	117,0	124,0	-	-	-	-	126,0			
110	-	-	108,0	123,0	-	-	-	-	119,0			
114	-	-	99,5	120,0	-	-	-	-	111,0			
116	-	-	93,0	117,0	-	-	-	-	106,5			
118	-	-	-	114,0	-	-	-	-	102,0			
122	-	-	-	108,0	-	-	-	-	95,0			
126	-	-	-	103,0	-	-	-	-	87,5			
128	-	-	-	101,0	86,0	-	-	-	84,2			
130	-	-	-	97,5	84,0	-	-	-	81,0			
134	-	-	-	-	80,0	-	-	-	73,0			
138	-	-	-	-	76,0	-	-	-	64,0			
142	-	-	-	-	73,0	-	-	-	56,0			
146	-	-	-	-	-	-	-	-	48,1			
148	-	-	-	-	-	-	-	46,2	44,2			
150	-	-	-	-	-	-	-	44,8	40,3			
154	-	-	-	-	-	-	-	42,0	33,0			
158	-	-	-	-	-	-	-	-	28,7			
162	-	-	-	-	-	-	-	-	23,4			
40	-	117,0*	-	-	-	-	-	-	-			
42	-	117,0*	-	-	-	-	-	-	-			
46	-	114,0*	-	-	-	-	-	-	-			
50	60,0	119,0	-	-	-	-	-	-	118,0			
54	52,5	118,0	-	-	-	-	-	-	118,0			
58	45,8	116,0	-	-	-	-	-	-	118,0			
62	39,9	114,0	-	-	-	-	-	-	117,0			
66	34,5	113,0	-	-	-	-	-	-	117,0			
70	29,8	111,0	-	-	-	-	-	-	116,0			
74	25,3	109,0	-	-	-	-	-	-	116,0			
78	21,4	107,0	-	-	-	-	-	-	114,0			
82	17,7	106,0	112,0	-	-	-	-	-	112,0			
86	14,4	104,0	112,0	-	-	-	-	-	110,0			
88	12,8	103,0	112,0	-	-	-	-	-	109,0			
90	-	100,2	112,0	-	-	-	-	-	108,0			
94	-	94,5	112,0	-	-	-	-	-	106,0			
98	-	88,7	112,0	-	-	-	-	-	105,0			
102	-	83,2	112,0	-	-	-	-	-	103,0			
106	-	77,7	112,0	-	-	-	-	-	101,0			
110	-	70,2	104,0	97,5	-	-	-	-	98,0			
112	-	65,5	100,0	97,5	-	-	-	-	97,0			
114	-	-	96,0	97,5	-	-	-	-	96,0			
118	-	-	89,0	97,5	-	-	-	-	94,0			
122	-	-	82,5	97,5	-	-	-	-	92,0			
126	-	-	74,5	97,0	-	-	-	-	86,5			
128	-	-	69,5	94,5	-	-	-	-	83,0			
130	-	-	-	92,5	-	-	-	-	79,5			
134	-	-	-	85,5	-	-	-	-	73,0			
136	-	-	-	82,5	71,5	-	-	-	70,0			
138	-	-	-	79,5	69,5	-	-	-	67,0			
142	-	-	-	74,0	66,0	-	-	-	59,0			
146	-	-	-	-	62,0	-	-	-	51,5			
150	-	-	-	-	58,5	-	-	-	44,5			
154	-	-	-	-	55,5	-	-	-	37,3			
158	-	-	-	-	-	-	-	31,9	30,4			
162	-	-	-	-	-	-	-	29,5	23,6			
166	-	-	-	-	-	-	-	27,3	18,6			
170	-	-	-	-	-	-	-	-	14,7			

6 m steps of luffing jib is standard · 6 m Stufung der Wippe ist Standard · Des paliers de 6 m sont de série pour la fléchette

Main boom angle 88°, 85°, 75°, 65°, 55° and 45°; capacities for intermediate boom positions are calculated by the crane control system IC-1  
 Hauptauslegerwinkel 88°, 85°, 75°, 65°, 55° und 45°; Traglasten für Zwischenstellungen des Hauptauslegers werden von der Kransteuerung IC-1 berechnet

Jarret de flèche principale 88°, 85°, 75°, 65°, 55° et 45° ; le système de commande de la grue IC-1 calcule les charges pour les positions intermédiaires de la flèche

\* Main boom angle 88° · Hauptauslegerwinkel 88° · Jarret de flèche principale 88°

295 t + 60 t ZB		19-30 m		10,5 m		9.8 m/s		360°		ISO			
90 m + 36 m						90 m + 48 m							
		SWSL					SFSL						
		0 t		0 t - 640 t									
		85°		85°		75°		65°		55°		45°	
m	t	t	t	t	t	t	t	t	t	t	t	t	t
20	-	375,0*	-	-	-	-	-	-	-	-	-	-	-
22	-	364,0*	-	-	-	-	-	-	-	-	-	-	-
24	-	353,0*	-	-	-	-	-	-	-	-	-	-	-
26	212,0	394,0	-	-	-	-	-	-	-	-	-	381,0	-
28	197,0	385,0	-	-	-	-	-	-	-	-	-	381,0	-
30	184,0	376,0	-	-	-	-	-	-	-	-	-	381,0	-
34	162,0	358,0	-	-	-	-	-	-	-	-	-	381,0	-
38	144,0	341,0	-	-	-	-	-	-	-	-	-	381,0	-
42	129,0	328,0	-	-	-	-	-	-	-	-	-	381,0	-
44	122,0	321,0	-	-	-	-	-	-	-	-	-	377,0	-
46	-	-	-	-	-	-	-	-	-	-	-	370,0	-
47	-	-	393,0	-	-	-	-	-	-	-	-	367,0	-
50	-	-	389,0	-	-	-	-	-	-	-	-	352,0	-
54	-	-	374,0	-	-	-	-	-	-	-	-	340,0	-
58	-	-	349,0	-	-	-	-	-	-	-	-	328,0	-
60	-	-	334,0	-	-	-	-	-	-	-	-	312,5	-
62	-	-	-	-	-	-	-	-	-	-	-	297,0	-
66	-	-	-	-	-	-	-	-	-	-	-	271,0	-
67	-	-	-	268,0	-	-	-	-	-	-	-	265,0	-
70	-	-	-	255,0	-	-	-	-	-	-	-	247,0	-
74	-	-	-	239,0	-	-	-	-	-	-	-	227,0	-
76	-	-	-	232,0	-	-	-	-	-	-	-	217,5	-
78	-	-	-	-	-	-	-	-	-	-	-	208,0	-
82	-	-	-	-	-	-	-	-	-	-	-	191,0	-
84	-	-	-	-	185,0	-	-	-	-	-	-	183,5	-
86	-	-	-	-	180,0	-	-	-	-	-	-	176,0	-
89	-	-	-	-	173,0	-	-	-	-	-	-	165,5	-
90	-	-	-	-	-	-	-	-	-	-	-	162,0	-
94	-	-	-	-	-	-	-	-	-	-	-	150,0	-
98	-	-	-	-	-	-	-	-	-	-	-	136,0	-
102	-	-	-	-	-	-	-	-	-	-	-	121,0	-
106	-	-	-	-	-	-	-	-	-	-	-	106,0	-
110	-	-	-	-	-	-	-	-	-	-	-	91,0	-
24	-	303,0*	-	-	-	-	-	-	-	-	-	-	-
26	-	295,0*	-	-	-	-	-	-	-	-	-	-	-
28	-	288,0*	-	-	-	-	-	-	-	-	-	-	-
30	171,0	316,0	-	-	-	-	-	-	-	-	-	309,0	-
34	150,0	307,0	-	-	-	-	-	-	-	-	-	309,0	-
38	133,0	296,0	-	-	-	-	-	-	-	-	-	309,0	-
42	119,0	284,0	-	-	-	-	-	-	-	-	-	309,0	-
46	107,0	272,0	-	-	-	-	-	-	-	-	-	309,0	-
50	96,5	263,0	-	-	-	-	-	-	-	-	-	304,0	-
54	87,5	254,0	321,0	-	-	-	-	-	-	-	-	296,0	-
56	83,0	249,0	317,0	-	-	-	-	-	-	-	-	291,0	-
58	-	-	313,0	-	-	-	-	-	-	-	-	286,0	-
62	-	-	303,0	-	-	-	-	-	-	-	-	274,0	-
66	-	-	293,0	-	-	-	-	-	-	-	-	265,0	-
70	-	-	263,0	-	-	-	-	-	-	-	-	251,0	-
72	-	-	249,0	-	-	-	-	-	-	-	-	240,5	-
74	-	-	-	232,0	-	-	-	-	-	-	-	230,0	-
78	-	-	-	218,0	-	-	-	-	-	-	-	211,0	-
82	-	-	-	205,0	-	-	-	-	-	-	-	194,0	-
86	-	-	-	194,0	-	-	-	-	-	-	-	179,0	-
90	-	-	-	-	-	-	-	-	-	-	-	165,0	-
94	-	-	-	-	-	155,0	-	-	-	-	-	152,0	-
98	-	-	-	-	-	147,0	-	-	-	-	-	141,0	-
100	-	-	-	-	-	143,0	-	-	-	-	-	135,5	-
102	-	-	-	-	-	-	-	-	-	-	-	130,0	-
106	-	-	-	-	-	-	-	-	-	-	-	119,0	-
110	-	-	-	-	-	-	-	-	-	108,0	-	106,0	-
113	-	-	-	-	-	-	-	-	-	104,0	-	96,2	-
114	-	-	-	-	-	-	-	-	-	-	-	93,0	-
118	-	-	-	-	-	-	-	-	-	-	-	80,5	-
122	-	-	-	-	-	-	-	-	-	-	-	68,0	-

6 m steps of luffing jib is standard · 6 m Stufung der Wippe ist Standard · Des paliers de 6 m sont de série pour la fléchette

Main boom angle 88°, 85°, 75°, 65°, 55° and 45°; capacities for intermediate boom positions are calculated by the crane control system IC-1  
Hauptauslegerwinkel 88°, 85°, 75°, 65°, 55° und 45°; Traglasten für Zwischenstellungen des Hauptauslegers werden von der Kransteuerung IC-1 berechnet

Jarret de flèche principale 88°, 85°, 75°, 65°, 55° et 45° ; le système de commande de la grue IC-1 calcule les charges pour les positions intermédiaires de la flèche

\* Main boom angle 88° · Hauptauslegerwinkel 88° · Jarret de flèche principale 88°

295 t + 60 t ZB		19-30 m		10,5 m		9.8 m/s		360°		ISO		
90 m + 60 m						90 m + 72 m						
		SWSL					SFSL					
		0 t		0 t - 640 t								
		85°	85°	75°	65°	55°	45°					
m	t	t	t	t	t	t	t	t	t			
26	-	249,0*	-	-	-	-	-	-	-			
28	-	247,0*	-	-	-	-	-	-	-			
30	-	242,0*	-	-	-	-	-	-	-			
34	140,0	259,0	-	-	-	-	-	-	252,0			
38	123,0	253,0	-	-	-	-	-	-	252,0			
42	110,0	245,0	-	-	-	-	-	-	252,0			
46	98,5	237,0	-	-	-	-	-	-	252,0			
50	89,0	229,0	-	-	-	-	-	-	252,0			
54	80,0	221,0	-	-	-	-	-	-	251,0			
58	72,5	215,0	-	-	-	-	-	-	245,0			
60	69,0	211,0	262,0	-	-	-	-	-	242,0			
62	66,0	208,0	262,0	-	-	-	-	-	239,0			
66	60,0	201,0	255,0	-	-	-	-	-	233,0			
68	57,5	187,0	252,0	-	-	-	-	-	227,0			
70	-	-	249,0	-	-	-	-	-	224,0			
74	-	-	243,0	-	-	-	-	-	218,0			
78	-	-	225,0	-	-	-	-	-	211,0			
82	-	-	204,0	203,0	-	-	-	-	200,0			
84	-	-	195,0	197,0	-	-	-	-	192,5			
86	-	-	-	191,0	-	-	-	-	185,0			
90	-	-	-	181,0	-	-	-	-	171,0			
94	-	-	-	171,0	-	-	-	-	158,0			
98	-	-	-	163,0	-	-	-	-	146,0			
102	-	-	-	-	-	-	-	-	135,0			
104	-	-	-	-	133,0	-	-	-	130,0			
106	-	-	-	-	129,0	-	-	-	125,0			
110	-	-	-	-	123,0	-	-	-	116,0			
112	-	-	-	-	120,0	-	-	-	111,5			
114	-	-	-	-	-	-	-	-	107,0			
118	-	-	-	-	-	-	-	-	95,5			
120	-	-	-	-	-	-	-	91,0	89,7			
122	-	-	-	-	-	-	-	88,5	84,0			
124	-	-	-	-	-	-	-	86,0	78,5			
126	-	-	-	-	-	-	-	-	73,0			
130	-	-	-	-	-	-	-	-	62,5			
134	-	-	-	-	-	-	-	-	52,5			
30	-	203,0*	-	-	-	-	-	-	-			
34	-	198,0*	-	-	-	-	-	-	-			
38	114,0	211,0	-	-	-	-	-	-	206,0			
42	101,0	207,0	-	-	-	-	-	-	206,0			
46	90,5	202,0	-	-	-	-	-	-	206,0			
50	81,0	197,0	-	-	-	-	-	-	206,0			
54	73,0	192,0	-	-	-	-	-	-	206,0			
58	65,5	187,0	-	-	-	-	-	-	206,0			
62	59,0	181,0	-	-	-	-	-	-	203,0			
66	53,5	176,0	212,0	-	-	-	-	-	199,0			
70	48,5	170,0	212,0	-	-	-	-	-	195,0			
74	43,9	164,0	211,0	-	-	-	-	-	191,0			
78	39,7	150,0	204,0	-	-	-	-	-	186,0			
80	37,8	138,0	203,0	-	-	-	-	-	183,0			
82	-	-	202,0	-	-	-	-	-	181,0			
86	-	-	191,0	-	-	-	-	-	177,0			
90	-	-	175,0	175,0	-	-	-	-	173,0			
94	-	-	159,0	166,0	-	-	-	-	160,0			
98	-	-	-	157,0	-	-	-	-	148,0			
102	-	-	-	149,0	-	-	-	-	137,0			
106	-	-	-	142,0	-	-	-	-	127,0			
110	-	-	-	135,0	-	-	-	-	117,0			
112	-	-	-	-	114,0	-	-	-	113,0			
114	-	-	-	-	112,0	-	-	-	109,0			
118	-	-	-	-	106,0	-	-	-	100,0			
122	-	-	-	-	102,0	-	-	-	93,0			
124	-	-	-	-	99,5	-	-	-	88,0			
126	-	-	-	-	-	-	-	-	83,0			
130	-	-	-	-	-	-	-	-	73,0			
132	-	-	-	-	-	-	-	71,5	68,2			
134	-	-	-	-	-	-	-	69,5	63,5			
136	-	-	-	-	-	-	-	67,5	58,7			
138	-	-	-	-	-	-	-	-	54,0			
142	-	-	-	-	-	-	-	-	44,8			
146	-	-	-	-	-	-	-	-	40,7			

6 m steps of luffing jib is standard · 6 m Stufung der Wippe ist Standard · Des paliers de 6 m sont de série pour la fléchette

Main boom angle 88°, 85°, 75°, 65°, 55° and 45°; capacities for intermediate boom positions are calculated by the crane control system IC-1  
Hauptauslegerwinkel 88°, 85°, 75°, 65°, 55° und 45°; Traglasten für Zwischenstellungen des Hauptauslegers werden von der Kransteuerung IC-1 berechnet

Jarret de flèche principale 88°, 85°, 75°, 65°, 55° et 45° ; le système de commande de la grue IC-1 calcule les charges pour les positions intermédiaires de la flèche

\* Main boom angle 88° · Hauptauslegerwinkel 88° · Jarret de flèche principale 88°

295 t + 60 t ZB		19-30 m		10,5 m		9.8 m/s		360°		ISO		
90 m + 84 m						90 m + 96 m						
		SWSL					SFSL					
		0 t		0 t - 640 t								
		85°	85°	75°	65°	55°	45°					
m	t	t	t	t	t	t	t	t	t			
34	-	166,0*	-	-	-	-	-	-	-			
38	-	161,0*	-	-	-	-	-	-	-			
42	90,5	171,0	-	-	-	-	-	-	168,0			
46	80,0	169,0	-	-	-	-	-	-	168,0			
50	71,0	165,0	-	-	-	-	-	-	168,0			
54	63,0	162,0	-	-	-	-	-	-	168,0			
58	56,0	158,0	-	-	-	-	-	-	168,0			
62	50,0	155,0	-	-	-	-	-	-	168,0			
66	44,7	151,0	-	-	-	-	-	-	167,0			
70	39,8	148,0	-	-	-	-	-	-	164,0			
72	37,5	146,0	170,0	-	-	-	-	-	162,5			
74	35,3	143,0	170,0	-	-	-	-	-	161,0			
78	31,2	139,0	170,0	-	-	-	-	-	159,0			
82	27,5	134,5	169,0	-	-	-	-	-	156,0			
84	25,8	132,0	169,0	-	-	-	-	-	155,0			
86	24,1	125,5	168,0	-	-	-	-	-	154,0			
88	22,5	119,0	166,0	-	-	-	-	-	150,0			
90	-	-	164,0	-	-	-	-	-	149,0			
94	-	-	155,0	-	-	-	-	-	146,0			
98	-	-	143,0	148,0	-	-	-	-	143,0			
102	-	-	132,0	140,0	-	-	-	-	134,0			
106	-	-	119,0	133,0	-	-	-	-	124,0			
110	-	-	-	126,0	-	-	-	-	115,0			
114	-	-	-	120,0	-	-	-	-	106,0			
118	-	-	-	114,0	-	-	-	-	98,0			
120	-	-	-	111,0	-	-	-	-	94,0			
122	-	-	-	-	92,0	-	-	-	90,0			
126	-	-	-	-	87,5	-	-	-	83,0			
130	-	-	-	-	83,5	-	-	-	75,5			
134	-	-	-	-	80,0	-	-	-	66,5			
138	-	-	-	-	-	-	-	-	58,0			
142	-	-	-	-	-	-	-	52,0	49,8			
146	-	-	-	-	-	-	-	49,4	41,6			
150	-	-	-	-	-	-	-	-	33,5			
154	-	-	-	-	-	-	-	-	28,7			
158	-	-	-	-	-	-	-	-	23,7			
38	-	135,0*	-	-	-	-	-	-	-			
42	-	132,0*	-	-	-	-	-	-	-			
46	72,0	137,0	-	-	-	-	-	-	136,0			
50	63,5	136,0	-	-	-	-	-	-	136,0			
54	56,0	134,0	-	-	-	-	-	-	136,0			
58	49,2	131,0	-	-	-	-	-	-	136,0			
62	43,3	129,0	-	-	-	-	-	-	136,0			
66	38,0	126,0	-	-	-	-	-	-	136,0			
70	33,1	124,0	-	-	-	-	-	-	136,0			
74	28,8	121,0	-	-	-	-	-	-	133,0			
78	24,9	119,0	133,0	-	-	-	-	-	131,0			
82	21,3	116,0	133,0	-	-	-	-	-	128,0			
86	18,0	112,0	133,0	-	-	-	-	-	126,0			
90	14,9	108,5	133,0	-	-	-	-	-	123,0			
94	12,1	105,0	132,0	-	-	-	-	-	120,0			
96	10,8	103,0	132,0	-	-	-	-	-	119,0			
98	-	97,2	132,0	-	-	-	-	-	118,0			
100	-	91,5	131,0	-	-	-	-	-	115,5			
102	-	-	130,0	-	-	-	-	-	114,0			
106	-	-	120,0	115,0	-	-	-	-	111,0			
110	-	-	111,0	115,0	-	-	-	-	109,0			
114	-	-	103,0	114,0	-	-	-	-	106,0			
118	-	-	92,0	109,0	-	-	-	-	99,0			
122	-	-	-	104,0	-	-	-	-	91,0			
126	-	-	-	99,0	-	-	-	-	84,0			
130	-	-	-	94,5	78,0	-	-	-	77,0			
132	-	-	-	92,5	76,0	-	-	-	74,0			
134	-	-	-	-	74,5	-	-	-	71,0			
138	-	-	-	-	70,5	-	-	-	64,0			
142	-	-	-	-	67,5	-	-	-	56,0			
146	-	-	-	-	64,5	-	-	-	48,4			
150	-	-	-	-	-	-	-	-	40,8			
152	-	-	-	-	-	-	-	39,0	37,1			
154	-	-	-	-	-	-	-	37,7	33,5			
158	-	-	-	-	-	-	-	35,2	26,2			
162	-	-	-	-	-	-	-	-	20,0			
166	-	-	-	-	-	-	-	-	15,9			
170	-	-	-	-	-	-	-	-	10,6			

6 m steps of luffing jib is standard · 6 m Stufung der Wippe ist Standard · Des paliers de 6 m sont de série pour la fléchette

Main boom angle 88°, 85°, 75°, 65°, 55° and 45°; capacities for intermediate boom positions are calculated by the crane control system IC-1  
 Hauptauslegerwinkel 88°, 85°, 75°, 65°, 55° und 45°; Traglasten für Zwischenstellungen des Hauptauslegers werden von der Kransteuerung IC-1 berechnet

Jarret de flèche principale 88°, 85°, 75°, 65°, 55° et 45° ; le système de commande de la grue IC-1 calcule les charges pour les positions intermédiaires de la flèche

\* Main boom angle 88° · Hauptauslegerwinkel 88° · Jarret de flèche principale 88°

295 t + 60 t ZB		19-30 m		10,5 m		9.8 m/s		360°		ISO																																																													
90 m + 108 m						96 m + 36 m																																																																	
<table border="1"> <thead> <tr> <th colspan="11">SWSL</th> <th>SFSL</th> </tr> <tr> <th colspan="12">0 t</th> </tr> <tr> <th colspan="12">0 t - 640 t</th> </tr> <tr> <th colspan="12">85° 85° 75° 65° 55° 45°</th> </tr> <tr> <th>m</th> <th>t</th> <th>t</th> <th>t</th> <th>t</th> <th>t</th> <th>t</th> <th>t</th> <th>t</th> <th>t</th> <th>t</th> <th>t</th> </tr> </thead> </table>												SWSL											SFSL	0 t												0 t - 640 t												85° 85° 75° 65° 55° 45°												m	t	t	t	t	t	t	t	t	t	t	t
SWSL											SFSL																																																												
0 t																																																																							
0 t - 640 t																																																																							
85° 85° 75° 65° 55° 45°																																																																							
m	t	t	t	t	t	t	t	t	t	t	t																																																												
40	-	108,0*	-	-	-	-	-	-	-	-	-																																																												
42	-	108,0*	-	-	-	-	-	-	-	-	-																																																												
46	-	106,0*	-	-	-	-	-	-	-	-	-																																																												
50	56,0	110,0	-	-	-	-	-	-	-	-	109,0																																																												
54	48,6	109,0	-	-	-	-	-	-	-	-	109,0																																																												
58	42,2	107,0	-	-	-	-	-	-	-	-	109,0																																																												
62	36,5	105,0	-	-	-	-	-	-	-	-	108,0																																																												
66	31,3	104,0	-	-	-	-	-	-	-	-	108,0																																																												
70	26,7	102,0	-	-	-	-	-	-	-	-	107,0																																																												
74	22,5	100,0	-	-	-	-	-	-	-	-	107,0																																																												
78	18,7	98,5	-	-	-	-	-	-	-	-	106,0																																																												
82	15,2	96,7	-	-	-	-	-	-	-	-	104,0																																																												
84	13,5	96,0	104,0	-	-	-	-	-	-	-	103,0																																																												
86	11,9	95,0	104,0	-	-	-	-	-	-	-	102,0																																																												
88	10,4	94,0	104,0	-	-	-	-	-	-	-	101,5																																																												
90	-	91,7	104,0	-	-	-	-	-	-	-	101,0																																																												
94	-	87,5	104,0	-	-	-	-	-	-	-	99,0																																																												
98	-	83,2	104,0	-	-	-	-	-	-	-	97,5																																																												
102	-	79,0	104,0	-	-	-	-	-	-	-	96,0																																																												
106	-	74,7	103,0	-	-	-	-	-	-	-	94,0																																																												
110	-	69,7	103,0	-	-	-	-	-	-	-	91,0																																																												
112	-	67,0	103,0	-	-	-	-	-	-	-	90,2																																																												
114	-	-	99,0	89,5	-	-	-	-	-	-	89,5																																																												
118	-	-	91,5	89,5	-	-	-	-	-	-	87,5																																																												
122	-	-	84,5	89,5	-	-	-	-	-	-	86,0																																																												
126	-	-	78,0	89,5	-	-	-	-	-	-	83,0																																																												
128	-	-	73,5	89,5	-	-	-	-	-	-	79,5																																																												
130	-	-	-	88,0	-	-	-	-	-	-	76,0																																																												
134	-	-	-	83,5	-	-	-	-	-	-	69,5																																																												
138	-	-	-	79,5	-	-	-	-	-	-	63,5																																																												
140	-	-	-	77,5	62,0	-	-	-	-	-	60,7																																																												
142	-	-	-	76,0	60,5	-	-	-	-	-	58,0																																																												
144	-	-	-	74,5	59,0	-	-	-	-	-	54,5																																																												
146	-	-	-	-	57,5	-	-	-	-	-	51,0																																																												
150	-	-	-	-	54,5	-	-	-	-	-	44,0																																																												
154	-	-	-	-	51,5	-	-	-	-	-	37,1																																																												
158	-	-	-	-	48,8	-	-	-	-	-	30,4																																																												
162	-	-	-	-	-	25,2	-	-	-	-	23,8																																																												
166	-	-	-	-	-	23,0	-	-	-	-	17,4																																																												
170	-	-	-	-	-	21,0	-	-	-	-	11,1																																																												

20	-	342,0\*	-	-	-	-	-	-	-	-	-
22	-	333,0\*	-	-	-	-	-	-	-	-	-
24	-	323,0\*	-	-	-	-	-	-	-	-	-
26	202,0	355,0	-	-	-	-	-	-	-	-	346,0
28	188,0	351,0	-	-	-	-	-	-	-	-	346,0
30	176,0	343,0	-	-	-	-	-	-	-	-	346,0
34	155,0	326,0	-	-	-	-	-	-	-	-	346,0
38	137,0	310,0	-	-	-	-	-	-	-	-	346,0
42	123,0	299,0	-	-	-	-	-	-	-	-	346,0
46	111,0	287,0	-	-	-	-	-	-	-	-	340,0
48	-	-	361,0	-	-	-	-	-	-	-	334,0
50	-	-	357,0	-	-	-	-	-	-	-	329,0
54	-	-	347,0	-	-	-	-	-	-	-	313,0
58	-	-	334,0	-	-	-	-	-	-	-	302,0
62	-	-	318,0	-	-	-	-	-	-	-	291,0
66	-	-	-	-	-	-	-	-	-	-	266,0
69	-	-	-	251,0	-	-	-	-	-	-	248,0
70	-	-	-	247,0	-	-	-	-	-	-	242,0
74	-	-	-	231,0	-	-	-	-	-	-	222,0
78	-	-	-	217,0	-	-	-	-	-	-	203,0
82	-	-	-	-	-	-	-	-	-	-	186,0
86	-	-	-	-	-	-	-	-	-	-	171,0
88	-	-	-	-	-	166,0	-	-	-	-	164,0
90	-	-	-	-	-	162,0	-	-	-	-	157,0
93	-	-	-	-	-	156,0	-	-	-	-	148,0
94	-	-	-	-	-	-	-	-	-	-	145,0
98	-	-	-	-	-	-	-	-	-	-	133,0
102	-	-	-	-	-	-	-	-	-	-	122,0
104	-	-	-	-	-	-	-	117,0	-	-	115,0
106	-	-	-	-	-	-	-	114,0	-	-	108,0
110	-	-	-	-	-	-	-	-	-	-	94,0
114	-	-	-	-	-	-	-	-	-	-	80,5
118	-	-	-	-	-	-	-	-	-	-	67,5

6 m steps of luffing jib is standard · 6 m Stufung der Wippe ist Standard · Des paliers de 6 m sont de série pour la fléchette

Main boom angle 88°, 85°, 75°, 65°, 55° and 45°; capacities for intermediate boom positions are calculated by the crane control system IC-1  
 Hauptauslegerwinkel 88°, 85°, 75°, 65°, 55° und 45°; Traglasten für Zwischenstellungen des Hauptauslegers werden von der Kransteuerung IC-1 berechnet

Jarret de flèche principale 88°, 85°, 75°, 65°, 55° et 45° ; le système de commande de la grue IC-1 calcule les charges pour les positions intermédiaires de la flèche

\* Main boom angle 88° · Hauptauslegerwinkel 88° · Jarret de flèche principale 88°



295 t + 60 t ZB		19-30 m		10,5 m		9.8 m/s		360°		ISO		
96 m + 48 m						96 m + 60 m						
		SWSL					SFSL					
		0 t		0 t - 640 t								
		85°	85°	75°	65°	55°	45°					
m	t	t	t	t	t	t	t	t	t			
24	-	277,0*	-	-	-	-	-	-	-			
26	-	270,0*	-	-	-	-	-	-	-			
28	-	263,0*	-	-	-	-	-	-	-			
30	163,0	290,0	-	-	-	-	-	-	281,0			
34	143,0	282,0	-	-	-	-	-	-	281,0			
38	127,0	270,0	-	-	-	-	-	-	281,0			
42	113,0	259,0	-	-	-	-	-	-	281,0			
46	101,0	248,0	-	-	-	-	-	-	281,0			
50	92,0	240,0	-	-	-	-	-	-	280,0			
54	83,5	231,0	292,0	-	-	-	-	-	272,0			
56	79,5	227,0	292,0	-	-	-	-	-	268,0			
58	-	-	291,0	-	-	-	-	-	264,0			
62	-	-	279,0	-	-	-	-	-	254,0			
66	-	-	272,0	-	-	-	-	-	245,0			
70	-	-	264,0	-	-	-	-	-	237,0			
74	-	-	245,0	-	-	-	-	-	225,0			
77	-	-	-	214,0	-	-	-	-	211,5			
78	-	-	-	211,0	-	-	-	-	207,0			
82	-	-	-	198,0	-	-	-	-	190,0			
86	-	-	-	187,0	-	-	-	-	174,0			
90	-	-	-	177,0	-	-	-	-	160,0			
94	-	-	-	-	-	-	-	-	147,0			
97	-	-	-	-	140,0	-	-	-	138,7			
98	-	-	-	-	139,0	-	-	-	136,0			
102	-	-	-	-	132,0	-	-	-	125,0			
104	-	-	-	-	129,0	-	-	-	120,0			
106	-	-	-	-	-	-	-	-	115,0			
110	-	-	-	-	-	-	-	-	106,0			
114	-	-	-	-	-	-	95,5	94,0				
117	-	-	-	-	-	-	92,0	85,0				
118	-	-	-	-	-	-	-	82,0				
122	-	-	-	-	-	-	-	70,5				
126	-	-	-	-	-	-	-	59,0				
130	-	-	-	-	-	-	-	51,0				
26	-	229,0*	-	-	-	-	-	-	-			
28	-	226,0*	-	-	-	-	-	-	-			
30	-	222,0*	-	-	-	-	-	-	-			
34	133,0	235,0	-	-	-	-	-	-	231,0			
38	117,0	232,0	-	-	-	-	-	-	231,0			
42	104,0	225,0	-	-	-	-	-	-	231,0			
46	93,5	217,0	-	-	-	-	-	-	231,0			
50	84,0	210,0	-	-	-	-	-	-	231,0			
54	76,0	202,0	-	-	-	-	-	-	231,0			
58	68,5	196,0	-	-	-	-	-	-	227,0			
60	65,5	193,0	237,0	-	-	-	-	-	224,0			
62	62,5	190,0	237,0	-	-	-	-	-	221,0			
66	56,5	184,0	235,0	-	-	-	-	-	216,0			
68	54,0	181,0	234,0	-	-	-	-	-	213,5			
70	-	-	231,0	-	-	-	-	-	211,0			
74	-	-	223,0	-	-	-	-	-	203,0			
78	-	-	219,0	-	-	-	-	-	198,0			
82	-	-	211,0	-	-	-	-	-	192,0			
84	-	-	202,0	-	-	-	-	-	186,5			
86	-	-	-	184,0	-	-	-	-	181,0			
90	-	-	-	174,0	-	-	-	-	166,0			
94	-	-	-	165,0	-	-	-	-	153,0			
98	-	-	-	156,0	-	-	-	-	141,0			
100	-	-	-	152,0	-	-	-	-	135,5			
102	-	-	-	-	-	-	-	-	130,0			
106	-	-	-	-	122,0	-	-	-	120,0			
110	-	-	-	-	116,0	-	-	-	111,0			
114	-	-	-	-	111,0	-	-	-	102,0			
116	-	-	-	-	108,0	-	-	-	98,2			
118	-	-	-	-	-	-	-	-	94,5			
122	-	-	-	-	-	-	-	-	84,5			
126	-	-	-	-	-	-	-	78,0	74,0			
128	-	-	-	-	-	-	-	76,0	68,7			
130	-	-	-	-	-	-	-	-	63,5			
134	-	-	-	-	-	-	-	-	53,5			
138	-	-	-	-	-	-	-	-	44,6			

6 m steps of luffing jib is standard · 6 m Stufung der Wippe ist Standard · Des paliers de 6 m sont de série pour la fléchette

Main boom angle 88°, 85°, 75°, 65°, 55° and 45°; capacities for intermediate boom positions are calculated by the crane control system IC-1  
Hauptauslegerwinkel 88°, 85°, 75°, 65°, 55° und 45°; Traglasten für Zwischenstellungen des Hauptauslegers werden von der Kransteuerung IC-1 berechnet

Jarret de flèche principale 88°, 85°, 75°, 65°, 55° et 45° ; le système de commande de la grue IC-1 calcule les charges pour les positions intermédiaires de la flèche

\* Main boom angle 88° · Hauptauslegerwinkel 88° · Jarret de flèche principale 88°

295 t + 60 t ZB		19-30 m		10,5 m		9.8 m/s		360°		ISO		
96 m + 72 m						96 m + 84 m						
		SWSL					SFSL					
		0 t		0 t - 640 t								
		85°	85°	75°	65°	55°	45°					
m	t	t	t	t	t	t	t	t	t			
30	-	187,0*	-	-	-	-	-	-	-			
34	-	182,0*	-	-	-	-	-	-	-			
38	-	176,0*	-	-	-	-	-	-	-			
40	102,0	192,0	-	-	-	-	-	-	189,0			
42	96,0	190,0	-	-	-	-	-	-	189,0			
46	85,5	185,0	-	-	-	-	-	-	189,0			
50	76,5	180,0	-	-	-	-	-	-	189,0			
54	68,5	175,0	-	-	-	-	-	-	189,0			
58	61,5	170,0	-	-	-	-	-	-	189,0			
62	55,5	165,0	-	-	-	-	-	-	187,0			
66	50,0	160,0	192,0	-	-	-	-	-	184,0			
70	45,3	156,0	192,0	-	-	-	-	-	181,0			
74	40,8	151,0	191,0	-	-	-	-	-	177,0			
78	36,8	146,0	189,0	-	-	-	-	-	174,0			
80	35,0	141,0	188,0	-	-	-	-	-	170,0			
82	-	-	186,0	-	-	-	-	-	168,0			
86	-	-	181,0	-	-	-	-	-	164,0			
90	-	-	178,0	-	-	-	-	-	161,0			
92	-	-	173,0	164,0	-	-	-	-	158,5			
94	-	-	166,0	160,0	-	-	-	-	156,0			
96	-	-	156,0	155,0	-	-	-	-	150,0			
98	-	-	-	151,0	-	-	-	-	144,0			
102	-	-	-	143,0	-	-	-	-	133,0			
106	-	-	-	136,0	-	-	-	-	122,0			
110	-	-	-	130,0	-	-	-	-	113,0			
112	-	-	-	127,0	-	-	-	-	108,5			
114	-	-	-	-	-	-	-	-	104,0			
116	-	-	-	-	102,0	-	-	-	100,2			
118	-	-	-	-	100,0	-	-	-	96,5			
122	-	-	-	-	95,0	-	-	-	88,5			
126	-	-	-	-	91,0	-	-	-	81,5			
130	-	-	-	-	-	-	-	-	72,5			
134	-	-	-	-	-	-	-	-	63,5			
136	-	-	-	-	-	-	62,0	-	59,0			
138	-	-	-	-	-	-	60,0	-	54,5			
140	-	-	-	-	-	-	58,5	-	50,1			
142	-	-	-	-	-	-	-	-	45,8			
146	-	-	-	-	-	-	-	-	37,2			
150	-	-	-	-	-	-	-	-	31,7			
34	-	151,0*	-	-	-	-	-	-	-			
38	-	148,0*	-	-	-	-	-	-	-			
42	-	144,0*	-	-	-	-	-	-	-			
44	80,0	156,0	-	-	-	-	-	-	154,0			
46	75,0	155,0	-	-	-	-	-	-	154,0			
50	66,5	151,0	-	-	-	-	-	-	154,0			
54	59,0	148,0	-	-	-	-	-	-	154,0			
58	52,5	144,0	-	-	-	-	-	-	154,0			
62	46,5	141,0	-	-	-	-	-	-	154,0			
66	41,3	137,0	-	-	-	-	-	-	153,0			
70	36,5	134,0	-	-	-	-	-	-	151,0			
72	34,3	132,0	154,0	-	-	-	-	-	150,0			
74	32,2	130,0	154,0	-	-	-	-	-	149,0			
78	28,3	127,0	154,0	-	-	-	-	-	147,0			
80	26,4	125,0	154,0	-	-	-	-	-	145,5			
82	24,7	123,0	154,0	-	-	-	-	-	144,0			
86	21,4	119,0	152,0	-	-	-	-	-	142,0			
90	18,4	110,5	151,0	-	-	-	-	-	137,0			
92	17,0	104,0	150,0	-	-	-	-	-	136,0			
94	-	-	147,0	-	-	-	-	-	135,0			
98	-	-	145,0	-	-	-	-	-	132,0			
100	-	-	141,0	127,0	-	-	-	-	131,0			
102	-	-	136,0	127,0	-	-	-	-	130,0			
106	-	-	125,0	126,0	-	-	-	-	120,0			
108	-	-	117,0	123,0	-	-	-	-	115,0			
110	-	-	-	120,0	-	-	-	-	110,0			
114	-	-	-	114,0	-	-	-	-	102,0			
118	-	-	-	109,0	-	-	-	-	93,5			
122	-	-	-	104,0	-	-	-	-	86,0			
124	-	-	-	101,0	-	-	-	-	82,5			
126	-	-	-	-	81,0	-	-	-	79,0			
130	-	-	-	-	77,0	-	-	-	72,0			
134	-	-	-	-	73,5	-	-	-	65,5			
138	-	-	-	-	70,5	-	-	-	57,0			
142	-	-	-	-	-	-	-	-	49,2			
146	-	-	-	-	-	-	-	43,7	41,3			
150	-	-	-	-	-	-	-	41,0	33,6			
154	-	-	-	-	-	-	-	-	26,0			
158	-	-	-	-	-	-	-	-	19,1			
162	-	-	-	-	-	-	-	-	14,9			

6 m steps of luffing jib is standard · 6 m Stufung der Wippe ist Standard · Des paliers de 6 m sont de série pour la fléchette

Main boom angle 88°, 85°, 75°, 65°, 55° and 45°; capacities for intermediate boom positions are calculated by the crane control system IC-1  
Hauptauslegerwinkel 88°, 85°, 75°, 65°, 55° und 45°; Traglasten für Zwischenstellungen des Hauptauslegers werden von der Kransteuerung IC-1 berechnet

Jarret de flèche principale 88°, 85°, 75°, 65°, 55° et 45° ; le système de commande de la grue IC-1 calcule les charges pour les positions intermédiaires de la flèche

\* Main boom angle 88° · Hauptauslegerwinkel 88° · Jarret de flèche principale 88°

295 t + 60 t ZB		19-30 m		10,5 m		9.8 m/s		360°		ISO		
96 m + 96 m						96 m + 108 m						
		SWSL					SFSL					
		0 t		0 t - 640 t								
		85°	85°	75°	65°	55°	45°					
m	t	t	t	t	t	t	t	t	t			
38	-	124,0*	-	-	-	-	-	-	-			
42	-	121,0*	-	-	-	-	-	-	-			
46	-	118,0*	-	-	-	-	-	-	-			
48	63,0	125,0	-	-	-	-	-	-	124,0			
50	59,0	125,0	-	-	-	-	-	-	124,0			
54	51,5	123,0	-	-	-	-	-	-	124,0			
58	45,3	120,0	-	-	-	-	-	-	124,0			
62	39,6	117,0	-	-	-	-	-	-	124,0			
66	34,5	115,0	-	-	-	-	-	-	124,0			
70	29,9	113,0	-	-	-	-	-	-	124,0			
74	25,7	110,0	-	-	-	-	-	-	123,0			
78	21,9	108,0	121,0	-	-	-	-	-	121,0			
82	18,5	105,5	121,0	-	-	-	-	-	118,0			
86	15,3	102,5	121,0	-	-	-	-	-	116,0			
90	12,4	99,5	121,0	-	-	-	-	-	114,0			
92	11,0	98,0	121,0	-	-	-	-	-	113,0			
94	-	96,5	120,0	-	-	-	-	-	112,0			
98	-	93,5	119,0	-	-	-	-	-	109,0			
100	-	92,0	119,0	-	-	-	-	-	107,5			
102	-	-	118,0	-	-	-	-	-	106,0			
106	-	-	118,0	-	-	-	-	-	103,0			
108	-	-	117,0	105,0	-	-	-	-	102,0			
110	-	-	114,0	105,0	-	-	-	-	101,0			
114	-	-	106,0	105,0	-	-	-	-	98,5			
118	-	-	96,5	104,0	-	-	-	-	95,0			
120	-	-	90,5	101,0	-	-	-	-	91,0			
122	-	-	-	99,0	-	-	-	-	87,0			
126	-	-	-	94,0	-	-	-	-	80,0			
130	-	-	-	89,5	-	-	-	-	73,0			
134	-	-	-	85,5	68,0	-	-	-	66,5			
138	-	-	-	-	64,5	-	-	-	60,5			
142	-	-	-	-	61,5	-	-	-	54,5			
146	-	-	-	-	58,5	-	-	-	47,2			
150	-	-	-	-	55,5	-	-	-	39,9			
154	-	-	-	-	-	-	-	-	32,8			
156	-	-	-	-	-	-	-	31,1	29,3			
158	-	-	-	-	-	-	-	29,9	25,8			
162	-	-	-	-	-	-	-	27,6	19,0			
166	-	-	-	-	-	-	-	-	12,3			
42	-	99,0*	-	-	-	-	-	-	-			
46	-	97,0*	-	-	-	-	-	-	-			
50	-	95,0*	-	-	-	-	-	-	-			
52	47,8	100,0	-	-	-	-	-	-	-			
54	44,5	100,0	-	-	-	-	-	-	100,0			
58	38,3	98,5	-	-	-	-	-	-	100,0			
62	32,8	97,0	-	-	-	-	-	-	99,5			
66	27,9	95,0	-	-	-	-	-	-	99,0			
68	25,6	94,0	-	-	-	-	-	-	98,7			
70	23,4	93,0	-	-	-	-	-	-	98,5			
74	19,4	91,5	-	-	-	-	-	-	98,0			
78	15,7	89,5	-	-	-	-	-	-	97,5			
82	12,4	87,7	-	-	-	-	-	-	96,0			
84	10,8	87,0	95,0	-	-	-	-	-	95,2			
86	-	86,0	95,0	-	-	-	-	-	94,5			
90	-	83,5	95,0	-	-	-	-	-	93,0			
94	-	80,5	95,0	-	-	-	-	-	91,5			
98	-	77,2	95,0	-	-	-	-	-	90,0			
102	-	74,0	94,5	-	-	-	-	-	88,5			
106	-	71,0	94,5	-	-	-	-	-	87,0			
110	-	67,7	94,0	-	-	-	-	-	85,5			
112	-	66,0	94,0	-	-	-	-	-	83,0			
114	-	-	93,5	-	-	-	-	-	82,0			
116	-	-	92,5	81,5	-	-	-	-	81,2			
118	-	-	91,0	81,5	-	-	-	-	80,5			
122	-	-	87,0	81,5	-	-	-	-	79,0			
126	-	-	80,5	81,5	-	-	-	-	77,5			
130	-	-	72,0	81,5	-	-	-	-	72,0			
134	-	-	-	79,0	-	-	-	-	65,5			
138	-	-	-	75,0	-	-	-	-	59,5			
142	-	-	-	71,5	-	-	-	-	54,0			
144	-	-	-	69,5	53,5	-	-	-	51,6			
146	-	-	-	68,0	52,0	-	-	-	49,2			
150	-	-	-	-	49,8	-	-	-	42,3			
154	-	-	-	-	46,8	-	-	-	35,6			
158	-	-	-	-	43,9	-	-	-	29,0			
160	-	-	-	-	42,6	-	-	-	25,8			
162	-	-	-	-	-	-	-	-	22,7			
166	-	-	-	-	-	-	-	17,8	16,5			
170	-	-	-	-	-	-	-	15,8	10,5			
174	-	-	-	-	-	-	-	14,0	-			

6 m steps of luffing jib is standard · 6 m Stufung der Wippe ist Standard · Des paliers de 6 m sont de série pour la fléchette

Main boom angle 88°, 85°, 75°, 65°, 55° and 45°; capacities for intermediate boom positions are calculated by the crane control system IC-1  
Hauptauslegerwinkel 88°, 85°, 75°, 65°, 55° und 45°; Traglasten für Zwischenstellungen des Hauptauslegers werden von der Kransteuerung IC-1 berechnet

Jarret de flèche principale 88°, 85°, 75°, 65°, 55° et 45° ; le système de commande de la grue IC-1 calcule les charges pour les positions intermédiaires de la flèche

\* Main boom angle 88° · Hauptauslegerwinkel 88° · Jarret de flèche principale 88°

295 t + 60 t ZB		19-30 m		10,5 m		9.8 m/s		360°		ISO		
102 m + 36 m						102 m + 48 m						
		SWSL					SFSL					
		0 t		0 t - 640 t								
		85°	85°	75°	65°	55°	45°					
m	t	t	t	t	t	t	t	t	t			
20	-	312,0*	-	-	-	-	-	-	-			
22	-	304,0*	-	-	-	-	-	-	-			
24	-	295,0*	-	-	-	-	-	-	-			
26	-	287,0*	-	-	-	-	-	-	-			
28	180,0	321,0	-	-	-	-	-	-	314,0			
30	168,0	314,0	-	-	-	-	-	-	314,0			
34	148,0	298,0	-	-	-	-	-	-	314,0			
38	131,0	284,0	-	-	-	-	-	-	314,0			
42	118,0	273,0	-	-	-	-	-	-	314,0			
46	106,0	263,0	-	-	-	-	-	-	312,0			
50	-	-	322,0	-	-	-	-	-	303,0			
54	-	-	316,0	-	-	-	-	-	293,0			
58	-	-	303,0	-	-	-	-	-	280,0			
62	-	-	294,0	-	-	-	-	-	271,0			
64	-	-	290,0	-	-	-	-	-	266,5			
66	-	-	-	-	-	-	-	-	262,0			
70	-	-	-	-	-	-	-	-	238,0			
72	-	-	-	231,0	-	-	-	-	227,5			
74	-	-	-	223,0	-	-	-	-	217,0			
78	-	-	-	210,0	-	-	-	-	198,0			
80	-	-	-	203,0	-	-	-	-	190,0			
82	-	-	-	-	-	-	-	-	182,0			
86	-	-	-	-	-	-	-	-	166,0			
90	-	-	-	-	-	-	-	-	153,0			
91	-	-	-	-	151,0	-	-	-	149,7			
94	-	-	-	-	145,0	-	-	-	140,0			
96	-	-	-	-	142,0	-	-	-	134,5			
98	-	-	-	-	-	-	-	-	129,0			
102	-	-	-	-	-	-	-	-	118,0			
106	-	-	-	-	-	-	-	-	108,0			
108	-	-	-	-	-	-	-	104,0	101,7			
110	-	-	-	-	-	-	-	101,0	95,5			
114	-	-	-	-	-	-	-	-	83,0			
118	-	-	-	-	-	-	-	-	70,5			
122	-	-	-	-	-	-	-	-	58,5			
24	-	253,0*	-	-	-	-	-	-	-			
26	-	247,0*	-	-	-	-	-	-	-			
28	-	241,0*	-	-	-	-	-	-	-			
30	-	235,0*	-	-	-	-	-	-	-			
32	145,0	262,0	-	-	-	-	-	-	256,0			
34	136,0	257,0	-	-	-	-	-	-	256,0			
38	121,0	247,0	-	-	-	-	-	-	256,0			
42	108,0	237,0	-	-	-	-	-	-	256,0			
46	97,0	227,0	-	-	-	-	-	-	256,0			
50	87,5	219,0	-	-	-	-	-	-	256,0			
54	79,0	211,0	-	-	-	-	-	-	250,0			
56	75,5	208,0	262,0	-	-	-	-	-	247,0			
58	72,0	204,0	262,0	-	-	-	-	-	244,0			
62	-	-	258,0	-	-	-	-	-	237,0			
66	-	-	245,0	-	-	-	-	-	227,0			
70	-	-	239,0	-	-	-	-	-	221,0			
74	-	-	234,0	-	-	-	-	-	214,0			
76	-	-	231,0	-	-	-	-	-	208,0			
78	-	-	-	-	-	-	-	-	202,0			
79	-	-	-	200,0	-	-	-	-	197,7			
82	-	-	-	191,0	-	-	-	-	185,0			
86	-	-	-	180,0	-	-	-	-	170,0			
90	-	-	-	170,0	-	-	-	-	156,0			
92	-	-	-	166,0	-	-	-	-	149,5			
94	-	-	-	-	-	-	-	-	143,0			
98	-	-	-	-	-	-	-	-	131,0			
100	-	-	-	-	-	127,0	-	-	126,0			
102	-	-	-	-	-	124,0	-	-	121,0			
106	-	-	-	-	-	118,0	-	-	111,0			
108	-	-	-	-	-	115,0	-	-	106,5			
110	-	-	-	-	-	-	-	-	102,0			
114	-	-	-	-	-	-	-	-	93,5			
118	-	-	-	-	-	-	-	-	82,5			
119	-	-	-	-	-	-	-	83,0	79,7			
120	-	-	-	-	-	-	-	81,5	77,0			
122	-	-	-	-	-	-	-	-	71,5			
126	-	-	-	-	-	-	-	-	61,0			
130	-	-	-	-	-	-	-	-	50,5			
134	-	-	-	-	-	-	-	-	42,7			

6 m steps of luffing jib is standard · 6 m Stufung der Wippe ist Standard · Des paliers de 6 m sont de série pour la fléchette

Main boom angle 88°, 85°, 75°, 65°, 55° and 45°; capacities for intermediate boom positions are calculated by the crane control system IC-1  
Hauptauslegerwinkel 88°, 85°, 75°, 65°, 55° und 45°; Traglasten für Zwischenstellungen des Hauptauslegers werden von der Kransteuerung IC-1 berechnet

Jarret de flèche principale 88°, 85°, 75°, 65°, 55° et 45° ; le système de commande de la grue IC-1 calcule les charges pour les positions intermédiaires de la flèche

\* Main boom angle 88° · Hauptauslegerwinkel 88° · Jarret de flèche principale 88°

295 t + 60 t ZB		19-30 m		10,5 m		9.8 m/s		360°		ISO							
102 m + 60 m						102 m + 72 m											
		SWSL					SFSL				SWSL		SFSL				
		0 t		0 t - 640 t							0 t		0 t - 640 t				
		85°	85°	75°	65°	55°	45°			85°	85°	75°	65°	55°	45°		
m	t	t	t	t	t	t	t	t	m	t	t	t	t	t	t		
28	-	207,0*	-	-	-	-	-	-	30	-	171,0*	-	-	-	-		
30	-	203,0*	-	-	-	-	-	-	34	-	167,0*	-	-	-	-		
34	-	194,0*	-	-	-	-	-	-	38	-	160,0*	-	-	-	-		
36	118,0	215,0	-	-	-	-	-	211,0	40	96,5	176,0	-	-	-	173,0		
38	111,0	212,0	-	-	-	-	-	211,0	42	91,0	174,0	-	-	-	173,0		
42	99,5	205,0	-	-	-	-	-	211,0	46	80,5	169,0	-	-	-	173,0		
46	89,0	198,0	-	-	-	-	-	211,0	50	72,0	164,0	-	-	-	173,0		
50	79,5	191,0	-	-	-	-	-	211,0	54	64,5	159,0	-	-	-	173,0		
54	72,0	184,0	-	-	-	-	-	211,0	58	58,0	154,0	-	-	-	173,0		
58	65,0	178,0	-	-	-	-	-	208,0	62	52,0	150,0	-	-	-	172,0		
62	59,0	173,0	213,0	-	-	-	-	204,0	66	46,9	145,0	-	-	-	170,0		
66	53,5	167,0	213,0	-	-	-	-	200,0	68	44,4	143,0	173,0	-	-	168,5		
68	51,0	165,0	212,0	-	-	-	-	197,5	70	42,1	141,0	173,0	-	-	167,0		
70	-	-	210,0	-	-	-	-	195,0	74	37,8	137,0	172,0	-	-	164,0		
74	-	-	206,0	-	-	-	-	191,0	78	33,9	133,0	171,0	-	-	161,0		
78	-	-	198,0	-	-	-	-	183,0	80	32,1	131,0	169,0	-	-	159,5		
82	-	-	194,0	-	-	-	-	179,0	82	-	-	168,0	-	-	158,0		
86	-	-	189,0	-	-	-	-	174,0	86	-	-	166,0	-	-	152,0		
88	-	-	-	173,0	-	-	-	168,0	90	-	-	161,0	-	-	149,0		
90	-	-	-	168,0	-	-	-	162,0	94	-	-	157,0	-	-	145,0		
94	-	-	-	159,0	-	-	-	149,0	96	-	-	156,0	149,0	-	142,5		
98	-	-	-	150,0	-	-	-	137,0	98	-	-	154,0	145,0	-	140,0		
102	-	-	-	143,0	-	-	-	127,0	102	-	-	-	138,0	-	129,0		
104	-	-	-	139,0	-	-	-	121,5	106	-	-	-	131,0	-	119,0		
106	-	-	-	-	-	-	-	116,0	110	-	-	-	124,0	-	109,0		
110	-	-	-	-	109,0	-	-	107,0	114	-	-	-	118,0	-	100,0		
114	-	-	-	-	104,0	-	-	98,5	118	-	-	-	-	-	92,5		
118	-	-	-	-	99,0	-	-	90,5	120	-	-	-	-	91,0	88,7		
122	-	-	-	-	-	-	-	83,0	122	-	-	-	-	88,5	85,0		
126	-	-	-	-	-	-	-	74,0	126	-	-	-	-	84,5	77,5		
130	-	-	-	-	-	-	68,0	64,0	130	-	-	-	-	81,0	71,0		
132	-	-	-	-	-	-	66,0	59,2	134	-	-	-	-	-	62,5		
134	-	-	-	-	-	-	-	54,5	138	-	-	-	-	-	54,0		
138	-	-	-	-	-	-	-	45,5	140	-	-	-	-	-	53,0		
142	-	-	-	-	-	-	-	36,4	142	-	-	-	-	-	51,5		
146	-	-	-	-	-	-	-	31,1	144	-	-	-	-	-	50,0		
									146	-	-	-	-	-	41,9		
									150	-	-	-	-	-	29,7		
									154	-	-	-	-	-	22,6		

6 m steps of luffing jib is standard · 6 m Stufung der Wippe ist Standard · Des paliers de 6 m sont de série pour la fléchette

Main boom angle 88°, 85°, 75°, 65°, 55° and 45°; capacities for intermediate boom positions are calculated by the crane control system IC-1  
 Hauptauslegerwinkel 88°, 85°, 75°, 65°, 55° und 45°; Traglasten für Zwischenstellungen des Hauptauslegers werden von der Kransteuerung IC-1 berechnet

Jarret de flèche principale 88°, 85°, 75°, 65°, 55° et 45° ; le système de commande de la grue IC-1 calcule les charges pour les positions intermédiaires de la flèche

\* Main boom angle 88° · Hauptauslegerwinkel 88° · Jarret de flèche principale 88°

295 t + 60 t ZB		19-30 m		10,5 m		9.8 m/s		360°		ISO																																																																																																																																																																																																																																																																																																																																																																																																																																																																																																																									
102 m + 84 m						102 m + 96 m																																																																																																																																																																																																																																																																																																																																																																																																																																																																																																																													
<table border="1"> <thead> <tr> <th colspan="11">SWSL</th> <th>SFSL</th> </tr> <tr> <th colspan="12">0 t - 640 t</th> </tr> <tr> <th></th> <th>85°</th> <th>85°</th> <th>75°</th> <th>65°</th> <th>55°</th> <th>45°</th> <th></th> <th></th> <th></th> <th></th> <th></th> </tr> <tr> <th>m</th> <th>t</th> <th>t</th> <th>t</th> <th>t</th> <th>t</th> <th>t</th> <th>t</th> <th>t</th> <th>t</th> <th>t</th> <th>t</th> </tr> </thead> <tbody> <tr><td>34</td><td>-</td><td>139,0*</td><td>-</td><td>-</td><td>-</td><td>-</td><td>-</td><td>-</td><td>-</td><td>-</td><td>-</td></tr> <tr><td>38</td><td>-</td><td>136,0*</td><td>-</td><td>-</td><td>-</td><td>-</td><td>-</td><td>-</td><td>-</td><td>-</td><td>-</td></tr> <tr><td>42</td><td>-</td><td>132,0*</td><td>-</td><td>-</td><td>-</td><td>-</td><td>-</td><td>-</td><td>-</td><td>-</td><td>-</td></tr> <tr><td>44</td><td>75,0</td><td>142,0</td><td>-</td><td>-</td><td>-</td><td>-</td><td>-</td><td>-</td><td>-</td><td>140,0</td><td>-</td></tr> <tr><td>46</td><td>70,5</td><td>141,0</td><td>-</td><td>-</td><td>-</td><td>-</td><td>-</td><td>-</td><td>-</td><td>140,0</td><td>-</td></tr> <tr><td>50</td><td>62,0</td><td>138,0</td><td>-</td><td>-</td><td>-</td><td>-</td><td>-</td><td>-</td><td>-</td><td>140,0</td><td>-</td></tr> <tr><td>54</td><td>55,0</td><td>134,0</td><td>-</td><td>-</td><td>-</td><td>-</td><td>-</td><td>-</td><td>-</td><td>140,0</td><td>-</td></tr> <tr><td>58</td><td>48,6</td><td>131,0</td><td>-</td><td>-</td><td>-</td><td>-</td><td>-</td><td>-</td><td>-</td><td>140,0</td><td>-</td></tr> <tr><td>62</td><td>43,0</td><td>127,0</td><td>-</td><td>-</td><td>-</td><td>-</td><td>-</td><td>-</td><td>-</td><td>140,0</td><td>-</td></tr> <tr><td>66</td><td>37,9</td><td>124,0</td><td>-</td><td>-</td><td>-</td><td>-</td><td>-</td><td>-</td><td>-</td><td>140,0</td><td>-</td></tr> <tr><td>70</td><td>33,3</td><td>120,0</td><td>-</td><td>-</td><td>-</td><td>-</td><td>-</td><td>-</td><td>-</td><td>138,0</td><td>-</td></tr> <tr><td>74</td><td>29,2</td><td>117,0</td><td>137,0</td><td>-</td><td>-</td><td>-</td><td>-</td><td>-</td><td>-</td><td>135,0</td><td>-</td></tr> <tr><td>78</td><td>25,4</td><td>114,0</td><td>137,0</td><td>-</td><td>-</td><td>-</td><td>-</td><td>-</td><td>-</td><td>132,0</td><td>-</td></tr> <tr><td>80</td><td>23,7</td><td>113,0</td><td>137,0</td><td>-</td><td>-</td><td>-</td><td>-</td><td>-</td><td>-</td><td>130,5</td><td>-</td></tr> <tr><td>82</td><td>22,0</td><td>111,5</td><td>136,0</td><td>-</td><td>-</td><td>-</td><td>-</td><td>-</td><td>-</td><td>129,0</td><td>-</td></tr> <tr><td>86</td><td>18,9</td><td>108,5</td><td>135,0</td><td>-</td><td>-</td><td>-</td><td>-</td><td>-</td><td>-</td><td>126,0</td><td>-</td></tr> <tr><td>90</td><td>16,0</td><td>105,5</td><td>133,0</td><td>-</td><td>-</td><td>-</td><td>-</td><td>-</td><td>-</td><td>124,0</td><td>-</td></tr> <tr><td>92</td><td>14,6</td><td>104,0</td><td>132,0</td><td>-</td><td>-</td><td>-</td><td>-</td><td>-</td><td>-</td><td>122,5</td><td>-</td></tr> <tr><td>94</td><td>-</td><td>-</td><td>131,0</td><td>-</td><td>-</td><td>-</td><td>-</td><td>-</td><td>-</td><td>121,0</td><td>-</td></tr> <tr><td>98</td><td>-</td><td>-</td><td>130,0</td><td>-</td><td>-</td><td>-</td><td>-</td><td>-</td><td>-</td><td>116,0</td><td>-</td></tr> <tr><td>102</td><td>-</td><td>-</td><td>128,0</td><td>116,0</td><td>-</td><td>-</td><td>-</td><td>-</td><td>-</td><td>113,0</td><td>-</td></tr> <tr><td>106</td><td>-</td><td>-</td><td>123,0</td><td>116,0</td><td>-</td><td>-</td><td>-</td><td>-</td><td>-</td><td>110,0</td><td>-</td></tr> <tr><td>110</td><td>-</td><td>-</td><td>115,0</td><td>115,0</td><td>-</td><td>-</td><td>-</td><td>-</td><td>-</td><td>107,0</td><td>-</td></tr> <tr><td>114</td><td>-</td><td>-</td><td>-</td><td>109,0</td><td>-</td><td>-</td><td>-</td><td>-</td><td>-</td><td>98,0</td><td>-</td></tr> <tr><td>118</td><td>-</td><td>-</td><td>-</td><td>104,0</td><td>-</td><td>-</td><td>-</td><td>-</td><td>-</td><td>90,0</td><td>-</td></tr> <tr><td>122</td><td>-</td><td>-</td><td>-</td><td>99,0</td><td>-</td><td>-</td><td>-</td><td>-</td><td>-</td><td>82,0</td><td>-</td></tr> <tr><td>126</td><td>-</td><td>-</td><td>-</td><td>94,5</td><td>-</td><td>-</td><td>-</td><td>-</td><td>-</td><td>75,0</td><td>-</td></tr> <tr><td>128</td><td>-</td><td>-</td><td>-</td><td>-</td><td>73,0</td><td>-</td><td>-</td><td>-</td><td>-</td><td>71,5</td><td>-</td></tr> <tr><td>130</td><td>-</td><td>-</td><td>-</td><td>-</td><td>71,0</td><td>-</td><td>-</td><td>-</td><td>-</td><td>68,0</td><td>-</td></tr> <tr><td>134</td><td>-</td><td>-</td><td>-</td><td>-</td><td>67,5</td><td>-</td><td>-</td><td>-</td><td>-</td><td>62,0</td><td>-</td></tr> <tr><td>138</td><td>-</td><td>-</td><td>-</td><td>-</td><td>64,0</td><td>-</td><td>-</td><td>-</td><td>-</td><td>55,5</td><td>-</td></tr> <tr><td>142</td><td>-</td><td>-</td><td>-</td><td>-</td><td>61,5</td><td>-</td><td>-</td><td>-</td><td>-</td><td>48,0</td><td>-</td></tr> <tr><td>146</td><td>-</td><td>-</td><td>-</td><td>-</td><td>-</td><td>-</td><td>-</td><td>-</td><td>-</td><td>40,4</td><td>-</td></tr> <tr><td>150</td><td>-</td><td>-</td><td>-</td><td>-</td><td>-</td><td>35,3</td><td>33,0</td><td>-</td><td>-</td><td>-</td><td>-</td></tr> <tr><td>154</td><td>-</td><td>-</td><td>-</td><td>-</td><td>-</td><td>32,9</td><td>25,8</td><td>-</td><td>-</td><td>-</td><td>-</td></tr> <tr><td>156</td><td>-</td><td>-</td><td>-</td><td>-</td><td>-</td><td>31,8</td><td>22,2</td><td>-</td><td>-</td><td>-</td><td>-</td></tr> <tr><td>158</td><td>-</td><td>-</td><td>-</td><td>-</td><td>-</td><td>-</td><td>18,7</td><td>-</td><td>-</td><td>-</td><td>-</td></tr> <tr><td>162</td><td>-</td><td>-</td><td>-</td><td>-</td><td>-</td><td>-</td><td>11,7</td><td>-</td><td>-</td><td>-</td><td>-</td></tr> </tbody> </table>												SWSL											SFSL	0 t - 640 t													85°	85°	75°	65°	55°	45°						m	t	t	t	t	t	t	t	t	t	t	t	34	-	139,0*	-	-	-	-	-	-	-	-	-	38	-	136,0*	-	-	-	-	-	-	-	-	-	42	-	132,0*	-	-	-	-	-	-	-	-	-	44	75,0	142,0	-	-	-	-	-	-	-	140,0	-	46	70,5	141,0	-	-	-	-	-	-	-	140,0	-	50	62,0	138,0	-	-	-	-	-	-	-	140,0	-	54	55,0	134,0	-	-	-	-	-	-	-	140,0	-	58	48,6	131,0	-	-	-	-	-	-	-	140,0	-	62	43,0	127,0	-	-	-	-	-	-	-	140,0	-	66	37,9	124,0	-	-	-	-	-	-	-	140,0	-	70	33,3	120,0	-	-	-	-	-	-	-	138,0	-	74	29,2	117,0	137,0	-	-	-	-	-	-	135,0	-	78	25,4	114,0	137,0	-	-	-	-	-	-	132,0	-	80	23,7	113,0	137,0	-	-	-	-	-	-	130,5	-	82	22,0	111,5	136,0	-	-	-	-	-	-	129,0	-	86	18,9	108,5	135,0	-	-	-	-	-	-	126,0	-	90	16,0	105,5	133,0	-	-	-	-	-	-	124,0	-	92	14,6	104,0	132,0	-	-	-	-	-	-	122,5	-	94	-	-	131,0	-	-	-	-	-	-	121,0	-	98	-	-	130,0	-	-	-	-	-	-	116,0	-	102	-	-	128,0	116,0	-	-	-	-	-	113,0	-	106	-	-	123,0	116,0	-	-	-	-	-	110,0	-	110	-	-	115,0	115,0	-	-	-	-	-	107,0	-	114	-	-	-	109,0	-	-	-	-	-	98,0	-	118	-	-	-	104,0	-	-	-	-	-	90,0	-	122	-	-	-	99,0	-	-	-	-	-	82,0	-	126	-	-	-	94,5	-	-	-	-	-	75,0	-	128	-	-	-	-	73,0	-	-	-	-	71,5	-	130	-	-	-	-	71,0	-	-	-	-	68,0	-	134	-	-	-	-	67,5	-	-	-	-	62,0	-	138	-	-	-	-	64,0	-	-	-	-	55,5	-	142	-	-	-	-	61,5	-	-	-	-	48,0	-	146	-	-	-	-	-	-	-	-	-	40,4	-	150	-	-	-	-	-	35,3	33,0	-	-	-	-	154	-	-	-	-	-	32,9	25,8	-	-	-	-	156	-	-	-	-	-	31,8	22,2	-	-	-	-	158	-	-	-	-	-	-	18,7	-	-	-	-	162	-	-	-	-	-	-	11,7	-	-	-	-
SWSL											SFSL																																																																																																																																																																																																																																																																																																																																																																																																																																																																																																																								
0 t - 640 t																																																																																																																																																																																																																																																																																																																																																																																																																																																																																																																																			
	85°	85°	75°	65°	55°	45°																																																																																																																																																																																																																																																																																																																																																																																																																																																																																																																													
m	t	t	t	t	t	t	t	t	t	t	t																																																																																																																																																																																																																																																																																																																																																																																																																																																																																																																								
34	-	139,0*	-	-	-	-	-	-	-	-	-																																																																																																																																																																																																																																																																																																																																																																																																																																																																																																																								
38	-	136,0*	-	-	-	-	-	-	-	-	-																																																																																																																																																																																																																																																																																																																																																																																																																																																																																																																								
42	-	132,0*	-	-	-	-	-	-	-	-	-																																																																																																																																																																																																																																																																																																																																																																																																																																																																																																																								
44	75,0	142,0	-	-	-	-	-	-	-	140,0	-																																																																																																																																																																																																																																																																																																																																																																																																																																																																																																																								
46	70,5	141,0	-	-	-	-	-	-	-	140,0	-																																																																																																																																																																																																																																																																																																																																																																																																																																																																																																																								
50	62,0	138,0	-	-	-	-	-	-	-	140,0	-																																																																																																																																																																																																																																																																																																																																																																																																																																																																																																																								
54	55,0	134,0	-	-	-	-	-	-	-	140,0	-																																																																																																																																																																																																																																																																																																																																																																																																																																																																																																																								
58	48,6	131,0	-	-	-	-	-	-	-	140,0	-																																																																																																																																																																																																																																																																																																																																																																																																																																																																																																																								
62	43,0	127,0	-	-	-	-	-	-	-	140,0	-																																																																																																																																																																																																																																																																																																																																																																																																																																																																																																																								
66	37,9	124,0	-	-	-	-	-	-	-	140,0	-																																																																																																																																																																																																																																																																																																																																																																																																																																																																																																																								
70	33,3	120,0	-	-	-	-	-	-	-	138,0	-																																																																																																																																																																																																																																																																																																																																																																																																																																																																																																																								
74	29,2	117,0	137,0	-	-	-	-	-	-	135,0	-																																																																																																																																																																																																																																																																																																																																																																																																																																																																																																																								
78	25,4	114,0	137,0	-	-	-	-	-	-	132,0	-																																																																																																																																																																																																																																																																																																																																																																																																																																																																																																																								
80	23,7	113,0	137,0	-	-	-	-	-	-	130,5	-																																																																																																																																																																																																																																																																																																																																																																																																																																																																																																																								
82	22,0	111,5	136,0	-	-	-	-	-	-	129,0	-																																																																																																																																																																																																																																																																																																																																																																																																																																																																																																																								
86	18,9	108,5	135,0	-	-	-	-	-	-	126,0	-																																																																																																																																																																																																																																																																																																																																																																																																																																																																																																																								
90	16,0	105,5	133,0	-	-	-	-	-	-	124,0	-																																																																																																																																																																																																																																																																																																																																																																																																																																																																																																																								
92	14,6	104,0	132,0	-	-	-	-	-	-	122,5	-																																																																																																																																																																																																																																																																																																																																																																																																																																																																																																																								
94	-	-	131,0	-	-	-	-	-	-	121,0	-																																																																																																																																																																																																																																																																																																																																																																																																																																																																																																																								
98	-	-	130,0	-	-	-	-	-	-	116,0	-																																																																																																																																																																																																																																																																																																																																																																																																																																																																																																																								
102	-	-	128,0	116,0	-	-	-	-	-	113,0	-																																																																																																																																																																																																																																																																																																																																																																																																																																																																																																																								
106	-	-	123,0	116,0	-	-	-	-	-	110,0	-																																																																																																																																																																																																																																																																																																																																																																																																																																																																																																																								
110	-	-	115,0	115,0	-	-	-	-	-	107,0	-																																																																																																																																																																																																																																																																																																																																																																																																																																																																																																																								
114	-	-	-	109,0	-	-	-	-	-	98,0	-																																																																																																																																																																																																																																																																																																																																																																																																																																																																																																																								
118	-	-	-	104,0	-	-	-	-	-	90,0	-																																																																																																																																																																																																																																																																																																																																																																																																																																																																																																																								
122	-	-	-	99,0	-	-	-	-	-	82,0	-																																																																																																																																																																																																																																																																																																																																																																																																																																																																																																																								
126	-	-	-	94,5	-	-	-	-	-	75,0	-																																																																																																																																																																																																																																																																																																																																																																																																																																																																																																																								
128	-	-	-	-	73,0	-	-	-	-	71,5	-																																																																																																																																																																																																																																																																																																																																																																																																																																																																																																																								
130	-	-	-	-	71,0	-	-	-	-	68,0	-																																																																																																																																																																																																																																																																																																																																																																																																																																																																																																																								
134	-	-	-	-	67,5	-	-	-	-	62,0	-																																																																																																																																																																																																																																																																																																																																																																																																																																																																																																																								
138	-	-	-	-	64,0	-	-	-	-	55,5	-																																																																																																																																																																																																																																																																																																																																																																																																																																																																																																																								
142	-	-	-	-	61,5	-	-	-	-	48,0	-																																																																																																																																																																																																																																																																																																																																																																																																																																																																																																																								
146	-	-	-	-	-	-	-	-	-	40,4	-																																																																																																																																																																																																																																																																																																																																																																																																																																																																																																																								
150	-	-	-	-	-	35,3	33,0	-	-	-	-																																																																																																																																																																																																																																																																																																																																																																																																																																																																																																																								
154	-	-	-	-	-	32,9	25,8	-	-	-	-																																																																																																																																																																																																																																																																																																																																																																																																																																																																																																																								
156	-	-	-	-	-	31,8	22,2	-	-	-	-																																																																																																																																																																																																																																																																																																																																																																																																																																																																																																																								
158	-	-	-	-	-	-	18,7	-	-	-	-																																																																																																																																																																																																																																																																																																																																																																																																																																																																																																																								
162	-	-	-	-	-	-	11,7	-	-	-	-																																																																																																																																																																																																																																																																																																																																																																																																																																																																																																																								

6 m steps of luffing jib is standard · 6 m Stufung der Wippe ist Standard · Des paliers de 6 m sont de série pour la fléchette

Main boom angle 88°, 85°, 75°, 65°, 55° and 45°; capacities for intermediate boom positions are calculated by the crane control system IC-1  
 Hauptauslegerwinkel 88°, 85°, 75°, 65°, 55° und 45°; Traglasten für Zwischenstellungen des Hauptauslegers werden von der Kransteuerung IC-1 berechnet

Jarret de flèche principale 88°, 85°, 75°, 65°, 55° et 45° ; le système de commande de la grue IC-1 calcule les charges pour les positions intermédiaires de la flèche

\* Main boom angle 88° · Hauptauslegerwinkel 88° · Jarret de flèche principale 88°

295 t + 60 t ZB		19-30 m		10,5 m		9.8 m/s		360°		ISO	
102 m + 108 m						108 m + 36 m					
		SWSL						SFSL			
		0 t		0 t - 640 t							
		85°	85°	75°	65°	55°	45°				
m	t	t	t	t	t	t	t	t	t		
42	-	90,5*	-	-	-	-	-	-	-		
46	-	88,5*	-	-	-	-	-	-	-		
50	-	86,5*	-	-	-	-	-	-	-		
52	43,6	91,5	-	-	-	-	-	-	-		
54	40,4	91,5	-	-	-	-	-	-	91,0		
58	34,4	89,5	-	-	-	-	-	-	91,0		
62	29,2	88,0	-	-	-	-	-	-	91,0		
64	26,8	87,0	-	-	-	-	-	-	90,7		
66	24,5	86,0	-	-	-	-	-	-	90,5		
70	20,3	84,5	-	-	-	-	-	-	90,0		
74	16,4	82,5	-	-	-	-	-	-	89,5		
78	12,8	80,5	-	-	-	-	-	-	88,5		
80	11,2	80,0	-	-	-	-	-	-	88,0		
82	-	79,0	-	-	-	-	-	-	87,5		
86	-	77,0	85,5	-	-	-	-	-	86,0		
90	-	75,0	85,5	-	-	-	-	-	84,5		
94	-	73,0	85,5	-	-	-	-	-	83,0		
98	-	70,7	85,5	-	-	-	-	-	82,0		
102	-	68,5	85,5	-	-	-	-	-	80,5		
106	-	66,5	84,5	-	-	-	-	-	79,0		
110	-	64,2	84,0	-	-	-	-	-	77,5		
112	-	63,0	83,5	-	-	-	-	-	76,5		
114	-	-	83,5	-	-	-	-	-	75,5		
118	-	-	82,5	72,5	-	-	-	-	73,0		
122	-	-	81,5	72,5	-	-	-	-	72,0		
126	-	-	80,0	72,5	-	-	-	-	70,5		
130	-	-	76,0	72,5	-	-	-	-	68,5		
132	-	-	71,0	72,5	-	-	-	-	65,2		
134	-	-	-	72,5	-	-	-	-	62,0		
138	-	-	-	70,5	-	-	-	-	56,0		
142	-	-	-	67,0	-	-	-	-	51,5		
146	-	-	-	63,5	47,9	-	-	-	46,9		
148	-	-	-	62,0	46,3	-	-	-	43,5		
150	-	-	-	-	44,7	-	-	-	40,2		
154	-	-	-	-	41,7	-	-	-	33,6		
158	-	-	-	-	38,9	-	-	-	27,3		
162	-	-	-	-	36,3	-	-	-	21,2		
164	-	-	-	-	35,1	-	-	-	18,2		
166	-	-	-	-	-	-	-	-	15,2		

		0 t		0 t - 640 t							
		85°	85°	75°	65°	55°	45°				
m	t	t	t	t	t	t	t	t	t		
20	-	283,0*	-	-	-	-	-	-	-		
22	-	276,0*	-	-	-	-	-	-	-		
24	-	269,0*	-	-	-	-	-	-	-		
26	-	262,0*	-	-	-	-	-	-	-		
28	171,0	291,0	-	-	-	-	-	-	285,0		
30	159,0	285,0	-	-	-	-	-	-	285,0		
34	140,0	272,0	-	-	-	-	-	-	285,0		
38	125,0	260,0	-	-	-	-	-	-	285,0		
42	112,0	249,0	-	-	-	-	-	-	285,0		
46	101,0	240,0	-	-	-	-	-	-	285,0		
50	-	-	-	-	-	-	-	-	276,0		
52	-	-	288,0	-	-	-	-	-	272,0		
54	-	-	288,0	-	-	-	-	-	268,0		
58	-	-	280,0	-	-	-	-	-	260,0		
62	-	-	266,0	-	-	-	-	-	249,0		
66	-	-	259,0	-	-	-	-	-	240,0		
70	-	-	-	-	-	-	-	-	232,0		
74	-	-	-	215,0	-	-	-	-	212,0		
78	-	-	-	201,0	-	-	-	-	193,0		
82	-	-	-	190,0	-	-	-	-	177,0		
86	-	-	-	-	-	-	-	-	161,0		
90	-	-	-	-	-	-	-	-	147,0		
94	-	-	-	-	-	-	-	-	135,0		
95	-	-	-	-	134,0	-	-	-	132,0		
98	-	-	-	-	129,0	-	-	-	123,0		
100	-	-	-	-	126,0	-	-	-	118,0		
102	-	-	-	-	-	-	-	-	113,0		
106	-	-	-	-	-	-	-	-	103,0		
110	-	-	-	-	-	-	-	-	94,5		
112	-	-	-	-	-	-	-	90,5	88,5		
114	-	-	-	-	-	-	-	88,0	82,5		
118	-	-	-	-	-	-	-	-	71,0		
122	-	-	-	-	-	-	-	-	60,0		
126	-	-	-	-	-	-	-	-	49,0		

6 m steps of luffing jib is standard · 6 m Stufung der Wippe ist Standard · Des paliers de 6 m sont de série pour la fléchette

Main boom angle 88°, 85°, 75°, 65°, 55° and 45°; capacities for intermediate boom positions are calculated by the crane control system IC-1  
 Hauptauslegerwinkel 88°, 85°, 75°, 65°, 55° und 45°; Traglasten für Zwischenstellungen des Hauptauslegers werden von der Kransteuerung IC-1 berechnet

Jarret de flèche principale 88°, 85°, 75°, 65°, 55° et 45° ; le système de commande de la grue IC-1 calcule les charges pour les positions intermédiaires de la flèche

\* Main boom angle 88° · Hauptauslegerwinkel 88° · Jarret de flèche principale 88°

295 t + 60 t ZB		19-30 m		10,5 m		9.8 m/s		360°		ISO		
108 m + 48 m						108 m + 60 m						
		SWSL					SFSL					
		0 t		0 t - 640 t								
		85°	85°	75°	65°	55°	45°					
m	t	t	t	t	t	t	t	t	t			
24	-	230,0*	-	-	-	-	-	-	-			
26	-	225,0*	-	-	-	-	-	-	-			
28	-	220,0*	-	-	-	-	-	-	-			
30	-	214,0*	-	-	-	-	-	-	-			
32	137,0	237,0	-	-	-	-	-	-	233,0			
34	129,0	233,0	-	-	-	-	-	-	233,0			
38	114,0	224,0	-	-	-	-	-	-	233,0			
42	102,0	215,0	-	-	-	-	-	-	233,0			
46	91,5	206,0	-	-	-	-	-	-	233,0			
50	82,5	199,0	-	-	-	-	-	-	233,0			
54	74,5	192,0	-	-	-	-	-	-	229,0			
58	68,0	185,0	234,0	-	-	-	-	-	224,0			
62	-	-	232,0	-	-	-	-	-	218,0			
66	-	-	226,0	-	-	-	-	-	213,0			
70	-	-	220,0	-	-	-	-	-	204,0			
74	-	-	210,0	-	-	-	-	-	198,0			
76	-	-	207,0	-	-	-	-	-	195,5			
78	-	-	-	-	-	-	-	-	193,0			
82	-	-	-	183,0	-	-	-	-	181,0			
86	-	-	-	173,0	-	-	-	-	165,0			
90	-	-	-	163,0	-	-	-	-	151,0			
94	-	-	-	154,0	-	-	-	-	138,0			
98	-	-	-	-	-	-	-	-	127,0			
102	-	-	-	-	-	-	-	-	116,0			
104	-	-	-	-	113,0	-	-	-	111,0			
106	-	-	-	-	110,0	-	-	-	106,0			
110	-	-	-	-	105,0	-	-	-	97,0			
114	-	-	-	-	-	-	-	-	88,5			
118	-	-	-	-	-	-	-	-	80,5			
122	-	-	-	-	-	-	-	-	70,5			
124	-	-	-	-	-	-	-	70,0	65,5			
126	-	-	-	-	-	-	-	68,0	60,5			
130	-	-	-	-	-	-	-	-	50,5			
134	-	-	-	-	-	-	-	-	41,1			
138	-	-	-	-	-	-	-	-	32,1			
28	-	189,0*	-	-	-	-	-	-	-			
30	-	185,0*	-	-	-	-	-	-	-			
34	-	177,0*	-	-	-	-	-	-	-			
36	112,0	194,0	-	-	-	-	-	-	191,0			
38	105,0	192,0	-	-	-	-	-	-	191,0			
42	93,5	186,0	-	-	-	-	-	-	191,0			
46	83,5	179,0	-	-	-	-	-	-	191,0			
50	75,0	172,0	-	-	-	-	-	-	191,0			
54	67,5	166,0	-	-	-	-	-	-	191,0			
58	61,0	161,0	-	-	-	-	-	-	190,0			
62	55,0	156,0	-	-	-	-	-	-	187,0			
64	52,0	153,0	192,0	-	-	-	-	-	185,0			
66	49,9	151,0	192,0	-	-	-	-	-	183,0			
70	45,2	146,0	189,0	-	-	-	-	-	179,0			
74	-	-	185,0	-	-	-	-	-	175,0			
78	-	-	180,0	-	-	-	-	-	171,0			
82	-	-	176,0	-	-	-	-	-	165,0			
86	-	-	170,0	-	-	-	-	-	161,0			
88	-	-	167,0	-	-	-	-	-	159,0			
90	-	-	-	161,0	-	-	-	-	157,0			
94	-	-	-	152,0	-	-	-	-	145,0			
98	-	-	-	144,0	-	-	-	-	133,0			
102	-	-	-	137,0	-	-	-	-	122,0			
106	-	-	-	130,0	-	-	-	-	112,0			
110	-	-	-	-	-	-	-	-	103,0			
114	-	-	-	-	-	96,5	-	-	94,0			
118	-	-	-	-	-	92,0	-	-	86,0			
122	-	-	-	-	-	87,5	-	-	78,5			
126	-	-	-	-	-	-	-	-	71,5			
130	-	-	-	-	-	-	-	-	62,5			
134	-	-	-	-	-	-	-	57,0	53,5			
136	-	-	-	-	-	-	-	55,5	49,2			
138	-	-	-	-	-	-	-	-	45,0			
142	-	-	-	-	-	-	-	-	36,4			
146	-	-	-	-	-	-	-	-	28,0			
150	-	-	-	-	-	-	-	-	20,9			

6 m steps of luffing jib is standard · 6 m Stufung der Wippe ist Standard · Des paliers de 6 m sont de série pour la fléchette

Main boom angle 88°, 85°, 75°, 65°, 55° and 45°; capacities for intermediate boom positions are calculated by the crane control system IC-1  
Hauptauslegerwinkel 88°, 85°, 75°, 65°, 55° und 45°; Traglasten für Zwischenstellungen des Hauptauslegers werden von der Kransteuerung IC-1 berechnet

Jarret de flèche principale 88°, 85°, 75°, 65°, 55° et 45° ; le système de commande de la grue IC-1 calcule les charges pour les positions intermédiaires de la flèche

\* Main boom angle 88° · Hauptauslegerwinkel 88° · Jarret de flèche principale 88°



295 t + 60 t ZB		19-30 m		10,5 m		9.8 m/s		360°		ISO							
108 m + 72 m						108 m + 84 m											
		SWSL					SFSL			SWSL					SFSL		
		0 t	0 t - 640 t								0 t	0 t - 640 t					
		85°	85°	75°	65°	55°	45°				85°	85°	75°	65°	55°	45°	
m	t	t	t	t	t	t	t	t	t	m	t	t	t	t	t	t	t
30	-	155,0*	-	-	-	-	-	-	-	34	-	126,0*	-	-	-	-	-
34	-	151,0*	-	-	-	-	-	-	-	38	-	124,0*	-	-	-	-	-
38	-	146,0*	-	-	-	-	-	-	-	42	-	120,0*	-	-	-	-	-
40	90,5	159,0	-	-	-	-	-	156,0	-	44	69,5	129,0	-	-	-	-	127,0
42	85,0	158,0	-	-	-	-	-	156,0	-	46	65,0	128,0	-	-	-	-	127,0
46	75,5	153,0	-	-	-	-	-	156,0	-	50	57,5	125,0	-	-	-	-	127,0
50	67,5	148,0	-	-	-	-	-	156,0	-	54	50,5	121,0	-	-	-	-	127,0
54	60,0	143,0	-	-	-	-	-	156,0	-	58	44,6	118,0	-	-	-	-	127,0
58	54,0	139,0	-	-	-	-	-	156,0	-	62	39,2	114,0	-	-	-	-	127,0
62	48,3	134,0	-	-	-	-	-	156,0	-	66	34,3	111,0	-	-	-	-	127,0
66	43,3	130,0	-	-	-	-	-	154,0	-	70	29,9	107,0	-	-	-	-	125,0
70	38,7	126,0	156,0	-	-	-	-	152,0	-	74	26,0	104,0	-	-	-	-	123,0
74	34,6	123,0	155,0	-	-	-	-	149,0	-	76	24,1	103,0	123,0	-	-	-	121,5
78	30,8	119,0	153,0	-	-	-	-	147,0	-	78	22,3	101,0	123,0	-	-	-	120,0
80	29,1	118,0	152,0	-	-	-	-	145,5	-	82	19,1	98,5	122,0	-	-	-	118,0
82	-	-	151,0	-	-	-	-	144,0	-	86	16,0	95,7	121,0	-	-	-	116,0
86	-	-	148,0	-	-	-	-	141,0	-	90	13,3	93,0	119,0	-	-	-	113,0
90	-	-	145,0	-	-	-	-	136,0	-	92	12,0	91,5	118,0	-	-	-	112,0
94	-	-	142,0	-	-	-	-	133,0	-	94	-	-	117,0	-	-	-	111,0
98	-	-	139,0	126,0	-	-	-	130,0	-	98	-	-	115,0	-	-	-	107,0
100	-	-	136,0	126,0	-	-	-	127,5	-	102	-	-	113,0	-	-	-	103,0
102	-	-	-	126,0	-	-	-	125,0	-	106	-	-	110,0	104,0	-	-	101,0
106	-	-	-	123,0	-	-	-	114,0	-	110	-	-	108,0	104,0	-	-	98,5
110	-	-	-	118,0	-	-	-	105,0	-	114	-	-	-	103,0	-	-	94,0
114	-	-	-	113,0	-	-	-	96,5	-	118	-	-	-	98,0	-	-	85,5
118	-	-	-	107,0	-	-	-	88,0	-	122	-	-	-	93,5	-	-	78,0
122	-	-	-	-	81,5	-	-	80,5	-	126	-	-	-	89,0	-	-	70,5
126	-	-	-	-	77,5	-	-	73,5	-	128	-	-	-	87,0	-	-	67,2
130	-	-	-	-	74,0	-	-	66,5	-	130	-	-	-	-	-	-	64,0
134	-	-	-	-	71,0	-	-	60,0	-	132	-	-	-	-	62,5	-	61,0
138	-	-	-	-	-	-	-	52,5	-	134	-	-	-	-	61,0	-	58,0
142	-	-	-	-	-	-	-	44,5	-	138	-	-	-	-	57,5	-	53,0
144	-	-	-	-	-	-	43,3	40,6	-	142	-	-	-	-	55,0	-	45,6
146	-	-	-	-	-	-	42,0	36,7	-	144	-	-	-	-	54,0	-	41,9
148	-	-	-	-	-	-	40,7	32,9	-	146	-	-	-	-	-	-	38,2
150	-	-	-	-	-	-	-	29,1	-	150	-	-	-	-	-	-	31,1
154	-	-	-	-	-	-	-	21,5	-	154	-	-	-	-	-	26,3	24,2
158	-	-	-	-	-	-	-	14,1	-	158	-	-	-	-	-	24,2	17,4
										160	-	-	-	-	-	23,2	14,1
										162	-	-	-	-	-	-	10,8

6 m steps of luffing jib is standard · 6 m Stufung der Wippe ist Standard · Des paliers de 6 m sont de série pour la fléchette

Main boom angle 88°, 85°, 75°, 65°, 55° and 45°; capacities for intermediate boom positions are calculated by the crane control system IC-1  
 Hauptauslegerwinkel 88°, 85°, 75°, 65°, 55° und 45°; Traglasten für Zwischenstellungen des Hauptauslegers werden von der Kransteuerung IC-1 berechnet

Jarret de flèche principale 88°, 85°, 75°, 65°, 55° et 45° ; le système de commande de la grue IC-1 calcule les charges pour les positions intermédiaires de la flèche

\* Main boom angle 88° · Hauptauslegerwinkel 88° · Jarret de flèche principale 88°

295 t + 60 t ZB		19-30 m		10,5 m		9.8 m/s		360°		ISO		
108 m + 96 m						108 m + 108 m						
		SWSL					SFSL					
		0 t		0 t - 640 t								
		85°	85°	75°	65°	55°	45°					
m	t	t	t	t	t	t	t	t	t			
38	-	102,0*	-	-	-	-	-	-	-			
42	-	100,0*	-	-	-	-	-	-	-			
46	-	98,0*	-	-	-	-	-	-	-			
48	53,5	104,0	-	-	-	-	-	-	103,0			
50	49,9	104,0	-	-	-	-	-	-	103,0			
54	43,3	101,0	-	-	-	-	-	-	103,0			
58	37,4	99,5	-	-	-	-	-	-	103,0			
62	32,3	97,0	-	-	-	-	-	-	103,0			
66	27,5	94,0	-	-	-	-	-	-	102,0			
68	25,4	92,5	-	-	-	-	-	-	102,0			
70	23,3	91,5	-	-	-	-	-	-	102,0			
74	19,5	89,0	-	-	-	-	-	-	101,0			
78	16,0	86,5	-	-	-	-	-	-	99,5			
82	12,8	83,7	98,0	-	-	-	-	-	98,0			
84	11,3	82,5	98,0	-	-	-	-	-	97,0			
86	-	81,5	98,0	-	-	-	-	-	96,0			
90	-	79,2	97,5	-	-	-	-	-	94,5			
94	-	77,0	97,0	-	-	-	-	-	92,5			
98	-	74,7	95,5	-	-	-	-	-	91,0			
102	-	72,5	94,5	-	-	-	-	-	89,5			
104	-	71,5	94,0	-	-	-	-	-	88,5			
106	-	-	93,0	-	-	-	-	-	87,5			
110	-	-	92,0	-	-	-	-	-	84,0			
114	-	-	90,0	83,0	-	-	-	-	82,0			
118	-	-	88,5	83,0	-	-	-	-	80,0			
122	-	-	87,0	83,0	-	-	-	-	78,5			
126	-	-	-	83,0	-	-	-	-	72,5			
130	-	-	-	79,5	-	-	-	-	65,5			
134	-	-	-	75,5	-	-	-	-	59,0			
138	-	-	-	72,0	-	-	-	-	54,0			
140	-	-	-	70,5	-	-	-	-	51,7			
142	-	-	-	-	51,0	-	-	-	49,4			
146	-	-	-	-	48,6	-	-	-	42,7			
150	-	-	-	-	46,3	-	-	-	35,9			
154	-	-	-	-	43,4	-	-	-	29,2			
156	-	-	-	-	42,0	-	-	-	26,0			
158	-	-	-	-	-	-	-	-	22,8			
162	-	-	-	-	-	-	-	-	16,5			
164	-	-	-	-	-	-	-	15,0	13,4			
166	-	-	-	-	-	-	-	14,1	10,4			
170	-	-	-	-	-	-	-	12,3	-			

6 m steps of luffing jib is standard · 6 m Stufung der Wippe ist Standard · Des paliers de 6 m sont de série pour la fléchette

Main boom angle 88°, 85°, 75°, 65°, 55° and 45°; capacities for intermediate boom positions are calculated by the crane control system IC-1  
 Hauptauslegerwinkel 88°, 85°, 75°, 65°, 55° und 45°; Traglasten für Zwischenstellungen des Hauptauslegers werden von der Kransteuerung IC-1 berechnet

Jarret de flèche principale 88°, 85°, 75°, 65°, 55° et 45° ; le système de commande de la grue IC-1 calcule les charges pour les positions intermédiaires de la flèche

\* Main boom angle 88° · Hauptauslegerwinkel 88° · Jarret de flèche principale 88°

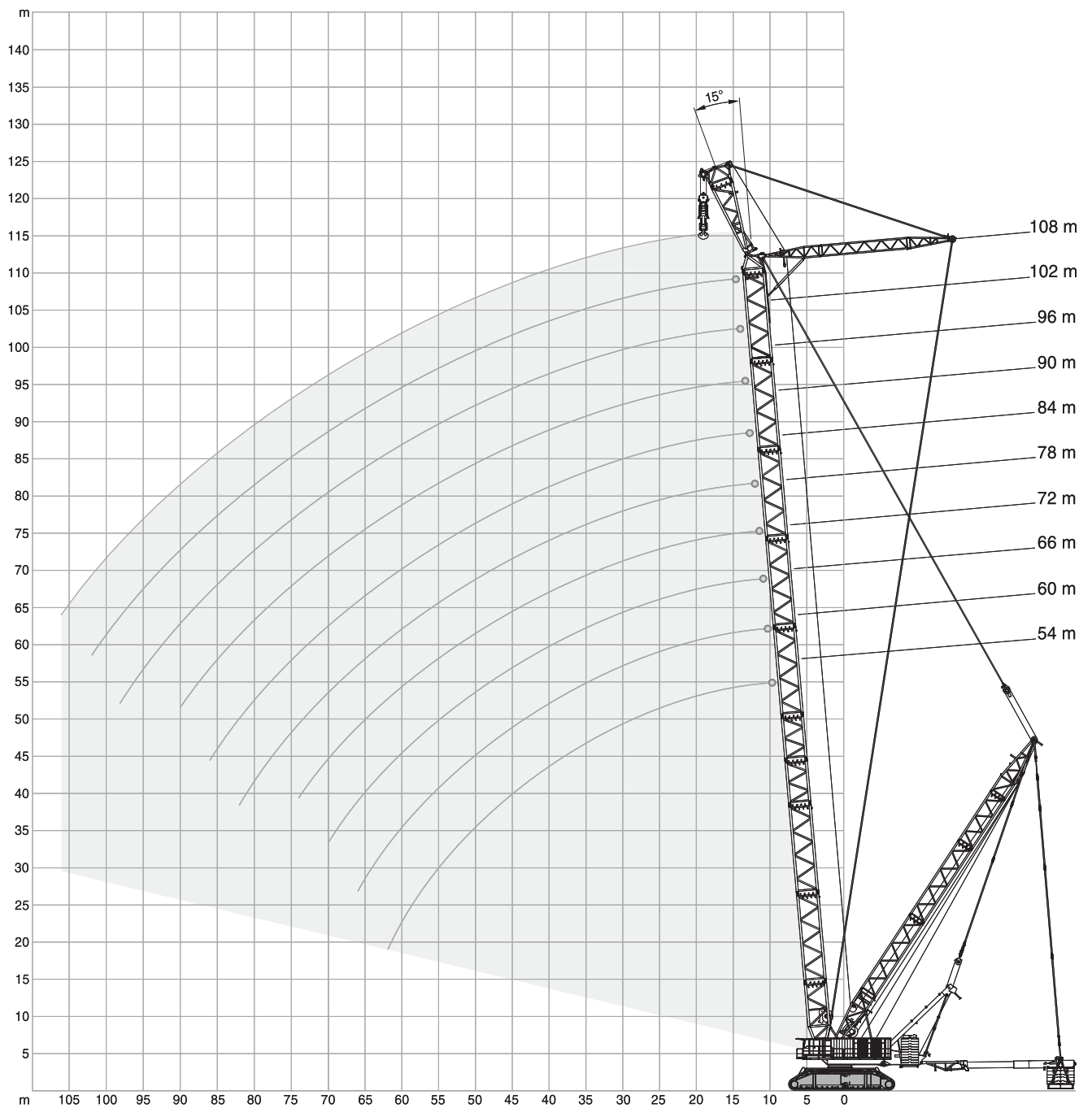

	54 m	60 m	66 m	72 m	78 m	84 m	90 m	96 m	102 m	108 m		
m	t	t	t	t	t	t	t	t	t	t	m	
14	1071,0	-	-	-	-	-	-	-	-	-	14	
16	1007,0	983,0	972,0	876,0	793,0	-	-	-	-	-	16	
18	951,0	934,0	972,0	876,0	793,0	710,0	637,0	572,0	-	-	18	
20	901,0	890,0	946,0	876,0	793,0	710,0	637,0	572,0	516,0	464,0	20	
22	857,0	850,0	904,0	876,0	793,0	710,0	637,0	572,0	516,0	464,0	22	
24	817,0	814,0	866,0	855,0	793,0	710,0	637,0	572,0	516,0	464,0	24	
26	781,0	781,0	831,0	831,0	771,0	707,0	637,0	572,0	516,0	464,0	26	
28	748,0	751,0	798,0	801,0	764,0	700,0	634,0	572,0	516,0	464,0	28	
30	718,0	723,0	751,0	745,0	739,0	689,0	630,0	570,0	515,0	464,0	30	
34	663,0	657,0	651,0	645,0	639,0	633,0	623,0	563,0	513,0	461,0	34	
38	584,0	578,0	572,0	566,0	560,0	554,0	549,0	543,0	507,0	459,0	38	
42	510,0	514,0	508,0	502,0	496,0	490,0	484,0	478,0	473,0	438,0	42	
46	438,0	462,0	455,0	449,0	443,0	437,0	431,0	425,0	419,0	413,0	46	
50	377,0	406,0	409,0	403,0	397,0	391,0	386,0	380,0	374,0	368,0	50	
54	334,0	352,0	371,0	365,0	358,0	352,0	347,0	341,0	335,0	329,0	54	
58	291,0	305,0	326,0	331,0	325,0	319,0	313,0	307,0	302,0	295,0	58	
62	245,0	273,0	284,0	300,0	297,0	290,0	285,0	278,0	273,0	266,0	62	
66	-	237,0	246,0	263,0	272,0	265,0	259,0	253,0	247,0	241,0	66	
70	-	-	225,0	229,0	242,0	243,0	237,0	231,0	225,0	219,0	70	
74	-	-	-	201,0	212,0	220,0	218,0	212,0	206,0	199,0	74	
78	-	-	-	-	184,0	194,0	200,0	194,0	188,0	182,0	78	
82	-	-	-	-	166,0	169,0	177,0	179,0	173,0	166,0	82	
86	-	-	-	-	-	147,0	155,0	159,0	159,0	152,0	86	
90	-	-	-	-	-	-	134,0	139,0	142,0	139,0	90	
94	-	-	-	-	-	-	-	120,0	124,0	125,0	94	
98	-	-	-	-	-	-	-	105,0	108,0	109,0	98	
102	-	-	-	-	-	-	-	-	91,5	94,0	102	
106	-	-	-	-	-	-	-	-	-	79,5	106	

## Anmerkungen zu den Tragfähigkeiten · Conditions d'utilisation

Ratings are in compliance with ISO 4305.

Weight of hook blocks and slings is part of the load, and is to be deducted from the capacity ratings. Consult operation manual for further details.

**Note:** Data published herein is intended as a guide only and shall not be construed to warrant applicability for lifting purposes. Crane operation is subject to the computer charts and operation manual both supplied with the crane.

In some instances the superlift counterweight does not lift off the ground with the indicated load.

---

Tragfähigkeiten entsprechen ISO 4305.

Das Gewicht der Unterflaschen, sowie die Lastaufnahmemittel, sind Bestandteile der Last und sind von den Tragfähigkeitsangaben abzuziehen.

Weitere Angaben in der Bedienungsanleitung des Kranes.

**Anmerkung:** Die Daten dieser Broschüre dienen nur zur allgemeinen Information; für ihre Richtigkeit übernehmen wir keine Haftung. Der Betrieb des Kranes ist nur mit den Original-Tragfähigkeitstabellen und mit der Bedienungsanleitung zulässig, die mit dem Kran mitgeliefert werden.

In einigen Fällen hebt das Superliftgegengewicht bei den angegebenen Traglasten nicht ab.

---

Le tableau de charges est conforme à la norme ISO 4305.

Les poids du crochet-moufle et de tous les accessoires d'élingage font partie de la charge et sont à déduire des charges indiquées. Pour plus de détails consulter la notice d'utilisation de la grue.

**Nota:** Les renseignements ci-inclus sont donnés à titre indicatif et ne représentent aucune garantie d'utilisation pour les opérations de levage.

La mise en service de la grue n'est autorisée qu'à condition que les tableaux de charges ainsi que le manuel de service, tels que fournis avec la grue, soient observés.

Le contrepoids du superlift ne décolle pas dans certaines configurations des tableaux de charge.

## Crawler Carrier

5-section carrier comprising car body, two cross axles and two split-type crawler side frames. Car body, cross axles and side frames are pin-connected hydraulically. Track width: 10.5 m.

<b>Car body</b>	Bending- and torsion-resistant welded structure fabricated from high-strength fine grain structural steel. Quick-disconnect fittings (optional) facilitate removal of slew ring from car body to minimise weight for transportation.
<b>Cross axles</b>	Bending- and torsion-resistant welded structure fabricated from high-strength fine grain structural steel incl. hydraulic jack legs.
<b>Crawler side frames</b>	Bending- and torsion-resistant welded structure fabricated from high-strength fine grain structural steel. Split-type side frames to minimise weight for transportation. Centralised lubrication included as standard.
<b>Crawlers</b>	Crawler pads made of heat-treated high-strength cast steel. 15 rollers per crawler with hardened rolling surfaces.
<b>Drive</b>	The crawlers are each driven by two hydraulic motors through closed planetary gear reduction units running in oil bath, equipped with spring loaded, hydraulically released holding brakes. Each crawler provides independent, infinitely variable control and counter-rotation capability. Quadro-Drive as standard.
<b>Slew unit</b>	Four slew gearboxes in car body powered by hydraulic motors through closed planetary gear units running in oil bath. Spring loaded, hydraulically released holding brake and non-wearing hydraulic braking.

## Superstructure

<b>Counterweight</b>	295 t in combination with 60 t central ballast.
<b>Frame</b>	Torsion-resistant welded structure fabricated from high-strength fine grain structural steel. Longitudinal beam construction to accommodate three rope drums and boom hoist. Split-type superstructure for ease of transportation.
<b>Power and control module</b>	Two independent drive units incl. pump distribution gearbox and pumps are contained in a separate module which is connected to the side of the superstructure. Power comes from a MTU diesel engine type OM 502 LA. Output to DIN 70020: 380 kW (516 HP) at 2000 <sup>1</sup> /min, torque 2400 Nm at 1080 <sup>1</sup> /min. The engine complies with EUROMOT 3a, EPA T3 and Carb regulations. Pump distribution gearbox with five variable displacement axial piston pumps and gear pumps. The power and control module includes cabin, complete electrics and electric generators as standard. Fuel tank capacity: 2000 l.
<b>Rope drums</b>	Standard superstructure equipment includes three rope drums – hoist 1, hoist 2 and boom hoist. Rope drums powered through closed planetary gear units running in oil bath. All rope drums have hydraulically released multi-disc brakes and non-wearing hydraulic braking for load lowering. Rope ends of all drums provided with quick-connect rope end fittings. Hydraulically pinned hoists H1 and H2 (optional H3) can be removed in order to minimise weight for transportation.
<b>Control system</b>	Terex IC-1: Electronic proportional valve pilot control integrated in stored-program control system incl. diagnostic. Two multi-color monitors, load indicator operated via a touch screen. Working speeds infinitely variable controlled by the lever position. Automatic power control for optimal utilisation of engine output. Standard working range limitation and ground pressure indicator.
<b>Cabin</b>	Spacious comfortable cab located at front end of power module. Large laminated glass for front and roof windows, computerised air conditioner as standard and self-contained hot air heater. Front console includes instrumentation and crane controls as well as two graphic displays. It can be tilted back, together with the operator seat, for an improved operator view of the boom point. Camera systems for monitoring the rope drums and SL ballast, hour meter, load moment indicator, two working lights, storage cabinets and refrigerator are included as standard.
<b>Electrical equipment</b>	24 V system (2 batteries 12 V / 180 Ah). 3-phase alternator 24 V, 80 A. Plus 3-phase generator 400 V 50 Hz 20 kVA for air conditioner, heater, lighting and multiple use on the job site. Emergency generator 400 V 50 Hz 16 kVA.
<b>Quick-connection</b>	Hydraulic quick-disconnect fittings on superstructure and carrier as standard.

## Optional Equipment

<b>Counterweight carrier</b>	The counterweight carrier with a max. total weight of 640 t is adjustable from 19 m to 25 m or from 24 m to 30 m from the centre of rotation, and can be operated in the circular path, trailing and $\pm 30^\circ$ parallel travel modes. Deadweight 130 t, strips down to three components for easy transport.
------------------------------	--

**Superlift counterweights**

Further options on request!

## Boom Configurations

<b>General</b>	Tubular chord lattice structure fabricated from high-strength fine grain structural steel. Walkways on boom, jib and mast. Hydraulic pinning.
<b>SSL</b>	Main boom: foot section 10 m, inserts 6 m and 12 m, boom head 2 m with 2 sheave-sets. Superlift equipment. Main boom lengths: 54-108 m.
<b>HSSL</b>	Main boom: Using the heavy sections of main boom Superlift equipment. Main boom lengths: 48-84 m.
<b>SSL / LSL (SGL 108 m)</b>	Main boom: foot section 10 m, inserts 6 m and 12 m, extended by jib inserts 6 m and 12 m, heavy-lift top 2 m with 1 sheave-set from main boom SSL. Superlift equipment. Main boom lengths: 114-156 m
<b>SWSL</b>	Main boom: same as SSL. Offset 88° to 45°. Luffing fly jib: foot section 10 m, inserts 6 m and 12 m, heavy-lift top 2 m with 1 sheave-set from main boom SSL. Superlift equipment. Main boom lengths: 54-108 m Jib lengths: 36-108 m.
<b>SFSL</b>	Same as SWSL. Offset fly jib 15°.
<b>SFVL</b>	Main boom: same as SSL. Fixed fly jib: foot section 10 m, heavy-lift top 2 m with 2 sheave-sets from main boom SSL. Superlift equipment. Main boom lengths: 54-108 m Jib length: 12 m Offset: 15°
<b>Pinning of boom</b>	Hydraulic assisted pinning of boom sections as standard.
<b>Reeving winch</b>	Mounted on superstructure as standard.
<b>Operator aids</b>	Electronic load indicator, hoist limit switch, limit switches for boom movements, hydraulic boom backstops, anemometer.

## Superlift Configurations

<b>Tele-SL</b>	Mast 50 m (type 2621), counterweight tray 640 t or counterweight carrier for max. 640 t optional. Superlift radius infinitely variable during operation: 19 m to 25 m with a mast radius of 22 m and 24 m to 30 m with a mast radius of 26.4 m.
----------------	--

## Optional Equipment

<b>Runner equipment 3 m – 70 t</b>	For 2 lines, mounted on main boom or jib heads. Distance to sheave set in steep boom position approx. 1.3 m. Lifting capacity: max. 70 t.
<b>Hoist H3</b>	Mounted on superstructure.
<b>Fire suppression system</b>	Automatic fire suppression system incl. shutters at container.
<b>Fire detection system</b>	Detection only.
<b>Bunk bed in cabin</b>	Foldable bunk-bed.
<b>Folding seats in cabin</b>	Two folding sets in cabin.
<b>Fall protection</b>	For main boom, jib and SL mast.

## Raupenunterwagen

	Der Raupenunterwagen ist 5-teilig und besteht aus einem Mittelstück, zwei Querträgern und zwei geteilten Raupenträgern. Raupenträger, Mittelstück und Querträger werden hydraulisch verbolzt. Die Spurbreite beträgt 10,5 m.
Mittelstück	Biege- und verwindungssteife Schweißkonstruktion aus hochfestem Feinkornbaustahl. Die Rollendrehverbindung sitzt am Mittelstück und ist mit Schnellspannmutter (optional) auf einfache Weise zur Reduzierung des Transportgewichtes lösbar.
Querträger	Biege- und verwindungssteife Schweißkonstruktion aus hochfestem Feinkornbaustahl mit hydraulischer Abstützung.
Raupenträger	Biege- und verwindungssteife Schweißkonstruktion aus hochfestem Feinkornbaustahl. Geteilter Raupenträger zur Minimierung der Transportgewichte. Zentralschmieranlage serienmäßig.
Raupen	Bodenplatten der Raupenketten aus vergütetem hochfesten Stahlguss. 15 Laufrollen je Raupe mit gehärteten Laufflächen.
Antrieb	Die Raupen werden von je zwei Hydromotoren über geschlossene, ölbadgeschmierte Planetengetriebe mit federbelasteten, hydraulisch gelüfteten Haltebremsen angetrieben. Jede Seite ist stufenlos, einzeln und gegenläufig steuerbar. Quadro-Antrieb serienmäßig.
Drehwerk	Vier Drehwerke im Mittelstück mit Antrieb durch Hydromotor über geschlossenes, ölbadgeschmiertes Planetengetriebe. Federbelastete, hydraulisch gelüftete Haltebremse und verschleißfreie hydraulische Bremsung.

## Oberwagen

Gegengewicht	295 t in Verbindung mit 60 t Zentralballast.
Rahmen	Verformungssteife Schweißkonstruktion aus hochfestem Feinkornbaustahl. Die Längsträgerkonstruktion dient der Aufnahme von drei Winden und dem Einziehwerk. Aus Transportgründen ist der Oberwagen geteilt ausgeführt.
Antriebsmodul	Zwei voneinander unabhängige Antriebseinheiten samt Pumpenverteiler und Pumpen sitzen in einem separaten Modul, das seitlich am Oberwagen angebaut wird. Antriebstyp: MTU Dieselmotor Typ OM 502 LA. Leistung nach DIN 70020: 380 kW (516 PS) bei 2000 1/min, Drehmoment 2400 Nm bei 1080 1/min. Der Motor erfüllt die EUROMOT 3a, EPA T3 und Carb-Vorschriften. Pumpenverteilergetriebe mit fünf verstellbaren Axialkolbenpumpen und zusätzlichen Zahnradpumpen. Im Antriebsmodul sind serienmäßig die Kabine, die gesamte Elektrik sowie die Stromerzeuger integriert. Kraftstoffbehälter: 2000 l.
Seilwinden	Der Oberwagen ist serienmäßig mit drei Seilwinden – Hubwerk 1, Hubwerk 2 und Einziehwerk – ausgerüstet. Der Antrieb der Winden erfolgt über geschlossene, ölbadgeschmierte Planetengetriebe. Alle Seilwinden sind mit, hydraulisch gelüfteten Lamellenbremsen und verschleißfreier hydraulischer Bremsung für den Senkvorgang ausgerüstet. Die Seilenden aller Winden sind mit Pressfitting und Taschen ausgestattet. Zur Reduzierung der Transportgewichte können die hydraulisch verbolzten Winden H1 und H2 (optional H3) ausgebaut werden.
Steuerung	Terex IC-1: Elektronische Proportionalventilvorsteuerung integriert in eine speicherprogrammierte Steuerung mit Fehlerdiagnose. Zwei Farbbildschirme, Bedienung über Touchscreen. Die Arbeitsgeschwindigkeiten werden durch die Hebelstellung stufenlos geregelt. Leistungsregelung der Antriebe zur optimalen Ausnutzung der Motorleistung. Serienmäßig Arbeitsbereichsbegrenzung und Anzeige der Bodenpressung.
Kabine	Die geräumige Komfortkabine ist im vorderen Bereich des Antriebsmoduls angeordnet. Sie ist mit großzügiger Sicherheitsverglasung auch im Dachbereich, computergesteuerter Klimaanlage serienmäßig und motorunabhängiger Warmluftheizung ausgestattet. Steuer- und Kontrollelemente für die Kranfunktionen sowie zwei Grafik-Displays befinden sich in der Frontkonsole. Diese ist zur Sichtverbesserung gemeinsam mit dem Fahrersitz nach hinten neigbar. Kamerasysteme für die Überwachung von Winden und SL-Ballast, Betriebsstundenzähler, Lastmomentanzeige, zwei Arbeitsscheinwerfer, Ablageschränke und Kühlschrank serienmäßig.
Elektrische Anlage	24 V System (2 x Batterie 12 V / 180 Ah). 3-Phasen Wechselstromgenerator 24 V, 80 A. Zusätzlich 3-Phasengenerator 400 V 50 Hz 20 KVA für Klimaanlage, Heizung, Beleuchtung und vielfältige Anwendungen auf der Baustelle. Notstromaggregat 400 V 50 Hz 16 KVA.
Schnellverbindung	Hydraulische Schnellverbindung Oberwagen / Unterwagen serienmäßig.

## Zusatzrüstung

Gegengewichtswagen	Der Gegengewichtswagen mit max. 640 t Gesamtgewicht kann von 19 m bis 25 m bzw. 24 m bis 30 m zur Drehmitte frei verstellbar und in den Fahrzuständen Drehen, Hinterherfahrt und Nachlauf $\pm 30^\circ$ betrieben werden. Eigengewicht 130 t, zum Transport in drei Komponenten zerlegbar.
Superlift-Gegengewichte	
Weitere Zusatzausrüstungen auf Anfrage!	



## Auslegervarianten

<b>Allgemein</b>	Gitter-Rohrkonstruktion aus hochfestem Feinkornbaustahl. Begehungen auf Hauptausleger, Hilfsausleger und Superlift-Mast. Hydraulisch verbolzbare.
<b>SSL</b>	Hauptausleger: Fußstück 10 m, Zwischenstücke 6 m und 12 m, Anschlusskopf 2 m mit 2 Rollensätzen. Superlift-Einrichtung. Hauptauslegerlängen: 54-108 m
<b>HSSL</b>	Hauptausleger: Unter Verwendung der schweren Komponenten des Hauptauslegers. Superlift-Einrichtung. Hauptauslegerlängen: 48-84 m.
<b>SSL / LSL (SGL 108 m)</b>	Hauptausleger: Fußstück 10 m, Zwischenstücke 12 m und 6 m, verlängert um Hilfsauslegerzwischenstücke 12 m und 6 m, Schwerlastkopf 2 m mit 1 Rollensatz vom Hauptausleger SSL. Superlift-Einrichtung. Hauptauslegerlängen: 114-156 m
<b>SWSL</b>	Hauptausleger: wie SSL. Vorneigung 88° bis 45°. Wippbarer Hilfsausleger: Fußstück 10 m, Zwischenstücke 6 m und 12 m, Schwerlastkopf 2 m mit 1 Rollensatz vom Hauptausleger SSL. Superlift-Einrichtung. Hauptauslegerlängen: 54-108 m Hilfsauslegerlängen: 36-108 m
<b>SFSL</b>	Wie SWSL. Vorneigung des Hilfsauslegers: 15°.
<b>SFVL</b>	Hauptausleger: wie SSL. Starrer Hilfsausleger: Fußstück 10 m, Schwerlastkopf 2 m mit 2 Rollensätzen vom Hauptausleger SSL. Superlift-Einrichtung. Hauptauslegerlängen: 54-108 m Hilfsauslegerlänge: 12 m Vorneigung: 15°.
<b>Auslegerverbolzung</b>	Serienmäßig hydraulische verbolzbare Auslegerteile.
<b>Einscherwinde</b>	Serienmäßig am Oberwagen angebaut.
<b>Sicherheitseinrichtungen</b>	Elektronischer Lastmomentbegrenzer, Hubenschalter, Endschalte für Auslegerbewegungen, hydraulische Ausleger-Rückfallsicherungen, Windmesser.

## Superlift-Konfigurationen

<b>Tele-SL</b>	Mast 50 m (Typ 2621), Gegengewichtstraverse 640 t oder optional Gegengewichtswagen mit max. 640 t. Superlift-Radius stufenlos im Betrieb verstellbar von 19 m bis 25 m bei Mastradius 22 m und von 24 m bis 30 m bei Mastradius 26,4 m.
----------------	--

## Zusatzrüstung

<b>Runner 3 m – 70 t</b>	Für 2 Seile, Anbau an Haupt- oder Hilfsauslegerkopf. Abstand zu Rollensatz bei Auslegersteilstellung ca. 1,3 m. Tragfähigkeit: max. 70 t.
<b>Hubwerk H3</b>	Wird im Oberwagen eingebaut.
<b>Brandschutzsystem</b>	Automatisches Brandschutzsystem mit Verschlussklappen in Containerwänden.
<b>Brandmeldesystem</b>	Nur Brandmeldung.
<b>Schlafgelegenheit in der Kabine</b>	Klappbett.
<b>Klappsitze in der Kabine</b>	Zwei Klappsitze in der Kabine.
<b>Absturzicherung</b>	Für Hauptausleger, Hilfsausleger und SL-Mast.

## Châssis à chenilles

Le porteur à chenilles est réalisé en 5 parties et se compose d'une partie centrale, de deux traverses et de deux trains de chenilles divisibles en deux parties. Les trains de chenilles, la partie centrale et les traverses sont verrouillés hydrauliquement. La voie est de 10,5 m.

<b>Partie centrale</b>	Structure mécano-soudée rigide à la flexion et à la torsion, réalisée en acier de construction à grains fins à haute résistance. Ecrous à serrage rapide (en option) facilitant le démontage de la couronne d'orientation pour réduire les poids de transport.
<b>Traverses</b>	Structure mécano-soudée rigide à la flexion et à la torsion, réalisée en acier de construction à grains fins à haute résistance, avec calage hydraulique.
<b>Trains de chenille</b>	Structure mécano-soudée rigide à la flexion et à la torsion, réalisée en acier de construction à grains fins à haute résistance. Trains de chenilles divisibles pour minimiser les poids de transport. Graissage centralisé en série.
<b>Chenilles</b>	Patins de chenilles en acier coulé trempé et revenu à haute résistance. 15 galets par chenille avec surfaces de roulement trempées.
<b>Entraînement</b>	Les chenilles sont entraînées chacune par deux moteurs hydrauliques avec réducteurs planétaires en carter étanche sous bain d'huile, munis de freins d'arrêt à ressorts à desserrage hydraulique. Chaque côté permet un mouvement réglable sans paliers individuel et dans le sens opposé. Entraînement quadro en série.
<b>Mécanisme d'orientation</b>	Quatre mécanismes d'orientation dans la partie centrale entraînés par moteurs hydrauliques avec réducteurs planétaires en carter étanche sous bain d'huile. Freins d'arrêt à ressorts à desserrage hydraulique et freinage anti-usure hydraulique.

## Partie supérieure

<b>Contrepoids</b>	295 t en combinaison avec 60 t de lest central.
<b>Charpente</b>	Structure mécano-soudée résistant à la déformation, réalisée en acier de construction à grains fins à haute résistance. Structure à longerons servant à recevoir trois treuils et le mécanisme de relevage. La partie supérieure est divisible en deux parties pour des raisons de transport.
<b>Module de motorisation et de commande</b>	Deux unités d'entraînement indépendantes l'une de l'autre, y compris la boîte de transfert à pompes et les pompes, sont disposées dans un module séparé attaché latéralement à la partie tournante. Type de motorisation : moteur diesel MTU type OM 502 LA. Puissance selon DIN 70020 : 380 kW (516 CV) à 2000 tr/mn, couple 2400 Nm à 1080 tr/mn. Le moteur satisfait aux règlements EUROMOT 3a, EPA T3 et Carb. Boîte de transfert à cinq pompes à pistons axiaux à débit variable et pompes à engrenage auxiliaires. La cabine, tout le système électrique et les équipements de génération de courant sont logés de série dans le module de motorisation et de commande. Réservoir de carburant : 2000 l.
<b>Treuils</b>	La partie supérieure est équipée de série de trois treuils – le treuil 1, le treuil 2 et le mécanisme de relevage. L'entraînement des treuils s'effectue avec réducteurs planétaires en carter étanche sous bain d'huile. Tous les treuils sont équipés de freins à disques multiples à ressorts à desserrage hydraulique et d'un freinage anti-usure hydraulique pour la descente. Les extrémités des câbles de tous les treuils sont munies des attaches à jonction rapide. Les treuils H1 et H2 (H3 en option) verrouillés hydrauliquement peuvent être déposés pour réduire le poids au transport.
<b>Commande</b>	Terex IC-1 : Pilotage électronique de soupapes proportionnels intégré dans un automate programmable avec diagnostic de dysfonctionnement. Deux écrans couleur, commande du C.E.C. par écran tactile. Les vitesses de travail sont réglées sans paliers par la position du levier. Régulation automatique pour une exploitation optimale de la puissance du moteur. Limitation de portée et force de pression sur base en série.
<b>Cabine</b>	La cabine spacieuse et confortable est placée à la partie avant du module de motorisation et de commande. Large pare-brise et toit en vitrage blindé, climatisation commandée par ordinateur de série et chauffage à air chaud indépendant du moteur. Console frontale avec éléments de commande et de contrôle pour les fonctions de la grue ainsi que deux affichages graphiques. Cette console est inclinable en arrière avec le siège conducteur, assurant au grutier une visibilité optimale. Systèmes de caméra pour surveiller les treuils et lest SL, compteur d'heures de service, affichage du moment de charge, 2 projecteurs de travail, armoires de rangement et réfrigérateur livrés en série.
<b>Installation électrique</b>	Système 24 V (2 batteries 12 V / 180 Ah). Génératrice à courant alternatif triphasé 24 V, 80 A. Génératrice triphasée supplémentaire à 400 V 50 Hz 20 kVA pour la climatisation, le chauffage, l'éclairage et de multiples applications sur le chantier. Groupe électrogène de secours 400 V 50 Hz 16 kVA.
<b>Connexion rapide</b>	Connexion rapide hydraulique entre partie supérieure et châssis en série.

## Optional Equipment

<b>Chariot contrepoids</b>	Le chariot à contrepoids avec un poids total maxi de 640 t peut être réglé librement entre 19 m et 25 m ou entre 24 m et 30 m du centre de rotation et peut être actionné en modes Orientation, marche arrière et marche en parallèle $\pm 30^\circ$ . Poids mort 130 t, démontable en trois parties pour un transport facile.
<b>Contrepoids Superlift</b>	
<b>Équipements supplémentaires sur demande!</b>	

## Combinaisons de flèche

<b>Général</b>	Construction tubulaire treillie en acier de haute résistance à grains fins. Passerelles sur flèche principale, volée variable et mât superlift. Verrouillage hydraulique.
<b>SSL</b>	Flèche principale : pied 10 m, tronçons 6 m et 12 m, tête de flèche 2 m avec 2 jeux de poulies. Équipement Superlift. Longueurs de flèche principale : 54-108 m
<b>HSSL</b>	Flèche principale : Avec utilisation des composants lourds de la flèche principale. Équipement Superlift. Longueurs de flèche principale : 48-84 m.
<b>SSL / LSL (SGL 108 m)</b>	Flèche principale : pied 10 m, tronçons 6 m et 12 m, allongée de tronçons de fléchette 6 m et 12 m, tête pour charges lourdes 2 m avec 1 jeu de poulie de flèche principale SSL. Équipement Superlift. Longueurs de flèche principale : 114-156 m
<b>SWSL</b>	Flèche principale : idem SSL. Inclinaison 88° à 45° Fléchette à volée variable : pied 10 m, tronçons 6 m et 12 m, tête pour charges lourdes 2 m avec 1 jeu de poulie de flèche principale SSL. Équipement Superlift. Longueurs de flèche principale : 54-108 m Longueurs de volée variable : 36-108 m
<b>SFSL</b>	Idem SWSL. Inclinaison de fléchette : 15°.
<b>SFVL</b>	Flèche principale : idem SSL. Fléchette fixe : pied 10 m, tête pour charges lourdes 2 m avec 2 jeux de poulies de flèche principale SSL. Équipement Superlift. Longueurs de flèche principale : 54-108 m Longueur de volée variable : 12 m Inclinaison : 15°.
<b>Boulonnement de flèche</b>	Boulonnement hydraulique des intercalaires de flèche en série.
<b>Tambour de mouflage</b>	Monté sur la partie supérieure en série.
<b>Sécurité</b>	Contrôleur d'état de charge électronique, contacteur de fin de course haut, limiteurs de mouvements de la flèche, retenues hydrauliques anti-basculement de la flèche, anémomètre.

## Combinaisons Superlift

<b>Tele-SL</b>	Mât 50 m (type 2621), panier du contrepoids 640 t ou chariot contrepoids en option avec max. 640 t. Rayon du Superlift variable de 19 m à 25 m pour un rayon de mât 22 m et de 24 m à 30 m de pour un rayon de mât 26,4 m.
----------------	---

## Équipements optionnels

<b>Équipement potence 3 m – 70 t</b>	Pour 2 lignes, montées sur flèche principale ou têtes de fléchette. Distance au jeu de poulies avec la flèche en position relevée env. 1,3 m. Capacité de levage : max. 70 t.
<b>Treuil H3</b>	Monté sur la partie supérieure.
<b>Système anti-incendie</b>	Système anti-incendie automatique avec clapets coupe-feu automatiques sur conteneur.
<b>Système de détection d'incendie</b>	Détection uniquement.
<b>Lit superposé dans la cabine</b>	Lit superposé rabattable.
<b>Sièges pliant dans la cabine</b>	2 sièges pliant dans la cabine.
<b>Protection antichute</b>	Pour flèche principale, volée variable et mât SL.

## **www.terexcranes.com**

Effective Date: July 2010.

Product specifications and prices are subject to change without notice or obligation. The photographs and/or drawings in this document are for illustrative purposes only. Refer to the appropriate Operator's Manual for instructions on the proper use of this equipment. Failure to follow the appropriate Operator's Manual when using our equipment or to otherwise act irresponsibly may result in serious injury or death. The only warranty applicable to our equipment is the standard written warranty applicable to the particular product and sale and Terex makes no other warranty, express or implied. Products and services listed may be trademarks, service marks or trade-names of Terex Corporation and/or its subsidiaries in the USA and other countries. All rights are reserved. Terex® is a registered trademark of Terex Corporation in the USA and many other countries.

Gültig ab: Juli 2010.

Produktbeschreibungen und Preise können jederzeit und ohne Verpflichtung zur Ankündigung geändert werden. Die in diesem Dokument enthaltenen Fotos und/oder Zeichnungen dienen rein anschaulichen Zwecken. Anweisungen zur ordnungsgemäßen Verwendung dieser Ausrüstung entnehmen Sie bitte dem zugehörigen Betriebshandbuch. Nichtbefolgung des Betriebshandbuchs bei der Verwendung unserer Produkte oder anderweitig fahrlässiges Verhalten kann zu schwerwiegenden Verletzungen oder Tod führen. Für dieses Produkt wird ausschließlich die entsprechende, schriftlich niedergelegte Standardgarantie gewährt. Terex leistet keinerlei darüber hinaus gehende Garantie, weder ausdrücklich noch stillschweigend. Die Bezeichnungen der aufgeführten Produkte und Leistungen sind gegebenenfalls Marken, Servicemarken oder Handelsnamen der Terex Corporation und/oder ihrer Tochtergesellschaften in den USA und anderen Ländern. Alle Rechte vorbehalten. „TEREX“ ist eine eingetragene Marke der Terex Corporation in den USA und vielen anderen Ländern.

Date d'effet : Juillet 2010.

Les spécifications et prix des produits sont sujets à modification sans avis ou obligation. Les photographies et/ou dessins contenus dans ce documents sont uniquement pour illustration. Veuillez vous référer à la notice d'utilisation appropriée pour les instructions quant à l'utilisation correcte de cet équipement. Tout manquement au suivi de la notice d'utilisation appropriée lors de l'utilisation de notre équipement ou tout acte autrement irresponsable peut résulter en blessure corporelle sérieuse ou mortelle. La seule garantie applicable à notre équipement est la garantie standard écrite applicable à un produit et à une vente spécifique. Terex n'offre aucune autre garantie, expresse ou explicite. Les produits et services proposés peuvent être des marques de fabrique, des marques de service ou des appellations commerciales de Terex Corporation et/ou ses filiales aux Etats Unis et dans les autres pays, et tous les droits sont réservés. «TEREX» est une marque déposée de Terex Corporation aux Etats Unis et dans de nombreux autres pays.

Copyright 2010 Terex Corporation

Terex Cranes, Global Marketing, Dinglerstraße 24, 66482 Zweibrücken, Germany  
Tel. +49 (0) 6332 830, Email: info.cranes@terex.com, www.terexcranes.com

Brochure Reference: TC-DS-M-E/F/G-CC 8800-1-07/10



# **WORKS FOR YOU.™**