

BT 26106



Features

- ▶ 26 t @ 6 ft capacity at rated distance from center of rotation
- ▶ 106 ft maximum boom length
- ▶ 115 ft maximum tip height
- ▶ 30/47 ft optional jib
- ▶ 162 ft maximum sheave height with 47 ft jib
- ▶ Behind cab mounting with dual operator console
- ▶ Electronic load moment indicator with work area definition
- ▶ Quick reeving dual sheave boom head

WORKS FOR YOU.™

Key

..... 3

Dimensions

Crane Dimensions 4, 5
Area of Operations 5
Mounting Specification 5
Range Diagram 6

Load charts

Boom Load Chart 7
Jib, Retracted 8
Jib, Extended 8

Technical description

Boom, Jib and Rotation 9
Operator Controls, Operator Aids 9, 10
Outriggers 10
Optional Features 10

| | | | |
|---|----------------------------|---|-------------------------------------|
|  | Main boom |  | Main Hoist |
|  | Boom length |  | Hoist line speed |
|  | Tip height |  | Part line |
|  | Telescoping mode |  | Operator aid |
|  | Boom angle |  | Controls |
|  | Working radius |  | Hydraulics |
|  | Boom with jib |  | Working temperature |
|  | Boom head |  | Outriggers |
|  | Hook block |  | Rotation / Allowable rotation range |
|  | Hook to head sheave pin |  | Boom angle |
|  | Rope – Standard / Optional |  | Boom over the rear |
|  | Rope diameter |  | Boom over the front |
|  | Rope length |  | Area of operation |
|  | Line pull |  | Working speeds |

DIMENSIONS

BT 26106

Crane Dimensions

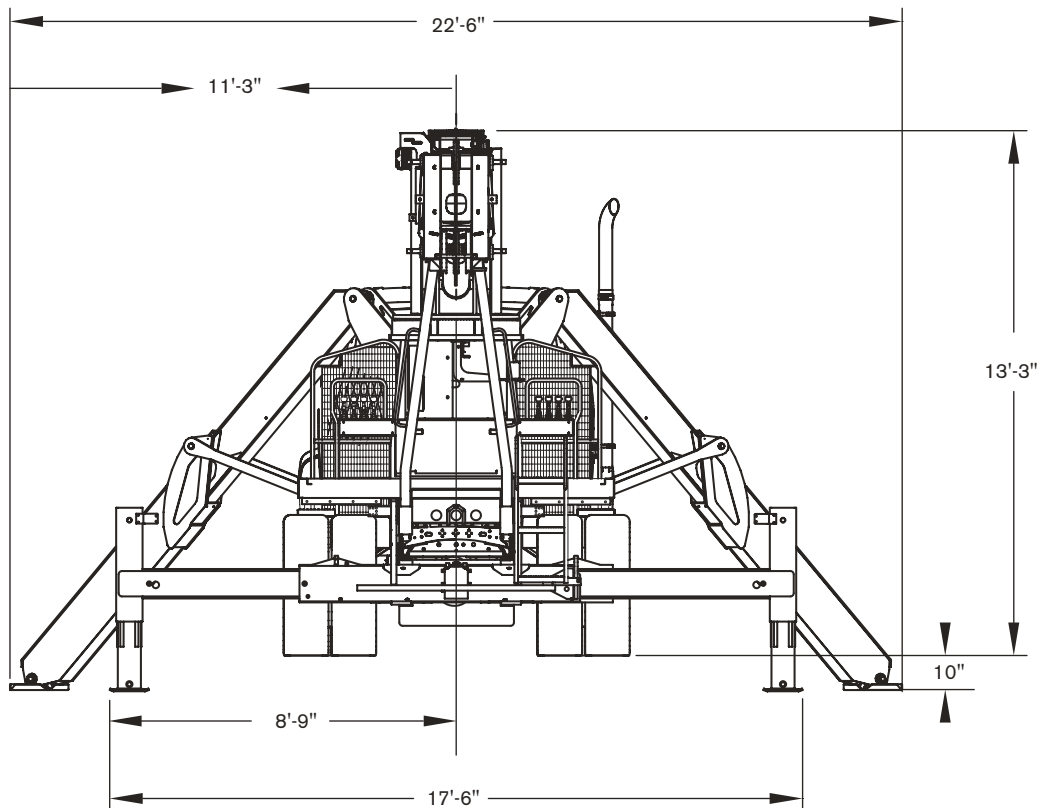
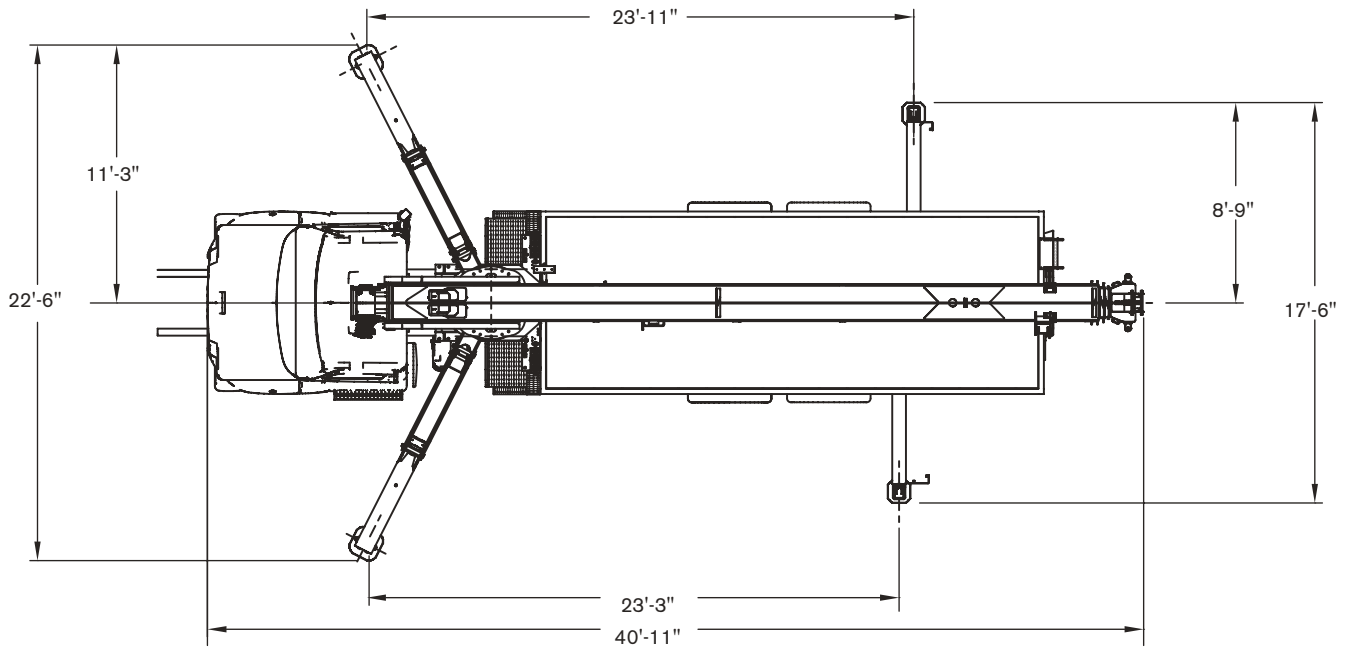

DIMENSIONS

BT 26106

Crane Dimensions

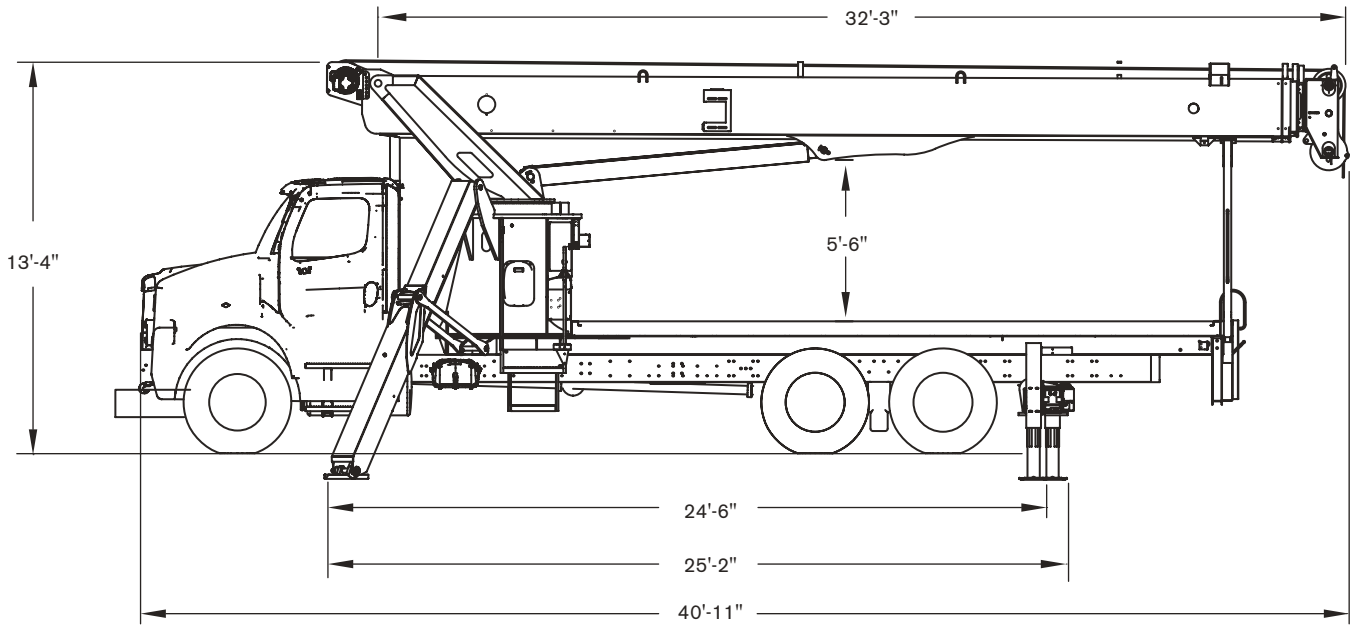

Area of Operation

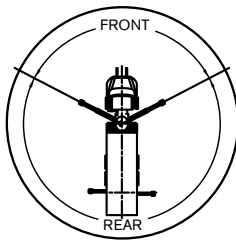

Mounting Specifications

| | | | |
|---------------------------------------|------------------|---|------------|
| Gross Vehicle Weight Rating | 52,000 lb | Estimated installed crane weight | 28,760 lbs |
| Front Axle Weight Rating | 18,000 lb | Crane fitted with jib and mounted on freightliner chassis with flatbed. | |
| Rear Axle Weight Rating | 34,000 lb | Approximate weight distribution: | |
| Wheelbase | 260 in | Front axle | 15,370 lbs |
| Cab to Axle | 192 in | Tandem axles | 30,710 lbs |
| Afterframe | 114 in | Total weight | 46,080 lbs |
| RBM per Frame Rail | 33,000,000 lb/in | Estimated freightliner bare chassis weight: | |
| Frame Height (Unloaded) | 40 in | Front axle | 9,140 lbs* |
| Vertical Exhaust Height | 110 in | Tandem axles | 8,270 lbs* |
| | | Total weight | 17,410 lbs |

* Minimum bare chassis weight requirements. Must ballast to minimum if required.

RANGE DIAGRAM

BT 26106

Outriggers Fully Extended (100%)

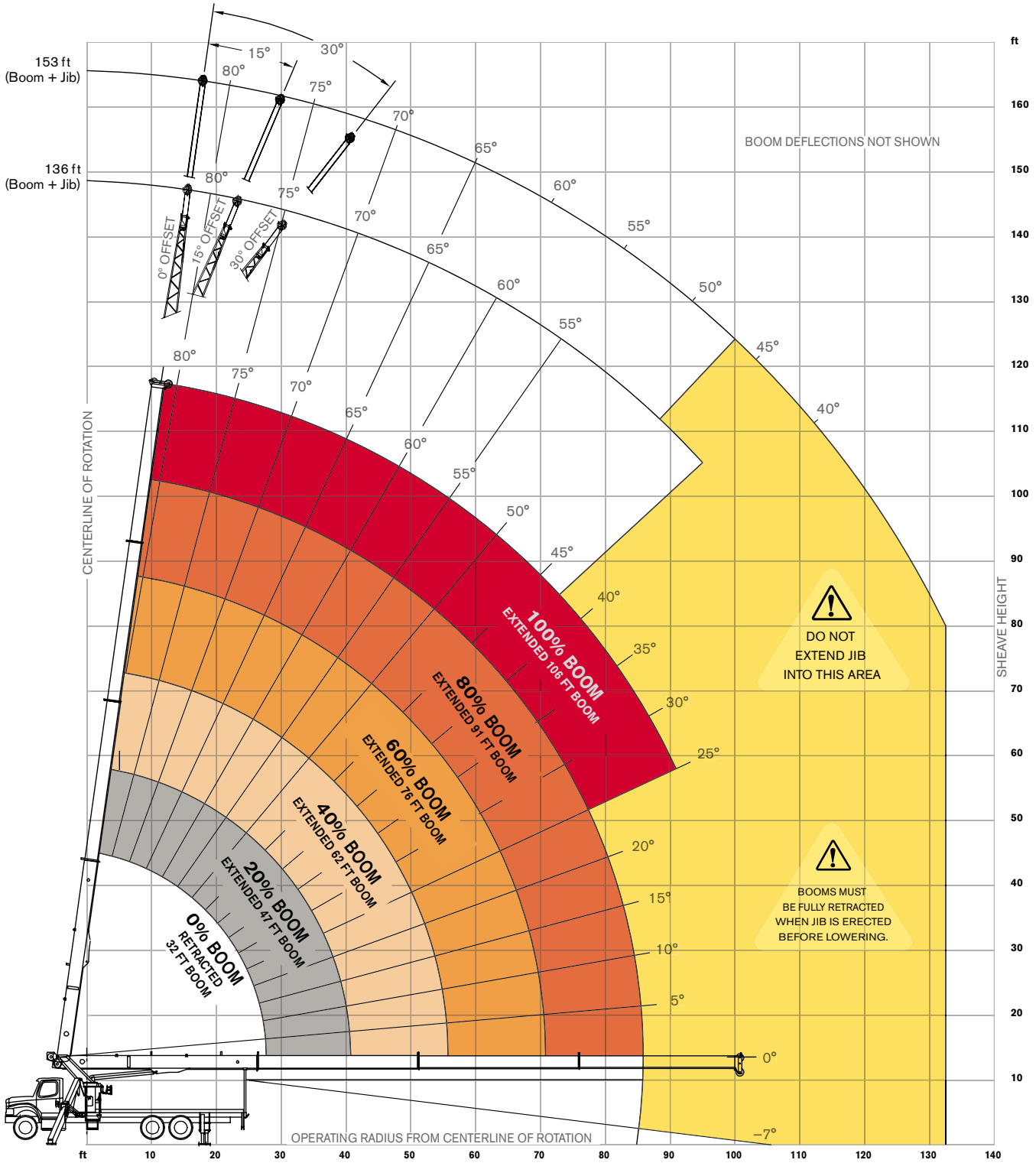
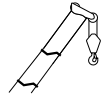

BOOM LOAD CHART

BT 26106

Outriggers Fully Extended (100%)

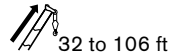

Standard ASME B30.5

| ft | Boom Length | | | | | | | | | | | | ft |
|----|-------------|--------|--------|--------|--------|--------|--------|--------|--------|--------|--------|--------|----|
| | 32 | | 47 | | 62 | | 76 | | 91 | | 106 | | |
| | lb | lb | lb | lb | lb | lb | lb | lb | lb | lb | lb | lb | |
| 6 | 52,000 | 52,000 | | | | | | | | | | | 6 |
| 8 | 40,000 | 40,000 | 29,000 | 29,000 | | | | | | | | | 8 |
| 10 | 34,000 | 34,000 | 27,000 | 27,000 | 25,400 | 25,400 | | | | | | | 10 |
| 12 | 30,000 | 30,000 | 24,950 | 24,950 | 24,000 | 24,000 | | | | | | | 12 |
| 14 | 24,700 | 24,700 | 22,850 | 22,850 | 22,000 | 22,000 | 19,000 | 19,000 | 16,000 | 16,000 | | | 14 |
| 17 | 22,000 | 21,700 | 20,450 | 20,450 | 20,000 | 20,000 | 17,000 | 17,000 | 14,600 | 14,600 | | | 17 |
| 20 | 18,000 | 17,500 | 16,950 | 16,250 | 16,000 | 15,300 | 14,500 | 14,500 | 13,000 | 13,000 | 10,000 | 10,000 | 20 |
| 25 | 14,000 | 10,850 | 12,900 | 11,600 | 13,000 | 11,500 | 12,000 | 12,000 | 11,000 | 11,000 | 9,500 | 9,500 | 25 |
| 30 | | | 10,000 | 8,300 | 10,000 | 8,650 | 9,500 | 9,500 | 8,750 | 8,750 | 9,000 | 8,500 | 30 |
| 35 | | | 7,750 | 5,900 | 8,000 | 6,300 | 8,000 | 6,700 | 7,500 | 6,700 | 8,500 | 6,700 | 35 |
| 40 | | | 6,300 | 4,200 | 6,650 | 4,650 | 6,750 | 4,900 | 6,500 | 5,000 | 7,100 | 5,100 | 40 |
| 45 | | | | | 5,300 | 3,650 | 5,500 | 3,850 | 5,500 | 4,050 | 5,800 | 4,050 | 45 |
| 50 | | | | | 4,250 | 2,700 | 4,500 | 2,950 | 4,400 | 3,100 | 4,850 | 2,950 | 50 |
| 55 | | | | | 3,450 | 1,900 | 3,650 | 2,200 | 3,800 | 2,250 | 3,950 | 2,300 | 55 |
| 60 | | | | | | | 2,900 | 1,600 | 3,050 | 1,650 | 3,200 | 1,700 | 60 |
| 65 | | | | | | | 2,250 | 1,050 | 2,450 | 1,150 | 2,550 | 1,200 | 65 |
| 70 | | | | | | | 1,750 | 500 | 1,950 | 700 | 2,000 | 800 | 70 |
| 75 | | | | | | | | | 1,450 | 400 | 1,550 | 500 | 75 |
| 80 | | | | | | | | | 1,050 | | 1,150 | | 80 |
| 85 | | | | | | | | | 700 | | 850 | | 85 |
| 90 | | | | | | | | | | | 500 | | 90 |

Notes to lifting capacity

Lifting capacities do not exceed 85% of tipping load. Weight of hook blocks and slings is part of the load, and is to be deducted from the capacity ratings. Consult operation manual for further details.

Note: Data published herein is intended as a guide only and shall not be construed to warrant applicability for lifting purposes. Crane operation is subject to the computer charts and operation manual both supplied with the crane.

LOAD CHART

BT 26106

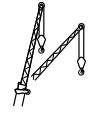

With Jib, Retracted

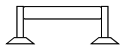

(100%)



Over Rear



Over Front

Standard ASME B30.5

| ft | Jib 30 ft | | | | | | | | | ft |
|-----|-----------|-------|-------|-----|-------|------|-----|-------|-------|-----|
| | 0° | | | 15° | | | 30° | | | |
| | ° | lb | lb | ° | lb | lb | ° | lb | lb | |
| 30 | 80 | 5,000 | 5,000 | | | | | | | 30 |
| 35 | 78 | 5,000 | 5,000 | | | | | | | 35 |
| 40 | 75 | 5,000 | 5,000 | 81 | 4,800 | 4000 | 82 | 4,000 | 4,000 | 40 |
| 45 | 72 | 4,800 | 4,250 | 79 | 4,800 | 4000 | 79 | 4,000 | 4,000 | 45 |
| 50 | 70 | 4,500 | 3,250 | 74 | 4,200 | 3850 | 77 | 4,000 | 4,000 | 50 |
| 55 | 68 | 3,800 | 2,550 | 72 | 3,700 | 3050 | 75 | 3,600 | 3,350 | 55 |
| 60 | 65 | 3,100 | 1,900 | 70 | 3,300 | 2300 | 72 | 3,200 | 2,700 | 60 |
| 65 | 63 | 2,450 | 1,300 | 67 | 2,650 | 1700 | 70 | 2,800 | 2,100 | 65 |
| 70 | 60 | 1,800 | 800 | 65 | 2,000 | 1100 | 67 | 2,350 | 1,500 | 70 |
| 75 | 58 | 1,350 | 450 | 62 | 1,600 | 750 | 64 | 1,900 | 1,100 | 75 |
| 80 | 55 | 900 | | 59 | 1,200 | 400 | 60 | 1,500 | 700 | 80 |
| 85 | 51 | 575 | | 56 | 800 | | 57 | 1,150 | 425 | 85 |
| 90 | 48 | | | 52 | 400 | | 54 | 800 | | 90 |
| 95 | 45 | | | 49 | | | 51 | 550 | | 95 |
| 100 | 41 | | | 46 | | | 48 | | | 100 |

With Jib, Extended

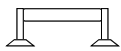

(100%)



Over Rear



Over Front

Standard ASME B30.5

| ft | Jib 47 ft | | | | | | | | | ft |
|-----|-----------|-------|-------|-----|-------|-------|-----|-------|-------|-----|
| | 0° | | | 15° | | | 30° | | | |
| | ° | lb | lb | ° | lb | lb | ° | lb | lb | |
| 30 | 82 | 4,000 | 4,000 | | | | | | | 30 |
| 35 | 80 | 4,000 | 4,000 | | | | | | | 35 |
| 40 | 78 | 4,000 | 4,000 | | | | | | | 40 |
| 45 | 76 | 3,550 | 3,300 | | | | | | | 45 |
| 50 | 74 | 3,300 | 2,500 | 79 | 3,300 | 3,300 | | | | 50 |
| 55 | 72 | 2,900 | 2,000 | 77 | 3,200 | 3,200 | | | | 55 |
| 60 | 70 | 2,300 | 1,500 | 75 | 3,100 | 3,100 | 78 | 2,500 | 2,500 | 60 |
| 65 | 67 | 1,850 | 1,100 | 73 | 2,950 | 2,550 | 76 | 2,500 | 2,500 | 65 |
| 70 | 65 | 1,400 | 700 | 70 | 2,800 | 2,000 | 74 | 2,400 | 2,400 | 70 |
| 75 | 63 | 1,050 | | 68 | 2,350 | 1,550 | 71 | 2,250 | 1,950 | 75 |
| 80 | 61 | 750 | | 65 | 1,900 | 1,150 | 69 | 2,100 | 1,500 | 80 |
| 85 | 59 | 500 | | 63 | 1,450 | 725 | 66 | 1,700 | 1,100 | 85 |
| 90 | 56 | | | 61 | 1,000 | | 63 | 1,300 | 700 | 90 |
| 95 | 54 | | | 57 | 750 | | 61 | 1,000 | | 95 |
| 100 | 51 | | | 55 | 500 | | 58 | 700 | | 100 |

Notes to lifting capacity

Lifting capacities do not exceed 85% of tipping load. Weight of hook blocks and slings is part of the load, and is to be deducted from the capacity ratings. Consult operation manual for further details.









Note: Data published herein is intended as a guide only and shall not be construed to warrant applicability for lifting purposes. Crane operation is subject to the computer charts and operation manual both supplied with the crane.



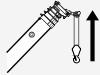





TECHNICAL DESCRIPTION

BT 26106

Boom, Jib and Rotation

| | | |
|---|---|-----------------------------------|
|  | Four-section full power fully synchronized telescopic keel boom | |
|  | Boom length | 32–106 ft |
|  | Boom maximum tip height | 115 ft |
|  | Boom elevation angle range (min/max) | -8° / 82° |
|  | Boom up/down time Boom extension/retraction time | 50/120 seconds 110/140 seconds |
|  | Boom head | 3 Sheave quick reeving |
|  | Tip height: Optional lattice jib 30/47 ft Angular offsets | 162 ft 0°, 15°, 30° |
|  | 360° non-continuous rotation | |

Operator Controls, Operator Aids

| | | |
|---|---|-------------------------------|
|  | Hydraulic 2-speed hoist | |
|  | Hoist maximum line pulls Low High | 11,854 lb 5,532 lb |
|  | Hoist 3rd layer line speeds Low High | 137 ft/min 209 ft/min |
|  | Rope diameter | 9/16" |
|  | Breaking strength Permissible line pull | 37,000 lb 10,500 lb |
|  | Rope length | 350 ft |
|  | Overhaul ball 1 Sheave block 2 Sheave block 3 Sheave block | 7 t 17.5 t 25 t 26 t |

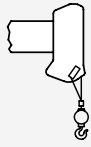

1 part line
2 part line
3 part line
4 part line
5 part line
6 part line

9,600 lb / 172 ft/min
19,200 lb / 86 ft/min
28,800 lb / 57 ft/min
38,400 lb / 43 ft/min
48,000 lb / 34 ft/min
52,000 lb / 29 ft/min

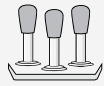

Proportional hydraulics
Independent outrigger controls
Bump throttle

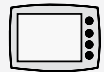

Load moment / Rated capacity indicator with work area definition
ATB system – internal wire

Outriggers



K-pattern

Front: Splayed A-link,
To outer edge of pad

22 ft 6 in

Rear, "H" pattern (out and down),
To outer edge of pad

17 ft 6 in

Optional Features

- Two-stage jibs
- Rotation resistant rope
- Multi-part load blocks
- Main hoist with 2 speed motor
- Heavy duty wood flatbeds
- Extra heavy duty wood flatbeds
- Extra heavy duty steel flatbeds
- Radio remote controls
- One-man or two-man baskets
- Hoist drum tensioner
- Continuous rotation
- Oil cooler
- Single front bumper outrigger
- Hydraulic hose reel
- Tool box
- Foot throttle
- Inching control for hoist operation at rear of subframe, for one man hook ball stowage and deploy

www.terexcranes.com

Effective Date: October 2010. Product specifications and prices are subject to change without notice or obligation. The photographs and/or drawings in this document are for illustrative purposes only. Refer to the appropriate Operator's Manual for instructions on the proper use of this equipment. Failure to follow the appropriate Operator's Manual when using our equipment or to otherwise act irresponsibly may result in serious injury or death. The only warranty applicable to our equipment is the standard written warranty applicable to the particular product and sale and Terex makes no other warranty, express or implied. Products and services listed may be trademarks, service marks or trade-names of Terex Corporation and/or its subsidiaries in the USA and other countries. All rights are reserved. Terex® is a registered trademark of Terex Corporation in the USA and many other countries. Copyright 2010 Terex Corporation..

Terex Cranes, Global Marketing, Dinglerstraße 24, 66482 Zweibrücken, Germany
Tel. +49 (0) 6332 830, Email: info.cranes@terex.com, www.terexcranes.com

Brochure Reference: TC-DS-I-E-BT 26106-10/10



WORKS FOR YOU.™