

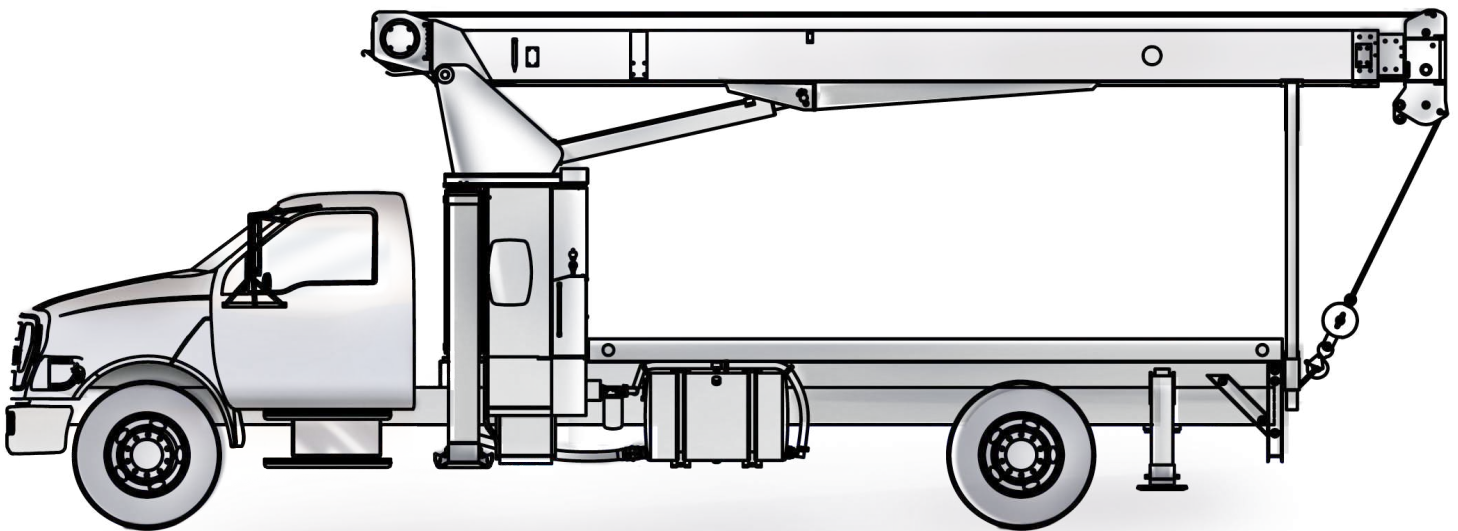

**BT 2057**  
**10 USt Lifting Capacity**  
**Boom Truck Crane**  
**Sales Flyer**  
**Imperial**

# BT 2057



## Highlights

The BT2057 from Terex combines strength, power and operational ease in a package that can be configured to meet your needs.

- ▶ 57 ft fully synchronous telescopic keel boom
- ▶ 10 USt maximum lifting capacity

## Applications

- ▶ Residential construction
- ▶ Roofing systems
- ▶ Equipment placement
- ▶ Transportation—Self-loading/unloading of materials
- ▶ Road work
- ▶ Rental services

**WORKS FOR YOU.™**

# SPECIFICATIONS

# BT 2057

## Features

<b>Maximum lifting capacity</b>	20,000 lb
<b>Main boom length</b>	57 ft
<b>Main boom and jib length</b>	93 ft

## Operational Ease

### Enhanced dual control console

Modular, dual-control console allows operation from either side of the machine.

### Precision control

Fully proportional controls with precise metering for smooth boom movements.

### Work area definition

The operator can define boundaries for boom rotation, lift and lower. A warning alarm sounds if the boom moves outside the defined area.

## Strength and Power

### Proven keel boom design

Three-section fully synchronized, self-centering design that optimizes strength and delivers performance for high lift capacities at all lift radii.

### High-performance hydraulics

Three-pump system simultaneously provides independent flow to the boom, hoist and slew drive.

### Outriggers

Heavy-duty outrigger system offers stability and a compact footprint.

## Dimensions

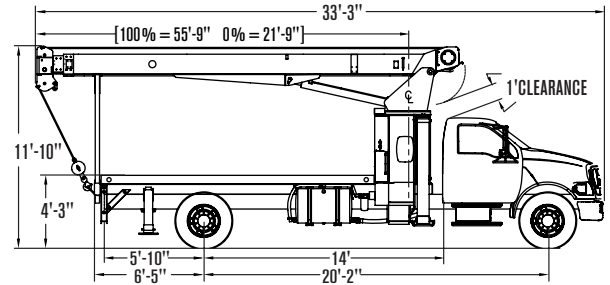

## Serviceability

### External rotation drive

External rotation drive provides easy maintenance access.

### Hoses

Hoses for extend/retract are easily accessible if maintenance is required.

## New and Improved

- Step-to-Deck™ enables easy control access
- Easily accessed
- Split guide rope guards
- Large capacity hydraulic reservoir improves oil cooling
- Work area definition

## Key Specifications

	Maximum sheave height with optional two-section jib	101 ft 9 in
	Maximum boom length with extension	79 ft with 22 ft one-section jib 93 ft with 36 ft two-section jib
	Maximum line pull	7,900 lb

## Optional Equipment

- Two-stage jibs
- Rotation resistant rope
- Multi-part load blocks
- Main hoist with 2-speed motor
- Heavy duty wood flatbeds
- Extra heavy duty wood flatbeds
- Extra heavy duty steel flatbeds
- Radio remote controls
- One-man or two-man baskets
- Hoist drum tensioner
- Continuous rotation
- Oil cooler
- Single front bumper outrigger
- Hydraulic hose reel
- Tool box

## Chassis Recommendations (see data sheet for more details)

Description	BT2057 (Single Axle)
Combined axle weight rating	33,000 lb
Front axle weight rating	12,000 lb
Rear axle weight rating	21,000 lb
Wheelbase	230 +/- 4 in
Cab to Axle	156 +/- 4 in
RBM per Frame Rail	1,200,000 lb/in



Effective Date: March 2012. Product specifications and prices are subject to change without notice or obligation. The photographs and/or drawings in this document are for illustrative purposes only. Refer to the appropriate Operator's Manual for instructions on the proper use of this equipment. Failure to follow the appropriate Operator's Manual when using our equipment or to otherwise act irresponsibly may result in serious injury or death. The only warranty applicable to our equipment is the standard written warranty applicable to the particular product and sale and Terex makes no other warranty, express or implied. Products and services listed may be trademarks, service marks or trade-names of Terex Corporation and/or its subsidiaries in the USA and other countries. All rights are reserved. Terex is a registered trademark of Terex Corporation in the USA and many other countries. Copyright 2012 Terex Corporation.

Terex Cranes, Global Marketing, Dingerstraße 24, 66482 Zweibrücken, Germany  
Tel. +49 (0) 6332 830, Email: info.cranes@terex.com, www.terexcranes.com

[www.terexcranes.com](http://www.terexcranes.com)

TC-SF-I-E-BT2057-03/12

Courtesy of Crane.Market