



TEREX

TB85/TB100/TB110

Telescopic Boom Lifts



FEATURES

- 85 ft. (25.91 m) to 110 ft. (33.53 m) maximum platform heights
- 550 lbs. (250 kg) and 500 lbs. (227 kg) maximum platform capacities
- Unique drive system provides excellent mobility
- 4-wheel drive system, extra high torque drive option
- Microprocessor controller for exceptional reliability and serviceability
- 10 ft. (3.0 m) articulating jib standard on TB110
- Quick change platform arrangement simplifies platform removal or replacement
- Power per your preference with engine options
- 5-year structural warranty, 1-year parts and labor warranty
- Terex Support Plus product service

simple, available and
cost effective™

Machines shown may have optional equipment.

Courtesy of Crane.Market

TEREX TB85 / TB100 / TB110 SPECIFICATIONS

Description	TB85	TB100	TB110
Height - Working (maximum)	91' (27.73 m)	106' (32.31 m)	116' (35.36 m)
Platform (maximum)	85' (25.91 m)	100' (30.48 m)	110' (33.53 m)
Stowed	9' 1" (2.84 m)	9' 0" (2.74 m)	9' 4" (2.85 m)
Length (stowed)	36' 9" (11.20 m)	34' 6" (10.52 m)	36' 3" (11.05 m)
Width (maximum)	8' 1-1/2" (2.48 m)	8' 1-1/2" (2.48 m)	8' (2.44 m)
Horizontal Reach	70' 0" (21.3 m)	67' 4" (20.52 m)	67' 0" (20.42 m)
Boom Angle - Above Horizontal	75°	75°	75° + 10° Articulating
Below Horizontal	-14°	-14°	-14° -105° Articulating
Std. Platform Dimensions	72" x 36" x 44" (1.83 m x 0.91 m x 1.12 m)	72" x 36" x 44" (1.83 m x 0.91 m x 1.12 m)	72" x 36" x 44" (1.83 m x 0.91 m x 1.12 m)
Load Capacity (maximum)	550 lbs. (250 kg)	500 lbs (227 kg)	500 lbs. (227 kg)
Opt. Platform Dimensions	96" x 36" x 44" (2.44 m x 0.91 m x 1.12 m)	96" x 36" x 44" (2.44 m x 0.91 m x 1.12 m)	N/A
Load Capacity (maximum)	500 lbs. (227 kg)	450 lbs. (204 kg)	N/A
Platform Rotation	160°	160°	160°
Wheelbase	12' 0" (3.66 m)	12' 0" (3.66 m)	12' 0" (3.66 m)
Wheel Track	6' 9" (2.06 m)	6' 9" (2.06 m)	6' 9" (2.06 m)
Turret Tailswing	35" (0.897 m)	35" (0.897 m)	35" (0.897 m)
Turret Rotation	360° Continuous	360° Continuous	360° Continuous
Turning Radius			
Inside Curb	22' 6" (6.86 m)	22' 6" (6.86 m)	22' 6" (6.86 m)
Travel Speed			
Stowed	0 - 3.0 mph (0 - 4.83 km/h)	0 - 3.0 mph (0 - 4.83 km/h)	0 - 3.0 mph (0 - 4.83 km/h)
Elevated	0 - 0.5 mph (0 - 0.8 km/h)	0 - 0.5 mph (0 - 0.8 km/h)	0 - 0.5 mph (0 - 0.8 km/h)
Gradeability*	35% (19.3 deg) - Std. 4WD	25% (14 deg) - Std. 4WD	25% (14 deg) - Std. 4WD
Controls			
Boom Functions	Proportional	Proportional	Proportional
Drive	Proportional	Proportional	Proportional
Power Source - Standard	Water-cooled diesel 76 hp (56.7 kw)	Water-cooled diesel 76 hp (56.7 kw)	Water-cooled diesel 76 hp (56.7 kw)
Optional Std. with XT Package (TB85 and TB100 only)	Water-cooled gasoline 66 hp (49.2 kw)	N/A	N/A
Optional	Air-cooled diesel 56 hp (41.7 kw)	Air-cooled diesel 56 hp (41.7 kw)	Air-cooled diesel 56 hp (41.7 kw)
Fuel Tank Capacity	40 gal. (151 L)	40 gal. (151 L)	40 gal. (151 L)
Hydraulic System	Load sensing pressure compensating	Load sensing pressure compensating	Load sensing pressure compensating
Reservoir Capacity	52 gal. (197 L)	52 gal. (197 L)	52 gal. (197 L)
Tires (monofilled)	15 x 19.5 13 P.R.	15 x 19.5 13 P.R.	15 x 19.5 13 P.R.
Ground Clearance	10.88" (0.28 m)	10.88" (0.28 m)	10.88" (0.28 m)
Approx. Shipping Weight	37,300 lbs. (16 919 kg)	39,300 lbs. (17 826 kg)	42,000 lbs. (19 051 kg)**

*Gradeability data is theoretical and is limited by tire slip, stability, or engine oil pan design. **Approximate weight

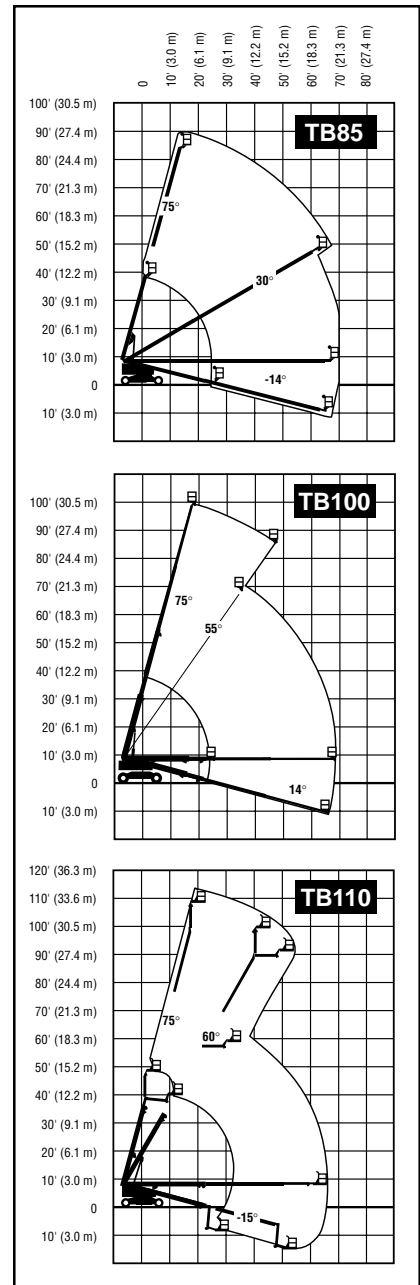

We reserve the right to amend these specifications at any time without notice. The only warranty applicable is our standard written warranty applicable to the particular product and sale. We make no other warranty, expressed or implied.

STANDARD FEATURES

- Choice of Cummins 4B3.9 - 76 hp (56.7 kw) water-cooled diesel engine, Deutz F4L1011 - 56 hp (41.7 kw) air-cooled diesel engine or Ford LRG425 66 hp (49.2 kw) water-cooled gasoline engine with dual fuel kit
- Four wheel drive
- Ultra high torque drive (Cummins engine only)
- All-steel, high strength booms
- All function auxiliary power
- Spring applied, hydraulically released parking brakes
- Swing gate
- Positive ignition start switch
- Infinitely variable proportional controls
- Energy efficient hydraulic system w/load sensing and pressure compensating capabilities
- Engine anti-restart system
- Automatic platform leveling
- 110 or 220 VAC wiring and GFI receptacle to platform
- Multi-axial slope sensor with alarm
- Fluid level indicators
- Auxiliary controls at ground level
- Quick change all steel work platform
- Recessed platform top rail
- Lanyard eyelets for safety harness attachment
- Guarded foot and hand controls with return to neutral feature
- Emergency all-power shut down switch on console
- Fully accessible hydraulic/electric componentry
- Monofilled tires
- Lifting lugs
- Hourmeter
- All motion alarm
- Flashing amber beacon
- Totally enclosed external power track (TB85 only)
- Articulating jib (TB110 only)
- Terex Support Plus product service

OPTIONS

- 8' (2.44 m) Universal platform (In place of standard 6' (1.83 m) – TB85 and TB100 only)
- Glass handling platform (In place of standard 6' (1.83 m) – TB85 and TB100 only)
- Compressed air line to platform – 1/2" (1.27 cm) with hose reel
- Hydraulic line to platform with hose reel
- Towing package (Includes tow bar) – Fixed axle machines only
- Hostile environment package
- 120V AC generator
- 220V AC generator
- Directional correcting controls
- Head or tail lights
- Spark arrester muffler (Standard on Cummins engine)
- Platform work light
- Engine block heater (Cummins engine)
- Lube oil heater (Cummins engine)
- Push button warning horn
- EC Compliance Package

For more information, product demonstration, or details on lease and rental plans, please contact your local Terex Aerials Distributor.

TEREX AERIALS

106 12th Street S.E.
Waverly, IA 50677-9466 USA
(319) 352-3920 • FAX: (319) 352-5727
E-mail: waverly@terexlifting.com

www.terexlift.com