



All Terrain Crane

ATF-1300XL

Maximum Lifting Capacity 130 Short-Ton





TADANO

ATF-1300XL

130 Ton Capacity (118.0 Metric Tons)

HYDRAULIC ALL TERRAIN CRANE

DIMENSIONS

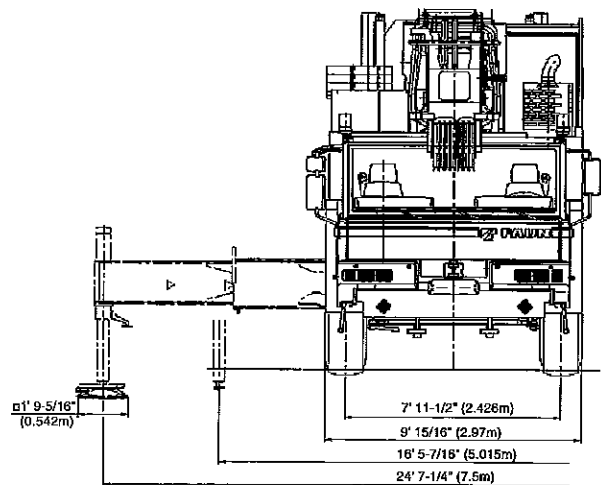
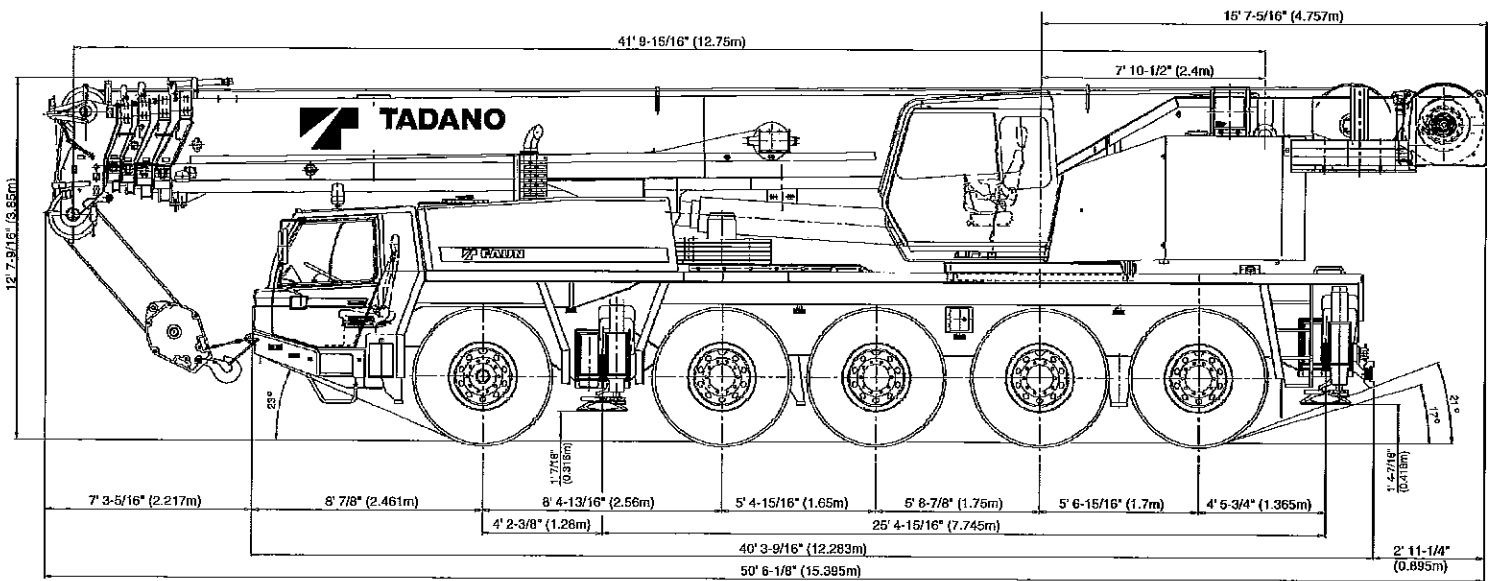

TURNING RADIUS

Steering	Front wheel (10x6)	All wheel (10x10)
Carrier inside	25' 3-1/8" (7.7m)	14' 1-5/16" (4.3m)
Over carrier	45' 3-5/16" (13.8m)	33' 5-9/16" (10.2m)
Over boom	48' 10-5/8" (14.9m)	37' 8-3/4" (11.5m)
Over boom extension	51' 2-3/16" (15.6m)	39' 8-3/8" (12.1m)
Wheel truck radius	40' 4-1/4" (12.3m)	28' 2-9/16" (8.6m)

Note : Dimension is with 20.5R25 Tires.

Specifications are subject to change without notice
Courtesy of CraneMarket

1. CRANE CARRIER

1.1 FRAME

FAUN purpose built, 5 axle, box-type, torsion resistant, welded construction made of high tensile steel with integrated outrigger housings. Equipped with front and rear fenders, front and rear towing and tie-down lugs and towing connections and access ladders.

1.2 OUTRIGGERS

Four point, fully hydraulic, double telescopic outriggers with horizontal and vertical motions are independently controlled by electro-magnetic valves. Push button controls with level gauges on both sides of carrier and in super-structure cab. Vertical cylinders with integral holding valves. Plastic floats can be stored on vertical cylinders or on carrier for road travel. Outrigger base: length 25' 4-15/16" (7.745m), width 24' 7-1/4" (7.5m), mid. Extension 16' 5-7/16" (5.015m).

1.3 CARRIER ENGINE

Mercedes Benz 8 cylinder water-cooled diesel engine, model OM 502 LA (EUROMOT,EURO 2,EPA), with hydrostatically driven fan and thermostatically controlled cooler. Displacement 972.04 in³, Rating 476 hp at 2,000 rpm: Torque 1,548 ft-lbs at 1,080 rpm.

1.4 TRANSMISSION

Allison automatic transmission HD 4560 P and hydrodynamic torque converter with "lock-up", 6 forward gears and 1 reverse gear.
Gear ratios: Forward: 4.70 / 2.21 / 1.63 / 1.00 / 0.76 / 0.67
Reverse: 5.55

1.5 TRANSFER

Two-stage transfer case Steyr VG 1600 with on/off road drive.
Gear ratios: On road: 0.89
Off road: 1.536

1.6 DRIVE

10x6 for on-road: 2nd, 4th and 5th axle are driven
10x8 for off-road: 2nd, 3rd, 4th and 5th axle are driven

1.7 AXLES

1st axle : steered, non-driven
2nd axle steered, driven with transverse differential lock, reduction : 9.72
3rd axle : steered, driven with transverse differential lock, reduction : 9.72
4th axle : steered, driven with transverse differential lock, reduction : 9.72, with integrated transfer case with reduction : 1.03
5th axle : steered, driven with transverse differential lock, reduction : 9.72

All steering knuckle bearings designed for minimum maintenance (yearly inspection).

1.8 SUSPENSION

Hydro-pneumatic, lockable with level adjustment. All axles have longitudinal and transverse trailing arms. With leveling adjustment and locked cylinders, the chassis can be tilted laterally and longitudinally by push buttons in the carrier cab which adjust the stroke of each individual suspension cylinder. All bearings are designed for minimum maintenance (yearly inspection).

Cylinder stroke: - 4-15/16" (- 126mm)
+ 5-13/16" (+ 148mm)

1.9 BRAKE SYSTEM

Service brake : Dual circuit compressed air system with air dryer.

Parking brake : Spring loaded type, acting on 3rd, 4th and 5th axles.

Auxiliary brake : Engine exhaust brake and constant throttle engine brake system.

1.10 WHEELS

(10) 17.00-25 steel disc wheels with (10) 20.5R25 on / off-road profile tires and mud flaps.
Carrier width 9' 8-15/16" (2.97m)

1.11 STEERING SYSTEM

ZF semi block dual circuit hydraulic steering, Mechanical steering of three front axles with hydraulic booster and a emergency steering pump is flange-mounted to the transfer box.

Rear axle steering mechanically locked in "centered" position. At slow speeds, rear axles can also be hydraulically steered independently from the front axles.

All bearings are designed for minimum maintenance (yearly inspection).

1.12 POWER TRAIN

Axles, suspension cylinders and drive-shafts with geared flanges virtually maintenance-free.

1.13 FUEL TANK CAPACITY

132 gal. filler cap lockable.

1.14 CARRIER CAB

Two man full width cab of composite structure (steel sheet metal and fiber glass), windshield of laminated safety glass with windshield wiper and washer, sliding side windows of hardened glass. Driver and co-driver seats adjustable and air-suspended with integrated 3 point safety belts and headrests. 2 rear-view mirrors (electrically adjustable), 1 wide angle mirror and additional curb mirror, all mirrors heated, Radio with cassette and connections for wireless. Engine dependent warm-water heater with defroster nozzles for windshield and cab floor. Instrumentation includes speedometer, odometer, tachograph, rpm counter with hour meter, fuel level gauge, air pressure gauge and engine warning lamp.

1.15 ELECTRICAL SYSTEM

24 volt DC system with 100 ampere 3-phase generator, and two 12 volt 170 Ah batteries.

Front lighting includes 2 main head lights, 2 high beam lights, 2 fog lights, 2 directional indicators and 2 parking lights.

Rear lighting includes 2 rear combi panels each with directional indicator, parking light, brake light, fog light, reversing light and license plate light.

Side lighting includes 2 front directional indicators and reflectors on carrier.

Other equipment includes hazard warning light system, cab light, instrument panel light, signal horn and amber rotating beacon on cab roof.

Lighting according to EEC regulations.

1.16 TOOLS AND ACCESSORIES

Special tool set, tire-inflation kit, warning triangle, hazard flashing lamp, fire extinguisher and first aid kit.

1.17 PAINTING

Standard TADANO colors

1.18 DIMENSIONS

Overall width : 9' 8-15/16" (2.97m) with tires 20.5R25

Overall height : 12' 7-9/16" (3.85m) with tires 20.5R25

In travel condition, the overall height can be adjusted - 4-15/16" / + 5-13/16"

Overall length : 50' 6-1/8" (15.395m) with Aux. winch

48' 11/16" (14.648m) without Aux. winch

Carrier length : 39' 4-1/4" (11.995m)

Wheel base : 8' 4-13/16" + 5' 4-15/16" + 5' 8-7/8" + 5' 6-15/16"
(2.56m + 1.65m + 1.75m +1.7m)

Tail swing : 16' 1/8" (4.88m) with Aux. winch

13' 3-1/4" (4.045m) without Aux. winch

1.19 CARRIER OPTIONAL EQUIPMENT

1. 14.00R25 on/off road profile tires-overall width 9' 1/4" (2.75m)

16.00R25 on/off road profile tires-overall width 9' 1/4" (2.75m)

2. Spare wheel and tire

3. Tool / tackle box at rear

4. 10 x 6 drive

5. Eddy current brake (retarder)

6. Pneumatic and electrical quick disconnect connectors mounted on rear bumper for boom dolly brakes and lights

2. TRAVEL PERFORMANCE (according to DIN 70020)

Max. travel speed : 49.7 mph

Min. travel speed in 1st gear at 800 rpm : 1.6 mph

Max. gradeability : 55 %

Acceleration from 0 to 31 mph : 29 sec.

Tires 20.5R25, Total GVW 132,200 lbs						
Gear	Travel speeds (mph) max. power				Gradeability (%) max. power	
	Normal gear		Off road gear		Normal gear	Off road gear
	0 - 6.8 (converter)	0 - 3.7 (converter)	0 - 3.7 (converter)	0 - 4.9 (lock up)	12.4 - 17.3 (converter)	22.3 - 34.1 (converter)
1st	0 - 8.0 (lock up)	0 - 4.9 (lock up)	0 - 3.7 (converter)	0 - 4.9 (lock up)	12.4 - 17.3 (converter)	22.3 - 34.1 (converter)
2nd	17.3 (lock up)	9.9 (lock up)	14.2 (lock up)	9.9 (lock up)	4.9 - 7.4 (converter)	9.9 - 13.6 (converter)
3rd	24.8 (lock up)	14.2 (lock up)	21.7 (lock up)	14.2 (lock up)	2.4 (lock up)	4.9 (lock up)
4th	37.9 (lock up)	21.7 (lock up)	29.2 (lock up)	21.7 (lock up)	1.2 (lock up)	2.7 (lock up)
5th	49.7 (lock up)	29.2 (lock up)	32.9 (lock up)	29.2 (lock up)	0.6 (converter)	1.8 (lock up)
6th	49.7 (lock up)	32.9 (lock up)	0 - 3.1 (converter)	32.9 (lock up)	0.4 (converter)	1.5 (lock up)
Rev.	0 - 5.5 (converter)	0 - 3.1 (converter)	0 - 3.1 (converter)	0 - 3.1 (converter)	21.1 (converter)	43.4 (converter)

The gradeability is based on theoretical values and depends on ground conditions and the coefficient of friction.

3. SUPERSTRUCTURE

3.1 SUPERSTRUCTURE FRAME

Connected to carrier by a single-row ball bearing slewing ring with external gearing providing 360° continuous rotation.

3.2 CRANE ENGINE

Mercedes Benz 4 cylinder water-cooled diesel engine, model OM 904 LA (EUROMOT, EURO 2, EPA), with 170 hp at 2,300 rpm. Stepless control of engine rpm by foot pedal. Engine pre-heat system. Fuel tank capacity : 79.2 gal (300 l)

3.3 HYDRAULIC SYSTEM

Three circuit diesel hydraulic system with 1 axial piston variable displacement (hydraulically controlled) double pump with cumulative control for telescoping, derricking and hoisting plus 1 double gear pump for swing and pilot controls. Hydraulic oil cooler.

3.4 HYDRAULIC CONTROLS

2 joy-stick levers and 4 three-way electrically operated valves for independent simultaneous operation of all crane motions with stepless speed control.

3.5 TELESCOPIC BOOM

Five section box type construction of high tensile steel, consisting of 1 base section and 4 telescopic sections. The boom is extended by means of 1 double acting single stage and 1 double acting two stage hydraulic cylinders with integrated holding valves and a rope-crowd extension system. Automatic locking of 1st telescope section controlled from crane cab. All telescope sections can be telescoped independently (telescope sections 3 and 4 synchronously) and under partial load.

Total retracted length : 41' 11-15/16" (12.8m)
Total extended length : 167' 3-7/8" (51.0m)
Max. sheave height : 177' 2" (54.0m)
Telescoping speed out : 200 sec. normal speed /
140 sec. high speed

3.6 TELESCOPIC BOOM EXTENSION

Swing around lattice type boom extension 31.1' / 53.1' (9.5m / 16.2m) with 5° / 20° / 40° offsets, consisting of a 31.1' (9.5m) lattice type base section and a 22' (6.7m) long lattice type extension which stores inside the base section. Equipped with anti-two block system. Additional lattice type stinger of 24.6' (7.5m) giving total extension length of 79.07' (24.1m). Additional lattice type intermediate section of 19.68' (6.0m) giving total extension length of 98.75' (30.1m).

3.7 AUXILIARY LIFTING SHEAVE (SINGLE TOP)

Single sheave mounted to main boom head for single line operation (stowable). Equipped with anti-two block system.

3.8 BOOM HOIST

1 double acting hydraulic cylinder with integral holding valve.
Boom elevation : -2° to +82°
Boom elevation speed : 86 sec. normal speed /
50 sec. high speed (only derricking up)

3.9 MAIN WINCH

Axial piston constant displacement motor, grooved hoist drum, integral planetary gear, automatic hydraulically controlled spring-loaded multiple disc brake and integral free wheeling (no sagging of load by hoisting). Winch drive assembly connected to open hydraulic system. Wire rope with "Superstop" easy reeving system. Lower limit switch and drum turn indicator.
Drum diameter : 20.67" (525mm)
Rope diameter : 0.83" (21mm)
Rope length : 820' (250m)
Max. line pull 1st layer : 20,457 lbs. (91 kN)
Max. line speed 4th layer : 236 ft/min (72m/min) normal/
419 ft/min (128m/min) high

3.10 AUXILIARY WINCH

Axial piston constant displacement motor, grooved hoist drum, integral planetary gear, automatic hydraulically controlled spring-loaded multiple disc brake and integral free wheeling (no sagging of load by hoisting). Winch drive assembly connected to open hydraulic system. Wire rope with "Superstop" easy reeving system. Lower limit switch and drum turn indicator.
Drum diameter : 20.67" (525mm)
Rope diameter : 0.83" (21mm)
Rope length : 820' (250m)
Max. line pull 1st layer : 20,457 lbs. (91 kN)
Max. line speed 4th layer : 236 ft/min (72m/min) normal/
419 ft/min (128m/min) high

3.11 SLEWING GEAR

Constant displacement motor with three stage planetary gear, a foot actuated service brake and a parking brake. Slewing speed infinitely variable: 0 - 1.5 rpm

3.12 COUNTERWEIGHT

Total 55,115 lbs, divisible, assembled and disassembled by hydraulic cylinders controlled from crane cab.
Tail swing : 16' 1/8" (4.88m) with Aux. winch
13' 3-1/4" (4.045m) without Aux. winch

3.13 SUPERSTRUCTURE CAB

Spacious all-steel 20° tiltable cab with sliding door, extra-large tinted glass windows, fold-out front window with windshield washer and wiper, fixed cab roof window with armoured glass and washer/wiper, sun visor, cab light, adjustable hydraulically cushioned seat with headrest, signal horn, radio with cassette, and connection for wireless (12 volt). Engine dependent warm-water heater with defroster nozzles for windshield and cab floor, plus additional diesel crane cab heater. Ergonomically positioned control elements and instrumentation for crane operation including fuel level gauge, engine cooling water temperature, hour meter and combined engine warning lamp. Travel controls for steering and driving in 1st forward and reverse gear only. Outrigger controls and level from superstructure cab.

3.14 ELECTRICAL SYSTEM

24 volt system with 30 A 3-phase alternator, two 12 V (110 Ah) batteries, 1 rotating beacon on right-hand side of main winch, 2 working lights on cab front flap, 1 working light on boom base section and 2 side lights on boom head.

3.15 SAFETY DEVICES

Electronic load moment device (PAT-PDC-System) with interpolation and automatic overload shut-off, hoist limit switch with shut-off, overload warning and load moment gauge. Digital display of boom angle, boom length, sheave height, working radius, hook load and further information. Safety valves against pipe and hose rupture, holding valves on hydraulic cylinders.

3.16 SUPERSTRUCTURE EQUIPMENT

8 ton headache ball
63 ton hook block, 3 sheaves, ram's horn hook

3.17 SUPERSTRUCTURE OPTIONAL EQUIPMENT

1. Free slewing and free boom elevation circuits for use with boom dolly.
2. 360° positive swing lock (NYC requirement).

ATF-1300XL WORKING RANGE CHART

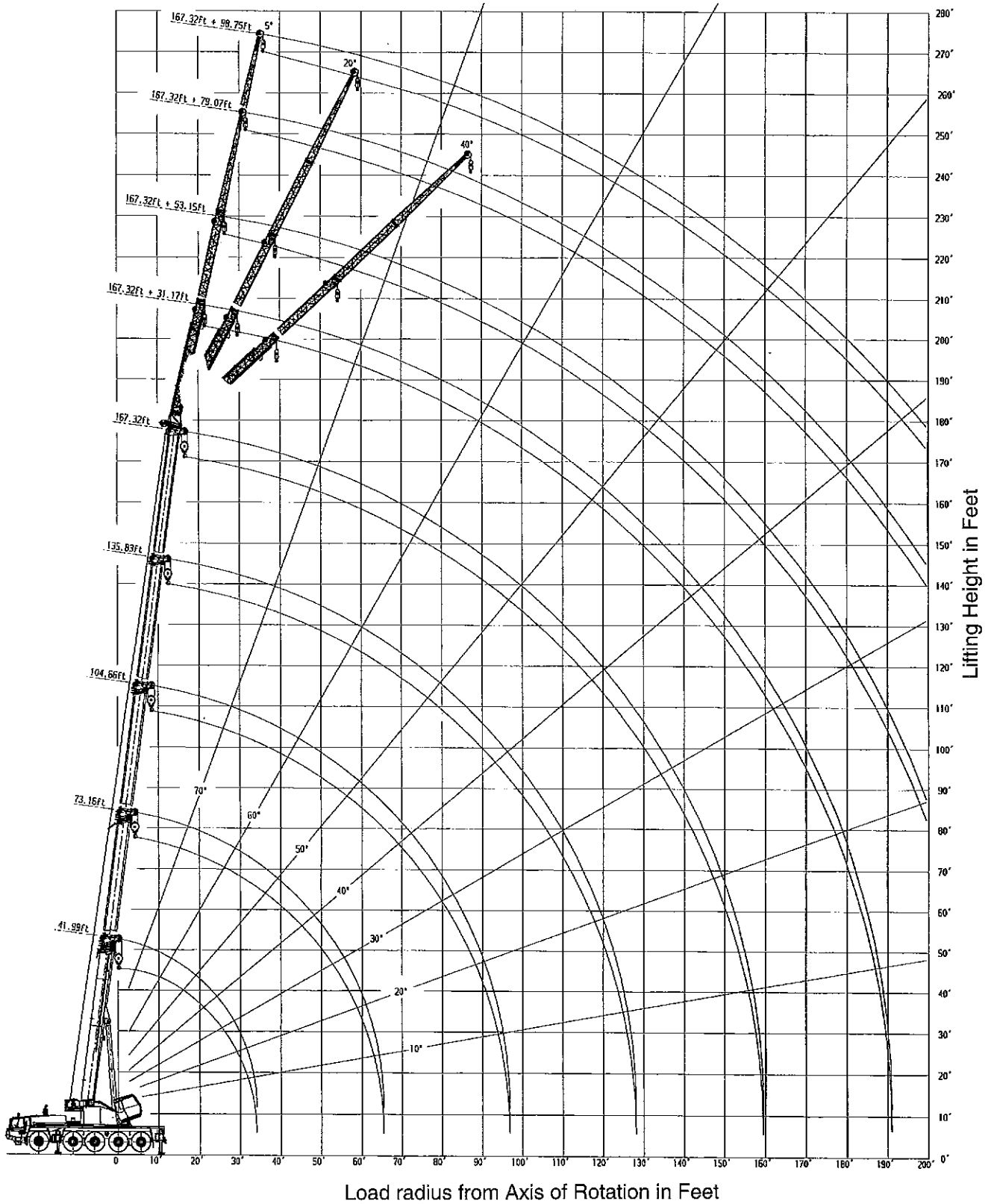

NOTE: Boom and jib geometry shown are for unloaded condition and machine standing level on firm supporting surface. Boom deflection and subsequent radius and boom angle change must be accounted for when applying load to hook.

Counterweight 30,864 lbs

Work. Radius (ft)	Lifting capacities in 1,000 lbs according per SAE J765 on telescopic boom																				Work. Radius (ft)
	On outriggers, 360° working area																				
	Outrigger base 24.61 ft																				
	Boom length (ft)																				
	41.99	57.41	73.16	73.16	73.16	88.91	88.91	104.66	104.66	104.66	120.41	135.83	135.83	135.83	151.57	151.57	167.32				
10	68	260.0	227.0	75	193.5															10	
12	65	219.5	192.0	72	187.5	77	111.5	77	145.5	77	48.5									12	
14	62	189.5	174.0	70	172.0	75	111.5	75	145.5	75	48.5	78	104.0	78	48.5					14	
16	59	165.5	159.5	68	157.0	73	111.5	73	145.5	73	48.5	77	104.0	77	48.5					16	
18	55	147.5	145.0	66	142.5	72	111.5	72	137.0	72	48.5	76	104.0	76	48.5	79	48.5	79	48.5	18	
20	51	131.0	131.0	64	128.0	71	111.0	71	126.0	71	48.5	75	104.0	75	48.5	78	48.5	78	48.5	20	
25	42	99.0	99.0	58	95.5	66	95.8	66	93.4	66	48.5	71	48.5	75	48.5	75	80.0	75	48.5	25	
30	28	71.2	71.2	51	67.9	62	68.4	62	66.0	62	48.5	68	66.8	68	48.5	72	48.5	72	48.5	30	
35				45	51.5	57	51.9	57	49.7	57	48.5	64	50.4	64	48.5	69	48.5	69	48.5	35	
40				37	40.7	51	40.9	51	38.9	51	46.0	60	39.5	60	46.1	66	45.7	66	47.5	40	
45				26	32.6	46	33.0	46	31.0	46	38.6	56	31.5	56	39.2	63	37.5	63	31.9	45	
50						40	26.7	40	24.6	40	32.5	52	25.2	52	33.1	60	31.2	60	25.6	50	
55								33	21.5	33	19.3	33	27.4	48	20.0	48	28.0	56	26.0	55	
60										24	17.0	24	14.8	24	23.0	43	15.7	43	23.8	60	
65														38	12.3	38	20.5	48	18.3	65	
70																31	9.5	31	17.6	70	
75																		23	7.1	75	
80																				80	
85																				85	
90																				90	
95																				95	
100																				100	
110																				110	
120																				120	
130																				130	

1) Over rear with superstructure pin engaged.
* With additional equipment.

Operation and maintenance of this machine must be in compliance with the information provided in the "Operation and Maintenance Manual" supplied with this machine.

99707761552

Counterweight 30,864 lbs

Work. Radius (ft)	Lifting capacities in 1,000 lbs according per SAE J765 on telescopic boom																				Work. Radius (ft)
	On outriggers, 360° working area																				
	Outrigger base 16.40 ft																				
	Boom length (ft)																				
	41.99	57.41	73.16	73.16	73.16	88.91	88.91	104.66	104.66	104.66	120.41	135.83	135.83	135.83	151.57	151.57	167.32				
10	68	188.0																		10	
12	65	167.0	75	184.5																12	
14	62	150.0	72	164.5	77	111.5	77	145.5	77	48.5										14	
16	59	130.0	70	147.5	75	111.5	75	142.5	75	48.5	78	104.0	78	48.5						16	
18	55	106.5	68	125.5	73	111.5	73	123.0	73	48.5	77	104.0	77	48.5						18	
20	51	84.1	66	101.5	72	99.1	72	99.1	72	48.5	76	92.7	76	48.5	79	48.5	79	48.5		20	
25	42	55.4	64	79.9	71	80.6	71	77.5	71	48.5	75	78.4	75	48.5	78	48.5	78	78.1	78	25	
30	28	40.1	58	51.8	66	52.2	66	49.7	66	48.5	71	50.5	71	48.5	75	51.0	75	48.5	77	30	
35			51	35.8	62	36.2	62	34.0	62	43.0	68	34.7	68	43.9	72	41.5	72	35.1	72	35	
40			45	26.1	57	26.5	57	24.5	57	32.8	64	25.0	64	33.6	69	31.2	69	25.4	69	40	
45			37	19.4	51	19.9	51	17.9	51	25.8	60	18.3	60	26.7	66	24.3	66	18.8	66	45	
50			26	14.6	46	14.8	46	13.0	46	20.6	56	13.5	56	21.3	63	19.2	63	13.9	63	50	
55					40	11.0	40	9.3	40	16.6	52	9.8	52	17.3	60	15.3	60	10.1	60	55	
60					33	8.0	33	6.2	33	13.4	48	8.8	48	14.1	56	12.1	56	7.0	56	60	
65					24	5.5	24	3.7	24	10.7	43	4.2	43	11.5	52	9.5	52	4.5	52	65	
70											38	2.2	38	9.3	48	7.3	48	2.5	48	70	
75																				75	
80																				80	
85																				85	
90																				90	
95																				95	
100																				100	

Operation and maintenance of this machine must be in compliance with the information provided in the "Operation and Maintenance Manual" supplied with this machine.

99707761553

Counterweight 0 lbs.

Work. Radius (ft)	Lifting capacities in 1,000 lbs. according per SAE J765 on telescopic boom On outriggers, 360° working area Outrigger base 24.61 ft																		Work. Radius (ft)			
	Boom length (ft)																					
	41.99	57.41	73.16	73.16	73.16	88.91	88.91	104.66	104.66	104.66	120.41	135.83	135.83	135.83	151.57	151.57	167.32					
10	68	207.5	75	193.5															10			
12	65	187.0	72	185.0	77	111.5	77	145.5	77	48.5									12			
14	62	167.0	70	164.5	75	111.5	75	145.5	75	48.5	78	104.0	78	48.5					14			
16	59	146.5	68	143.0	73	111.5	73	139.0	73	48.5	77	104.0	77	48.5					16			
18	55	125.0	66	120.5	72	106.5	72	118.0	72	48.5	76	102.0	76	48.5	79	48.5	79	80.0	79	48.5	18	
20	51	103.0	64	98.4	71	99.3	71	95.8	71	48.5	75	96.9	75	48.5	78	48.5	78	79.2	78	48.5	20	
25	42	65.2	58	61.4	66	61.9	66	59.1	66	48.5	71	59.8	71	48.5	75	48.5	75	60.5	75	48.5	25	
30	28	44.7	51	40.8	62	41.4	62	38.8	62	47.4	68	39.5	68	47.6	72	45.8	72	40.1	72	47.7	30	
35			45	28.5	57	29.1	57	26.5	57	36.1	64	27.2	64	37.2	69	34.5	69	27.7	69	37.9	35	
40			37	20.4	51	20.8	51	18.4	51	27.9	60	19.1	60	28.8	66	26.4	66	19.5	66	29.4	40	
45			26	14.4	46	14.8	46	12.6	46	21.9	56	13.2	56	22.7	63	20.3	63	13.7	63	23.4	45	
50					40	10.3	40	8.0	40	17.2	52	8.7	52	18.1	60	15.6	60	9.1	60	18.7	50	
55					33	6.6	33	4.4	33	13.4	48	5.1	48	14.3	56	11.8	56	5.5	56	14.9	55	
60					24	3.6	24	1.4	24	10.2	43	2.1	43	11.2	52	8.8	52	2.3	52	11.9	60	
65															38	8.7	48	6.3	48	9.3	65	
70															31	6.6	45	4.3	45	7.3	70	
75															23	4.9	40	2.7	40	5.5	75	
80															14	3.4	36	1.2	36	4.1	80	
85																				30	2.7	85
90																				23	1.7	90
95																						95
Telescoping sequence %																						
Tel. 1		0	50	50	100	0	100	0	50	100	0	100	50	100	0	100	50	100	Tel. 1			
Tel. 2		0	0	50	0	33	50	50	50	100	67	100	50	100	100	100	100	100	Tel. 2			
Tel. 3		0	0	0	0	33	0	50	50	0	67	25	100	50	100	75	100	100	Tel. 3			
Tel. 4		0	0	0	0	33	0	50	50	0	67	25	100	50	100	75	100	100	Tel. 4			
Code		080/180/280	180	180	080	280	080	280	180	080	280	080	180	080	280	080	180	080	Code			

Operation and maintenance of this machine must be in compliance with the information provided in the "Operation and Maintenance Manual" supplied with this machine.

99707761554

Counterweight 0 lbs.

Work. Radius (ft)	Lifting capacities in 1,000 lbs. according per SAE J765 on telescopic boom for rigging counterweight On outriggers, 360° working area Outrigger base 16.40 ft												Work. Radius (ft)
	Boom length (ft)												
	41.99	73.16											
10	68	179.0											10
12	65	151.0	77	48.5									12
14	62	106.5	75	48.5									14
16	59	75.9	73	48.5									16
18	55	59.0	72	48.5									18
20	51	45.0	71	47.6									20
25	42	26.9	66	33.1									25
30	28	16.7	62	22.2									30
35			57	15.6									35
40			51	11.0									40
45			46	7.7									45
50			40	5.1									50
55			33	3.0									55
60			24	1.2									60
Telescoping sequence %													
Tel. 1		0	0										Tel. 1
Tel. 2		0	33										Tel. 2
Tel. 3		0	33										Tel. 3
Tel. 4		0	33										Tel. 4
Code		999											Code

Operation and maintenance of this machine must be in compliance with the information provided in the "Operation and Maintenance Manual" supplied with this machine.

99707761563

Counterweight 47,178 lbs

Working Radius (ft)	Lifting capacities in 1,000 lbs according per SAE J765 on fly jib 31.17 ft / 53.15 ft / 79.07 ft / 98.75 ft															Working Radius (ft)					
	Boom length 41.99 ft to 151.57 ft					Boom length 151.57 ft to 167.32 ft					Boom length 41.99 ft to 167.32 ft										
	Fly jib 31.17 ft offset			Fly jib 31.17 ft offset			Fly jib 53.15 ft offset			Fly jib 79.07 ft offset			Fly jib 98.75 ft offset								
	5°	20°	40°	5°	20°	40°	5°	20°	40°	5°	20°	40°	5°	20°	40°						
35	80	22.0				81	17.0											35			
40	79	22.0	81	18.2		80	17.0	82	15.8									40			
45	78	22.0	80	18.2		79	17.0	81	15.8									45			
50	77	21.6	79	17.7	80	12.6	78	17.0	80	15.8								50			
55	75	21.0	77	17.0	78	12.4	77	17.0	79	15.8	80	12.7	79	12.1	82	10.1		55			
60	74	20.4	76	16.3	77	12.1	76	16.9	78	15.7	79	12.4	78	12.1	81	10.1		60			
65	73	19.9	74	15.6	75	11.8	75	16.7	76	15.5	77	12.1	77	11.9	79	9.9		65			
70	72	19.4	73	15.0	74	11.5	74	16.4	75	15.1	76	11.8	76	11.8	78	9.8	81	7.3	70		
75	70	17.9	71	14.4	72	11.2	72	16.1	73	14.8	74	11.5	75	11.5	77	9.5	79	7.2	75		
80	68	15.6	69	14.0	71	11.0	71	15.5	72	14.6	73	11.2	74	11.3	76	9.2	78	7.0	80		
85	66	13.5	67	13.4	69	10.7	69	13.9	70	14.1	71	11.0	72	11.1	74	8.7	76	6.8	85		
90	64	11.6	66	12.3	67	10.5	68	12.0	69	12.8	70	10.8	71	10.9	73	8.5	75	6.6	90		
95	62	10.0	64	10.9	65	10.3	66	10.5	67	11.4	68	10.6	70	10.5	72	8.2	74	6.5	95		
100	60	8.5	62	9.4	63	9.8	64	9.0	66	9.9	67	10.2	69	10.0	71	7.9	73	6.3	100		
110	56	6.0	58	6.7	59	7.3	60	6.4	62	7.2	63	7.8	65	8.3	67	7.4	69	6.1	110		
120	51	3.9	53	4.5	54	4.9	55	4.4	58	4.9	59	5.6	62	6.2	64	6.8	66	5.9	120		
130	47	2.2	48	2.6	49	2.9	52	2.6	54	3.1	55	3.6	59	4.5	61	5.3	63	5.7	130		
140					44	1.2	48	1.1	49	1.7	50	1.9	55	3.0	57	3.8	59	4.5	140		
150													51	1.7	53	2.3	55	2.9	150		
160															49	1.1	50	1.5	160		
170																	58	1.6	170		
180																	54	1.5	180		
190																		57	2.3	190	
																			56	1.1	190
Telescoping sequence %																					
Tel. 1	100					100					100					Tel. 1					
Tel. 2	100					100					100					Tel. 2					
Tel. 3	75					100					100					Tel. 3					
Tel. 4	75					100					100					Tel. 4					
Code	420	421	422	420	421	422	520	521	522	620	621	622	720	721	722	Code					

Operation and maintenance of this machine must be in compliance with the information provided in the "Operation and Maintenance Manual" supplied with this machine. 99707761557

Counterweight 47,178 lbs

Working Radius (ft)	Lifting capacities in 1,000 lbs according per SAE J765 on fly jib 31.17 ft / 53.15 ft / 79.07 ft / 98.75 ft															Working Radius (ft)							
	Boom length 41.99 ft to 151.57 ft					Boom length 151.57 ft to 167.32 ft					Boom length 41.99 ft to 167.32 ft												
	Fly jib 31.17 ft offset			Fly jib 31.17 ft offset			Fly jib 53.15 ft offset			Fly jib 79.07 ft offset			Fly jib 98.75 ft offset										
	5°	20°	40°	5°	20°	40°	5°	20°	40°	5°	20°	40°	5°	20°	40°								
35	80	22.0				81	17.0													35			
40	79	22.0	81	18.2		80	17.0	82	15.8											40			
45	78	22.0	80	18.2		79	17.0	81	15.8											45			
50	77	20.6	79	17.7	80	12.6	78	17.0	80	15.8										50			
55	75	18.0	77	17.0	78	12.4	77	16.5	79	15.8	80	12.7	79	12.1	82	10.1				55			
60	74	14.8	76	16.0	77	12.1	76	15.3	78	15.5	79	12.4	78	12.1	81	10.1				60			
65	73	12.1	74	13.5	75	11.8	75	12.6	76	13.9	77	12.1	77	11.9	79	9.9				65			
70	72	10.0	73	11.3	74	11.5	74	10.4	75	11.8	76	11.8	76	11.5	78	9.8	81	7.3	78	7.8	70		
75	70	8.1	71	9.3	72	10.4	72	8.5	73	9.8	74	10.8	75	10.4	77	9.5	79	7.2	77	7.5	75		
80	68	6.5	69	7.6	71	8.6	71	6.9	72	8.0	73	9.2	74	8.7	76	9.2	78	7.0	76	7.3	80		
85	66	5.0	67	6.0	69	7.0	69	5.5	70	6.5	71	7.5	72	7.3	74	8.7	76	6.8	75	7.1	85		
90	64	3.9	66	4.8	67	5.6	68	4.3	69	5.2	70	6.1	71	6.0	73	7.5	75	6.6	74	6.7	90		
95	62	2.8	64	3.6	65	4.3	66	3.2	67	4.1	68	4.9	70	4.9	72	6.3	74	6.5	73	6.0	95		
100	60	1.8	62	2.5	63	3.2	64	2.2	66	3.0	67	3.7	69	3.9	71	5.2	73	6.2	72	5.0	100		
110					59	1.3			62	1.2	63	1.8	65	2.2	67	3.3	69	4.5	69	3.2	110		
120													64	1.7	66	2.8	67	1.8	69	3.3	120		
130															63	1.3			66	1.9	130		
140																			66	1.9	140		
150																			67	1.9	150		
																					69	1.9	150
Telescoping sequence %																							
Tel. 1	100					100					100					Tel. 1							
Tel. 2	100					100					100					Tel. 2							
Tel. 3	75					100					100					Tel. 3							
Tel. 4	75					100					100					Tel. 4							
Code	423	424	425	423	424	425	523	524	525	623	624	625	723	724	725	Code							

Operation and maintenance of this machine must be in compliance with the information provided in the "Operation and Maintenance Manual" supplied with this machine. 99707761558

Counterweight 0 lbs

Working Radius (ft)	Lifting capacities in 1,000 lbs according per SAE J765 on fly jib 31.17 ft / 53.15 ft On outriggers, 360° working area Outrigger base 24.61 ft															Working Radius (ft)				
	Boom length 41.99 ft to 151.57 ft					Boom length 151.57 ft to 167.32 ft					Boom length 41.99 ft to 167.32 ft									
	Fly jib 31.17 ft offset			Fly jib 31.17 ft offset			Fly jib 53.15 ft offset													
	5°	20°	40°	5°	20°	40°	5°	20°	40°											
35	80	22.0				81	17.0													35
40	79	21.9	81	18.2		80	17.0	82	15.8											40
45	78	20.9	80	18.2		79	17.0	81	15.8											45
50	77	17.0	79	17.6	80	12.6	78	16.0	80	15.8				80	12.1					50
55	75	13.1	77	15.4	78	12.4	77	13.7	79	14.7	80	12.7	79	12.1	82	10.1				55
60	74	10.0	76	11.9	77	11.9	76	10.5	78	12.4	79	12.2	78	11.8	81	10.1				60
65	73	7.4	74	9.2	75	10.7	75	7.9	76	9.7	77	11.2	77	10.1	79	9.9				65
70	72	5.3	73	6.9	74	8.5	74	5.8	75	7.4	76	9.0	76	8.1	78	9.7	81	7.3		70
75	70	3.5	71	5.0	72	6.4	72	4.0	73	5.4	74	7.0	75	6.2	77	8.5	79	7.2		75
80	68	1.8	69	3.3	71	4.6	71	2.3	72	3.7	73	5.1	74	4.6	76	6.8	78	7.0		80
85			67	1.7	69	3.0			70	2.3	71	3.5	72	3.3	74	5.2	76	6.8		85
90					67	1.4					70	2.2	71	2.0	73	3.9	75	5.7		90
95															72	2.7	74	4.4		95
100															71	1.6	73	3.3		100
110																69	1.1			110
Telescoping sequence %																				
Tel. 1	100															Tel. 1				
Tel. 2	100															Tel. 2				
Tel. 3	75															Tel. 3				
Tel. 4	75															Tel. 4				
Code	480	481	482	480	481	482	580	581	582											Code

Operation and maintenance of this machine must be in compliance with the information provided in the "Operation and Maintenance Manual" supplied with this machine. 99707761561

WARNING AND OPERATING INSTRUCTIONS FOR LIFTING CAPACITIES

GENERAL

- Total rated loads shown on the TADANO LOAD RATING CHART apply only to the machine as originally manufactured and normally equipped by TADANO. Modifications to the machine or use of optional equipment other than that specified can result in a reduction of capacity.
- Construction equipment can be dangerous if improperly operated or maintained. Operation and maintenance of this machine must be in compliance with the information in the operation, safety and maintenance manual supplied with the machine. If this manual is missing, order replacement through the distributor.
- The operator and other personnel associated with this machine shall fully acquaint themselves with the latest applicable American National Standards Institute (ANSI) safety standards for cranes.

SET UP

- Total rated loads shown on the TADANO LOAD RATING CHART are the maximum allowable crane capacities and are based on the machine standing level on firm supporting surface under ideal job conditions. Depending on the nature of the supporting surface, it may be necessary to have structural supports under the outrigger floats to spread the load to a larger bearing surface.
- For on outrigger operation, outriggers shall be extended to the dimension according to the TADANO LOAD RATING CHART and secured by pins with tires free of supporting surface, before operating crane.
- Working on tires and traveling with load is not allowed.
- The weight of the auxiliary winch with 2,425 lbs. is taken into account as a part of counterweight. Therefore the auxiliary winch must be attached always at the superstructure for crane operation.

OPERATION

- Total rated loads with outriggers fully extended do not exceed 85% of the tipping loads. Total rated loads with outriggers half extended are determined from the formula: total rated load = (tipping load - 0,1 tip reaction) / 1.25.
- The crane's structural steelwork is in accordance with DIN 15018, part 3. Design and construction of the crane comply with DIN 15018, part 2 and with F.E.M. regulations.
- Total rated loads above the bold lines in the TADANO LOAD RATING CHART are based on crane strength and those below the bold lines on crane stability.
- The weight of load handling devices such as hook blocks, slings, etc., must be considered as part of the load and must be deducted from lifting capacities.

Hookball/ Hookblock(ton)	8.8	27.5	69.5					88			138					
No. of parts of line	1	2	3	4	5	6	7	8	9	10	11	12	13	14	15	
Max. lifting capacity (ton)	8.8	18.7	27.5	37	46	54.9	63.7	72.4	81	88	97.9	106.2	114.4	122.5	130	
Weight (lbs.)	440	660		1,370					1,765			3,310				

- Total rated loads are based on freely suspended loads and make no allowance for such factors as the effect of wind, sudden stopping of loads, supporting surface conditions, operating speeds, side loads, etc. Side pull on boom or jib is extremely dangerous.
- Total rated loads do not account for wind on lifted load or boom. Total rated loads and boom length shall be appropriately reduced, when wind velocity is above 18 mph (26 ft/sec.) for main boom operation and above 11 mph (16 ft/sec.) for jib operation.
- Total rated loads at load radius shall not be exceeded. Do not tip the crane to determine allowable loads.

- Do not operate at boom lengths beyond radius or boom angles where no capacities are shown. Crane may overturn without any load on the hook.
- Slewing of the superstructure is admissible only when the crane is supported on half or fully extended outriggers.
- The lifting capacity ratings specified in the TADANO LOAD RATING CHART apply to the telescopic boom without extendible fly jib fixed in transport position or working position. If the extendible fly jib is secured to the telescopic boom in transport position or working position, the lifting capacities of the telescopic boom are reduced by the values specified below. The weight of the extendible fly jib(3,650 lbs) is detected in terms of a load, and the load moment limiter will shut off earlier.

Load rating reduction for the telescopic boom with mounted fly jib									
Position of the fly jib	Boom length (ft)								
	41.99	57.41	73.16	88.91	104.65	120.41	135.83	151.57	167.32
Load rating reduction (ton)									
31.17/53.15' fly jib, mounted in transport position	0.66	0.29	0.29	0.19	0.19	0.14	0.14	0.12	0.11
31.17' fly jib, mounted to the boom head	2.59	2.12	1.94	1.84	1.8	1.73	1.7	1.68	1.61
53.15' fly jib, mounted to the boom head	3.2	2.59	2.24	2.07	2.02	1.89	1.85	1.78	1.71
79.09' fly jib, mounted to the boom head	5.18	3.77	3.23	2.94	2.87	2.63	2.63	2.44	2.32
98.75' fly jib, mounted to the boom head	7.06	4.99	4.3	3.78	3.67	3.33	3.33	3.11	2.88

- When making lifts at a load radius not shown, use the next longer radius to determine allowable capacity.
- Load per part line should not exceed 18,650 lbs. for the main winch and for the auxiliary winch.
- Loaded boom angles are approximate. The boom angle before loading should be greater to account for deflection.
- The 41.99 ft boom length capacities are based on the telescopic boom being fully retracted. If not fully retracted (less than 57.41 ft boom length), use the total rated loads for the 57.41 ft boom length according to the telescoping sequence.
- Extension or retraction of the telescopic boom with loads may be attempted within the limits of the TADANO LOAD RATING CHART. The ability to telescope loads is limited by hydraulic pressure, boom angle, boom length, crane maintenance, etc.
- When erecting or stowing the extendible fly jib, be sure to retain it by hand or by other means to prevent its free movement.
- Use the Anti-Two Block (OVERWIND CUTOUT) disable switch when erecting or stowing the extendible fly jib and stowing the hook block. While the switch is pushed, the hoist will not stop, even when an overwind condition occurs.
- The working radius specified in the TADANO LOAD RATING CHARTS for the extendible fly jib apply only if the telescopic boom is extended according to the TADANO LOAD RATING CHARTS. If one or more elements of the telescopic boom are retracted partially or completely, the specified boom angles will be decisive in determining total rated lifting capacities.
- When lifting a load by using the extendible fly jib (auxiliary hoist) and telescopic boom (main hoist) simultaneously, do the following:
 - Select the correct program for the load moment device in accordance with jib length, jib offset angle, counterweight and outrigger base.
 - Before starting the operation, make sure that the weight of the load is within the total rated load for the extendible fly jib.

MEMO

- 20. Safe Load Indicator (S.L.I.)
Before working with the telescopic boom or extendible fly jib, make sure that the S.L.I. code is set according to the desired telescoping sequence while the telescopic boom is completely retracted. A change of the telescoping sequence is not permissible when the boom has been partially or fully extended. In order to change the S.L.I. code number, the boom must be fully retracted.
- 21. Safe Load Indicator Program for Rigging Counterweight
After setting the S.L.I. code 999, the S.L.I. rigging program is activated for lifting the counterweight parts from a trailer or from the ground. This rigging program is based on half extended outriggers (= 16.40 ft), on a minimum counterweight of 0 lbs and up to a maximum boom length of 73.16 ft with extendible fly jib fixed in transport position. Therefore all parts of counterweight can be lifted by the crane on itself and placed on the carrier for rigging the counterweight.
- 22. Working with Single Top
Operation with the single top is allowed with the main winch and the auxiliary winch (2nd winch). The maximum allowed capacity is limited by the selected S.L.I. code für main boom operation according to existing counterweight and outrigger base at one side and by the single line pull which is limited by hydraulic pressure at the other side.
For operations with the single top mounted, use the TADANO LOAD RATING CHART for the telescopic boom in accordance with existing counterweight and outrigger base to find the total rated lifting capacity and also select the correct S.L.I. code for the telescopic boom in accordance with the existing counterweight and outrigger base. Find the total rated lifting capacity based on boom length and working radius. From that value, subtract 1,100 lbs and the weights of all lifting equipment used including hook block, sling and other auxiliary lifting devices. The result ($\text{total rated lifting capacity} - 1,100 \text{ lbs} - \text{lifting equipment}$) is the total rated lifting capacity for a single top lift.

DEFINITIONS

- 1. Working Radius: Horizontal distance from a projection of the axis of rotation to supporting surface before loading to the center of the vertical hoist line or tackle with load applied. The deflection of the boom due to its deadweight and the rated load are taken into account.
- 2. Loaded Boom Angle: The angle between the boom base section and the horizontal, after lifting the total rated load at the working radius.
- 3. Working Area: Area measured in a circular arc about the centerline of rotation.
- 4. Freely Suspended Load: Load hanging free with no direct external force applied except by the hoist line.
- 5. Side Load: Horizontal side force applied to the lifted load either on the ground or in the air.

Safe Load Indicator (PAT PDC 350)

The Safe Load Indicator (PAT PDC 350) is intended as an aid to the operator. Under no condition should it be relied upon to replace use of Load Rating Charts and Operating Instructions. Sole reliance upon the Safe Load Indicator Aids in place of good operating practice can cause an accident. The operator must exercise caution to assure safety.

TADANO AMERICA CORPORATION
4300 CAMPBELL ROAD, HOUSTON, TEXAS 77041-9116
U.S.A.
PHONE: (713) 895-9400 EXT.315
FAX: (713) 895-0352
<http://www.tadano-cranes.com/>

Form No. TAC-ATF-1300XL-01-001106-JK
