

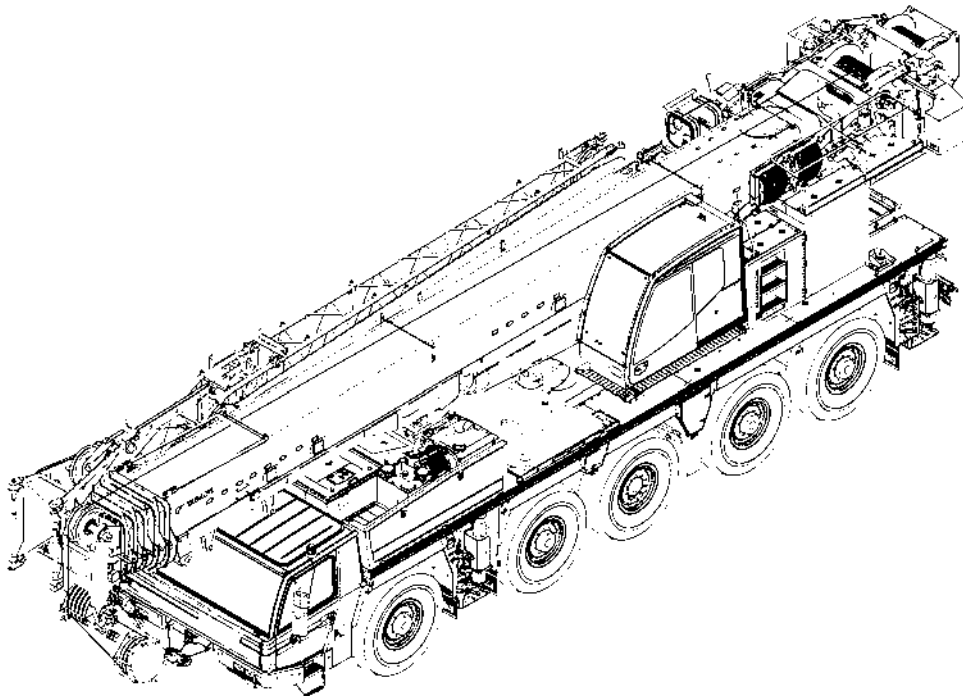

Translation of the original Operating Manual

# ATF 130G-5

Superstructure



11509

Vehicle identification number WFN5RUNMXE2146097

## Head Office

**TADANO LTD.**

ko-34

Takamatsu

Phone: +81-87-839-5555

Fax: +81-87-839-5743

## Overseas Service Dept

**TADANO LTD.**

Tadano Ryogoku Bldg.

Tokio, Japan

Phone: +81-3-3621-7765

Fax: +81-3-3621-7785



# Table of Contents

<b>1</b>	<b>Preface</b>	<b>9</b>
1.1	Superstructure Model Plate	9
1.2	In case of Damage	9
1.3	Warranty	9
1.4	Structure of the Operating Manual	10
1.5	Using the Operating Manual	10
1.5.1	Symbol and warning labels	11
1.5.2	Definition of the direction specifications	12
<b>2</b>	<b>General safety instructions</b>	<b>13</b>
2.1	<b>Basic Safety Information</b>	<b>13</b>
2.1.1	Use of the Mobile Crane	13
2.1.2	Personnel Requirements	14
2.1.3	Planning Use	17
2.1.4	Outrigger	21
2.1.5	Servicing and Maintenance	24
2.1.6	Welding and alignment work	26
2.1.7	Risk of fire and explosion	27
2.1.8	Different lengths of the hydraulic cylinders	27
2.1.9	Dismounting and disposal	28
2.2	<b>Basic Safety Information for the Superstructure</b>	<b>29</b>
2.2.1	Warning and Instruction Signs	29
2.2.2	Before Operating the Crane	38
2.2.3	Safety equipment	39
2.2.4	Crane operation with load	42
2.2.5	Errors during Crane Work	61
2.2.6	Ending Crane Work	62
<b>3</b>	<b>Operation</b>	<b>65</b>
3.1	<b>Crane components of superstructure</b>	<b>65</b>
3.1.1	Assemblies, components – installation place	65
3.1.2	Crane cab	66
3.1.3	Operating elements	68
3.2	<b>Before starting work</b>	<b>71</b>
3.2.1	Checking the lights	71
3.2.2	Checking the oil level	72
3.2.3	Checking the coolant level	72
3.2.4	Checking the fill quantity of fuel	72
3.2.5	Cleaning windshields	73
3.2.6	Checking the hoisting rope	73

## Table of Contents

---

3.2.7	Checking the bottom block	73
<b>3.3</b>	<b>Crane cab</b>	<b>73</b>
3.3.1	Cab door	73
3.3.2	Step adjustment	75
3.3.3	Opening/closing the window	76
3.3.4	Adjusting the seat	78
3.3.5	Heater, ventilation, air conditioning system	82
3.3.6	Interior lighting	83
3.3.7	Roller sun visor	83
3.3.8	Sun visor	84
3.3.9	Radio	84
3.3.10	Ventilator*)	84
<b>3.4</b>	<b>Control &amp; Service System CSS</b>	<b>85</b>
3.4.1	Main screen	85
3.4.2	Selection menu	89
<b>3.5</b>	<b>Automatic safe load indicator</b>	<b>96</b>
3.5.1	Notes regarding the lifting capacity charts and supporting force tables	96
3.5.2	Control panel and displays	97
3.5.3	Entering the operating conditions	105
3.5.4	Operating the telescopic boom	112
3.5.5	Safety working range	117
3.5.6	Test function	122
3.5.7	Special functions	122
3.5.8	Lift adjuster	128
3.5.9	Warnings and error codes	130
<b>3.6</b>	<b>Other safety devices</b>	<b>156</b>
3.6.1	Anti-twoblock device	156
3.6.2	Overriding the automatic safe load indicator	157
3.6.3	Lower limit switch	158
3.6.4	Anemometer	160
3.6.5	Aircraft warning lamp*)	162
<b>3.7</b>	<b>Commissioning</b>	<b>162</b>
3.7.1	Measures and checks before commissioning	162
3.7.2	Electrical system	164
3.7.3	Starting/stopping the engine	168
3.7.4	Monitoring the display, indicator and warning lamps as well as the instruments when the engine is running	171
3.7.5	Central lubricating system	175
3.7.6	Filling up with diesel or AdBlue®	176
<b>3.8</b>	<b>Outrigger</b>	<b>179</b>
3.8.1	Preparations	179
3.8.2	Outrigger	188
<b>3.9</b>	<b>Functions of control levers and pedals</b>	<b>195</b>
3.9.1	Instructions for actuating the crane control levers	195



3.9.2	Superstructure lock	198
3.9.3	Swing mechanism lock*)	200
3.9.4	Overriding the slew/derrick slow-stop function	202
3.9.5	Assigning the crane control levers	204
<b>3.10</b>	<b>Rigging and dismantling</b>	<b>225</b>
3.10.1	Counterweights	225
3.10.2	Jib*)	253
3.10.3	Lifting work	396
3.10.4	Hook tackle/bottom block	403
3.10.5	Bottom block holder*)	403
3.10.6	Single top	405
3.10.7	Removing the second hoisting gear, mounting the balancing counterweight	407
3.10.8	Two-hook operation	409
<b>3.11</b>	<b>Crane operation with load</b>	<b>412</b>
3.11.1	Influence of the temperature difference in case of heating of the boom due to solar radiation	412
3.11.2	Crane operation on outriggers	413
3.11.3	Crane operations on wheels	415
<b>3.12</b>	<b>Ladders, access steps, railing</b>	<b>416</b>
3.12.1	Double ladder	417
<b>3.13</b>	<b>Add-on parts, special and ancillary equipment</b>	<b>421</b>
3.13.1	Hourmeter for hoisting gear 1	421
3.13.2	Hourmeter for hoisting gear 2	422
3.13.3	Observation mirror of hoisting gear 1	422
3.13.4	Observation mirror of hoisting gear 2	423
3.13.5	Charging socket and plugbox for starting via an external power source	424
3.13.6	Load view camera*)	425
3.13.7	Amot Control (engine stop)	426
<b>3.14</b>	<b>Winter operation</b>	<b>427</b>
3.14.1	Engine	428
3.14.2	Hydraulic system	430
3.14.3	Windshield washing system	431
<b>3.15</b>	<b>Operation in case of an emergency</b>	<b>431</b>
3.15.1	Crane control	432
3.15.2	Failure of components or central unit of the safe load indicator	434
3.15.3	Resetting telescope manually	436
3.15.4	Slewing the superstructure	445
3.15.5	Counterweight	447
3.15.6	Drive unit	449
3.15.7	Emergency stop switch for the superstructure	454
3.15.8	Starting the superstructure engine using external current	454
3.15.9	Emergency exit	458
3.15.10	Superstructure emergency stop pushbutton	459
3.15.11	Emergency control/emergency release*)	459

<b>4</b>	<b>Crane testing instructions</b>	<b>467</b>
4.1	Periodic tests of cranes	467
4.2	Checking the load-bearing steel structures	467
4.2.1	Measures to protect electronic parts during welding	468
4.2.2	Indicators for the points to be checked	470
4.3	Checking the bottom block	475
4.4	Checking the hoisting ropes	477
4.4.1	Replacement state of hoisting ropes	478
4.4.2	Replacing a hoisting rope	481
4.4.3	Maintenance and repair of the hoisting rope	482
4.5	Service life of the hoisting gear	483
4.6	Monitoring the slewing ring	483
4.6.1	Checking the turntable fixing screws	483
<b>5</b>	<b>Rectifying the faults</b>	<b>485</b>
5.1	Rectifying the faults	485
5.1.1	Engine	486
5.1.2	Superstructure hydraulic system - general	487
5.1.3	Swing mechanism	488
5.1.4	Telescoping system	488
5.1.5	Derrick	489
5.1.6	Hoisting gear	489
5.1.7	Counterweight	490
5.1.8	Electrical system	490
5.1.9	Wiring diagram	491
<b>6</b>	<b>Technical Specifications</b>	<b>495</b>
6.1	Engine	495
6.2	Hydraulic system	495
6.3	Hoisting gear	496
6.4	Telescopic boom	496
6.5	Boom luffing gear	496
6.6	Swing mechanism	496
6.7	Safety equipment	497
6.8	Electrical system	497
6.9	Superstructure cab	497
6.10	Counterweight	498
6.11	Superstructure frame	499
6.12	Optional equipment	500

<b>7</b>	<b>Service and Maintenance</b>	<b>501</b>
<b>8</b>	<b>Annex/Manufacturer's documents</b>	<b>587</b>
<b>8.1</b>	<b>Central lubricating system</b>	<b>587</b>
8.1.1	Overview of lubrication points	587
<b>8.2</b>	<b>Superstructure cab</b>	<b>601</b>
<b>8.3</b>	<b>MTU Tier4i-Inducement-Concept</b>	<b>613</b>
<b>8.4</b>	<b>Dolly traveling operation</b>	<b>621</b>
<b>8.5</b>	<b>Fall protection system</b>	<b>631</b>



## 1 Preface

### 1.1 Superstructure Model Plate

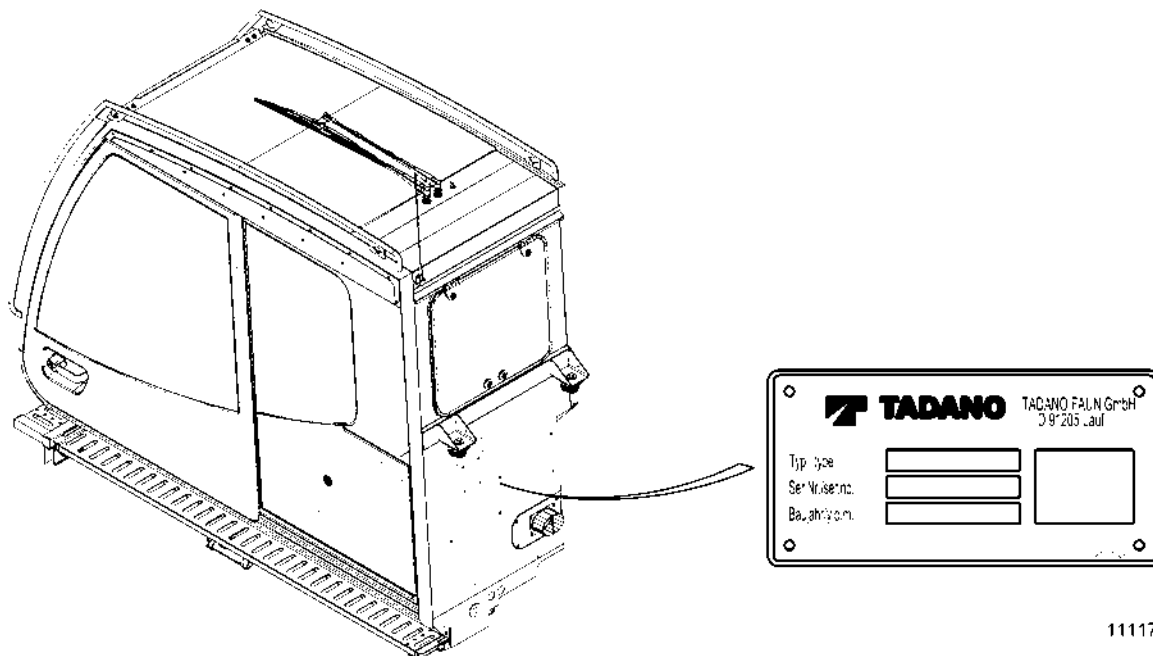

The model plate of the superstructure is on the left of the rear of the superstructure cab.

### 1.2 In case of Damage

In case of damage, contact the nearest TADANO workshop or TADANO dealer.

Specify the following:

- Chassis number or serial number
- Type and scope of damage.

### 1.3 Warranty

The type and manner of use of the mobile crane must be completely in accordance with the specifications in the operating manual.



### **NOTICE**

#### **Loss of guarantee**

If parts installed in the company are removed, changed or replaced with non-original parts, the crane authorization as well as the manufacturer's guarantee expires.

1. Do not dismantle original parts!
2. Do not modify original parts!
3. Use only TADANO original spare parts.

The mobile crane may be modified only after a written approval of the manufacturer.

In case of non-adherence, the warranty of the mobile crane becomes invalid. We do not assume liability for damage resulting from non-adherence to the operating manual and its notes or due to improper use of the mobile crane. The operating manual does not specify our sales and delivery conditions.

## 1.4 Structure of the Operating Manual

The cover page contains an image of the mobile crane. It specifies:

- the vehicle type,
- the chassis number or the serial number,
- the manufacturer,
- the After-sales Service.

"PREFACE" contains general information about the mobile crane and the operating manual.

"SAFETY NOTES" contain all the information required for the safe operation of the mobile crane.

"OPERATION" contains all Information required for the correct operation of the mobile crane.

"MAINTENANCE AND REPAIR" contains a list and description of all the inspection and maintenance activities. The TADANO After-sales Service Department provides additional information.

"CRANE TESTING INSTRUCTIONS" contains information about the checks to be carried out on the mobile crane.

"TROUBLESHOOTING" helps in locating and eliminating errors quickly.

"TECHNICAL SPECIFICATIONS" contains all the important technical data.

"Annex" contains documents of supplier companies as regards vehicle components as well as special equipment.



## 1.5 Using the Operating Manual

This operating manual should make it possible for the user to operate the mobile crane safely and use its functions. It provides important information that is a prerequisite for safe operation. Carrier (chassis) and superstructure have been separately explained.

The operating manual is primarily intended for the operator and the maintenance expert. The operator and the maintenance personnel must be able to access it at all times. The operating manual should thus be kept near the workplace of the operator, i.e. in the driver's or crane cab. The operating manual is a part of the mobile crane.

If you receive additional information from our after-sales service, make a note of it and keep it with the operating manual.

Read the operating manual carefully before the commissioning of the mobile crane. Be well acquainted with the content as well as the instruction signs and their meanings. You must also be acquainted with the structure, function and the actuation direction of all operating elements before operating the mobile crane.

	 <b>DANGER</b>
	<p><b>Risk of accident due to incorrect use.</b></p> <p>Incorrect use or maintenance of the mobile crane can lead to accidents. This could cause fatal injuries to persons.</p> <ol style="list-style-type: none"> <li>1. Operation and maintenance of the mobile crane may be carried out only by qualified and trained experts.</li> </ol>

Always adhere to the notes in the operating manual during all activities!

The operating manual describes the delivered design as well as the special equipment, if any. The Table of Contents helps you find the desired information. In addition, the header on every page also contains the title of the relevant chapter.

The control and switching equipment installed in the driver's cab (at the driver's seat) or the crane cab has been specified on several pages of the operating manual. The chapter "Crane components" at the beginning of the operating manual provides an overview of the carrier and the superstructure.

The images in the operating manual may deviate from the actual design. The functional information is not affected by this.

Please follow the specifications in the additional pamphlets of the vehicle documentation.

This operating manual has been translated to the best of the knowledge and capacity of the translator. Only the German version is definitive for the functional correctness.

The TADANO After-sales Service is at your disposal for answering any questions that you may have. Please contact the Customer Service Department if you have any questions even after reading through the operating manual. Put get all questions clarified before operating the mobile crane. The operating manual is not a work instruction for carrying out greater commissioning work. The TADANO After-sales Service will explain this to you.

If the mobile crane is sold, the operating manual must be handed over the new owner.

### 1.5.1 Symbol and warning labels

The following warning labels have been used in this operating manual.

	<p><b>⚠ DANGER</b></p> <p><b>Type and source of danger</b>                  If the warning is ignored, it could result in <b>immediate</b> death, serious body injuries (e.g. permanent handicap, inability to work for at least one week).</p>
	<p><b>⚠ WARNING</b></p> <p><b>Type and source of danger</b>                  If the warning is ignored, it could result in <b>possible</b> death, serious body injuries (e.g. permanent handicap, inability to work for at least one week).</p>
	<p><b>⚠ CAUTION</b></p> <p><b>Type and source of danger</b>                  If the warning is ignored, it could <b>possibly</b> or <b>probably</b> result in slight body injuries (e.g. temporary handicap, inability to work for max. one week) or material damage.</p>
	<p><b>NOTICE</b></p> <p><b>Type and source of danger</b>                  If this note is ignored, it could <b>possibly</b> or <b>probably</b> lead to considerable material damage to the mobile crane.</p>
<p><b>i</b></p>	<p>Provides information if adherence to specific instructions is important for economical use of the mobile crane or in case of additional information and tips about the use of the mobile crane.</p>

### 1.5.2 Definition of the direction specifications

Forward drive means: Moving in the direction of the driver's cab.

Reverse drive means: Moving in the direction of the tail-lights of the carrier.

Forward, backward, right, left as regards the mobile crane means that the driver's cab and the boom head point in the same direction. Front is then always the direction of the driver's cab.

Forward, backward, right, left in the driver's cab refers to the carrier. The driver's cab is then always forward.

Forward, backward, right, left in the crane cab refers to the superstructure. Forward is then always the direction of the boom head.

#### Option

Options, special equipment and country-specific versions are marked with \*).





## 2 General safety instructions

### 2.1 Basic Safety Information

#### 2.1.1 Use of the Mobile Crane

This mobile crane has been built in accordance with the latest technology and approved safety regulations. Nevertheless, danger to life and limb and damage to property may occur during its use. It is therefore necessary to pay attention to the operating instructions to reduce these risks.

It is only permitted to operate the mobile crane when it is technically in sound condition and in accordance with its regulations. Problems or faults which affect the safety of the mobile crane must be rectified immediately. Please contact TADANO After-sales Service if you have any questions.

	 <b>DANGER</b>
	<p><b>Improper use of the mobile crane!</b> Improper use causes danger to life and limb.</p> <ol style="list-style-type: none"> <li>1. Read and understand the operating instructions.</li> <li>2. Only trained, qualified personnel may operate the mobile crane.</li> </ol>

All specifications and descriptions in the operating instructions assume that the mobile crane is being operated and used as described in the chapter "Proper use".

#### Proper Use

Proper use of the mobile crane consists exclusively of the lifting and lowering of unfixed loads. To do this, the weight and center of gravity of the load must be known. The weight of the load may not exceed the lifting capacity of the mobile crane.

A bottom block or hook tackle, in either case approved by TADANO, must be reeved to the hoisting rope. The bottom block must be centered over the center of gravity of the load before lifting. It may only be operated in the permissible setup conditions.

The mobile crane may only be moved if this is permitted according to the available moving and lifting capacity charts. The setup conditions and specifications given in the operating instructions must be adhered to.

The mobile crane may only be operated in the temperature range from -25 °C to +40 °C (-13 °F to 104 °F) ambient temperature.

Any other use is classified as improper.

The manufacturer bears no liability for damage resulting from improper use of the mobile crane.

The responsibility for this is exclusively that of the director of operations and the crane operator.

#### Improper Use

Incorrect use includes:



- using equipment parts not approved for the mobile crane,



- using lifting capacity charts which do not correspond to the actual setup condition,
- working in slewing ranges and jib lengths which are not permitted according to the lifting capacity charts,
- working with setup conditions which are not permitted according to the lifting capacity charts,
- by-passing safety devices e.g. anti-twoblock device,
- increasing the jib length of the lifted load after an automatic safe load indicator shut-off,
- sliding, pushing or lifting loads with the outrigger beams, the outrigger cylinders or the suspension,
- sliding, pushing or lifting loads with the luffing or the slewing gear,
- using the mobile crane to break off fixed objects,
- using the mobile crane for handling operations,
- loading or unloading the mobile crane suddenly (use with chutes, containers or claws),
- using the mobile crane for work in which the swinging load alters in weight, e.g. filling a concrete container, containers or chutes,
- using the mobile crane to transport flammable or other hazardous materials,
- using the mobile crane to catch falling objects or parts,
- using the mobile crane for bungee jumping,
- driving the mobile crane in an unsuitable condition,
- driving on public roads when the equipment is not in a permitted state (dimensions, axle loads),
- using the mobile crane for pile-driving or vibrating operations.

The mobile crane may not be used for:

- rigging loads whose centers of gravity and weights are unknown and which are then released, e.g. by disconnecting, separating,
- working without the necessary additional equipment, e.g. two hook block operation,
- transporting loads on the carrier,
- carrying persons outside the driver's cab on the chassis,
- carrying persons in the crane cab while driving,
- carrying persons on the load or the load lifting device,
- carrying persons in workman's baskets without written authorization from the responsible authorities. National regulations of the area of use must also be observed.

### 2.1.2 Personnel Requirements

	 <b>DANGER</b>
	<p><b>Risk of accident due to incorrect use!</b> Incorrect use or maintenance of the mobile crane can lead to accidents. This could cause fatal injuries to persons.</p> <ol style="list-style-type: none"><li>1. Operation and maintenance of the mobile crane may be carried out only by qualified and trained experts.</li><li>2. Observe the warning and instruction signs.</li><li>3. Observe the operating instructions.</li></ol>

	<p><b>! DANGER</b></p> <p><b>Risk of accident due to inappropriate clothing!</b>          Loose clothing can get caught in rotating parts. This can lead to body parts being squeezed or crushed. Loose clothing can get caught on to protruding parts.</p> <ol style="list-style-type: none"> <li>1. Wear appropriate clothes; tie long hair and protect them with a hair net.</li> </ol>
	<p><b>! DANGER</b></p> <p><b>Danger due to influence of alcohol, drugs and medicines!</b>          The personnel should not be under the influence of alcohol, drugs or medicines or suffer from exhaustion. This is because in such situations, dangers cannot be correctly estimated.</p>
	<p><b>! WARNING</b></p> <p><b>Risk of slipping and accidents!</b>          When climbing and stepping on ladders, take utmost care especially in case of humid weather.</p> <ol style="list-style-type: none"> <li>1. Keep ladders clean at all times!</li> <li>2. Remove dirt and other greasy substances immediately and thoroughly.</li> <li>3. Always hold the ladder beams or handles while climbing up or down.</li> <li>4. Wear non-slip shoes and keep them clean.</li> <li>5. Ensure that the ladders are safe.</li> </ol>

General and type-specific driver and after-sales service training courses are carried out at TADA-NO Ltd..

Persons who are still undergoing training may only work on the mobile crane under the supervision of qualified members of staff.

### Crane Operators

The crane operator requires technical knowledge of mobile cranes and their applications.

The crane operator must be able to recognize risks to themselves and others and to implement suitable measures to avoid these risks.

Only trained and authorized personnel may work with the mobile crane.

The crane operator must fulfill the following prerequisites, among others:

- permission to drive and operate the mobile crane in the country of use,
- basic knowledge of working with mobile cranes and the qualifications required in the country of use,

## 2 General safety instructions

---

- the intellectual and physical requirements to be able to operate a mobile crane,
- knowledge and understanding of the operating instructions for the mobile crane,
- knowledge and understanding of the relevant accident prevention regulations.
- knowledge and understanding of the mobile crane emergency.

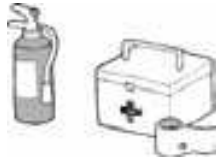

Only those persons who have been briefed and are aware of the valid accident prevention regulations may engage in the rigging of loads and signaling to the crane operator.

### Cleaning and Maintenance Personnel

The cleaning staff must possess relevant knowledge, e.g. onto which vehicle parts no high-pressure water cleaning jet may be directed.

Only trained personnel with specialist knowledge of and experience in the fields of electrics, electronics, hydraulics and pneumatics may carry out maintenance work on the mobile crane.



### Skilled Repair Technicians

Only qualified and trained, expert personnel may carry out repairs on the mobile crane. These are, for example, trained specialists from the fields of mechatronics or the automotive trade.

Only personnel from a specialist brakes workshop or with equivalent qualifications may carry out work on the brakes and compressed air system.

National regulations which differ from the above regulations should be observed.

### Personal Protective Equipment

	 <b>DANGER</b>
	<p><b>Falling of non-secured personnel!</b></p> <p>Installation personnel working on unsecured installation and maintenance work can fall and be seriously or fatally injured.</p> <ol style="list-style-type: none"><li>1. Use suitable aids to sure that personnel cannot fall from the mobile crane during installation and maintenance work (e.g. auxiliary crane, lifting platform, scaffolding or ladders).</li><li>2. Use the provided railing and ladders.</li><li>3. Wear personal protective gear.</li></ol>

Personal protective equipment must be worn for all work with and on the mobile crane. National regulations regarding this should also be observed.





If it is not possible to carry out installation or maintenance work from the ground or with the help of appropriate aids, the personnel must be secured against falling with personal protective equipment (e.g. safety belts).

Observe the accident prevention regulations of the country of use.

### 2.1.3 Planning Use

The national legislation and regulations applicable at the place of use must be observed.

	 <b>WARNING</b>
	<p><b>Missing information on use!</b></p> <p>A lack of information may make the planned work at the site of use unfeasible and may force the crane operator to improvise.</p> <ol style="list-style-type: none"> <li>1. Work with the crane may only be carried out when all documents/specifications are complete and correct.</li> </ol>

Smooth operation requires careful planning of use.

The operator must have all the required specifications and documents before going to the installation location.

#### When going to the installation location:

- an exact route plan,
- a plan to the place of use for the vehicle with regard to its length, width and height as well as its total weight, taking into accounting bridge loads, access heights and the width of streets,
- if necessary request police escort and obtain approval from the authorities,
- the necessary driving and special approvals,
- observe the paragraphs of the Road Traffic Licensing Regulations and the Highway Code (observe the regulations valid in the area of use),
- permissible axle loads and total weight for the journey.

#### When carrying out the planned work:



- a precise schedule,
- the type of planned crane use,
- weight and size of the load to be lifted,
- required jib length and lifting height,
- load bearing capacity of the ground at the site of the mobile crane (channels, water and gas pipes, underground channels or cavities);
- space and possible limitations at the site of the mobile crane,
- overhead electric lines and their voltage,
- more personnel for instructing or for loading/equipping work,
- communication procedure, contact addresses, emergency addresses,
- any authorization from the authorities.

Because of the existing specifications, the necessary crane equipment must be assembled to carry out the planned use:

- hook tackle or bottom blocks,
- jibs,
- counterweights,
- rigging ropes, chain suspension, cross beams and similar aids,
- support base plates,
- additional transport vehicle.

### Choice of Site

A basic prerequisite for working safely with a mobile crane is that it is used on ground which can bear sufficient load.

	 <b>WARNING</b>
	<p><b>Weak ground!</b> Weak ground implies risk of tipping and thus risk of accidents.</p> <ol style="list-style-type: none"><li>1. Only position and operate the mobile crane on ground which can bear sufficient load.</li><li>2. Thus, place outrigger plates underneath.</li></ol>



When selecting the site, it should be ensured that

- the available ground conditions can withstand the resulting strain,
- the outriggers can be extended in accordance with the value specified in the lifting capacity chart,
- the work can be carried out with as small a jib length as possible,
- there are no obstacles in the slewing range of the superstructure.

### Permissible Ground Pressure

When the mobile crane is supported, the support cylinders transmit the forces to the ground. The maximum force can reach almost the weight of the mobile crane including the load. These forces are sent directly into the ground via the surfaces of the outrigger pads. If these surfaces are insufficient, the ground must be appropriately supported.

The maximum supporting forces which can occur with 360° slewing of the load are specified in the supporting force tables.

	 <b>WARNING</b>
	<p><b>Tipping of the mobile crane due to unstable support!</b>                  In case of an unstable ground, there is a risk of tipping and thus a risk of accidents.</p> <ol style="list-style-type: none"> <li>1. Only use stable materials to support the crane, such as adequate wooden planks.</li> <li>2. The support must be situated centrally underneath the support plates so that the distribution of pressure is equal.</li> </ol>

The minimum support surface required may be calculated from the supporting force of the mobile crane (see supporting force table) divided by the permissible load bearing capability of the ground.

necessary support surface =	supporting force
	permissible load bearing capability of ground



On no account may the supporting surface be smaller than the required surface calculated.  
 If the load bearing capability of the ground is unknown, its strength must be determined with appropriate tests, for example with a penetrometer.

**Permissible ground pressure (extract from DIN 1054)**

Type of ground	daN/cm <sup>2</sup>
<b>Backfilled ground, not artificially compressed:</b>	0-1
<b>Natural, obviously untouched ground:</b>	
Mud, peat, moor earth	0
Fine to medium sand	1.5
Coarse sand to gravel	2.0
<b>Cohesive soils:</b>	
mushy	0
soft	0.4
firm	1.0
semi-solid	2.0
hard	4.0
<b>Rock with minimal jointing in good, unweathered condition and favourable stratification:</b>	
in closed sequence of strata	15
in bulky and columnar formation	30
<b>Artificially compressed ground:</b>	
Asphalt	5 - 15
Concrete B I	50 - 250
Concrete B II	350 - 550

**Slopes and depressions**

When choosing the site to position the mobile crane, it must be ensured that the mobile crane does not stand too close to ditches, slopes or trenches.

	 <b>WARNING</b>
	<p><b>Vehicle tips over!</b></p> <p>The edge of the slope or trench could cave in under the resulting stress and cause the mobile crane to turn over.</p> <ol style="list-style-type: none"> <li>1. A safe distance must be maintained between the mobile crane and the edge of the trench.</li> <li>2. Support slope or trench.</li> </ol>

A safe distance between the outriggers and the edge of the trench must be maintained, according to the type of ground.

The safe distance is measured from the edge of the trench.

Subsurface	Safe distance
Firm, natural, non-grainy soil ( $\alpha \geq 45^\circ$ )	1 times depth of depression ( $A = 1 \times T$ )
Grainy, soft or backfilled soil ( $\alpha \leq 30^\circ$ )	2 times depth of depression ( $A = 2 \times T$ )

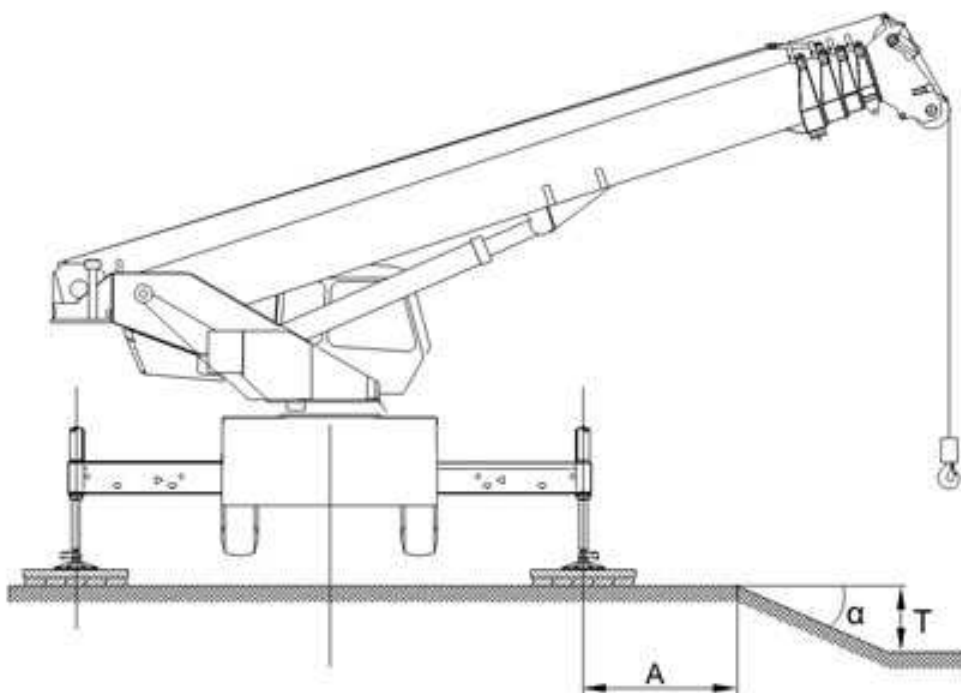



96031

T -	depth of depression	A -	safe distance	α -	gradient
-----	---------------------	-----	---------------	-----	----------



## 2.1.4 Outrigger



	 <b>WARNING</b>
	<p><b>Risk of accidents when extending the outriggers!</b></p> <p>If the operator cannot see the outrigger area, people who are present in this area may get injured.</p> <ol style="list-style-type: none"> <li>1. Evacuate people from the outrigger area of outriggers.</li> <li>2. Press the outriggers (extending and retracting) only when the operator or another person can see the outrigger area for the duration of the outrigger process.</li> </ol>

All 4 outrigger beams must be extended on the outrigger base in accordance with the selected lifting capacity chart.



All 4 outrigger cylinders must hold. Raise the tires completely off the ground.

Outrigger bases other than those specified in the lifting capacity charts are not permissible, because the transmission of forces to the outriggers is only guaranteed at points which are defined in its construction and appropriately designed.

The mobile crane must be leveled after extending the outrigger beams and the outrigger cylinder.



	 <b>DANGER</b>
	<p><b>Tipping of the mobile crane!</b></p> <p>The wrong outrigger bases can cause the mobile crane to tip over. Only the outrigger bases specified in the lifting capacity charts must be supported.</p> <ol style="list-style-type: none"> <li>1. Secure the outrigger beams mechanically in position with lock pins so that they cannot slip.</li> <li>2. Plug the lock pins completely and secure them.</li> </ol>

Not only the outrigger beams on the side of the load must be extended in accordance with the lifting capacity charts, but also the beams on the non-loaded side. The risk of accident is increased if the outrigger beams on the non-loaded side are not extended.

	 <b>DANGER</b>
	<p><b>Danger of the mobile crane tipping over if all outrigger beams and outrigger cylinders are not extended!</b></p> <p>If then a sudden reduction in load occurs, e.g. if the rope breaks or the load falls down, the boom shoots back and can cause the mobile crane to tip over backwards.</p> <p>It may also in fact be necessary to swing the load over the other side, where the outrigger beams are not extended, and the mobile crane would then fall over. The outrigger beams must be extended symmetrically.</p> <ol style="list-style-type: none"><li>1. Extend all 4 outrigger beams and outrigger cylinders as specified in the lifting capacity charts.</li><li>2. Plug the lock pins completely and secure them.</li></ol>

### Aligning the Mobile Crane

It is of great importance for safe operation that, as well as the correct and stable support of all support plates, the mobile crane is also evenly aligned.

	 <b>DANGER</b>
	<p><b>Tilted position causes danger that the mobile crane will tip over!</b></p> <p>If the boom is turned towards the slope on a mobile crane which is not evenly aligned, there is an increase in the jib length which can cause the mobile crane to tip over.</p> <ol style="list-style-type: none"><li>1. Align the mobile crane horizontally.</li></ol>

Example:

Boom length: 60 m (196.9 ft)



Inclination:  $5^\circ$

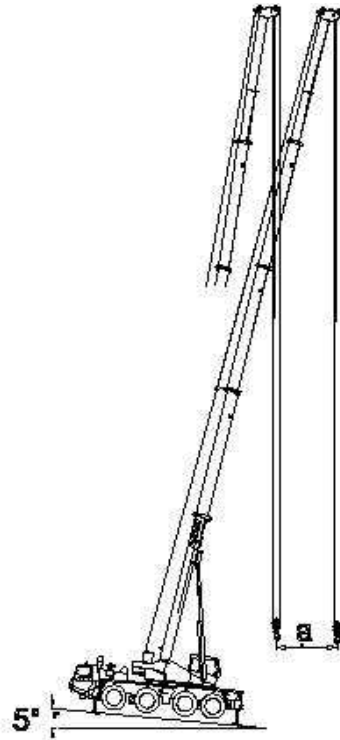



Jib length (a) increases by approx. 5 m (16.4 ft).

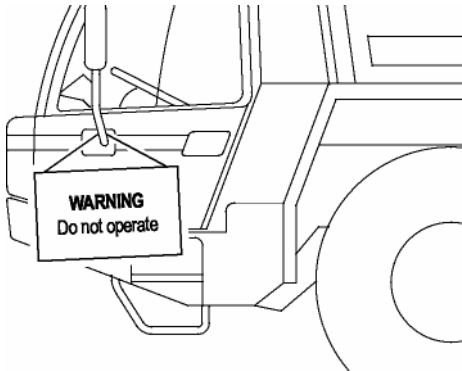

00000

### 2.1.5 Servicing and Maintenance

	<b>⚠ WARNING</b>
	<p><b>Risk of accident due to impermissible commissioning!</b></p> <p>If the vehicle is operated during maintenance and inspection, there are risks of accidents and damage to the vehicle.</p> <ol style="list-style-type: none"><li>1. Do not operate the mobile crane during maintenance and inspection work.</li><li>2. Secure the danger zone and do not allow unauthorized persons.</li><li>3. Indicate the maintenance work on the mobile crane using appropriate warning tags, e.g. on doors, on the steering wheel, on the control lever.</li></ol> <div style="display: flex; flex-direction: column; align-items: center;"></div>

	 <b>CAUTION</b>
	<p><b>Environmental damage due to inappropriate disposal!</b> Lubrication, operating and other auxiliary materials are subject to hazardous waste treatment.</p> <ul style="list-style-type: none"> <li>▶ These materials should not enter the ground, water, sewage system or ground water.</li> </ul> <ol style="list-style-type: none"> <li>1. Do not let oils and greases flow in an uncontrolled manner; always collect in suitable containers.</li> <li>2. Dispose of oils and greases properly. Follow the national regulations.</li> </ol>
	 <b>WARNING</b>
	<p><b>Danger of accidents from incorrect maintenance!</b> A significant proportion of cases of damage on/with mobile cranes is caused by the lack of and/or incorrect maintenance of the mobile crane.</p> <ol style="list-style-type: none"> <li>1. Maintenance work may only be carried out by trained personnel in accordance with the maintenance plan.</li> </ol>

Maintenance personnel must be able to recognize risks to themselves and others and to implement suitable measures to avoid these risks. Also refer to part C "Maintenance and repair".

Causes of damage from maintenance errors:

- lack of oil, grease, coolant or de-icing fluid in the various units,
- use of impermissible lubricants,
- water in the compressed air system,
- filter in the air dryer not changed on time,
- damage to the plastic tubing of compressed air and central lubrication system from drilling or welding, e.g. plastic tubing not covered or removed,
- sudden loss of pressure in the tires due to tire damage which has not been rectified,
- tightening torques of the nuts or screws not observed, e.g. when changing wheel or other installation work,
- units not functional e.g. brakes or steering, because of inadequate maintenance,
- faults on the brake and compressed air system, e.g. worn hoses,
- insufficient visual inspections carried out on steel construction, welded parts and parts subject to heavy loads,
- faults on the hydraulic system, e.g. worn hoses,
- worn ropes which need to be replaced and could break suddenly,
- faulty or insufficiently functional safety devices, e.g. automatic safe load indicator or anti-two-block device/limit switch of the hoisting winch.

### 2.1.6 Welding and alignment work



#### **WARNING**

##### **Improperly carried out welding or alignment work!**

If welding, heat treatments or alignment work is carried out improperly, loss of material properties must be expected.

Consult a crane expert if damage (e.g. cracks, distortions) are detected on the mobile crane.

Consult the crane manufacturer after investigating the fault.

The repair method should then be decided on in consultation between the crane manufacturer and the expert.

### Measures to protect electronic parts during welding



#### **NOTICE**

##### **High current during welding!**



The flow of current can cause damage to loose connections during welding, e.g. tooth flanks, bearings, spline ends, shafts, the electronics, the automatic safe load indicator, etc.

1. When electrowelding, the ground terminal of the welding machine must be connected directly to the part to be welded.
2. Welding regulations must be observed.



If it is necessary to carry out welding on the mobile crane, the following steps must be carried out before beginning work to protect the electronic control units:

- Switch off battery main switch (on the superstructure as well, if present),
- Remove the battery cable at the negative pole, then remove the battery cable at the positive pole and connect them with each other (on the superstructure as well, if present).
- Pull out plugs of electronic parts.

## 2.1.7 Risk of fire and explosion

	 <b>DANGER</b>
	<p><b>Risk of fire and explosion!</b></p> <p>Not observing the following points can lead to burns or potentially fatal injuries.</p> <ul style="list-style-type: none"> <li>▶ The mobile crane must <b>not</b> be used in areas with a risk of explosion.</li> <li>▶ It is prohibited to smoke and use open flames when working with fuel or during maintenance on the batteries.</li> <li>▶ Fire or open flames are forbidden on the mobile crane.</li> <li>▶ The mobile crane must be refueled only when the engine is switched off and in outdoor or well ventilated areas.</li> </ul> <ol style="list-style-type: none"> <li>1. Follow the accident prevention regulations.</li> <li>2. Wipe off spilled fuel or oil immediately using suitable tools (e.g. oil binders).</li> <li>3. Replace insulation or sound insulation mats which have become contaminated with fuel, oil or grease with new, clean insulation mats. Contaminated insulation mats near hot surfaces present a serious fire risk.</li> <li>4. Do <b>not</b> use flammable solvents.</li> <li>5. Keep flammable objects such as dry leaves or paper waste away from the engine.</li> <li>6. Only carry out maintenance on units which have cooled down, otherwise there is a danger of burns.</li> <li>7. During grinding and welding, ensure that dangerous objects and materials are located at a safe distance.</li> </ol>

## 2.1.8 Different lengths of the hydraulic cylinders

	 <b>WARNING</b>
	<p><b>Extending/retracting of hydraulic cylinders due to temperature differences!</b></p> <p>Temperature variations alter the oil volume of the hydraulic oil. This can lead to variations in the length of the hydraulic cylinders.</p> <p>The mobile crane can therefore become unstable.</p> <p>This may result in accidents. This could cause serious or fatal injuries to persons.</p> <ol style="list-style-type: none"> <li>1. Check the condition of the hydraulic cylinders if temperatures fluctuate or after long periods of operation.</li> </ol>

The hydraulic oil heats up while the crane is being used.

Temperature variations alter the oil volume in the hydraulic cylinders, e.g. derrick cylinders or outrigger cylinders. This can lead to differences in length of the cylinders and has a particular impact after long periods of operation. The difference in length can be determined using the diagram below.

Example:

a telescope cylinder with 6.5 m (21.3 ft) stroke alters its length by approx. 24 cm (9.5 in) with a 50 °C (122 °F) difference in the hydraulic oil temperature.

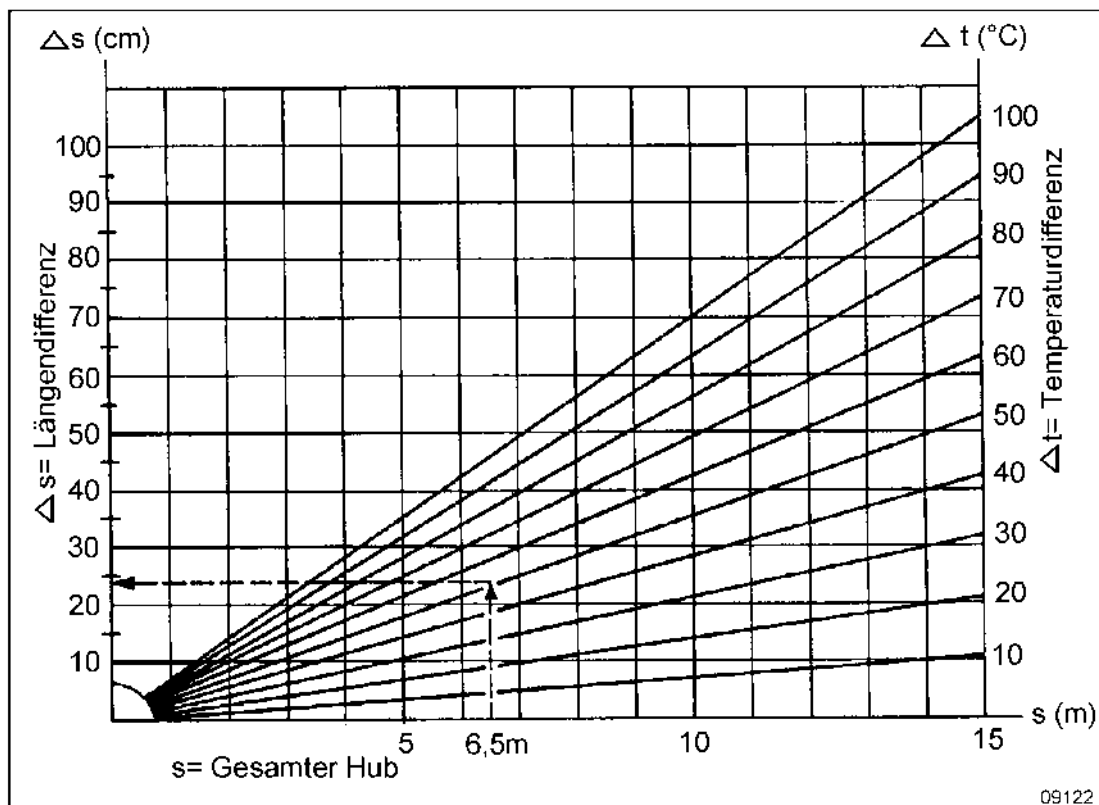

09122

### 2.1.9 Dismounting and disposal

Dispose of operating materials, lubricants and auxiliary materials in an environment-friendly manner.

The components of the mobile crane should be separated as per their reuse value and subjected to recycling.

- Scrap the remaining metallic components.
- Give plastic parts for recycling.
- Sort the remaining components as per their material composition and dispose them appropriately.

Follow the legal regulations applicable in the country of application for proper and environment-friendly disposal.



## 2.2 Basic Safety Information for the Superstructure

### 2.2.1 Warning and Instruction Signs

All warning and instruction signs put up on the mobile crane describe important safety precautions. Note that the warning and instruction signs must always be clean and completely legible. Inform the TADANO After-sales Service or dealer about damaged or missing signs.

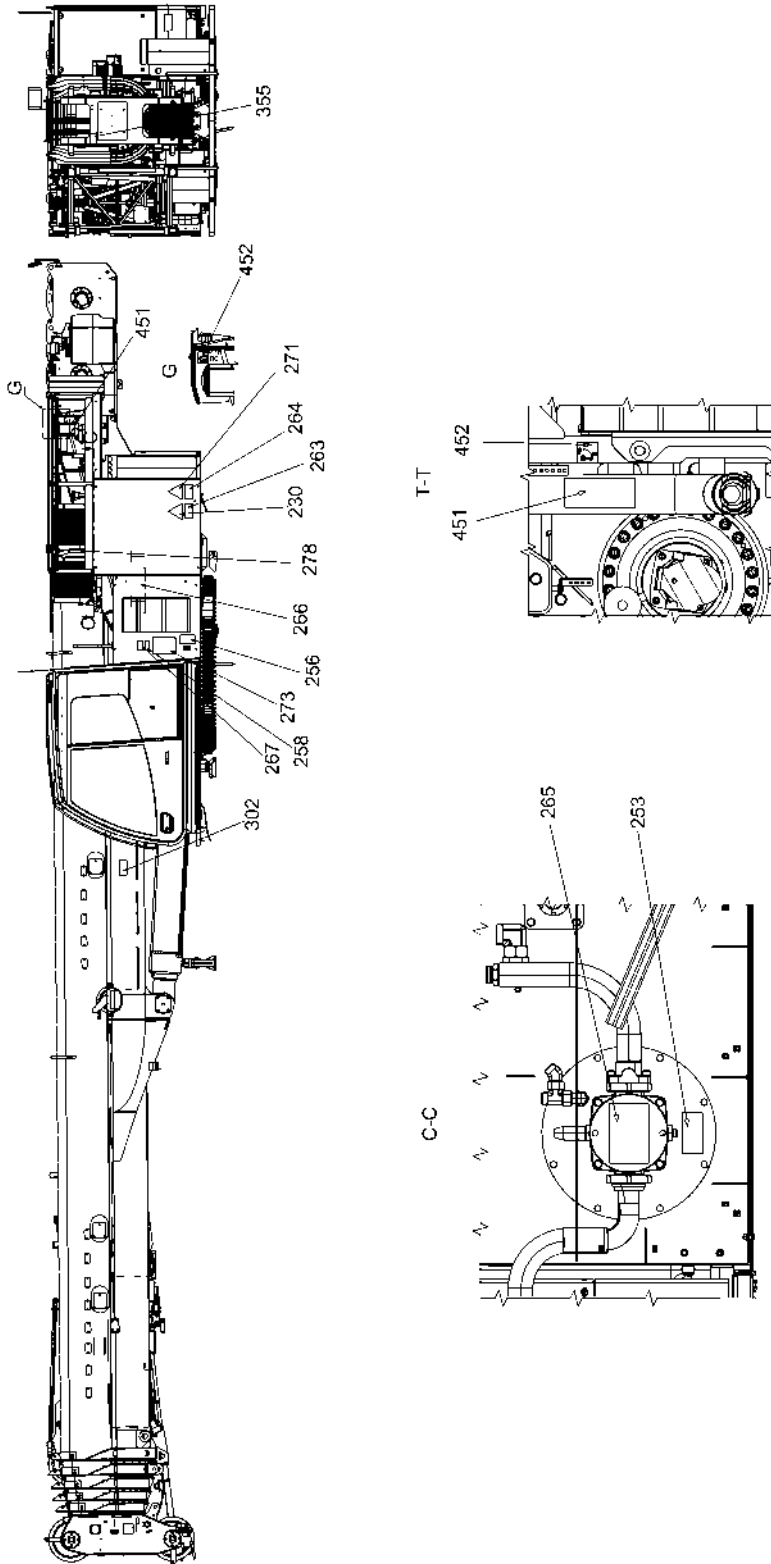

99707029325\_D1  
A-0910

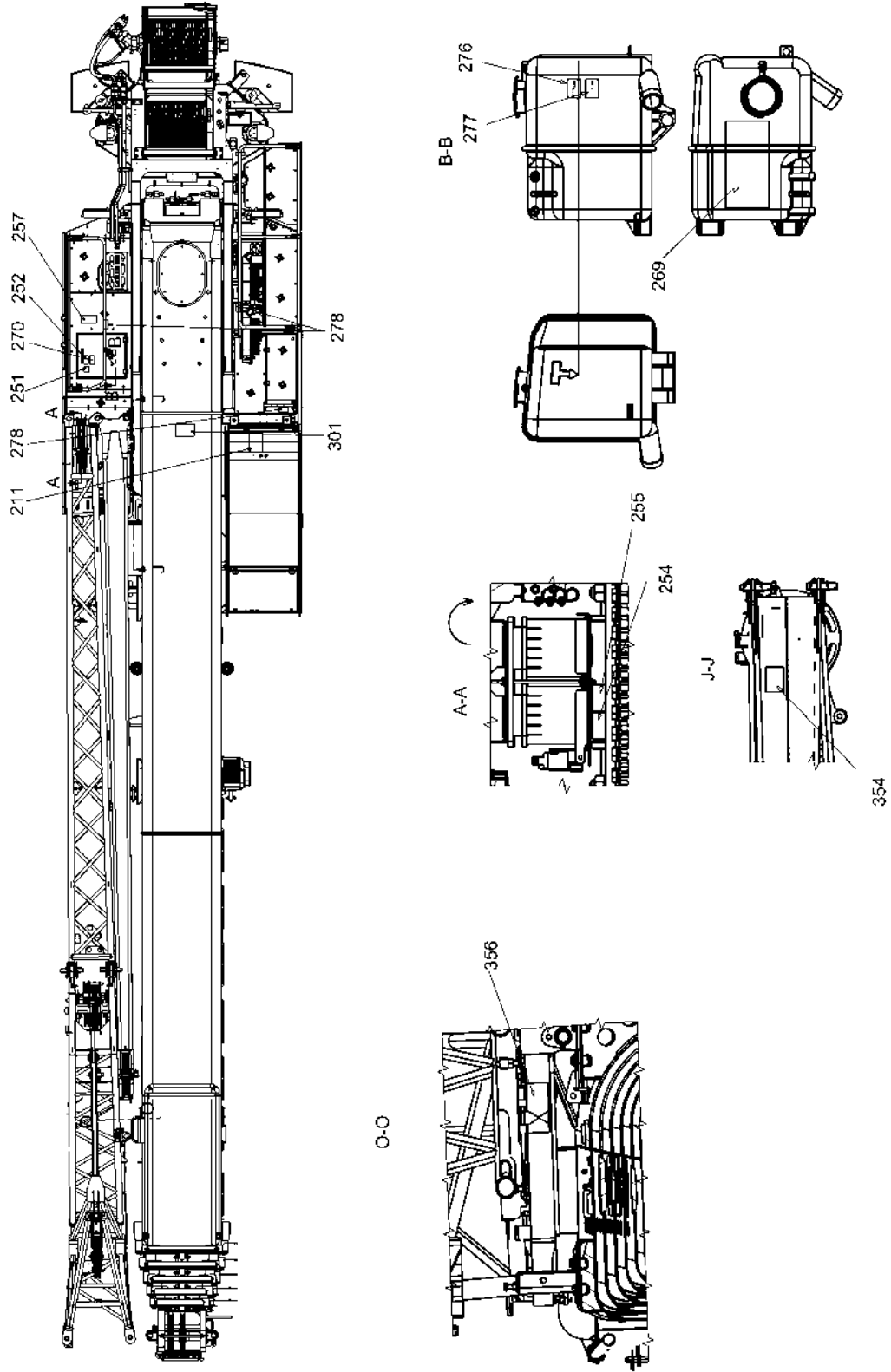



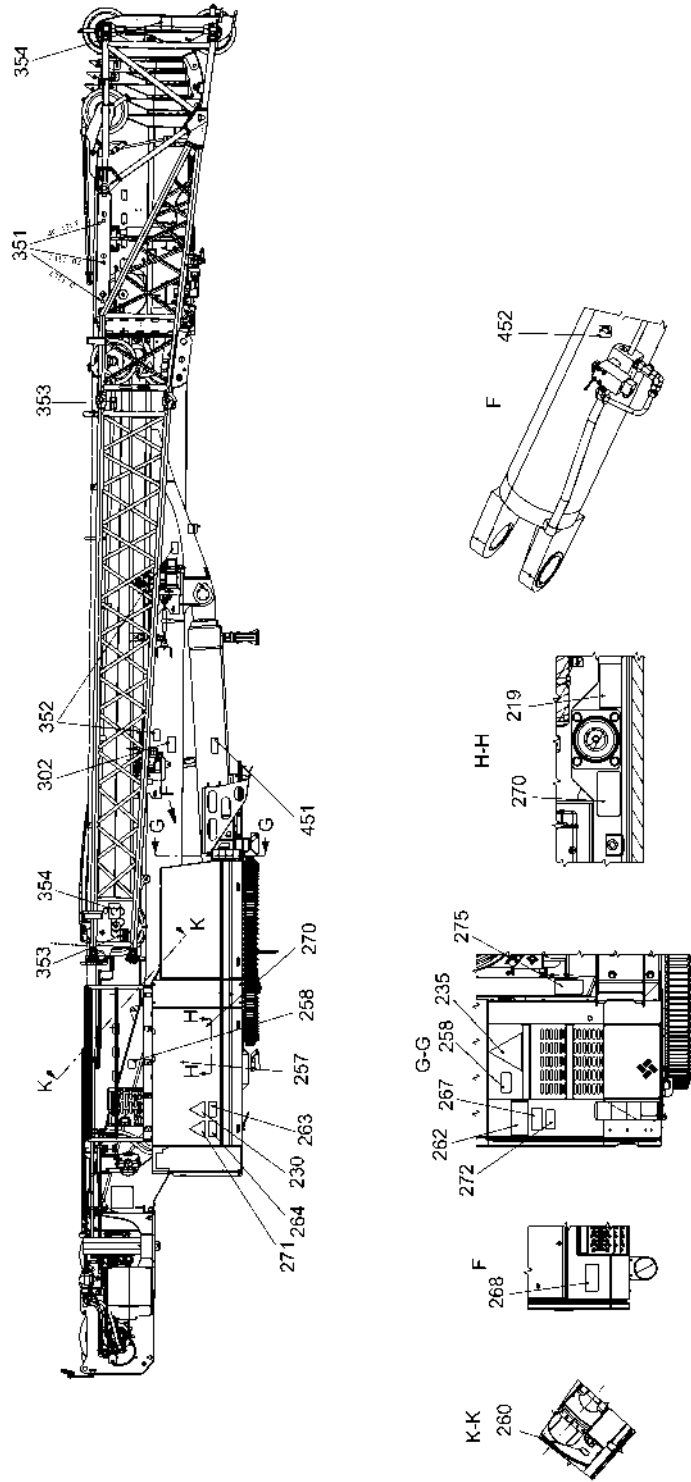



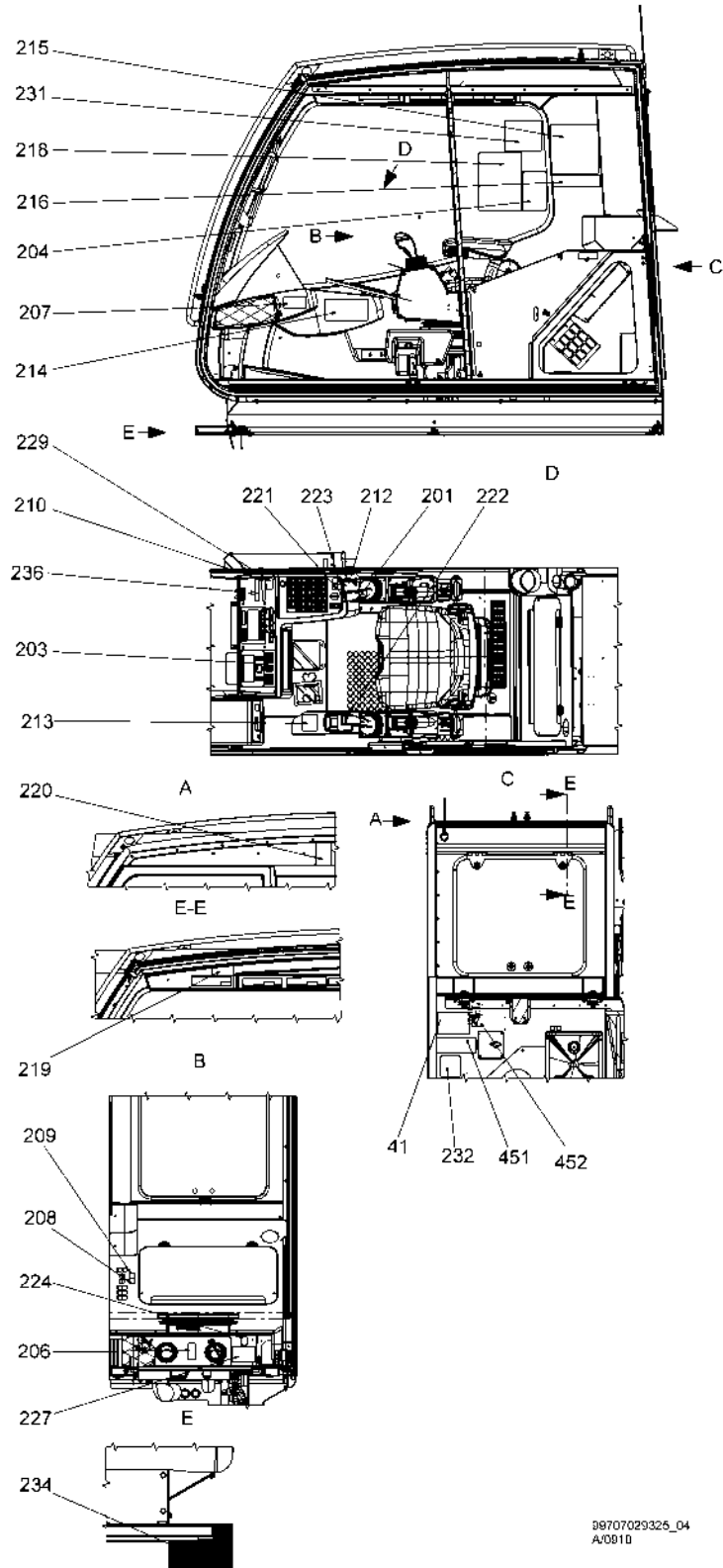

99707029325\_02  
A0910

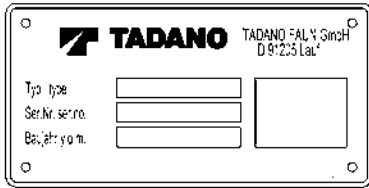
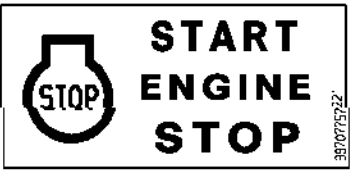
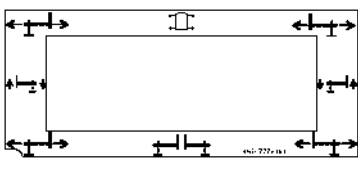





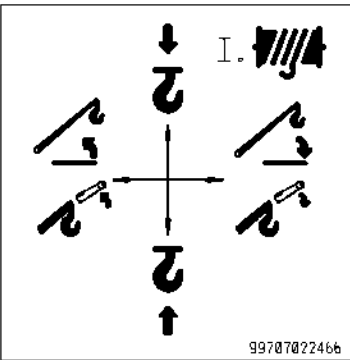
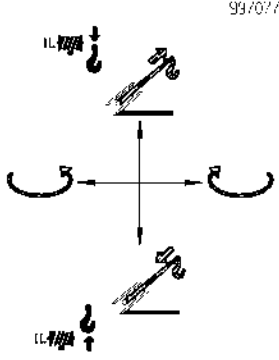



























































99.01.029025\_03  
R008 0



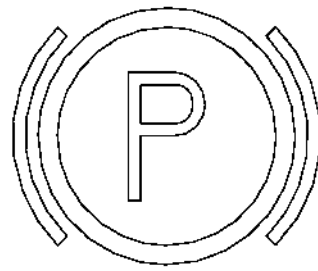
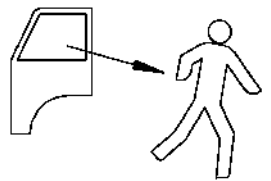
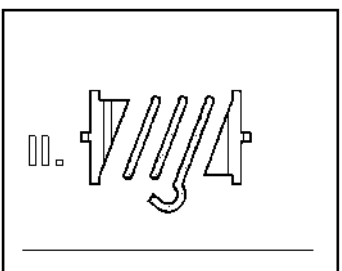

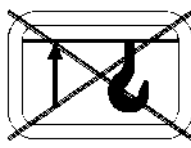
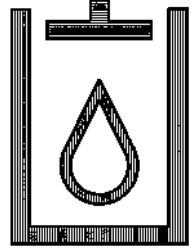
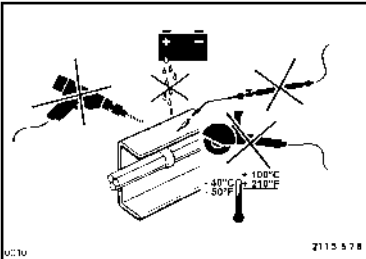
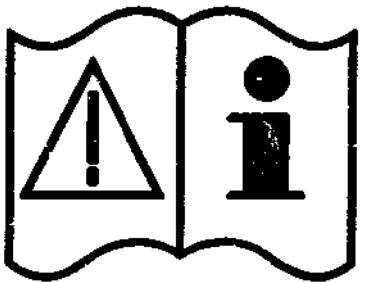

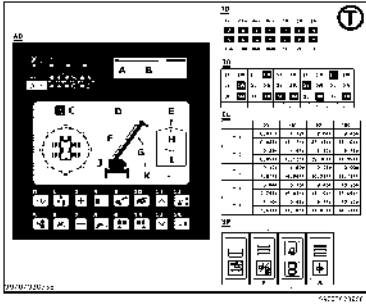
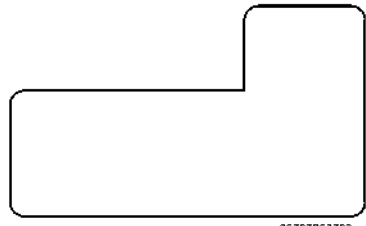



99707029325\_04  
A/0810

<p>41</p> 	<p>201</p> 	<p>203</p> 
<p>204</p>  <p><b>DANGER !</b></p> <p>ELECTROCUTION HAZARD CAN CAUSE SEVERE INJURY OR DEATH KEEP MINIMUM SEPARATION DISTANCE FROM POWER LINES PER LOCAL / STATE / FEDERAL REGULATIONS</p>  <p><b>PELIGRO !</b></p> <p>MANTENGA DISTANCIA PRUDENCIAL DELANTE DE LOS CABLES DE ALTA TENSION</p> <p>7745634</p>	<p>206</p> <p>FREE</p>  <p>SWING</p>  <p>LOCKED</p> <p>7757266</p>	<p>207</p> <p>SWING BRAKE</p>  <p>7757262</p> <p>208</p> <p>12V DC</p> <p>7757241</p>
<p>209</p> <p>24V DC</p> <p>7757240</p>	<p>210</p> <p><b>DANGER</b></p> <p>NEVER EXTEND BLIND SIDE OUTRIGGERS WITHOUT A SPOTTER</p> <p>7757230</p>	<p>211</p> 
<p>212</p>  <p>99787822466</p>	<p>213</p>  <p>99707772601</p>	<p>214</p> <p><b>WARNING</b></p> 
<p>215</p>	<p>216</p> <p><b>DANGER</b></p> <p>IMPROPER OPERATION CAN RESULT IN SEVERE INJURY OR DEATH. DO NOT LIFT PERSONNEL. REFER TO ANSI B30.56-1985, PARA 3.1.2 FOR INSTRUCTIONS.</p> <p>7757276</p>	<p>218</p>

<p><b>⚠ DANGER</b></p> <p><b>ELECTROCUTION HAZARD</b></p> <p>CAN CAUSE SERIOUS INJURY OR DEATH. NEVER OPERATE THIS CRANE WITHIN MINIMUM DISTANCE OF A POWER SOURCE OR POWER LINE SPECIFIED BY LOCAL REGULATIONS. ALWAYS NOTIFY POWER OR UTILITY COMPANY.</p> <p>THIS MACHINE IS NOT EQUIPPED WITH ANY WARNING OR PROTECTIVE DEVICES. ALWAYS KEEP YOUR REFLECTION, ELECTRICAL LINE, AND LOAD AWAY.</p> <p>NEVER OPERATE CRANE ANY PART THEREOF OR LOAD WITHIN 20 FEET OF ANY ELECTRICAL POWER LINE OR POWER SOURCE OR SUCH DISTANCE AS IS SPECIFIED OR REQUIRED BY LOCAL OR OTHER APPLICABLE SAFETY CODES OR REGULATIONS.</p> <p>NEVER OPERATE, SERVICE OR MAINTAIN THIS CRANE WITHOUT PROPER INSTRUCTIONS. IT IS THE OPERATOR'S RESPONSIBILITY TO PROVIDE ALL SAFETY DEVICES OR MEANS THAT ARE NECESSARY OR REQUIRED FOR ANY USE, OPERATION, SET-UP OR SERVICE.</p> <p><b>⚠ DANGER</b></p> <p>THIS MACHINE IS NOT EQUIPPED WITH ANY WARNING OR PROTECTIVE DEVICES. EXTREME CAUTION MUST BE EXERCISED BY ALL PERSONNEL WORKING WITH AND AROUND THIS CRANE WHEN IN THE PROXIMITY OF ENERGIZED POWER SOURCE OR POWER LINES. DEATH OR SERIOUS INJURY CAN RESULT FROM CONTACT OR INDISTINCT CLEARANCE.</p> <p>ALL PERSONNEL MUST BE ADEQUATELY TRAINED IN SAFETY PROCEDURES.</p> <p>7757340</p>	<p>219</p>  <p><b>⚠ WARNING</b></p> <p>DO NOT TOUCH THE FAN</p> <p>7748462</p>	<p>7757310 <b>HAND SIGNALS</b></p> <table border="1"> <tr> <td> HOIST</td> <td> LOWER</td> <td> USE WITH HOIST</td> <td> USE INLINE (ON LIFTING)</td> </tr> <tr> <td> RAISE BOOM</td> <td> LOWER BOOM</td> <td> MOVE SLOWLY</td> <td> RAISE THE BOOM AND LOWER THE LOAD</td> </tr> <tr> <td> LOWER THE BOOM AND RAISE THE LOAD</td> <td> SWING</td> <td> STOP</td> <td> EMERGENCY STOP</td> </tr> <tr> <td> TRAVEL</td> <td> DO EVERYTHING</td> <td> TRAVEL (WITH HOIST)</td> <td> TRAVEL (WITH HOIST)</td> </tr> <tr> <td> EXTEND BOOM</td> <td> RETRACT BOOM</td> <td> EXTEND BOOM (ON HOIST)</td> <td> RETRACT BOOM (ON HOIST)</td> </tr> </table>	 HOIST	 LOWER	 USE WITH HOIST	 USE INLINE (ON LIFTING)	 RAISE BOOM	 LOWER BOOM	 MOVE SLOWLY	 RAISE THE BOOM AND LOWER THE LOAD	 LOWER THE BOOM AND RAISE THE LOAD	 SWING	 STOP	 EMERGENCY STOP	 TRAVEL	 DO EVERYTHING	 TRAVEL (WITH HOIST)	 TRAVEL (WITH HOIST)	 EXTEND BOOM	 RETRACT BOOM	 EXTEND BOOM (ON HOIST)	 RETRACT BOOM (ON HOIST)
 HOIST	 LOWER	 USE WITH HOIST	 USE INLINE (ON LIFTING)																			
 RAISE BOOM	 LOWER BOOM	 MOVE SLOWLY	 RAISE THE BOOM AND LOWER THE LOAD																			
 LOWER THE BOOM AND RAISE THE LOAD	 SWING	 STOP	 EMERGENCY STOP																			
 TRAVEL	 DO EVERYTHING	 TRAVEL (WITH HOIST)	 TRAVEL (WITH HOIST)																			
 EXTEND BOOM	 RETRACT BOOM	 EXTEND BOOM (ON HOIST)	 RETRACT BOOM (ON HOIST)																			
<p>220</p>   <p>983393</p>	<p>221</p>  <p>9970777846</p>	<p>222</p>  <p>223</p> 																				
<p>224</p> 	<p>227</p>  <p>2113 578</p>	<p>229</p>  <p>2213-152</p>																				
<p>230</p>  <p>99707745214</p>	<p>231</p>  <p>99707732012</p> <p>99707732012</p> <p>09-02</p>	<p>232</p>  <p>99707028763 010609</p>																				

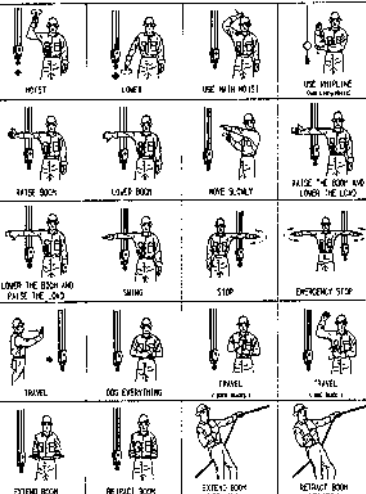

<p>235</p>  <p>99701991275</p>	<p>236</p>  <table border="1" data-bbox="646 246 1380 481"> <tr> <td>385/95R25 170F</td> <td>9bar/ 128 PSI</td> </tr> <tr> <td>385/95R25 170E</td> <td>10bar /142 PSI</td> </tr> <tr> <td>445/95R25</td> <td>9bar /128 PSI</td> </tr> <tr> <td>525/80R25</td> <td>7bar /100 PSI</td> </tr> </table> <p>99707041649</p>		385/95R25 170F	9bar/ 128 PSI	385/95R25 170E	10bar /142 PSI	445/95R25	9bar /128 PSI	525/80R25	7bar /100 PSI
385/95R25 170F	9bar/ 128 PSI									
385/95R25 170E	10bar /142 PSI									
445/95R25	9bar /128 PSI									
525/80R25	7bar /100 PSI									
<p>251</p> <p><b>NOTICE</b></p> <p>COOLING FLUID SEE OPERATORS MANUAL FOR INSTRUCTIONS</p> <p>7741396</p>	<p>252</p> <p><b>NOTICE</b></p> <p>HYDRAULIC FLUID SEE OPERATORS MANUAL FOR INSTRUCTIONS</p> <p>7741397</p>	<p>253</p> <p>EXTERNAL BATTERY STARTING PLUG SOCKET 24V / DC</p> <p>7741391</p>								
<p>255</p> <p>BATTERY CHARGING PLUG SOCKET 24V / DC</p> <p>7741392</p>	<p>256</p> <p><b>⚠ DANGER !</b></p> <p>ELECTROCUTION HAZARD CAN CAUSE SEVERE INJURY OR DEATH</p> <p>KEEP MINIMUM SEPARATION DISTANCE FROM POWER LINES PER LOCAL / STATE / FEDERAL REGULATIONS</p> <p><b>⚠ PELIGRO !</b></p> <p>MANTENGA DISTANCIA PRUDENCIAL DELANTE DE LOS CABLES DE ALTA TENSION</p> <p>7745634</p>									
<p>258</p> <p><b>⚠ WARNING</b></p>  <p><b>DO NOT STEP HERE</b></p> <p>7757214</p>	<p>257</p> <p><b>⚠ CAUTION</b></p> <p>HAZARDOUS CONDITION CAN CAUSE BURN INJURY</p> <p>DO NOT TOUCH HOT EXHAUST PIPE KEEP CLEAR WHEN ENGINE IS RUNNING</p> <p>7767269</p> <p>260</p> <p><b>⚠ CAUTION</b></p> <p>DO NOT USE OXYGEN !</p> <p>DO NOT OPERATE UNIT WITHOUT PROPER NITROGEN GAS PRESSURE RELEASE ALL HYDRAULIC AND GAS PRESSURE BEFORE DISASSEMBLING UNIT SEE SERVICE INSTRUCTIONS FOR ADDITIONAL INFORMATION</p> <p>997025275</p>									
<p>262</p>  <p><b>⚠ DANGER</b></p> <p>KEEP CLEAR OF LOWERING OR RAISING BOOM TO AVOID SERIOUS INJURY.</p> <p>7767235</p>	<p>263</p>  <p><b>⚠ DANGER</b></p> <p>FALLING LOAD OR BOOM CAN CAUSE SEVERE PERSONAL INJURY OR DEATH STAY CLEAR OF LOAD, BOOM AND BOOM</p> <p>7767242</p>	<p>264</p>  <p><b>⚠ DANGER</b></p> <p>SWINGING STRUCTURE STAY CLEAR TO PREVENT SEVERE PERSONAL INJURY OR DEATH</p> <p>7767241</p>								

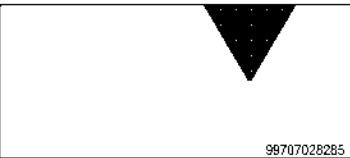
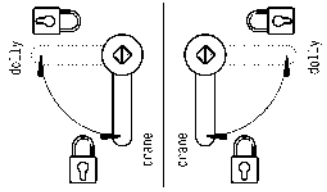

<p>265</p> <p><b>NOTICE</b></p> <p><b>HYDRAULIC FLUID ONLY</b></p> <p>READ OPERATORS MANUAL BEFORE SERVICING ALL CYLINDERS MUST BE RETRACTED WHEN CHECKING FLUID LEVEL.</p> <p>302/7757342</p>	<p>266</p> <p><b>DIESEL FUEL</b></p> <p>7757345</p>	<p>267</p>  <p><b>WARNING</b></p> <p>HAZARD CAN CAUSE INJURY DO NOT MOUNT OR CLIMB ON BOOM JIB OR OUTRIGGER</p> <p>7757350</p>
<p>268</p>  <p><b>CAUTION</b></p> <p>DO NOT STUMBLE OVER PROJECTION</p> <p>7757351</p>	<p>269</p>  <p><b>WARNING</b></p> <p>DO NOT REMOVE RADIATOR CAP WHEN ENGINE IS HOT.</p> <p>7757352</p>	<p>270</p>  <p><b>WARNING</b></p> <p>AUTOMATIC FAN START KEEP HANDS AWAY STOP ENGINE TO SERVICE</p> <p>7757354</p>
<p>271</p> 	<p>272</p> <p><b>CAUTION</b></p> <p>LOW CLEARANCE BE AWARE OF OVER HEAD OBSTRUCTION</p> <p>7757358</p>	<p>275</p>  <p><b>WARNING</b></p> <p>KEEP CLEAR OF MOVING PARTS TO PREVENT SERIOUS BODILY INJURY.</p> <p>7757361</p>
<p>273</p> <p>7757310</p> <p><b>HAND SIGNALS</b></p> 	<p>276</p> <p>max.—</p> <p>278</p> <p><b>HANDHOLD</b></p> <p>7757226</p>	<p>277</p> <p>min.—</p> <p>301</p> 
<p>302</p>  <p><b>DANGER</b></p> <p>KEEP CLEAR OF LOWERING OR RAISING BOOM TO AVOID SERIOUS INJURY.</p> <p>7757335</p>	<p>351</p> <p>0° TILT   20° TILT   40° TILT</p> <p>9970/7759327   9970/7759327   9970/7759327</p>	<p>352</p> <p><b>WARNING</b></p> <p>HAZARDOUS CONDITION CAN CAUSE SEVERE INJURY USE A TAGLINE TO PREVENT RAPID SWINGING OF JIB FROM BOOM WHEN JIB IS RELEASED AT STOWING BRACKET</p> <p>7757338</p>

<p>353</p> <p><b>⚠ WARNING</b></p> <p>HAZARDOUS CONDITION CAN CAUSE SEVERE INJURY</p> <p>USE A TAGLINE TO PREVENT RAPID SWINGING OF JIB FROM BOOM WHEN JIB IS RELEASED AT STOWING BRACKET</p> <p><small>1/20/0394</small></p>	<p>354</p>  <p><small>7757334</small></p> <p><b>⚠ WARNING</b></p> <p>HAZARD CAN CAUSE INJURY</p> <p>KEEP CLEAR OF OUTRIGGER WHILE CRANE IS OPERATING</p>	<p>355</p> <p><b>⚠ WARNING</b></p> <p>HAZARDOUS CONDITION CAN CAUSE SEVERE INJURY</p> <p>DO NOT REMOVE JIB PIVOT PINS AT BOOM HEAD UNTIL JIB IS PINNED TO STOWING BRACKET</p> <p><small>1/20/0392</small></p>
<p>356</p>  <p><small>99707028285</small></p>	<p>451</p> <p><b>⚠ DANGER</b></p> <p>HAZARDOUS LEVEL POSITIONING CAN CAUSE SERIOUS ACCIDENTS! DO NOT OPERATE CRANE WITH BOOM RESTING.</p> <p>• ONLY TRAINED PERSONNEL SHOULD BE PERMITTED TO OPERATE CRANE. • ALWAYS SECURE BOOM PINS. • ALWAYS OPERATE CRANE WITH BOOM RESTING. • SEE OPERATING MANUAL FOR INSTRUCTIONS.</p> <p><small>22/07/2017</small></p>	<p>452</p>  <p><small>99707792837</small></p>

2.2.2 Before Operating the Crane

	<p><b>⚠ DANGER</b></p> <p><b>Risk of accident!</b></p> <p>Presence of unauthorized persons or vehicles in the working area of the mobile crane can lead to accidents (e.g. collisions) resulting in injuries or death.</p> <ol style="list-style-type: none"> <li>1. Unauthorized persons should not be present within the danger area of the mobile crane.</li> <li>2. Secure the danger zone in order to prevent unauthorized access to the installation location.</li> <li>3. Work with signal persons at installation locations with heavy traffic.</li> </ol>
	<p><b>⚠ WARNING</b></p> <p><b>Risk of accident!</b></p> <p>The mobile crane must be in a sound technical condition during its entire period of use. Improper components can fail and cause accidents.</p> <ol style="list-style-type: none"> <li>1. Continually check the condition of the mobile crane.</li> <li>2. Follow the following points.</li> </ol>

Before beginning work it should be ensured that the mobile crane is in good condition. Use the climbing aids and ladders intended for this purpose to carry out checks on areas out of reach from the ground.

Before starting work, ensure that

- all covers are present and closed,
- all safety devices are present, correctly installed and in good condition (automatic safe load indicator, anti-two-block device, dead man's switch\*, etc),
- all handles, steps, step surfaces, ladders and ascents are free of dirt, ice and snow,

- windows, mirrors, lamps and lights are clean and a good view in all directions is ensured,
- there are no persons or objects under or near the mobile crane,
- The seat is adjusted such that the pedals are correctly actuated and the steering wheel can be easily operated,
- there are no loose objects in the leg space of the crane cab that can slide under the accelerators during the travel,
- all control and operating elements in the crane cab are functional before starting the engine,
- all control elements and lights are properly displayed after the engine start,
- the function of the automatic safe load indicator has been checked,
- the operating conditions have been correctly and completely entered on the basis of the lifting capacity chart,
- there is no danger near live wires and other supply lines (oil, gas). Especial care is requested here.



For the duration of the crane operation, the following must be observed:



- hydraulic axle suspension is blocked during crane operation,
- there is nobody on the mobile crane except the crane driver,
- only lift load if there is nobody in the danger zone,
- moving and working with load is only permitted in accordance with the notes in the lifting capacity charts,
- the maximum permissible wind speed and load wind area are not exceeded,
- the ground is sufficiently strong enough for the duration of the crane work,
- if the light is poor, the working area is sufficiently well lit,
- the crane cab may not be vacated as long as the engine is running or a load is hanging on the hook.

No authorized persons may be on or near the mobile crane during setting up and crane work.



### 2.2.3 Safety equipment

#### Automatic safe load indicator



	 <b>DANGER</b>
	<p><b>Incorrect or incomplete entries of operating conditions in the automatic safe load indicator!</b></p> <p>Incorrect or incomplete entries of operating conditions in the automatic safe load indicator can lead to accidents. The mobile crane can reach an unstable area and tilt. This could be fatal.</p> <ol style="list-style-type: none"> <li>1. Enter the operating conditions have been correctly and completely on the basis of the lifting capacity chart,</li> <li>2. Check the operating conditions before the crane operation.</li> </ol>

	 <b>DANGER</b>
	<p><b>Overriding the automatic safe load indicator!</b></p> <p>If the automatic safe load indicator is bypassed, the load moment limiting mechanism no longer functions.</p> <p>The mobile crane can enter the overload zone and turn over. This could cause serious or fatal injuries to persons.</p> <ol style="list-style-type: none"><li>1. A bypass may only be used to demobilize the mobile crane if the unit is faulty.</li></ol>

### Anti-twoblock device

	 <b>DANGER</b>
	<p><b>Risk of accident due to overriding the anti-twoblock device!</b></p> <p>By-passing the anti-twoblock device can cause the bottom block to run against the boom head.</p> <p>Boom head, bottom block or hoisting rope could be damaged and the load could drop to the ground. This could cause serious or fatal injuries to persons.</p> <ol style="list-style-type: none"><li>1. A bypass may only be used if the unit is faulty.</li><li>2. The hoisting should be completed with a signaller, extremely carefully and very slowly.</li></ol>
	<p>The automatic safe load indicator has a setup mode for installing and dismantling the jib. In this setup mode, the anti-twoblock device has automatic bridging. The operation should be carried out in unloaded condition and with utmost care.</p>

### Limit switch of hoisting winch

	 <b>DANGER</b>
	<p><b>Running off of the hoisting rope from the winch drum.</b></p> <p>A faulty hoisting winch limit switch can cause the hoisting rope to come completely unwound from the winch drum and the hoist rope to break. This could cause serious or fatal injuries to persons.</p> <p>The hoisting winch limit switch prevents, with a shut-off, the last three turns of hoisting rope from unwinding from the hoisting winch drum.</p> <ol style="list-style-type: none"><li>1. This function should be checked regularly.</li><li>2. The rope must not become slack.</li></ol>

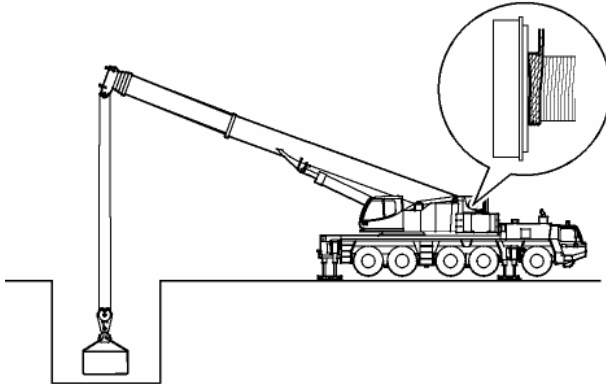

Function check:







1. Extend telescopes and unwind hoisting rope – with small load – until at least three turns of the rope remain on the winch drum.
- ⇒ The hoisting winch must now shut off.



### Crane Capacity Warning Light\*)

The "crane capacity" warning light located on the outside of the mobile crane indicates various loading states of the mobile crane.

	<p><b>! DANGER</b></p> <p><b>Overloading of the mobile crane!</b></p> <p>If the red light lights up, the mobile crane is overloaded.</p> <ol style="list-style-type: none"> <li>1. When the red light lights up the mobile crane should be brought out of the overload zone immediately.</li> <li>2. Vacate the work area of the mobile crane immediately.</li> </ol>
<p style="text-align: right;">08140</p>	<p>Loading states:</p> <p>Red (3): Overload zone: Bring the mobile crane back into the permissible range via a movement to reduce the load moment e.g. luffing up, or lowering the load.</p> <p>Yellow (2): Warning zone: carry out all crane movements with great care.</p> <p>Green (1): Permissible zone</p>

### 2.2.4 Crane operation with load

	<p> <b>DANGER</b></p> <p><b>Overloading of the mobile crane!</b> Lifting the loads on the ground by raising the boom can lead to boom overload or can also cause the crane to tilt. Raising movements are not switched off via the automatic safe load indicator.</p> <ul style="list-style-type: none"><li>▶ Loads may not be dragged.</li></ul> <ol style="list-style-type: none"><li>1. Carry out load movements only using the hoisting winch.</li><li>2. Lift the loads only vertically.</li></ol>
	<p> <b>DANGER</b></p> <p><b>Danger of accident – swinging loads!</b> Swinging loads can fall and cause fatal injuries to persons.</p> <ul style="list-style-type: none"><li>▶ It is forbidden to remain under swinging loads.</li></ul> <ol style="list-style-type: none"><li>1. Monitor the loads constantly and maintain eye contact with the signal persons.</li><li>2. Do not lift and move loads over persons.</li><li>3. Secure wide loads against turning or swinging due to the use of ropes for instance.</li><li>4. Set up work sequences such that there are no long lifting times of the load.</li></ol>
	<p> <b>DANGER</b></p> <p><b>Risk of accident due to bad view!</b> If the weather conditions (e.g. rain, snow, fog) deteriorate and the load and the signal persons cannot be seen, there is an increased risk of accident.</p> <ol style="list-style-type: none"><li>1. Abort the crane operation till the visibility conditions permit a danger-free operation.</li></ol>

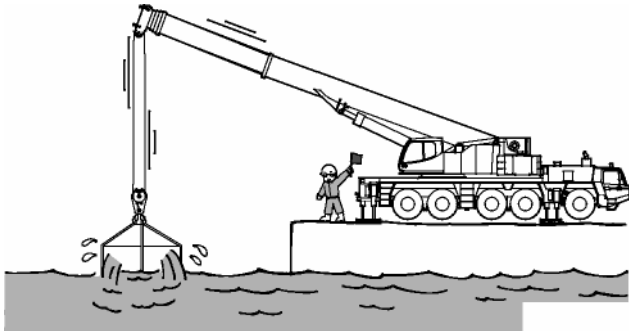
	<p><b>! WARNING</b></p> <p><b>Crane control lever improperly actuated.</b> Very fast lifting, derricking, turning and braking movements can lead to the load swinging.</p> <ol style="list-style-type: none"> <li>1. The larger the load or the greater the boom length, the more careful the movements should be.</li> <li>2. Execute the crane work with utmost care.</li> </ol>
	<p><b>! WARNING</b></p> <p><b>Load swinging!</b> A load can swing due to fast crane movements or changed wind conditions and lead to the mobile crane being overload or collide with the mobile crane.</p> <ol style="list-style-type: none"> <li>1. Carry out crane movements slowly and carefully.</li> <li>2. Remove the load slowly and carefully.</li> </ol>
	<p><b>! WARNING</b></p> <p><b>Overload due to lifting of loads in water!</b> The weight of a load in water can be several times greater due to the water that it soaks. If a load is lifted out of the water, its weight increases due to elimination of lift.</p> <ol style="list-style-type: none"> <li>1. Lift the load slowly and carefully and let the water drain.</li> </ol> 

The crane operator must ensure that the mobile crane is in a condition which is safe to operate before beginning each job with the crane.

All safety devices, such as brakes, anti-two-block device, hoisting winch limit switch, automatic safe load indicator, etc. must be in a functional condition.

The crane operator must observe the following points:

- the dimensions, the weight and the centre of gravity of the load to be lifted must be known,
- the loads in the lifting capacity chart must be adhered to and not exceeded,
- the mobile crane must be supported horizontally on a surface which is capable of bearing its load,

- the outrigger base is set in accordance with the lifting capacity chart and the counterweight used,
- the automatic safe load indicator is set correctly in accordance with the setup condition of the mobile crane,
- sling gear, load lifting device and suspension elements are suitable for the load to be lifted and have sufficient load-bearing capacity,
- sling gear, load lifting device and suspension elements are part of the load to be lifted and must be subtracted from the bearing capability specified in the lifting capacity chart.

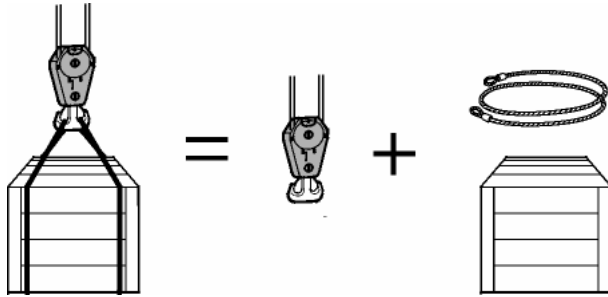

### Example of the Calculation of the Actual Loading Capacity of the Mobile Crane:

Permissible lifting capacity according to lifting capacity chart (gross load)	11.1 t (24,471.3 lbs)
Weight of rigging ropes	0.1 t (220.5 lbs)
Weight of cross beams	0.1 t (220.5 lbs)
Weight of bottom block	0.4 t (881.9 lbs)
<b>Actual loading capacity of the mobile crane (net load)</b>	<b>10.5 t (23,148.5 lbs)</b>

In this case, the weight of the load to be lifted may not be greater than the calculated loading of the mobile crane: 10.5 t (23,148.5 lbs).



### Counterweight

	<p><b>⚠ DANGER</b></p>
	<p><b>Incorrect counterweights may cause the mobile crane to tip over!</b> The mobile crane could turn over. This could cause fatal injuries to persons. Only the counterweights belonging to the mobile crane may be attached.</p> <p>1. Use counterweights in accordance with the specifications in the lifting capacity table to guarantee stability while working with the crane.</p>

The necessary counterweight is determined from the necessary jib length and the weight of the load to be lifted.



### Operation with two hook blocks

	 <b>WARNING</b>
	<p><b>Risk of accident due to lifting of two separate loads!</b>          Simultaneous lifting of two different loads can lead to damage to the mobile crane or overload.</p> <ul style="list-style-type: none"> <li>▶ Simultaneous lifting of two different loads is prohibited.</li> </ul> <ol style="list-style-type: none"> <li>1. Always lift only <b>one</b> load.</li> </ol>

During two-hook operation, the lifting or lowering of a load should be carried out with the lightest component. The load should always be lifted completely freely.

In the automatic safe load indicator, the actual length of the jib as well as the boom extension of the existing lines should also be entered in addition to the counterweight and the outrigger base.



The reeving on the telescope boom head should never be less than the reeving of the jib. It must always be either equal to or greater than the reeving on the jib. Non-adherence to this regulation can lead to a failure of the hoisting winch or the rope for the telescope boom head.

Every load should be freely lifted completely with the hook having the maximum horizontal distance from the rotating centre.

If the hook block on the telescope boom head is loaded in case of a lifted load, the load display of the automatic safe load indicator displays an incorrect value.

During work with the main and the auxiliary winch, the hoisting rope of the main winch must always be led over the boom head and the hoisting rope of the auxiliary winch over the jib (single top, heavy-lift fly jib, etc.). Else, there is a risk of overheating due to intertwining and chafing of the rope. The telescopic boom should never be lowered when load is attached to both of the hook blocks.

### Hoisting winch and reeving of the hoisting rope

	 <b>DANGER</b>
	<p><b>Hoisting rope breaks!</b>          If the crane operator disregards the maximum permissible traction force of the hoisting rope, it could break. This could cause fatal injuries to persons.</p> <ol style="list-style-type: none"> <li>1. Observe the maximum traction force of the hoisting rope.</li> <li>2. The following specifications must be observed.</li> </ol>

The lifting power of a mobile crane is dependent on the traction force of the hoisting winch and number of reeved part lines.

When working with the "direct" line (= 1 line), it is only possible to lift as much weight as the hoisting winch can pull (see notes on the lifting capacity charts).

If the load to be lifted is greater than the traction force of the hoisting winch, the hoisting rope must be reeved between the sheaves in the boom head and the coil in the hook block as often as it is necessary according to the pulley principle.

The specifications in the notes to the lifting capacity table and in the operating manual must be observed when reeving.

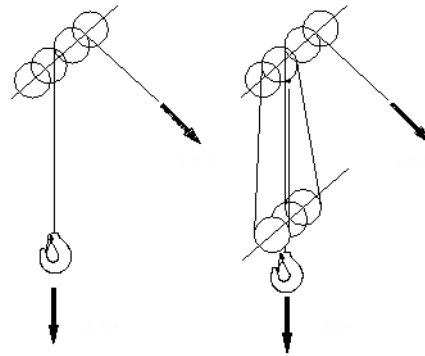



with one line – with four lines

99293

	<div style="background-color: #e67e22; color: white; padding: 5px;"><b>⚠ DANGER</b></div> <p><b>Damage to the hoisting winch caused by overloading!</b></p> <p>If the crane operator disregards the maximum permissible traction force of the hoisting winch, the hoisting winch can become damaged and drop the load. This could cause fatal injuries to persons.</p> <ol style="list-style-type: none"> <li>1. The maximum traction force must be observed.</li> </ol>
<p><b>i</b></p>	<p>In Germany, the proportion of the theoretical service life of the hoisting winch must be calculated in accordance with the accident prevention regulations "VBG D8, Winding, lifting and pulling equipment". If the end of the theoretical service life of the hoisting winch has been reached, a general overhaul of the hoisting winch must be arranged.</p> <p>For the execution of the general overhaul of the hoisting winch, see also chapter "Crane Testing Instructions".</p> <p>If, after ten years, the end of the theoretical service life of the crane has not yet been reached, the hoisting winch may continue to be operated without a general overhaul if the crane expert confirms that the calculation of the service life used is fit for purpose and correct. The crane expert should subject the winch to a detailed inspection and make a statement regarding the continued operation of the winch.</p> <p>National regulations of the area of use must also be observed.</p>

### Consideration of Wind Influences

	 <b>WARNING</b>
	<p><b>Tipping of the mobile crane!</b></p> <p>Working with a crane when the wind speed is high can cause the load to swing back and forth. In the worst case, the mobile crane could tip over or the boom could break off. This could cause fatal injuries to persons.</p> <ol style="list-style-type: none"><li>1. Only carry out crane work when the wind speed is at a permissible level.</li><li>2. The following points must be observed.</li></ol>

The following specifications must always be observed.

- The crane operator must find out about the expected wind speeds during the use of the crane before beginning work. Further enquiries should be made at the relevant meteorological office if the weather situation is unclear.
- The maximum permissible wind speeds, which are detailed in the notes to the lifting capacity chart or in the chart itself, may not be exceeded.
- If, during the use of the crane, the wind speed increases over the permissible value, crane work must stop immediately and the boom must be retracted and laid down.

### Reference values for the evaluation of the prevailing wind speeds

Wind strength		Wind speed		Evaluation of the wind
Beaufort force	Designation	m/s (ft/s)	km/h (mph)	
0	calm	0-0.2	1	Wind calm, smoke rises vertically.
1	light air	0.3-1.5	1-5	Wind direction only shown in column of smoke, not by wind vane.
2	light breeze	1.6-3.3	6-11	Wind can be felt on the face, leaves rustle, wind vane moves.
3	gentle breeze	3.4-5.4	12-19	Leaves and small twigs move. Pennant unfurls.
4	moderate breeze	5.5-7.9	20-28	Raises dust and loose paper, moves twigs and thin branches.
5	fresh breeze	8.0-10.7	29-38	Small trees begin to sway. Foam forms on lakes.
6	strong wind	10.8-13.8	39-49	Moves large branches, whistling in overhead wires, difficult to use umbrellas.
7	high wind	13.9-17.1	50-61	Whole trees move, effort needed to walk against the wind.
8	very high wind	17.2-20.7	62-74	Twigs break off from trees, walking in the open air is very difficult.
9	gale	20.8-24.4	75-88	Minor damage to buildings (chimney covers and roof tiles fall off).
10	severe gale	24.5-28.4	89-102	Uproots trees, significant damage to buildings.
11	hurricane-like gale	28.5-32.6	103-117	Widespread storm damage (very rare inland).
12	Hurricane	32.7-36.9	118-133	Most severe devastation.

### Influence and Consideration of Wind Effects

Crane operation is generally only permissible up to the wind speed which is specified in the notes to the lifting capacity chart or in the chart itself. If the load has a high wind surface the permissible wind speed for this must be calculated.

### Example of the calculation of the reduced wind speed:

$A_{Wvorh}$	wind surface present of the load to be lifted in $m^2$ ( $ft^2$ )
$A_{Wper}$	permissible load wind area in $m^2$ ( $ft^2$ ) (see diagram 2 "Load wind surface")
$F_w$	wind force present on the load to be lifted in N (lb)
$q$	Ram pressure in $N/m^2$ ( $lb/ft^2$ )
$v_{red}$	reduced wind speed in m/s ( $ft/s$ ) (see diagram 1 "Ram pressure")

### Estimates:

Permissible wind speed for the mobile crane	<b><math>v = 12 \text{ m/s (39.4 ft/s)}</math></b> (from notes to lifting capacity table)
Weight of load to be lifted:	<b><math>m = 20 \text{ t (44100 lbs)}</math></b>
Wind surface present of load to be lifted:	<b><math>A_{Wvorh} = 40 \text{ m}^2 (430.5 \text{ ft}^2)</math></b>

### Procedure:

1. From diagram 1 "Ram pressure", a ram pressure of  **$88 \text{ N/m}^2 (1.8 \text{ lb/ft}^2)$**  results for a wind speed of  $v = 12 \text{ m/s (39.6 ft/s)}$ .
2. From diagram 2, a permissible load wind area of  **$A_{Wzul} = 24 \text{ m}^2 (258.3 \text{ ft}^2)$**  results for the load to be lifted  $m = 20 \text{ t (44100 lbs)}$ .
3.  $F_W = q \times A_{Wper} \rightarrow 88 \text{ N/m}^2 (1.8 \text{ lb/ft}^2) \times 24 \text{ m}^2 (258.3 \text{ ft}^2) = \mathbf{2112 \text{ N (464.9 lb)}}$   
Therefore: A wind force of  $F_W = 2112 \text{ N (464.9 lb)}$  acts on a load of  $20 \text{ t (44100 lbs)}$  with the permissible load wind area  $A_{Wper} = 24 \text{ m}^2 (258.3 \text{ ft}^2)$ .

**Case 1:**  $A_{Wvorh} \leq A_{Wper}$

The load can be carried in accordance with the notes in the lifting capacity charts.

**Case 2:**  $A_{Wvorh} > A_{Wper}$

The reduced wind speed must be calculated.

4.  $A_{Wvorh} > A_{Wper} \rightarrow 40 \text{ m}^2 (430.4 \text{ ft}^2) > 24 \text{ m}^2 (258.3 \text{ ft}^2)$
5. To calculate maximum permissible ram pressure:

$q =$	$F_W$	$=$	$2112 \text{ N}$	$=$	<b><math>52.8 \text{ N/m}^2 (1.1 \text{ lb/ft}^2)</math></b>
	$A_{Wvorh}$		$40 \text{ m}^2$		

For the available load wind area  $A_{Wvorh} = 40 \text{ m}^2 (430.4 \text{ ft}^2)$ , a maximum permissible ram pressure of  $q = 52.8 \text{ N/m}^2 (1.1 \text{ lb/ft}^2)$  results for the calculated wind strength  $F_W$ .

1. Therefore from diagram 1 "Ram pressure", a maximum permissible wind speed of  **$v_{red} = \text{m/s}$**  ( $29.5 \text{ ft/s}$ ) results for the back pressure  $q = 52.8 \text{ N/m}^2 (1.1 \text{ lb/ft}^2)$ .

### Result:

For this specific load, the maximum permissible wind speed of  **$v_{red} = 9 \text{ m/s (29.5 ft/s)}$**  should not be exceeded.

Diagramm 1  
Staudruck





Diagramm 2  
Lastwindfläche

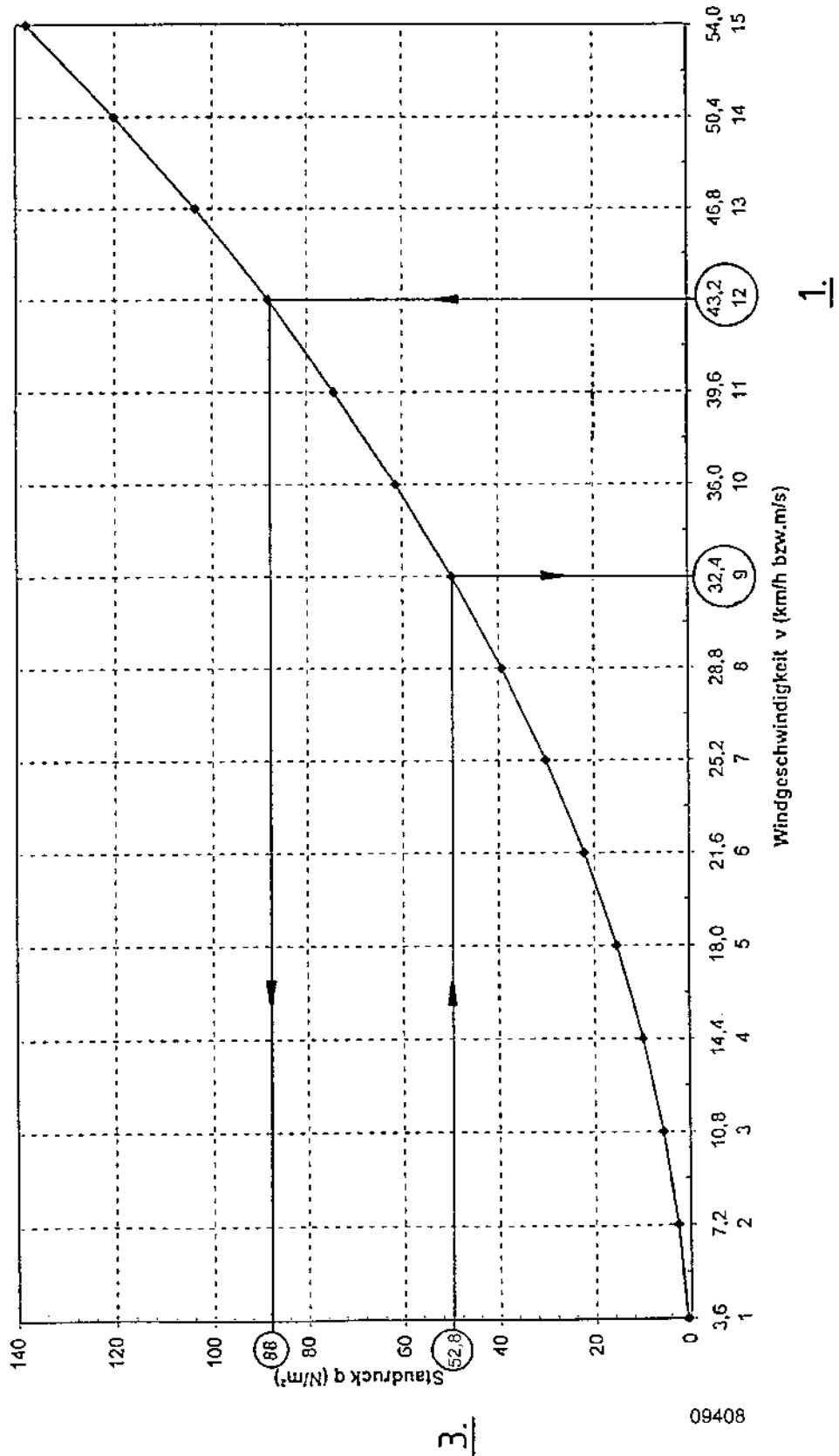
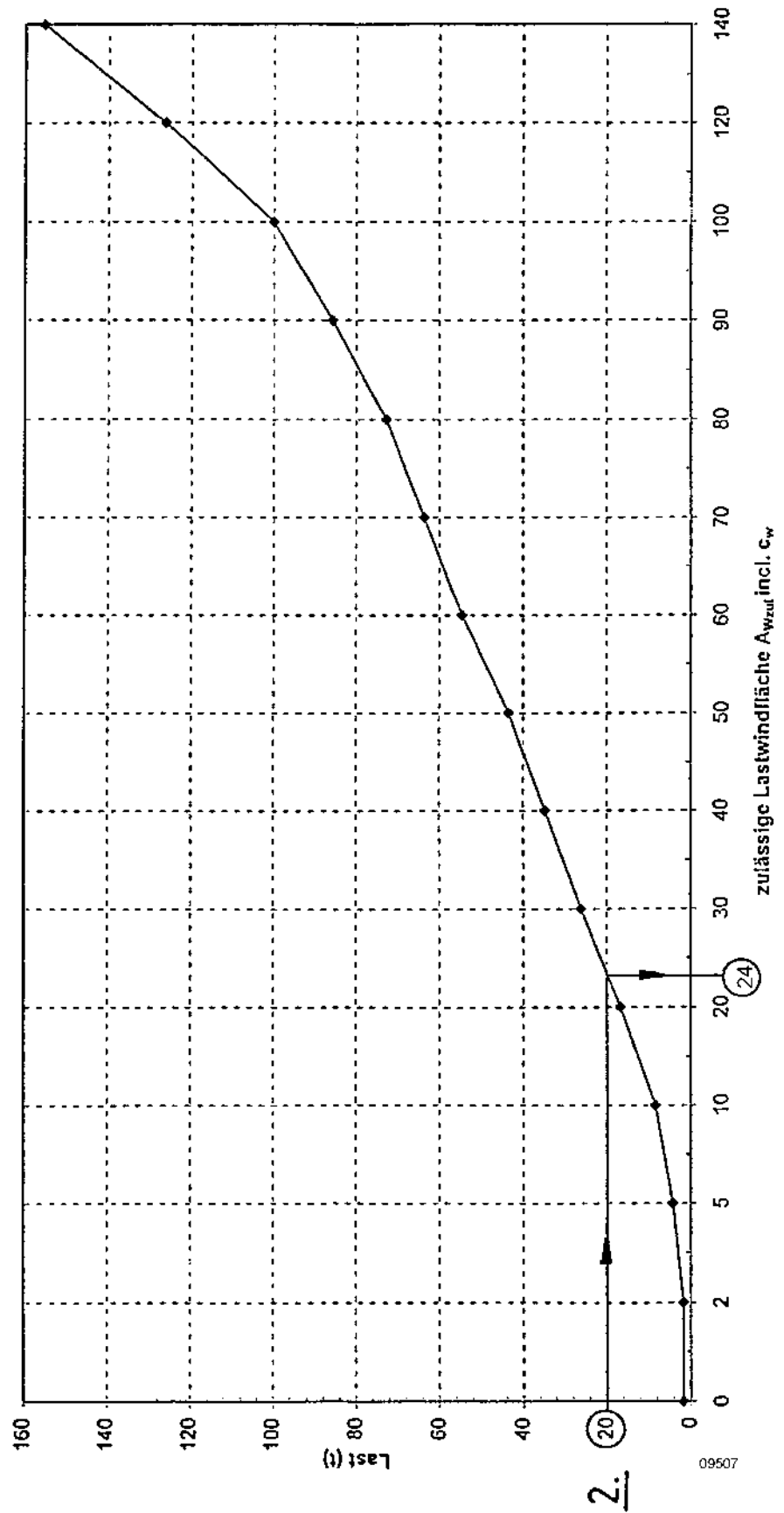

### Hand signals for instructions

The crane operator must always keep the load and/or the load lifting device in his field of vision during all crane movements. Attached loads may only be moved by the crane operator at the signal of the signaler or another person previously named as responsible for this.

	<b>⚠ CAUTION</b>
	<p><b>Unclear hand signals!</b></p> <p>Unclear hand signals can lead to accidents in which people could be fatally injured.</p> <ol style="list-style-type: none"> <li>1. Discuss hand signals on both sides, give them clearly and keep to them strictly.</li> </ol>

If the view of the crane operator is blocked by an obstacle, the mobile crane/load may only be moved with the help of a signaler for this purpose.

The instructions may be given by two-way radio or hand signals. It must be ensured that no misunderstandings arise between the signaler and the crane operator with regard to the instructions.

The person giving the hand signals must always have eye contact with the crane operator and be standing at a safe distance from the load and the load lifting device.

The following hand signals are recommended for the work movements:

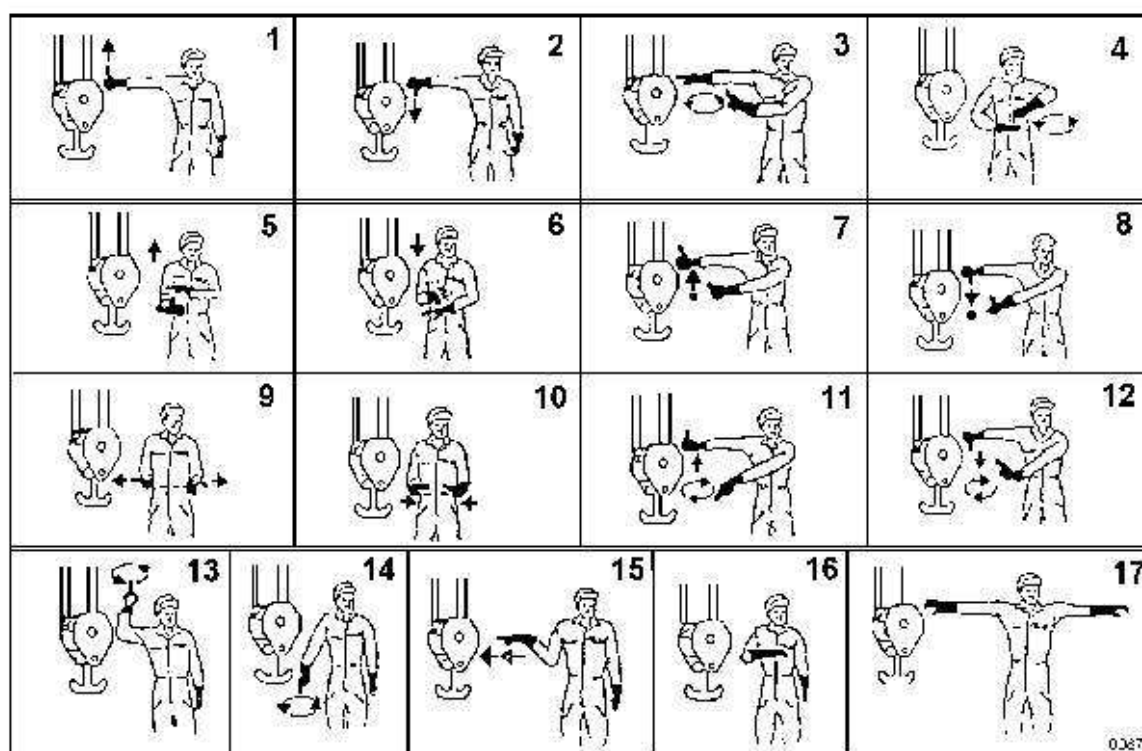

1	Raise boom	10	Retract boom
2	Lower boom	11	Raise boom and dump load
3	Hoist load slowly	12	Lower boom and hoist load
4	Release load slowly	13	Hoist load



5	Raise boom slowly	14	Dump load
6	Lower boom slowly	15	Slew load in this direction
7	Raise boom and hold load	16	Stop everything
8	Lower boom and hold load	17	Stop! End of work movement
9	Extend boom		

### Grounding



Both the mobile crane and its load may under certain circumstance become electrically charged during operation. This can occur, for example, while working near strong transmitters or high frequency systems.

Electric charging is particularly likely to occur if the support plates of the mobile crane consist of insulating material (plastic) or support plates made of non-insulation material (steel) are supported by insulating materials (e.g. square timbers).

The load may also become electrically charged (e.g. when using lifting gear made from non-conducting materials or synthetic coils).

Therefore, it may be necessary to ground the mobile crane and its load. To do this, a conducting connection must be established between the part to be grounded (mobile crane/load) and the ground.

### Grounding the Mobile Crane

	 <b>DANGER</b>
	<p><b>Danger to life from electric shock!</b></p> <p>There is a danger of electric shock when the mobile crane is not properly grounded.</p> <ol style="list-style-type: none"> <li>1. Avoid electrostatic charging of the mobile crane.</li> <li>2. Ground the mobile crane properly.</li> </ol>

The mobile crane must be grounded before beginning work:

- near high-frequency systems
- near transmitters (radio transmitters, television and radio transmitters etc),

To ground the mobile crane, the following are necessary:

- if not positioned near the mobile crane, a stable, electrically conducting pole approx. 1 m (3.3 ft) long, which is driven into the ground,
- a sufficiently long, electrically conducting cable with at least 16 mm<sup>2</sup> (0.024 in<sup>2</sup>) diameter,
- Screw clamps, or nuts and disks for fastening the parts to each other.

Procedure:

1. Drive the grounding rod at least 0.7 m (2.3 foot) into the ground.
2. In order to make the ground around the ground rod more conductive, it must be dampened well.

**The ground resistance depends on the contact surface of the grounding rod and the condition of the ground material.**

3. Connect one end of the grounding cable with the grounding rod.
4. Fasten the other end of the grounding cable on the back, right-hand side of the mobile crane on the welding stud (5) between disc and nut.

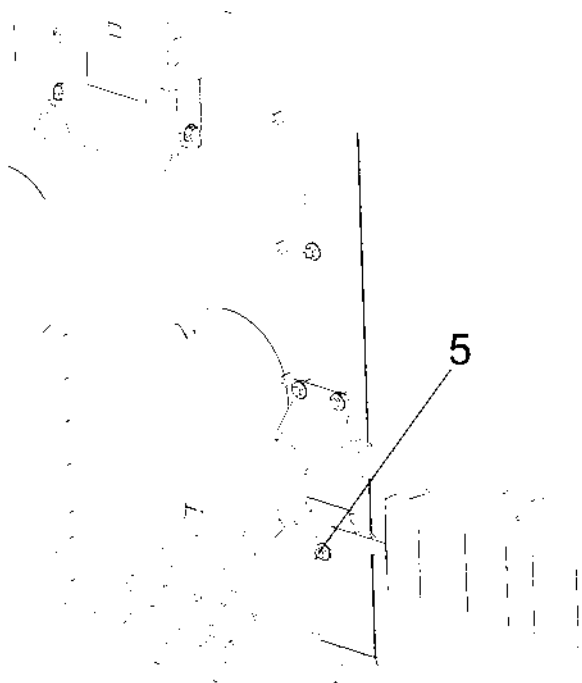

09143

	The connection between the mobile crane and the ground must be free of faults and conducting well.
--	--

If it is possible to connect to a grounding strip or concrete footing ground, this form of grounding should be used.

### Grounding the Load

	<b>DANGER</b>
	<p><b>Danger to life from electric shock!</b></p> <p>There is a danger of electric shock when the load is not properly grounded.</p> <ol style="list-style-type: none"><li>1. Avoid electrostatic charging of the load.</li><li>2. Ground the load properly.</li></ol>

The load must be grounded before beginning work:

- near high-frequency systems,
- near transmitters (radio transmitters, television and radio transmitters etc).

The load can become electrically charged even if the mobile crane is grounded.

To ground the load, the following are necessary:

- if not positioned near the mobile crane, a stable, electrically conducting pole approx. 1 m (3.3 ft) long, which is driven into the ground,



- a sufficiently long, electrically conducting cable with at least 16 mm<sup>2</sup> (0.024 in<sup>2</sup>) diameter,
- an electrically conducting metal rod with an insulated handle, with which the load can be touched,
- Screw clamps, or disks and nuts for fastening the parts to each other.

Procedure:

1. Drive the grounding rod at least 0.7 m (2.3 ft) into the ground.
2. In order to make the ground around the ground rod more conductive, it must be dampened well.



**The ground resistance depends on the contact surface of the grounding rod and the condition of the ground material.**

3. Connect one end of the grounding cable with the grounding rod.
4. Connect the other end of the grounding cable with the metal rod with the insulated handle.
5. The load must first be touched with the grounding rod before touching the load.



	 <b>DANGER</b>
	<p><b>Danger to life from electric shock!</b> The grounding rod may only be held by its insulated handle during earthing. There is a risk of electric shock.</p> <ol style="list-style-type: none"> <li>1. Hold the grounding rod by its insulated handle.</li> </ol>

### Carrying Persons

The mobile crane is not intended to carry persons!

	 <b>WARNING</b>
	<p><b>Risk of accident!</b> The persons riding can fall from the load. This could be fatal.</p> <ol style="list-style-type: none"> <li>1. Do not carry any persons with the load or with the load lifting devices.</li> </ol>

### Crane Operation during Storms

	 <b>DANGER</b>
	<p><b>Lightning strike!</b> Lightning strike could cause serious or fatal injuries to persons.</p> <ol style="list-style-type: none"> <li>1. Ensure that nobody is directly next to the mobile crane during a storm.</li> </ol>

During weather conditions which could lead to lightning strikes, the following points must always be adhered to:

- immediately discontinue working with the crane,

- put down the load,
- retract and lower the boom,
- Switch off the superstructure engine and exit the crane cab.

### Checks after Lightning Strike

	<b>NOTICE</b>
	<p><b>Damage to the mobile crane from lightning strike!</b></p> <p>Electronic, electrical and even mechanical components of the mobile crane can be damaged by lightning strike.</p> <ol style="list-style-type: none"> <li>1. The function of the electrical and electronic parts should be checked after a lightning strike.</li> <li>2. The rotary joint should be checked for damage and normal operation.</li> </ol>



### Welding on the Load

	<b>NOTICE</b>
	<p><b>Damage caused by welding on the load!</b></p> <p>When welding on the load, the flow of high current can cause spark overs to the mobile crane and therefore lead to damage.</p> <ol style="list-style-type: none"> <li>1. The load should be grounded.</li> </ol>

During welding on the load, the ground terminal of the welding machine must be fastened directly to the load to avoid currents flowing over the hoisting rope or mobile crane.

### Working near Overhead Electric Lines

Severe injuries can occur when working with cranes near overhead electric lines if the mobile crane touches the lines or comes too near to them with the boom or the load.

	<b>⚠ DANGER</b>
	<p><b>Electric shock!</b></p> <p>Electricity transfer could cause serious or fatal injuries to persons.</p> <ol style="list-style-type: none"> <li>1. Observe the minimum safe distance to live overhead electric lines.</li> </ol>
	<p>While at voltages of less than 1,000 V there is usually only a danger from direct contact with the overhead lines, at voltages of over 1,000 V electricity can transfer just from being near the lines and cause an accident.</p>

The following specifications must be observed:

- Find out about the nominal voltages of any overhead lines nearby from the responsible electricity company before beginning work.
- Work near overhead lines should only take place with a signaler. Decide on the safe distances and the hand signals with the signaler.
- All persons working in the working range must wear protective clothing for this duration, e.g. plastic gloves and upper body clothing without metal connections, shoes with rubber or leather soles.
- Do not place loads under electric lines or near power sources.
- Carry out crane movements slowly and with utmost care.



	<b>NOTICE</b>
	<p><b>Safe distance to high voltage cables!</b> The regulations of the country of use must be obeyed.</p>

A safe distance to the live wires must be maintained under all circumstances.

**In Germany, VDE directive 0105 applies:**

Nominal voltage	Minimum distance to be observed
up to 1000V (1 kV)	1 m
from 1,000 V to 110,000 V (from 1 kV to 110 kV)	3 m
from 110,000 V to 220,000 V (from 110 kV to 220 kV)	4 m
from 220,000 V to 380,000 V (from 220 kV to 380 kV)	5 m
unknown nominal voltage	5 m

### Procedure after Current Transfer to Mobile Crane

	 <b>DANGER</b>
	<p><b>Current transfer, mobile crane is still live!</b> After current has transferred the mobile crane may still be live.</p> <ol style="list-style-type: none"> <li>1. Keep calm and do not leave the crane cab.</li> <li>2. Warn those outside of the danger, tell them to stay where they are and under no circumstances to touch the mobile crane.</li> <li>3. Proceed as follows.</li> </ol>

If, despite taking every precaution, the crane touches overhead lines or comes close enough for the current to jump over, the following measures should be taken:

- if possible, bring the mobile crane out of the danger zone by turning it away or moving the boom.
- Ask those outside to have the electricity turned off.
- However, if it is still necessary to vacate the crane cab, never touch the mobile crane and the ground at the same time. Do not climb down, but jump to the ground.
- Move away from the mobile crane with small steps.

### Checks after Current Transfer



	<b>NOTICE</b>
	<p><b>Damage to the mobile crane after current transfer!</b></p> <p>Electronic, electrical and even mechanical components of the mobile crane can be damaged by current transfer.</p> <ol style="list-style-type: none"><li>1. The function of the electrical and electronic parts should be checked after current transfer.</li><li>2. The rotary joint should be checked for damage and normal operation.</li></ol>

### Working near Transmitters

If there is a transmitter near the building site, it must be assumed that there are strong electromagnetic fields present.

People and objects can be harmed directly by electromagnetic fields due to:

- danger of combustion and burning due to heating,
- effects on human organs due to heating,
- damage to objects and/or parts,
- creation of electric arcs or sparks.

	 <b>DANGER</b>
	<p><b>Effect of electromagnetic fields!</b></p> <p>Electromagnetic fields can cause damage.</p> <ol style="list-style-type: none"><li>1. Discussion with the operator of the transmitter should take place before using the crane near a transmitter.</li><li>2. It is also necessary to conduct discussions with a high-frequency specialist.</li></ol>

The regulations of the country of use must be obeyed.



When working with a crane in the region of high frequency radiation (HF radiation) from a transmitter, increase work protection and particular accident prevention regulations must be observed by crane operators and slingers:



- Every mobile crane used must be fully grounded. It should be checked whether all parts, e.g. ladders, crane cab, etc. are grounded.
- All persons in the working area must wear protective wearing during this time which will protect them from burns. Synthetic gloves and tops, without metal fastenings, are suitable for example.
- Contact with other crane loads is forbidden (arcs).
- There must be an insulator between the sling gear and bottom block. This insulator may not be removed under any circumstances.
- Contact with the hoisting rope above the insulator is forbidden.

- If contact with hoisting ropes does occur, a supervisor should be informed immediately. Notches caused by fire reduce the bearing capability of hoisting ropes. Therefore a check of the hoisting rope should be carried out immediately.
- To reduce the exposure to high frequency, loads should be transported horizontally where possible.
- This should first be grounded when working on the load.
- The "temperature" of a part can be determined with a suitable measuring instrument. If, for example, 500 V can be measured at a distance of 1-2 cm (0.4-0.8 in) to the part, the part may not be touched with bare hands.
- The warming of parts affected by high frequency depends on their size – the larger they are, the warmer they will be.
- The loads lifted with the mobile crane may not be touched with unprotected body parts after hoisting or setting down.
- Explosive materials (for example, fuels) may not be used nearer than 7 m (23 ft) from places where sparks could be generated (for example, when working with large metal parts). Only insulating materials may be used for refueling.
- The supervisor must be notified immediately of any particular incidents and accidents.

### Interrupting Crane Work

When leaving the mobile crane, care must be taken that no danger arises for people and surroundings due to unforeseen events.





	 <b>DANGER</b>
	<p><b>Swinging load!</b> A lifted load may start to move. This could cause serious or fatal injuries to persons.</p> <ol style="list-style-type: none"> <li>1. The load should be set down if work is interrupted.</li> <li>2. The crane cab may not be vacated as long as the load is lifted.</li> <li>3. Set up work sequences such that there are no long lifting times of the load.</li> </ol>

	 <b>DANGER</b>
	<p><b>Unforeseen events!</b> Unforeseen events can happen. They could cause the status of the mobile crane to become unsafe and tip over or damage parts.</p> <ol style="list-style-type: none"> <li>1. The mobile crane must always be under control.</li> </ol>

Unforeseen events can include:



- derrick cylinders, counterweight cylinders or outrigger cylinders falling down,
- undermining of the support,
- bad weather,
- melting ice under the support plates due to the effect of pressure,

- ground giving way due to changed environmental influences e.g. rain,
- vandalism.

	The mobile crane must be checked regularly if it has to be left equipped over night, for example. It must be ensured that the mobile crane can be made safe if an unexpected incident should occur.
	<p style="text-align: center;"> <b>WARNING</b></p> <p><b>Risk of accident!</b> If the mobile crane cannot be checked regularly while work is paused, it must be dismantled.</p>
	<p style="text-align: center;"><b>NOTICE</b></p> <p><b>Corrosion on hydraulic cylinders!</b> The mobile crane must be dismantled if it is out of operation for a longer period. Aggressive environmental conditions (e.g. oceanic climate) can corrode the piston rods of the hydraulic cylinders.</p> <ol style="list-style-type: none"> <li>1. Dismantle mobile crane.</li> <li>2. Retract hydraulic cylinders completely.</li> <li>3. Put corrosion protection measures in place for exposed parts.</li> </ol>

### Resuming Crane Work

The crane operator has a duty to check the mobile crane and all of its safety devices when resuming work with the crane.

	<p style="text-align: center;"> <b>WARNING</b></p> <p><b>Incorrectly set load automatic safe load indicator!</b> If the automatic safe load indicator is set incorrectly, the mobile crane could become overloaded when it takes up a load.</p> <ol style="list-style-type: none"> <li>1. The setting of the automatic safe load indicator should be checked before resuming work with the crane. Reenter the setting condition if required.</li> </ol>
---	--

### Lifting work with several mobile cranes

It is dangerous to lift a load using 2 or more cranes. Lifting work with several cranes has high risks due to deviations in the gravity centre such as crane overturning, dropping of lifted loads, and damage to the boom.



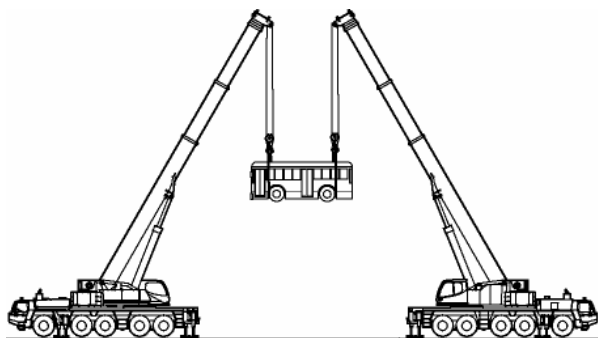



The following points must be observed

- The procedure should be approved by all the persons involved.
- A supervisor should be named and his/her instructions must be followed. Provide all employees with the communication equipment if required.
- The mobile crane must be properly installed and supported.

### 2.2.5 Errors during Crane Work

	 <b>DANGER</b>
	<p><b>Risk of accident!</b></p> <p>Errors during crane work can lead to serious accidents. This could cause serious or fatal injuries to persons.</p> <p>1. The following points must be avoided.</p>

Causes and errors during crane operation:

- Mobile crane is not equipped in accordance with its load and the appropriate lifting capacity table,
- Support under the support plates is not in accordance with the prevailing ground conditions,
- Support is not located centrally under the support plates,
- Outrigger cylinders are extended to the end position,
- Mobile crane is not horizontally aligned,
- Tires are not clear of the ground,
- Mobile crane is too close to the edge of slopes or trenches,
- Hydraulic axle suspension is not blocked,
- Ground inclines or unevenness is too great to travel on wheels,
- Slacking of the rope at the hoisting winch,
- Errors while rigging the load,
- Improper use of the mobile crane, e.g. by pulling unevenly or cutting loads loose,
- Slewing or stopping the load too quickly,
- Not taking account of wind influences on load and mobile crane,
- Overload safeguard not set to actual setup condition of the mobile crane,
- Overload safeguard taken out of operation,
- Load or jib length not in accordance with relevant lifting capacity chart,
- No clear view of load,

- Lifting too high loads over the luffing cylinders,
- Safe distance to live overhead lines not kept to.

### 2.2.6 Ending Crane Work

Before ending crane work, the following points must be observed:

- The load must be set down.
- All telescopes must be retracted and the boom stowed in the boom store.
- The slew gear brake must be activated.
- The heating must be turned off.
- The engine must be turned off and the ignition key removed.
- The battery main switch on the superstructure must be switched off.
- The parking brake in the carrier must be engaged.
- All doors and covers must be locked.
- The mobile crane must be secured against unauthorized access. It must be ensured that no one is in the driver's cab or crane cab.
- It must be ensured that the mobile crane cannot roll away, e.g. with chocks.

#### Chocks

The mobile crane is equipped with (folding) chocks in line with the legal requirements. For transport, fold up the chocks and stow them securely.

Fold out the chocks to prevent the mobile crane from rolling away.

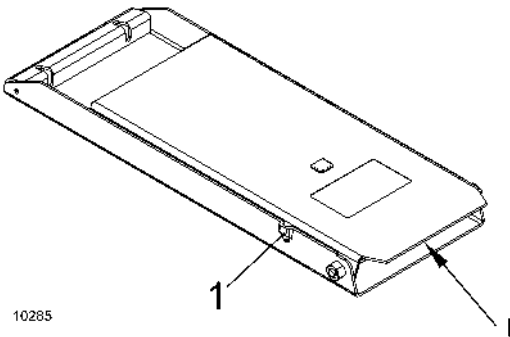
	<b>⚠ CAUTION</b>
	<p><b>Unfolding the chocks</b></p> <p>The folding chock automatically folds out into its working position when the lock (1) is released. This involves a risk of crush injuries.</p> <p>1. Do not reach into the marked area (!).</p>  <p>10285</p>



1. Release the lock (1).



2. The chock (2) automatically unfolds into its working position.



Place the unfolded chocks (2) tightly against the wheels (3) on the downhill side.



## 3 Operation

### 3.1 Crane components of superstructure

#### 3.1.1 Assemblies, components – installation place

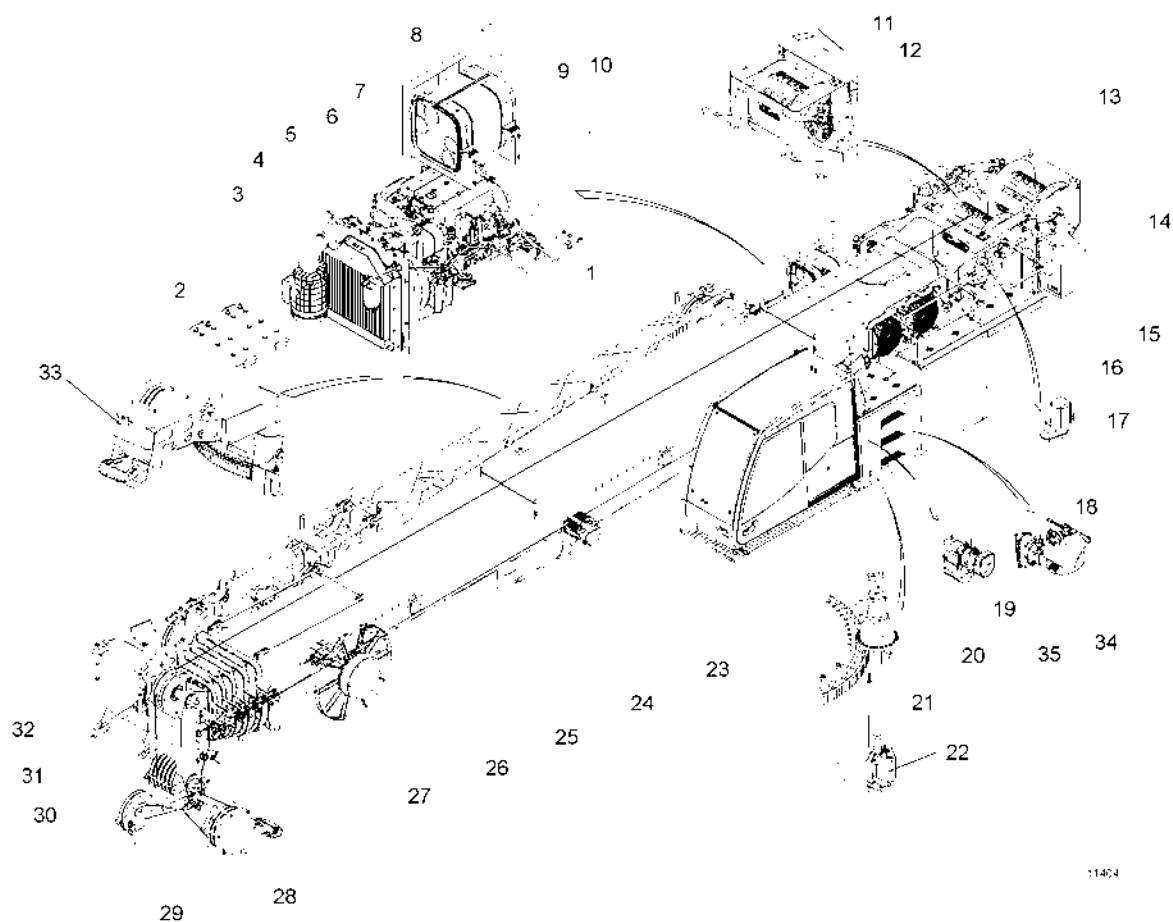

1	Jib*)	19	Auxiliary heater
2	Batteries	20	Access step
3	Air cleaner	21	Rotating mechanism drive
4	Radiator	22	Swing mechanism lock*)
5	Fuel filter	23	Crane cab
6	Coolant expansion tank	24	Derrick cylinder
7	Engine	25	Boom
8	Exhaust system	26	Hoisting rope
9	Hydraulic pumps	27	Hose reel, hydraulic hoses, hydraulic adjustment of jib*)
10	High-pressure filter	28	Bottom block
11	Hoisting gear 1	29	Single top
12	Drive of hoisting gear 1	30	Sheaves for lower boom head

13	Hoisting gear 2*)	31	Boom head
14	Counterweight	32	Sheaves for upper boom head
15	Counterweight cylinder	33	Bottom block holder*)
16	Railing	34	AdBlue® tank
17	Central lubricating system	35	AdBlue® pump
18	Oil cooler/additional oil cooler*)		

#### 3.1.2 Crane cab

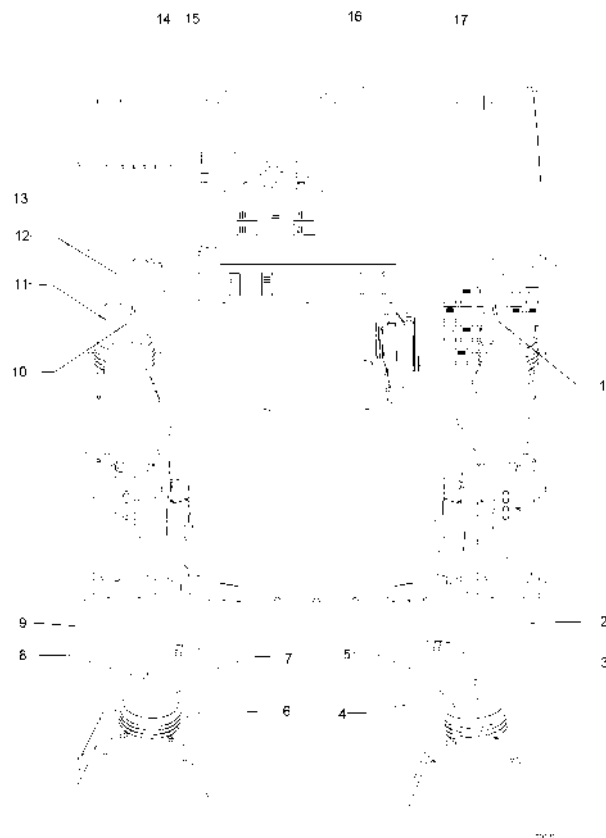

1	Right crane control lever	10	Left crane control lever
2	Rocker switch for the 2nd winch*)	11	Ashtray
3	Hoisting gear rotation indicator	12	Swivelling bracket
4	Signal horn pushbutton	13	Radio
5	Fast-approach circuit pushbutton	14	Superstructure emergency-stop pushbutton
6	Signal horn pushbutton	15	Foot pedal of the slewing gear brake
7	Fast-approach circuit pushbutton	16	Accelerator pedal of the superstructure engine
8	Hoisting gear rotation indicator	17	Boom telescope state monitor
9	Rocker switch for the slewing gear brake		

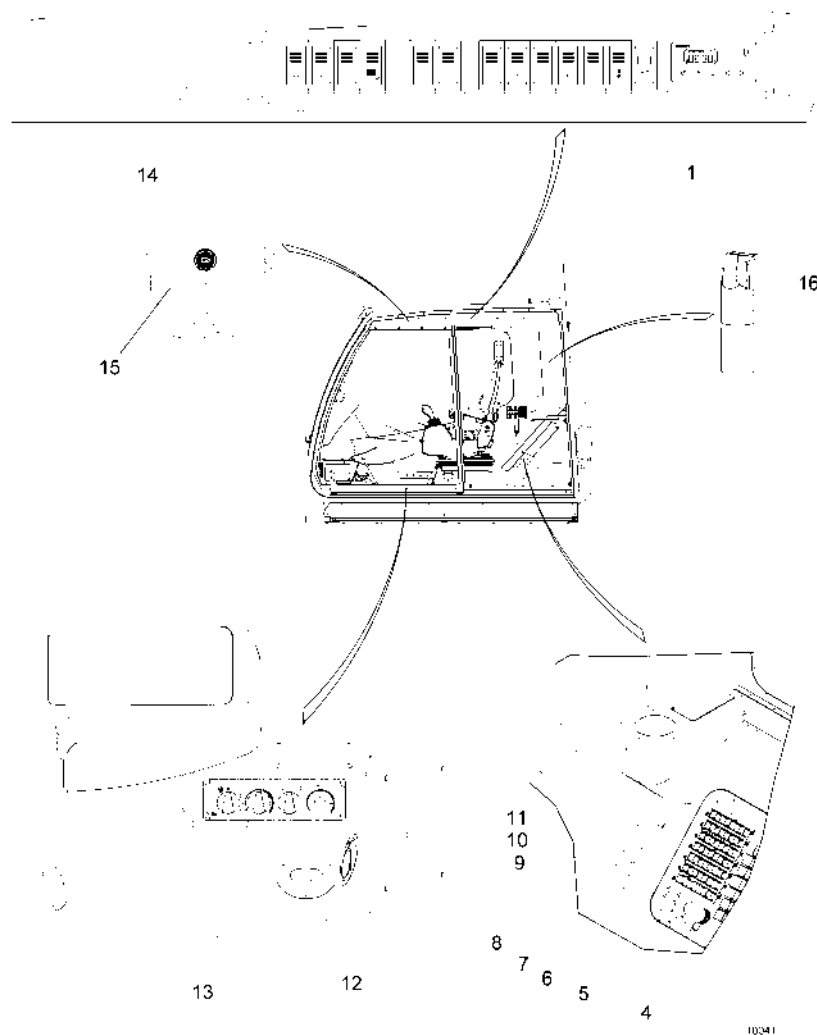

1	Instrument panel	9	12V DC plugbox
2	Fuses	10	24V DC plugbox
3	Relay	11	Key-operated switch for automatic safe load indicator overriding
4	Engine diagnostics plug	12	Superstructure locking bolts
5	Automatic safe load indicator diagnostics plug	13	Operating element heater/ventilation, air conditioning system*)
6	Hourmeter for hoisting gear 2*)	14	Interior lighting
7	Hourmeter for hoisting gear 1*)	15	Ventilator*)
8	Engine hourmeter	16	Fire extinguisher*)

3.1.3 Operating elements

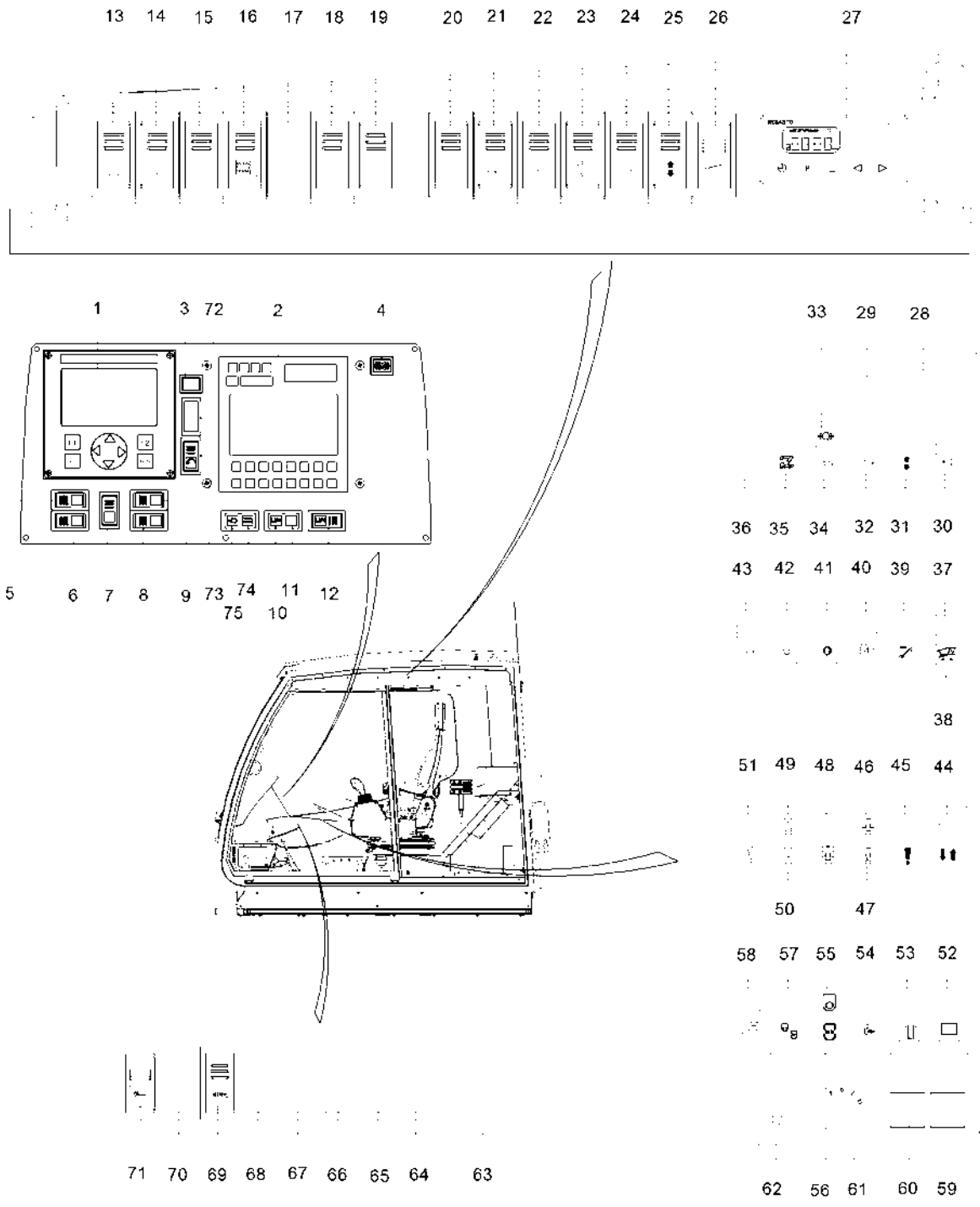

13146



**Display, indicator and warning lamps**

10	(ye) torque limiter active (LIM)	49	(rd) 'Counterweight not up' warning lamp
33	(rd) 'Swing mechanism free run' warning lamp	50	(gn) 'Counterweight down' pilot lamp
34	(gn) 'Swing mechanism locked*') pilot lamp	55	(gn) Pilot lamp for the telescope cylinder lock indicator
37	Unoccupied	56	(gn) Pilot lamp for the telescope lock indicator
38	(rd) Jib, luffing cylinder not retracted*)	74	(ye) Check engine lamp (CEL)
46	(gn) 'Counterweight locked' pilot lamp	75	(ye) Fill level and quality monitoring of AdBlue® (DEF)
47	(gn) 'Counterweight unlocked' pilot lamp		

#### Switch, rocker switch (WS) and rocker tip switch (WT)

5	WT for extending/retracting the front-left outrigger beam/outrigger cylinder	32	(gn) WS+) for activating the slewing mechanism lock
6	WT for extending/retracting the rear-left outrigger beam/outrigger cylinder	35	(gn) WS+) boom – removal*)
7	WS for preselecting the outrigger beam/outrigger cylinder	36	Free
8	WT for extending/retracting the rear-right outrigger beam/outrigger cylinder	39	(gn) WS+) for activating the jib derricking*)
9	WT for extending/retracting the front-right outrigger beam/outrigger cylinder	40	(gn) WS+) for activating the hoisting gear 2*)
11	Unoccupied	41	(ws) WS for displaying the lifting height of hoisting gear 2*)
12	(ye) WT - override torque reduction	42	(ws) WST for displaying/resetting the lifting height of hoisting gear 1
13	(gn) WS+) for aircraft warning lamp*)	43	(rd) WS+) for releasing the slewing range limit
14	(gn) WS+) for mirror heater on the boom*)	44	(gn) WS for activating the winch rotation indicator
15	(gn) WS+) for the central lubrication system	45	(rd) WT for overriding the counterweight/crane control
16	(ye) WS for working floodlights of hoisting gear*)	48	(gn) WT for locking/unlocking the counterweight
17	Unoccupied	51	(gn) WT for lifting/lowering the counterweight
18	(gn) WT for adjusting the working floodlights*)	52	(gn) WT for the telescope monitor
19	(gn) WS for working floodlights on the base boom	53	(gn) WT for the lift adjuster
20	(gn) WS for instrument illumination/ working floodlight in the crane cab	54	(gn) WT for releasing the lock
21	(gn) WS for the roof panel wiper	57	(gn) WS for preselecting the telescope/cylinder
22	(gn) WS for the windscreen wiper	58	(rd) WS+) for emergency telescope function
23	(gn) WT for the washer	62	(rd) WT for stopping the superstructure engine
24	(gn) WT for adjusting the step	69	(gn) WT for changing the speed of the carrier engine
25	(gn) WT for adjusting the cockpit	71	(gn) WS+) for activating the carrier control
26	(gn) WS+) battery main switch	72	Free
30	(gn) WS+) for radio control*)	73	(rd) WST superstructure engine speed regulation
31	(gn) WT for locking/unlocking the swing mechanism*)		

## Miscellaneous

1	Cockpit-Graphic-Control System (CGC)	61	DS for the ignition starter switch of the superstructure engine
2	Automatic safe load indicator	63	Unoccupied
3	Central warning display of the Cockpit-Graphic-Control System	64	Unoccupied
4	Warning buzzer of the automatic safe load indicator	65	Unoccupied
27	Auxiliary heater control device	66	(rd) Warning lamp for length sensor override *)
28	Unoccupied	67	Unoccupied
29	Unoccupied	68	Unoccupied
59	Key-operated switch for overriding outrigger length sensor *)	70	Unoccupied
60	Key-operated switch for overriding the anti-twoblock device		

## Abbreviations



Pilot lamps = (gn) green Indicator lamps = (ye) yellow, (or) orange, (bl) blue, (ws) white Warning lamps = (rd) red	WS+) = rocker switch with a function lamp WS = rocker switch WT = rocker tip switch WST = rocker switch DS = rotary switch
---	--

## 3.2 Before starting work

Various checks must be carried out before starting work.

The detailed description of the following checks is given in the chapters "Superstructure operating Manual" and "Servicing and maintenance of superstructure".

## 3.2.1 Checking the lights

	 <b>WARNING</b>
	<p><b>Missing or non-functioning lighting equipment!</b></p> <p>Contaminated, defective or non-functioning lighting equipment can lead to accidents.</p> <ol style="list-style-type: none"> <li>1. Check the lighting equipment before starting work and clean if required.</li> <li>2. Get defective lighting equipment repaired by experts.</li> <li>3. Contact experts to replace the defective lighting equipment.</li> </ol>

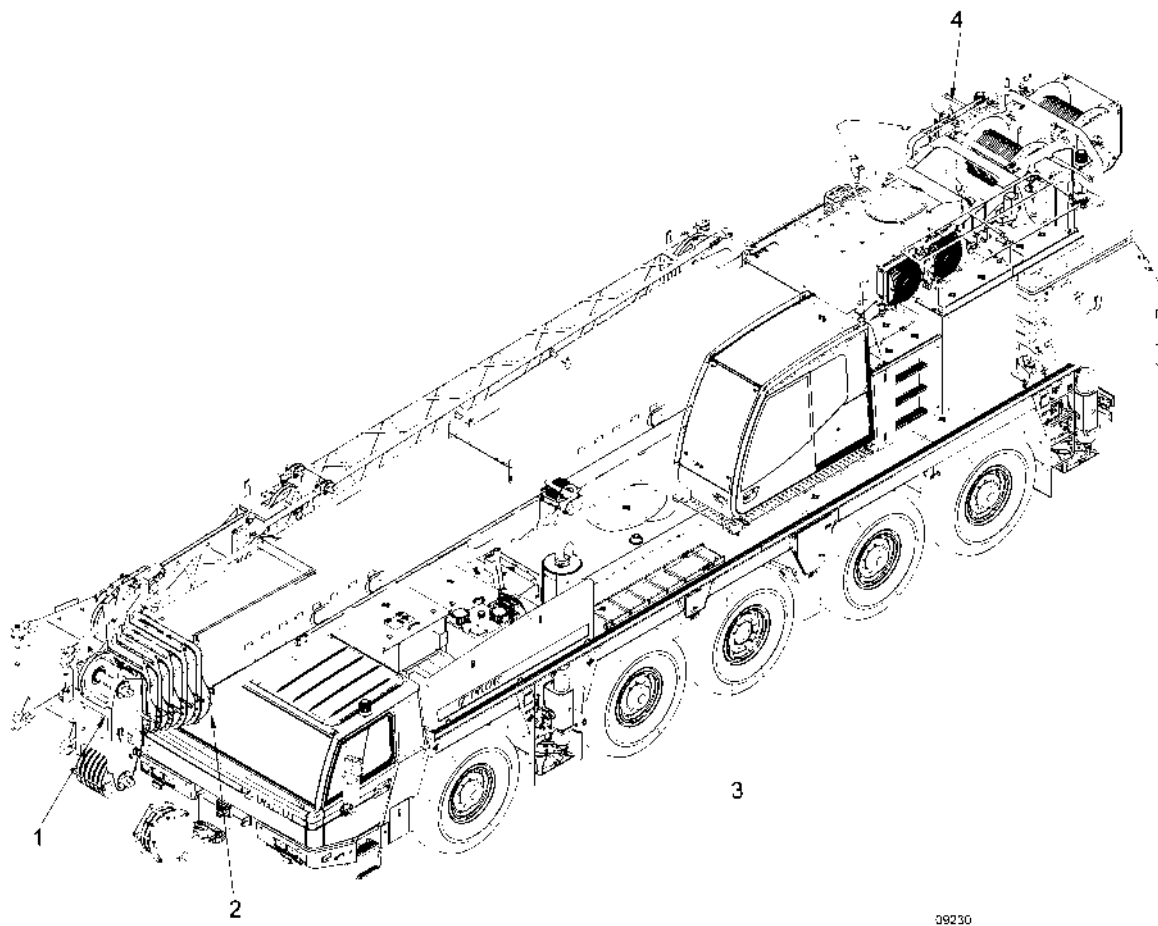

1	Aircraft warning lamp	3	Working floodlights on the crane cab
2	Working floodlights on the base boom	4	Working floodlight on the hoisting gear

### 3.2.2 Checking the oil level

1. Check the oil level of the superstructure engine.
2. Check the oil level in the hydraulic oil tank.



### 3.2.3 Checking the coolant level

	<p><b>! WARNING</b></p>
	<p><b>Risk of scalding due to hot coolant!</b>                  If the filler neck is opened when the coolant is hot, hot coolant may escape from it. This can lead to severe scalding.</p> <p>1. Check the coolant level only when the coolant is cold.</p>



### 3.2.4 Checking the fill quantity of fuel

1. Check the filling level of the fuel tank on the fuel gauge in the superstructure cab.
2. Refuel on time.



### 3.2.5 Cleaning windshields

	 <b>WARNING</b>
	<p><b>Visibility is impaired if windshields are dirty!</b> Dirty windshields can cause accidents.</p> <ol style="list-style-type: none"> <li>1. Clean windshields before starting work.</li> <li>2. Check the fluid level in the tank of the windshield washing system and refill it if necessary.</li> </ol>

### 3.2.6 Checking the hoisting rope



	 <b>WARNING</b>
	<p><b>Risk of hoisting rope breaking!</b> A defective hoisting rope may break. The load may fall.</p> <ol style="list-style-type: none"> <li>1. Check the hoisting rope regularly, see chapter Checking the hoisting ropes.</li> </ol>

### 3.2.7 Checking the bottom block

	 <b>WARNING</b>
	<p><b>Risk of bottom block breaking!</b> A faulty bottom block can break. The load may fall.</p> <ol style="list-style-type: none"> <li>1. Have the bottom block checked regularly by a specialist, see chapter Checking the bottom block.</li> </ol>

## 3.3 Crane cab

### 3.3.1 Cab door

	 <b>WARNING</b>
	<p><b>Cab door not closed properly!</b> The cab door may open when driving. Objects in the crane cab may fall. This may cause accidents.</p> <ol style="list-style-type: none"> <li>1. Close the cab door carefully before traveling.</li> </ol>

#### Opening/closing and locking/unlocking the cab door from outside



#### **CAUTION**

##### **Risk of injuries!**

Fingers may get crushed when closing the cab door.

1. Hold the outer door handle when closing the cab door.
2. For safety, hold onto the grab handle on the superstructure cab.

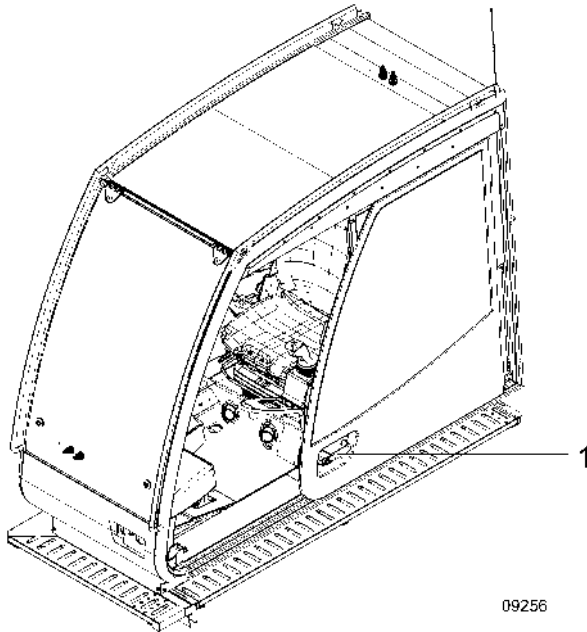

1	Door handle
---	-------------

Opening/closing:

- Press on the knob on the door handle and push or pull the cab door.

Opening:

- Put the key in the door handle lock and turn in an anticlockwise direction

Closing:

- Put the key in the door handle lock and turn in a clockwise direction

## Opening/Closing cab door from inside

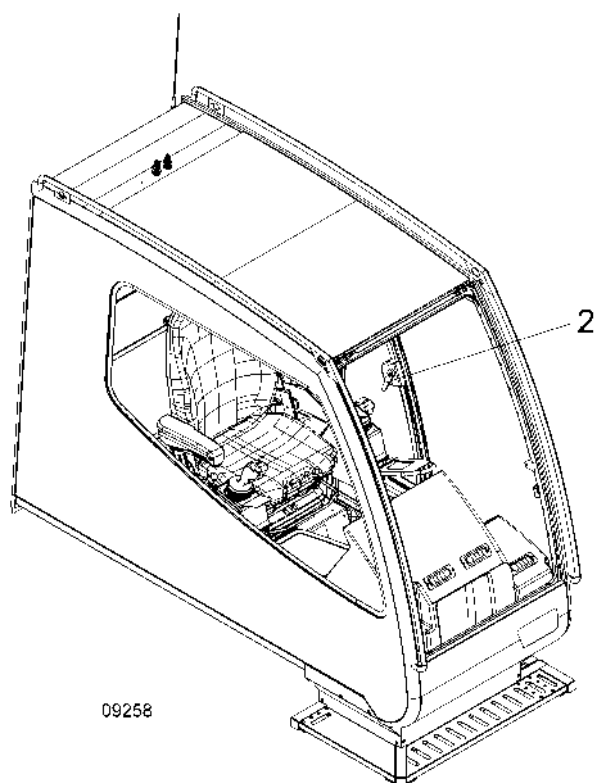

1	Handle
---	--------

- Move the handle in the sliding direction to open or close the cab door.

## 3.3.2 Step adjustment

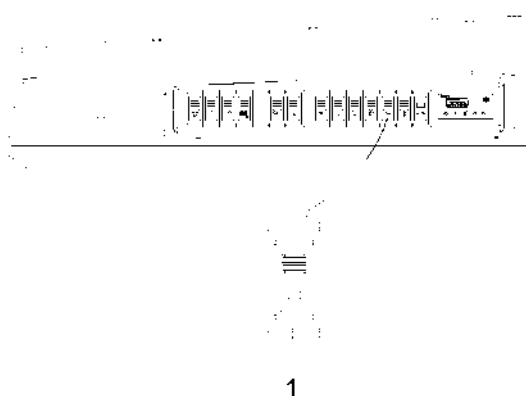
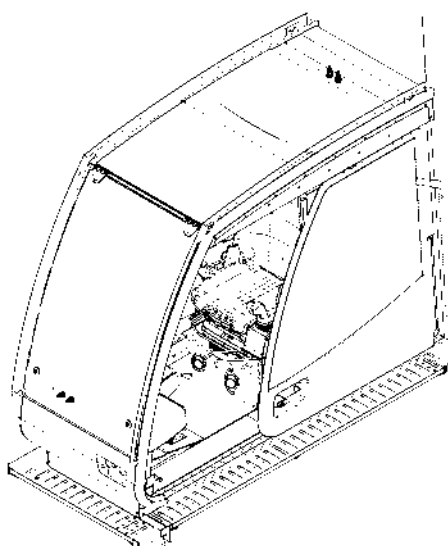

09257

1	Switch for <i>step adjustment</i>
---	-----------------------------------

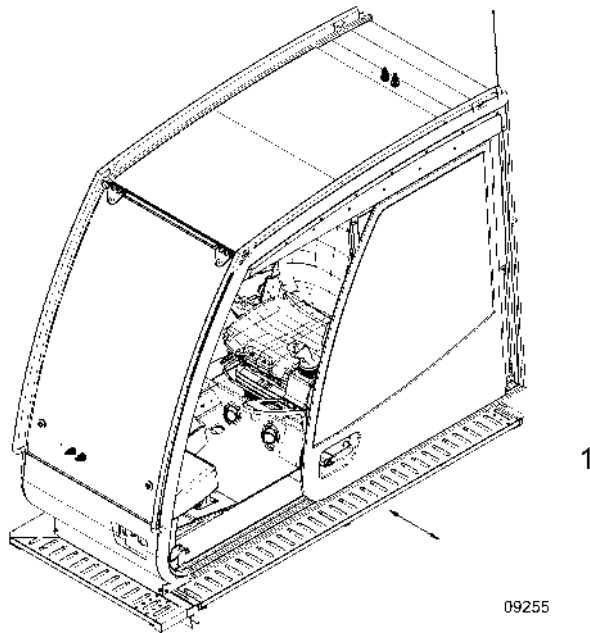

1	Access step
---	-------------

The surface of the access step can be moved outwards to enable a comfortable exit from the crane cab.

1. Press the *step adjustment* switch until the step is extended completely.

### 3.3.3 Opening/closing the window



#### **NOTICE**

**Raindrops may enter the crane cab if the windshields are open.**  
Raindrops may enter the crane cab if windows are open. As a result, control elements may get wet. This may lead to failures or malfunctions.

1. Close all windows when leaving the crane cab.



### Opening/closing the front windshield

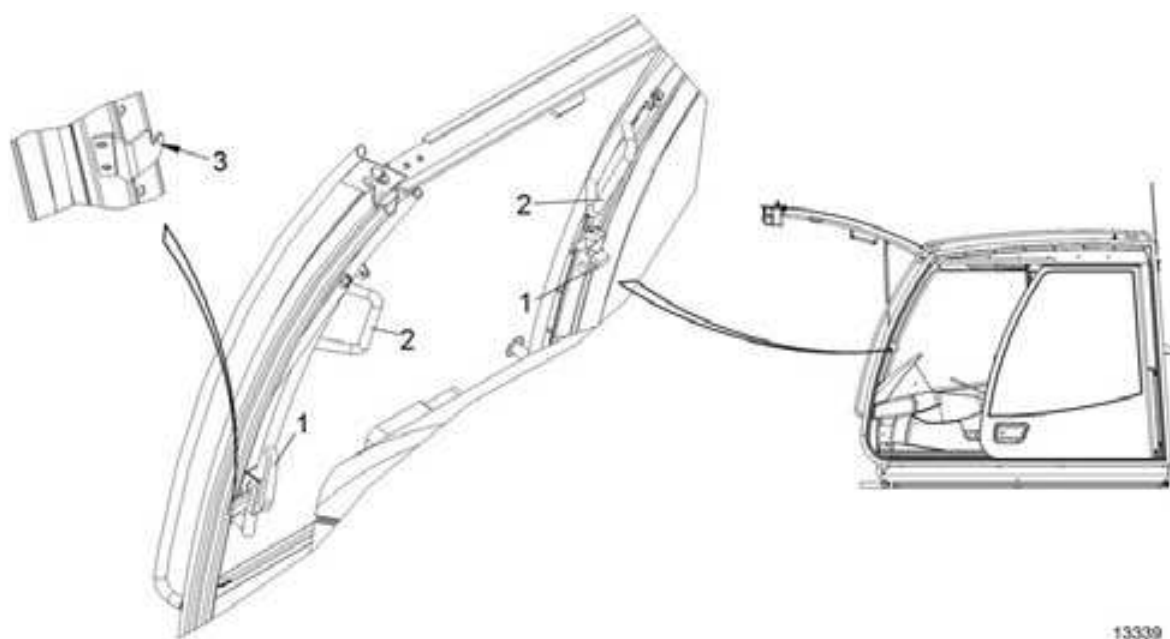

1	Lever	3	Ventilating position
2	Handle		

#### Opening the front windshield

1. Unlock both levers.
  2. Open front windshield with both handles.
- ⇒ The front windshield slews up to the end position.

#### Closing the front windshield

1. Close the front windshield using the handles.
2. Lock both levers.

<b>i</b>	If one cannot exit the superstructure cab through the cab door in case of an emergency, one can exit through the front windshield.
----------	--

#### Ventilating position

1. Unlock both levers.
2. Open the front windshield slightly using the handles.
3. Lock left lever in the holder *Ventilating position*.

### Opening/closing the rear windshield

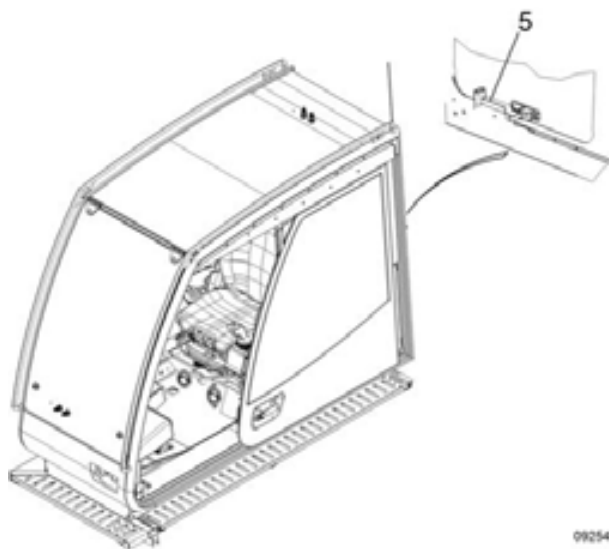

5	Interlock
---	-----------

#### Opening the rear windshield

1. Unlock the lock and open the rear windshield.

#### Closing the rear windshield

1. Close and lock the rear windshield.

### 3.3.4 Adjusting the seat

	<b>WARNING</b>
	<p><b>Unintentional initiation of crane movements.</b></p> <p>When the left seat bracket is folded up, all crane movements are stopped. Unintentional crane movements may be initiated if the left seat bracket is not folded up when entering and exiting. This may result in accidents.</p> <ol style="list-style-type: none"><li>1. The seat bracket on the left must be folded up when entering and exiting the crane cab.</li></ol>

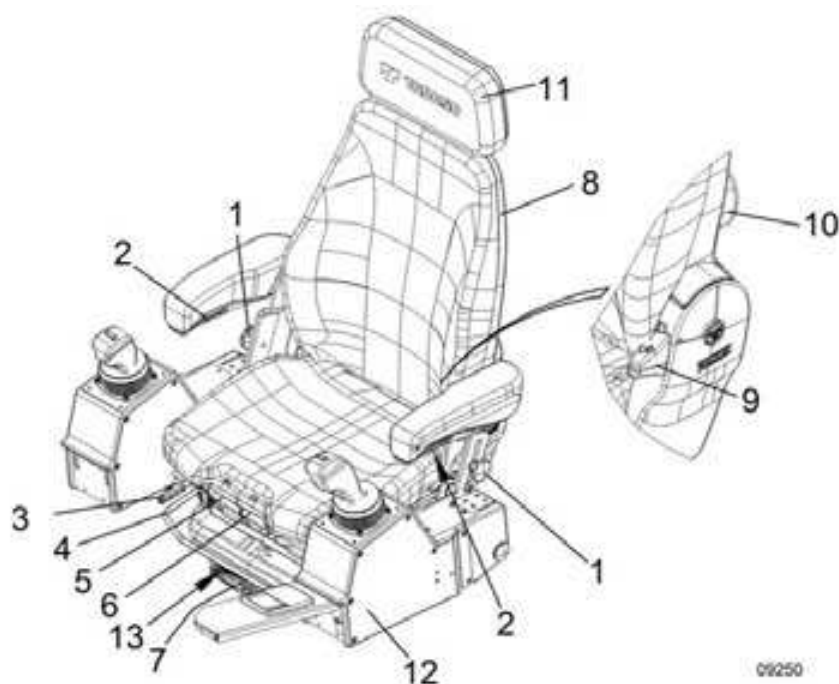

1	<i>Armrest height adjustment lock</i>	8	<i>Seat heater switch</i>
2	<i>Actuator wheel for adjusting the armrest inclination</i>	9	<i>Backrest lever</i>
3	<i>Longitudinal adjustment lever</i>	10	<i>Lumbar support setting wheel</i>
4	<i>Lever for longitudinal adjustment of crane control lever</i>	11	Head rest
5	<i>Seat depth lever</i>	12	Seat bracket left
6	<i>Seat area lever</i>	13	<i>Seat height lever</i>
7	<i>Suspension crank</i>		

### Armrest height adjustment

1. Loosen the *armrest height adjustment lock*.
2. Set the armrest to the desired height.
3. Tighten the *armrest height adjustment lock*.

### Armrest inclination

1. Twist the actuator wheel for *adjusting the armrest inclination*. The armrest inclination will be adjusted.

### Adjust the longitudinal direction of the seat

1. Pull the *longitudinal adjustment lever* up and hold it.
2. Put the seat in the desired position.
3. Release the *longitudinal adjustment lever* and lock the seat in place.

### Adjust the longitudinal crane control lever

1. Pull the lever for *longitudinal adjustment of crane control lever* up and hold it.
2. Put the seat in the desired position.
3. Release the lever for *longitudinal adjustment of crane control lever* and lock the seat in place.

### Adjust the seat depth

1. Pull the *seat depth* lever up and hold it.
2. Put the seat area in the desired position.
3. Release the *seat depth* lever.

### Adjusting the inclination of the seat area

1. Pull the *seat area* lever up and hold it.
  2. Put the *seat area* in the desired position.
  3. Release the *seat area* lever.
- ⇒ The seat area is set.

### Adjusting the suspension

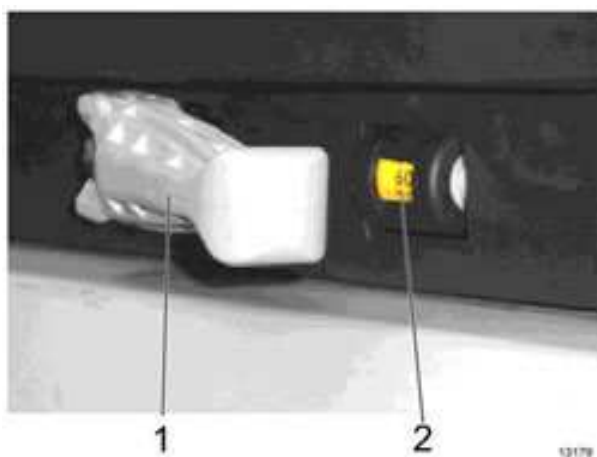

1	<i>Suspension crank</i>	2	Display
---	-------------------------	---	---------

1. Fold out the *suspension* crank.
2. Adjust the weight of the driver on the display by rotating the *suspension* crank clockwise or anti-clockwise.

**NOTICE!** The weight to be set is displayed when the seat is not loaded.

3. Fold up the *suspension* crank.

### Adjusting the seat height

1. Pull the *seat height* lever up and hold it.
  - ⇒ The seat will move up.
1. Push the *seat height* lever downwards and hold it.
  - ⇒ The seat will move downwards.

### Turning on/off the seat heater

1. Press the *seat heater* switch.

### Adjusting the backrest

1. Pull the lever up and hold it.
2. Move the *backrest* forwards or backwards.
3. Release the lever and lock the backrest in place.

### Adjusting the lumbar support

1. Rotate the *lumbar support* wheel to adjust the lumbar support.

### Head rest

The head rest cannot be adjusted. The head rest can be removed by pulling it up.

### 3.3.5 Heater, ventilation, air conditioning system



1	Blower	3	Air supply
2	Temperature	4	Air conditioning system

For information on operation, care and maintenance, see Superstructure cab.

The manufacturer's specifications must be observed.

#### Blower

Air flow regulation:

Blower off.

First stage: low power.

Second stage: medium power.

Third stage: high power.

#### Temperature control

Temperature control stepless.

Cold: left.

Hot: right.

#### Air supply

Upon switchover, the outside air supply is interrupted.

The air circulates in the cab's closed circuit.

#### Air conditioning system

The air-conditioning system can only be operated when the superstructure engine is running.

##### Turning on the air conditioning system:

1. Switch the *blower* to at least stage 1.
2. Turn on the air conditioning system by rotating the *air conditioning system* switch to the right.  
The cooling can be increased by rotating the switch further to the right.  
⇒ The air conditioning system is activated.

**i**

Run the air conditioning system for a few minutes each week during cold and dry periods in winter and if it is not being used frequently. The air conditioning system is not operational if the outside temperature is particularly low.

#### Turning off the air conditioning system:

1. The air conditioning system can be turned off by rotating the *air conditioning system* switch all the way to the left.
- ⇒ The air conditioning system is turned off.

### 3.3.6 Interior lighting

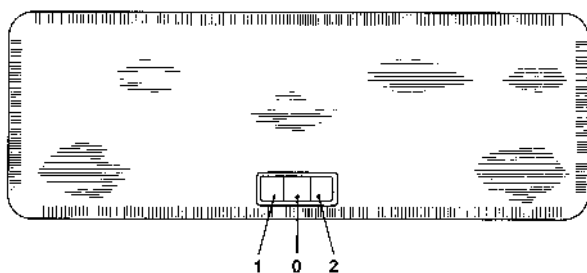

Switch positions:

0 = interior lighting off.

1 = interior lighting on.

2 = no function.

### 3.3.7 Roller sun visor

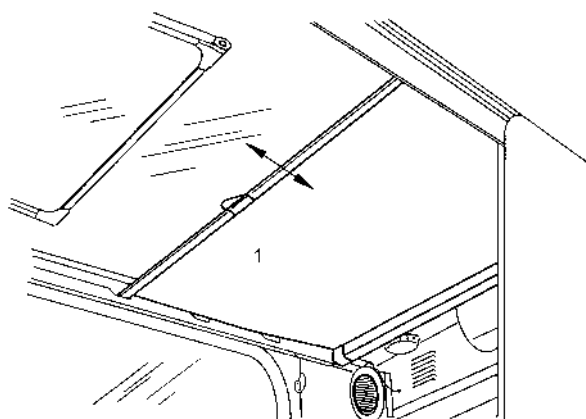

.....

1	Roller sun visor
---	------------------

A roller sun visor is provided for protection against solar radiation through the roof panel. The roller sun visor can be locked at several locking positions.

### 3.3.8 Sun visor

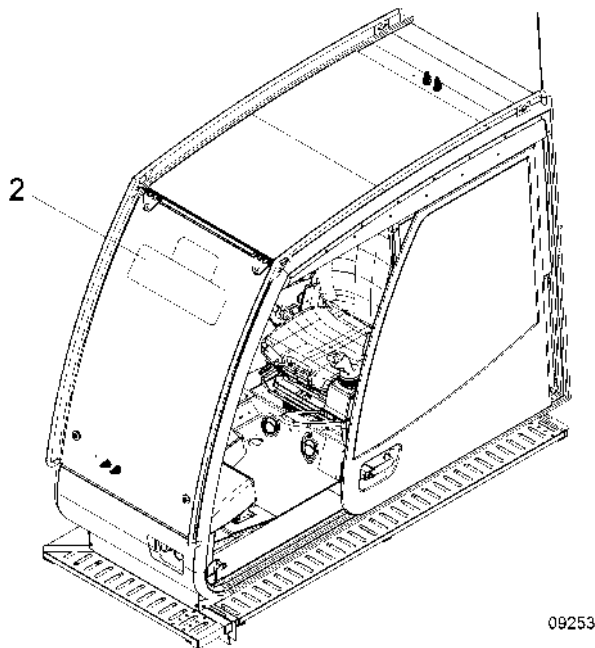

1	Sun visor
---	-----------

A sun visor is provided for protection against solar radiation.  
Set the sun visor such that it is possible to work without any glare.

### 3.3.9 Radio



The radio is installed in the bracket in the crane cab.  
For further information, please refer to the enclosed operating manual of the radio manufacturer.

### 3.3.10 Ventilator\*)



#### CAUTION

**Risk of injuries due to rotating parts!**  
Rotating fan blades may cause injuries.

1. Do not grab the rotor from the rear side.

A fan can be optionally installed in the crane cab for better ventilation. The air flow can be controlled in three stages (off, low and high).



### 3.4 Control & Service System CSS

The superstructure of the mobile crane is equipped with the electronic Control & Service System CSS.

This system executes various monitoring and control functions.

It also executes various operating and steering functions.

	<p><b>! WARNING</b></p>
	<p><b>Operating errors!</b> Operating errors can cause accidents. This can cause injuries to persons, which could sometime be fatal.</p> <ol style="list-style-type: none"> <li>1. Familiarize yourself with the functioning, operation and functioning principles of the Control &amp; Service System before commissioning the superstructure.</li> </ol>

The Cockpit-Graphic-Control System CGC, comprising a monitor and the corresponding operating elements, is installed in the instrument panel of the superstructure.

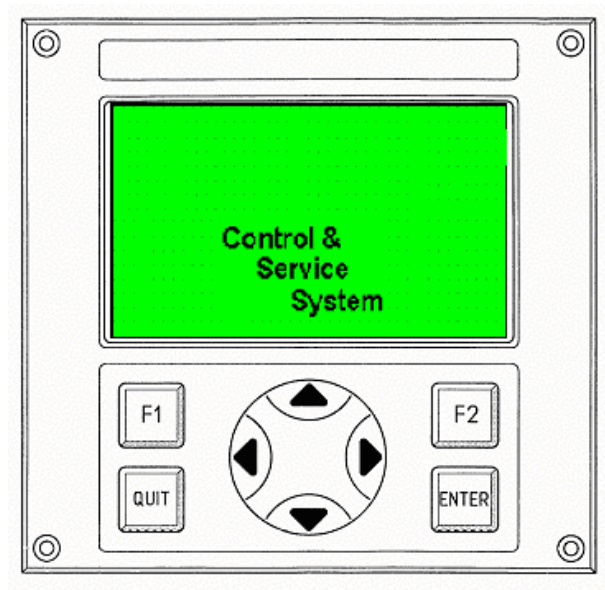









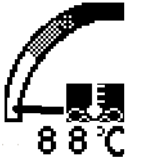





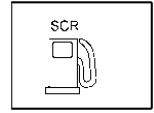
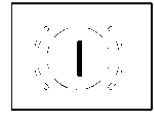

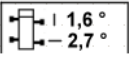

- The key-operated toggle switch in the carrier is at position 2.
- 1. Switch on the battery main switch and the ignition in the superstructure.
  - ⇒ The Start-up screen will appear on the monitor. The system will be loaded.



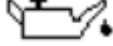

#### 3.4.1 Main screen

The main screen will appear on the monitor after approximately 3 seconds.

#### Information displays and error messages on the main screen

	<p><b>Coolant temperature display:</b> A pointer and a digital display are used to show the coolant temperature of the superstructure engine. The critical range is marked. The normal operating temperature of the coolant is between 80 °C (176 °F) and 90 °C (194 °F).</p>
	<p>The symbol lights up when the critical range is reached. <b>NOTICE! If the coolant temperature exceeds 95 °C (203 °F), the engine is overheated.</b></p> <ol style="list-style-type: none"> <li>1. Interrupt the crane operation and let the superstructure engine run in the idle mode until the coolant temperature drops.</li> <li>2. If the radiator fan fails, stop the engine immediately.</li> <li>3. Check the coolant level and top it up if required.</li> </ol>
	<p><b>On-board voltage:</b> A pointer and a digital display are used to show the on-board voltage of the electrical system. The critical range is marked.</p>
	<p>This symbol lights up when the on-board voltage drops below 17 V. <b>NOTICE! If this indicator lights up while the engine is running, a failure has occurred in the battery charging system.</b></p> <ol style="list-style-type: none"> <li>1. Stop the crane operation to prevent the battery from discharging completely.</li> <li>2. Contact the TADANO After-Sales Service or a specialist workshop.</li> </ol>
	<p><b>Fuel gauge:</b> A pointer and a digital display are used to indicate the fuel tank level of the superstructure. The critical range is marked.</p>
	<p>The symbol starts blinking when the tank volume drops below 60 l (15.8 gal). The symbol lights up constantly when the tank volume drops below 40 l (10.7 gal). <b>NOTICE! If the fuel tank runs dry, air will enter the fuel system and the engine can no longer be started.</b></p> <ol style="list-style-type: none"> <li>1. Refuel on time.</li> <li>2. Bleed the fuel system after running the tank dry.</li> </ol>
	<p>Indicator lights up permanently when the fill level of the AdBlue® tank is low. Indicator flashes when the fill level of the AdBlue® tank is too low.</p>
	<p><b>Compressed air display</b> "Compressed air supply" icon lights up when there is a fault in the compressed air system.</p>
	<p><b>Level:</b> The electronic level shows the current vehicle inclination.</p> <ol style="list-style-type: none"> <li>1. Set up the mobile crane such that it is horizontal.</li> </ol>

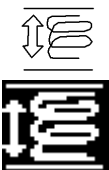
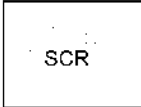
	<p><b>Digital angle display</b> of the current vehicle inclination. Upper value = longitudinal inclination. Lower value = lateral inclination.</p>
	<p><b>Supporting pressure display</b> This shows the current outrigger pressure.</p>
	<p><b>Superstructure locked</b> This symbol appears when the superstructure is locked.</p>
	<p><b>Superstructure can be slewed</b> This symbol appears when the superstructure can be slewed.</p>
	<p><b>Parking brake in the carrier</b> is at the braking position = symbol lights up. The "Carrier parking brake applied" symbol lights up when the mobile crane is hard-braked using the parking brake lever in the carrier or when the supply pressure of the parking brake in the carrier is not adequate.</p>
	<p>Parking brake in the carrier is not in the braking position = symbol appears and flashes inversely.</p>
	<p><b>Hydraulic oil temperature</b> is too high The symbol lights up. 1. Interrupt the crane operation and wait until the hydraulic oil temperature drops.</p>
	<p><b>Hydraulic oil filter</b> is contaminated The symbol lights up. 1. Replace the hydraulic oil filter.  Note: At low oil temperatures, the symbol may light up due to the high viscosity of the hydraulic oil. This symbol disappears when the oil temperature increases.</p>
	<p><b>Oil level</b> in the superstructure engine is too low. The symbol lights up. 1. Interrupt the crane operation and stop the engine immediately. 2. Check the oil level and top it up if required. 3. If the symbol does not disappear even if the oil level is normal, contact the TADANO After-Sales Service or a specialist workshop</p>
	<p><b>Air cleaner monitoring</b> in the superstructure The symbol lights up. 1. Replace the air cleaner.</p>
	<p><b>Fault in the engine or in the engine closed-loop electronics</b> in the superstructure The symbol lights up. 1. Interrupt the crane operation and stop the engine immediately. 2. Contact the TADANO After-Sales Service or a specialist workshop.</p>

	<p><b>CAN error</b> This symbol appears when an error occurs in the connection with the carrier.</p> <ol style="list-style-type: none"> <li>1. Interrupt the crane operation.</li> <li>2. Switch off the ignition and the battery main switch in the superstructure.</li> <li>3. Switch on the battery main switch and the ignition in the superstructure again and start the engine. The CSS system will restart.</li> <li>4. If the display does not disappear, contact the TADANO After-sales Service or a specialist workshop.</li> </ol>
	<p><b>Axles raised</b> This symbol appears as soon as the vehicle is supported and all axles are raised.</p>
	<p><b>Axle suspension locking</b> = symbol lights up. The "Axle suspension locking" symbol lights up when the key-operated switch in the carrier is set to position 2.</p>
	<p><b>Axles suspended</b> = symbol appears and flashes inversely.</p>
	<p><b>AdBlue®</b> Icon flashes, engine off and ignition on. Disappears as soon as the engine runs. The exhaust gas treatment (SCR) icon flashes when there is a fault in the exhaust gas treatment. Have the fault fixed as soon as possible in a specialist workshop.</p>
	<p>Error messages disappear automatically as soon as the error is rectified.</p>

#### Operating elements of the main screen







Switch over to the selecting menu using F2.

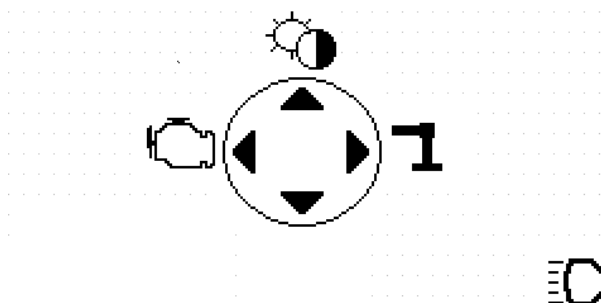





All other keys are without any function.

## 3.4.2 Selection menu



	Contrast/brightness menu
	Outrigger menu
	Engine control menu
	Lighting of the carrier

## Operating elements of the selection menu



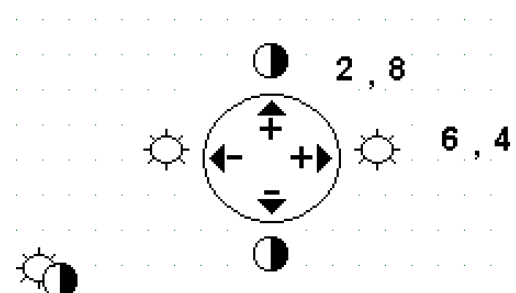

	Press the up arrow key - the Contrast/brightness menu will appear.
	Press the right arrow key - the Outrigger menu will appear.
	Press the left arrow key - the Engine control menu will appear.
 	Press the F2 key: activate/deactivate the lighting of the carrier. Normal symbol – the light is switched off. Inverse symbol – the light is switched on.
	Press the Quit key: back to the main screen.

All other keys are without any function.

## Contrast/brightness menu



This menu can be used to set the contrast and brightness values other than the values preset in the factory.

	Press the right or left arrow key. Setting the brightness of the monitor within the prescribed limits.
	Press the up or down arrow key. Setting the contrast of the monitor within the prescribed limits.
	Press the F1 key: all manually set contrast and brightness values will be deleted. The preset initial settings will be activated.
	Press the Quit key: back to the selection menu.
	The last manually-set contrast and brightness values are retained even after switching off the ignition.

All other keys are without any function.



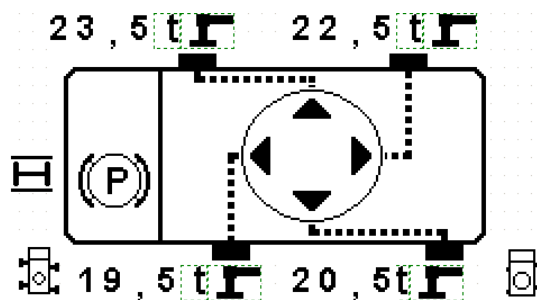







#### Outrigger menu



This menu can be used to actuate the outrigging of the carrier from the superstructure.





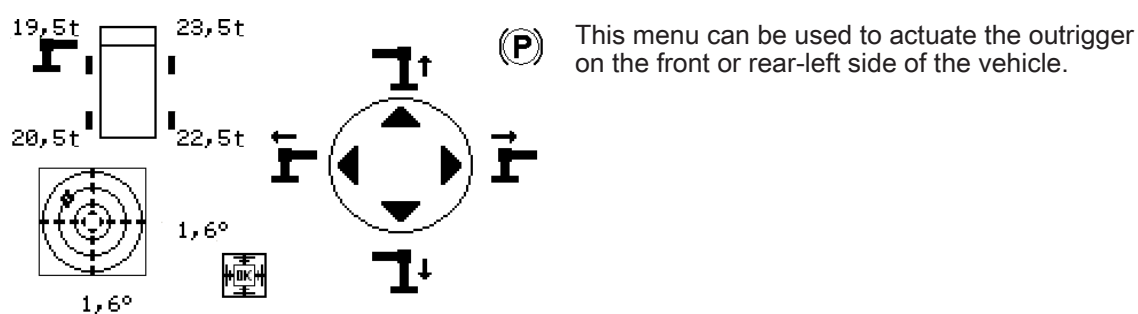

- Individual outriggers can be selected to actuate the corresponding outrigger beams and outrigger cylinders.
- Only the selected outrigger cylinders can be actuated when two, three or four outriggers have been selected.
- The mobile crane can be brought to the leveled position by selecting all four outriggers

## Selecting an outrigger

	Press the up arrow key - the front-right outrigger will be selected.
	Press the left arrow key - the front-left outrigger will be selected.
	Press the down arrow key - the rear-left outrigger will be selected.
	Press the right arrow key - the rear-right outrigger will be selected.
 	Press the F1 key: all four outriggers will be selected.
 	Press the F2 key: All the outriggers that were selected earlier will be de-selected.
	Press the ENTER key: Actuate the selected outriggers and switch over to the corresponding screen.
	Press the Quit key: back to the selection menu.

## Left outrigger control screen

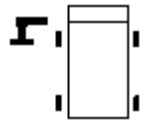
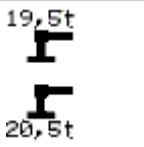
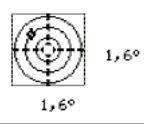





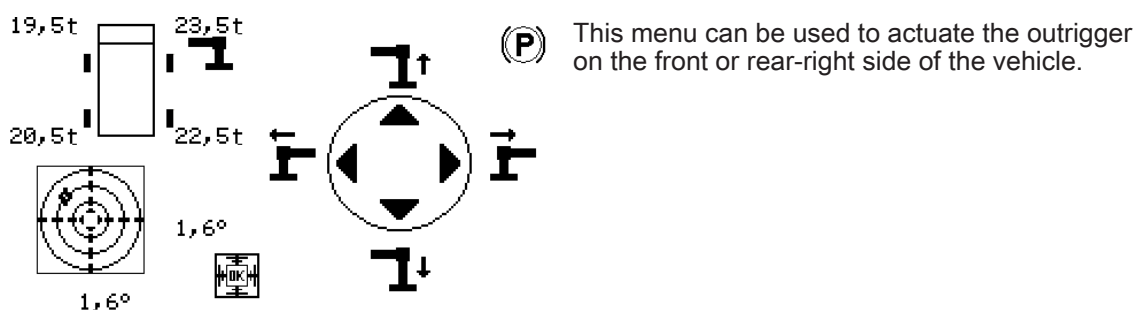

	Press the down arrow key and keep it pressed to extend the outrigger cylinders.
	Press the up arrow key and keep it pressed to retract the outrigger cylinders.
	Press the left arrow key and keep it pressed to extend the outrigger beam.
	Press the right arrow key and keep it pressed to retract the outrigger beam.
	Indicates the respectively selected outrigger.
	This shows the current outrigger pressure.
	The electronic circular spirit level shows the current vehicle inclination.
	Lights up when the mobile crane is leveled.
	Press the Quit key: back to the Outrigger menu.

All other keys are without any function.

#### Right outrigger control screen



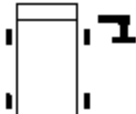
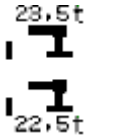
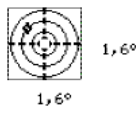



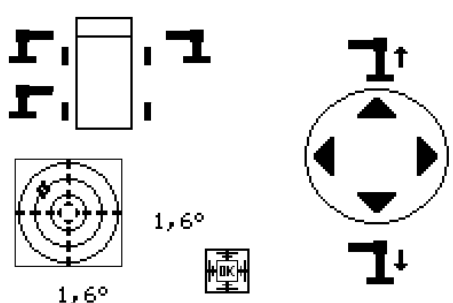

	Press the down arrow key and keep it pressed to extend the outrigger cylinders.
	Press the up arrow key and keep it pressed to retract the outrigger cylinders.
	Press the right arrow key and keep it pressed to extend the outrigger beam.
	Press the left arrow key and keep it pressed to retract the outrigger beam.
	Indicates the selected outrigger.
	This shows the current outrigger pressure.
	The electronic circular spirit level shows the current vehicle inclination.
	Lights up when the mobile crane is leveled.
	Press the Quit key: back to the Outrigger menu.

All other keys are without any function.

Screen - outrigger control when two or three outriggers are selected

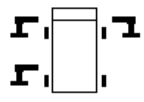
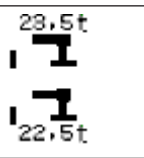
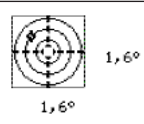
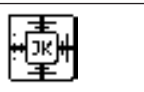

**(P)** This menu can be used to extend 2 or 3 outrigger cylinders.





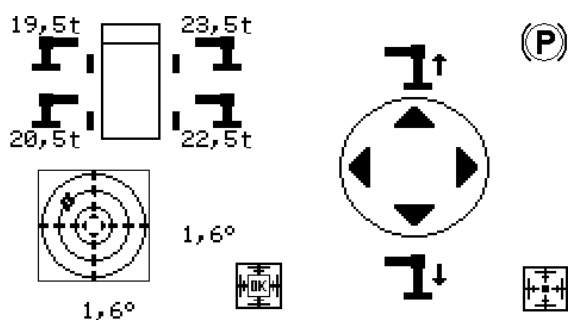

	Press the down arrow key and keep it pressed to extend the outrigger cylinders.
	Press the up arrow key and keep it pressed to retract the outrigger cylinders.
	Indicates the selected outriggers.
	This shows the current outrigger pressure.
	The electronic circular spirit level shows the current vehicle inclination.
	Lights up when the mobile crane is leveled.
	Press the Quit key: back to the Outrigger menu.

All other keys are without any function.

#### Screen - outrigger control when all four outriggers are selected

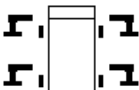
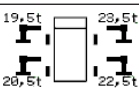
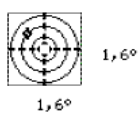

**(P)** This menu can be used to actuate all four outrigger cylinders.



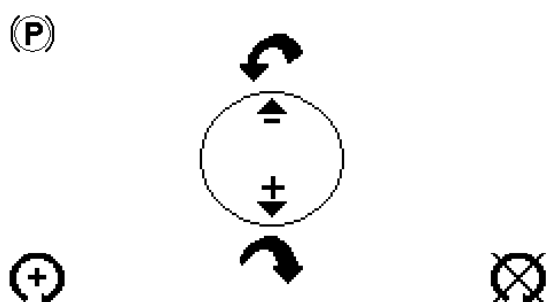

	Press the down arrow key and keep it pressed to extend the outrigger cylinders.
	Press the up arrow key and keep it pressed to retract the outrigger cylinders.
	Indicates the selected outriggers.
	This shows the current outrigger pressure.
	The electronic circular spirit level shows the current vehicle inclination.
	Lights up when the mobile crane is leveled.
	Press the F2 key and keep it pressed: the mobile crane will be brought to the leveled position. <b>NOTICE! All the outrigger cylinders must have ground contact and the wheels should not have any ground contact before automatic leveling.</b>
	Press the Quit key: back to the Outrigger menu.

All other keys are without any function.

### Carrier engine control menu





This menu can be used to start and stop the carrier engine as well as to increase or decrease the engine speed.

	Press the up arrow key to reduce the engine speed.
	Press the down arrow key to increase the engine speed.
	Press the F1 key: Start the carrier engine.
	Press the F2 key: Stop the carrier engine.
	Press the Quit key: back to the selection menu.

All other keys are without any function.

### 3.5 Automatic safe load indicator

	 <b>DANGER</b>
	<p><b>Accident risk!</b> Incorrect use of the automatic safe load indicator may cause an over-turn or damage of the machine, resulting in a serious accident.</p> <ol style="list-style-type: none"><li>1. Never operate the crane with the automatic stop function of the automatic safe load indicator deactivated.</li><li>2. Before commissioning the crane, check the functionality of the automatic safe load indicator.</li></ol>

The automatic safe load indicator calculates the working moment and rated moment based on the working state entered by the operator and input signal from each detector, and displays them as a moment ratio. When the moment ratio reaches 100 % or more, the automatic safe load indicator stops the crane operation toward the critical side and warns with corresponding warning messages and buzzer sounds.

The automatic safe load indicator is a safety device mounted to prevent accidents such as over-turning and damage of the mobile crane due to overload, and is not a load meter. The displayed lifting loads are reference values, and their accuracies are not guaranteed.

#### 3.5.1 Notes regarding the lifting capacity charts and supporting force tables

##### Lifting capacity chart

Lifting capacity charts are divided into different categories depending on the configuration of the mobile crane. Always select the lifting capacity chart that corresponds to the actual configuration. It contains all information essential for the crane operation. All information essential for the intended crane operation must be entered in the automatic safe load indicator before starting work. Further information in the "Notes regarding lifting capacity chart" must be followed.

##### Supporting force tables

In addition to the lifting capacity column, the supporting force tables contain the maximum supporting forces that act in the supported state when swiveling the loads specified in lifting capacity charts over 360°.

Likewise, the wheel loads acting when working on the wheels are listed "at the back" (if allowed, see the notes regarding the lifting capacity charts).

## 3.5.2 Control panel and displays

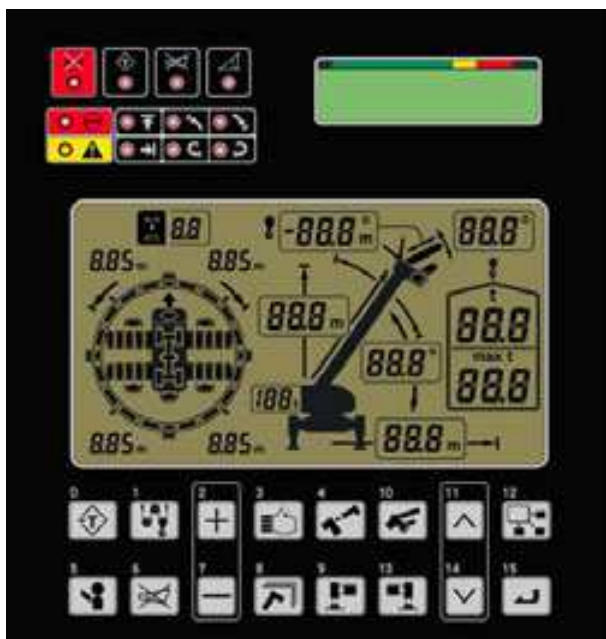



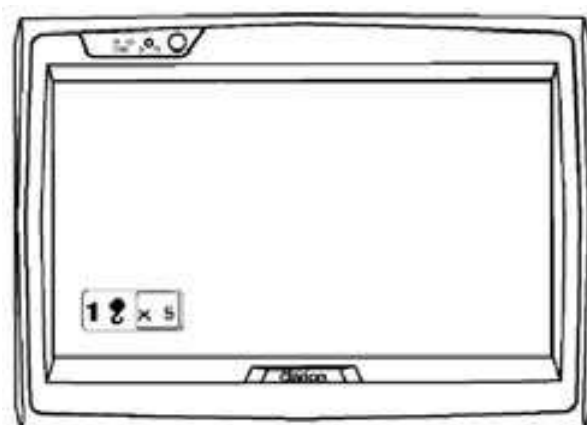





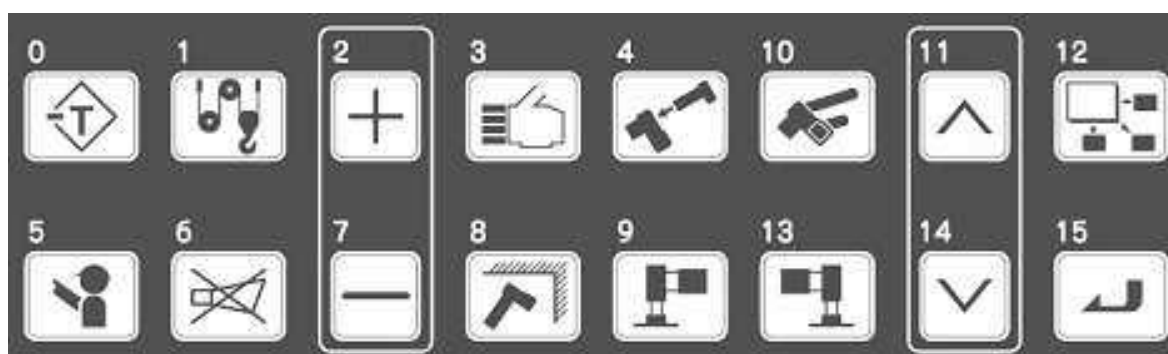







Control panel of the automatic safe load indicator with numeric and character displays



Graphical display

## Control Panel



No.	Icon	Function key	Description
0		<Tare>	You can use this key to activate or deactivate the "Tare" function. When you keep the key pressed, the Tare function will be activated and the displayed load value will be reset to zero. Naturally, the actual load values are also calculated for the automatic safe load indicator. If you press the key again, the Tare function will be deactivated.
1		<Rope falls>	You can use this key to select the number of rope falls.
2		<Plus>	You can use this key to increment a numeric value.
3		<Counterweight>	You can use this key to select the state of the counterweight.
4		<Setup mode>	You can use this key to select the setup mode of the automatic safe load indicator.
5		<Checking>	You can use this key to start the test function of the automatic safe load indicator or display the Special functions menu. When you keep this key pressed, the test function of the automatic safe load indicator will start. All LEDs and LCD segments will light up. Moreover, the alarm signal is sounded and the load moment of extending movements is blocked. You can deactivate the test function of the automatic safe load indicator by pressing the <Exit> key. If you keep the key pressed for longer than 3 seconds, the Special functions menu will appear. You can exit this menu by pressing the <Exit> key.
6		<Buzzer off>	You can use this key to deactivate the alarm signal temporarily.
7		<Minus>	You can use this key to decrement a numeric value.
8		<Working range limit>	You can use this key to call the "Working range limit" function.
9		<Left outrigger>	You can use this key to select the state of the left outrigger.
10		<Work mode>	You can use this key to toggle between the boom and luffing fly jib operation.
11		<Back>	You can use this key to select a menu. When you use this key for selecting a menu, the menu cursor jumps upwards or to the left.
12		<Exit>	You can use this key to end or deactivate the current state or the current function. When you press this key, the automatic safe load indicator changes to the original (basic) display mode.
13		<Right outrigger>	You can use this key to select the state of the right outrigger.
14		<Forward>	You can use this key to select a menu. When you use this key for selecting a menu, the menu cursor jumps downwards or to the right.
15		<Set>	You can use this key to set the selected state.

<b>i</b>	In the following descriptions, function keys are always indicated with "<...>".
----------	---

## Displays

### LEDs

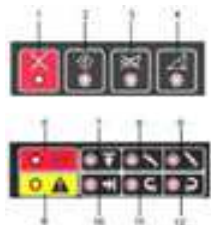

No.	LED	Description
1	"Automatic safe load indicator/anti-twoblock device override" LED	If you press the override key of the automatic safe load indicator or the anti-twoblock device, this LED lights up and indicates that the automatic stop function is deactivated.
2	"Tare" LED	This LED lights up when the "Tare" function is activated.
3	"Buzzer off" LED	This LED lights up when the "Buzzer off" function is activated.
4	"Angle-specific lifting capacity" LED	This LED lights up when the automatic safe load indicator is monitored using the angle-specific lifting capacity (only in case of luffing fly jib operation).
5	"Automatic stop" LED	This LED lights up in case of an operating state that leads to an automatic stop. It also lights up when the override key of the automatic safe load indicator or the anti-twoblock device is actuated.
6	"Pre-warning" LED	This LED lights up when the load condition reaches the pre-warning range (90–102.5%).
7	"Safety working range" (height) LED	These six LEDs indicate the current status of the safety working function:
8	"Safety working range" (upper angle limit) LED	<b>LED off</b> The Safety working range is deactivated.
9	"Safety working range" (lower angle limit) LED	<b>LED on</b> The safety working range is activated.
10	"Safety working range" (radius) LED	<b>LED flashes</b> The limit of the working range was reached; the movement will be stopped.
11	"Safety working range" (left slew) LED	
12	"Safety working range" (right slew) LED	

### LCD field

#### Numerical display

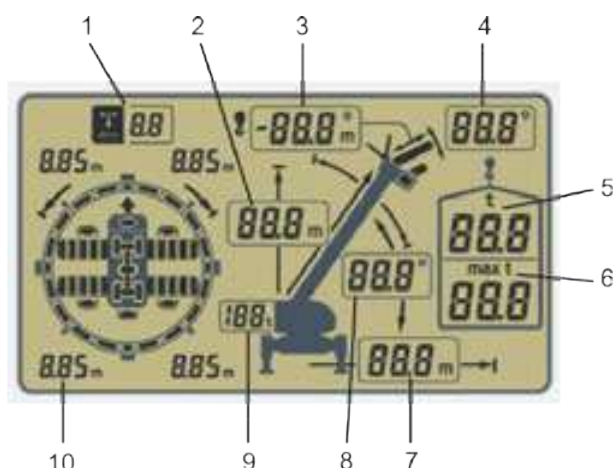

No.	Display	Description
1	Wind speed display	Indicates the wind speed.
2	Boom length display	Indicates the boom length in the normal mode. When the "Safety working range" function is activated or deactivated, the corresponding height limits are displayed.
3	Luffing fly jib length display	Indicates the luffing fly jib length (if the luffing fly jib mode is activated). If you press the <Rope falls> key, "Pxx" will be displayed ("xx" stands for the number of rope falls). The lifting height is shown when the "Lifting height" switch is activated. When the "Safety working range" function is activated or deactivated, the upper limiting value for the boom angle is displayed.
4	Luffing fly jib angle display	Indicates the offset angle of the luffing fly jib (if the luffing fly jib mode is activated).
5	Load display	Indicates the load in the normal mode. In most display modes (e.g. in the luffing fly jib mode), "- - -" is displayed here.
6	Rated load display	Indicates the rated load in the normal mode. In most display modes (e.g. in the luffing fly jib mode), "- - -" is displayed here.
7	Working radius display	Indicates the working radius in the normal mode. In most display modes (e.g. in the luffing fly jib mode), "- - -" is displayed here. When the "Safety working range" function is activated or deactivated, the limiting value for the working radius is displayed.
8	Boom angle display	Indicates the boom angle in the normal mode. When the "Safety working range" function is activated or deactivated, the lower limiting value for the boom angle is displayed.
9	Counterweight display	Indicates the selected counterweight.
10	Outrigger beam length display (1-4)	No function in case of ATF 130G-5.

<b>i</b>	Numeric units are changed depending on the displayed information.
----------	---





#### Segment symbols

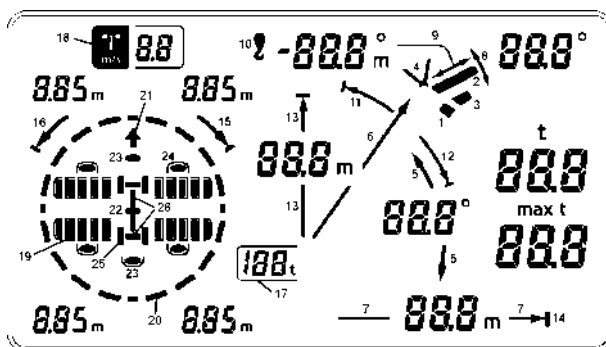

Classification Symbol	Seg. No.	Description
Boom/luffing fly jib	1	Boom symbol: This symbol appears when the boom mode is selected.
	2	Luffing fly jib symbol: This symbol appears when the luffing fly jib mode is selected.
	3	Single top symbol: This symbol appears when the single top mode is selected.
	4	No function in case of ATF 130G-5.
Display Symbol	5	Boom angle symbol: It indicates that the boom angle is displayed on the boom angle display.
	6	Boom length symbol: It indicates that the boom length is displayed on the boom length display.
	7	Working radius symbol: It indicates that the working radius is displayed on the working radius display.
	8	Luffing fly jib angle symbol: It indicates that the luffing fly jib angle is displayed on the luffing fly jib angle display.
	9	Luffing fly jib length: It indicates that the luffing fly jib length is displayed on the luffing fly jib length display.
	10	Hook symbol: This symbol appears when the number of rope falls or the lifting height is shown on the luffing fly jib length display.
	11	Upper limiting value for boom angle symbol: This symbol indicates that the upper limiting value of the boom angle is shown on the luffing fly jib length display.
	12	Lower limiting value for boom angle symbol: This symbol indicates that the lower limiting value of the boom angle is shown on the boom angle display.
	13	Boom height limit symbol: This symbol indicates that the boom height limit is shown on the boom height display.
	14	Limiting value of the working radius symbol: This symbol appears when the limiting value of the working radius is entered or deactivated.
	15	Right slew limit symbol: This symbol appears when the limiting range of the right slew limit is entered or deactivated.
	16	Left slew limit symbol: This symbol appears when the limiting range of the left slew limit is entered or deactivated.
	17	Counterweight symbol: This symbol appears when the selected counterweight is displayed.

	18	Wind speed symbol: This symbol appears when the wind speed is displayed.
Other symbols	19	Symbols for outrigger show the current outrigger state. Symbols with empty borders indicate the possible outrigger positions, whereas symbols with filled borders indicate the selected outrigger positions.
	20	Slew position symbol: It indicates the slew position with the help of 20 segments.
	21-24	No function in case of ATF 130G-5.
	25-26	"On-wheels" symbols indicate that the "Vehicle on-wheels" mode has been selected.

### Character display

The character display has two rows of 16 characters each. A bar chart is normally displayed in the first row for showing the load condition, and the lifting height or the pump pressure is displayed in the second row. You can use the keys <Back> or <Forward> to change the display. The corresponding error code is displayed if an error occurs.

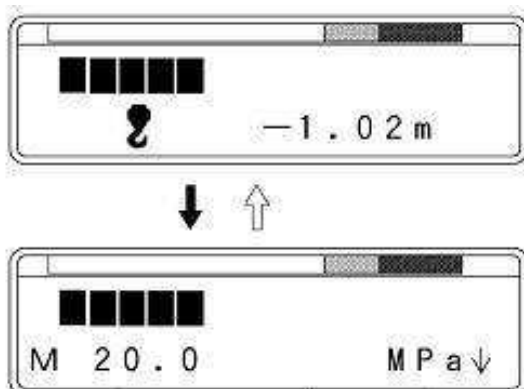

A warning message (e.g. Anti-twoblock device initiated, Overload, etc.) appears in the second row. Warning messages are preceded with a "W".

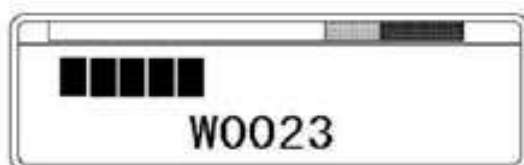

If a system error occurs, the error message is shown in the first row. Error messages are preceded with an "E".

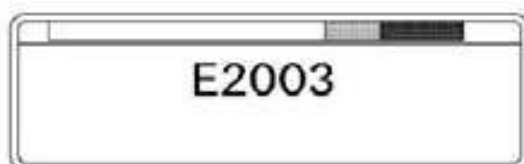

For the description of different codes for warning and error messages, please refer to section Warning and error codes.

### Contrast setting for the character display

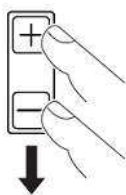

1. Keep the <Plus> and <Minus> keys pressed at the same time for at least 3 seconds.  
⇒ "Set Contrast" will be shown in the second row of the character display, and the display will switch to the mode for setting contrast.

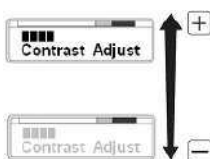

2. Set the contrast using the <Plus> and <Minus> keys.  
Press the <Plus> key to increase contrast or the <Minus> key to decrease contrast.
3. Press the <Set> key.  
⇒ The current contrast is registered, and the previous crane operation state is restored.

If no operation is performed within 5 seconds, or the <Exit> key is pressed, the display returns to the previous crane operation state without registering the displayed contents.

Stored information is retained even if the automatic safe load indicator is deactivated. When the automatic safe load indicator is activated, the operation starts with the retained registered information.

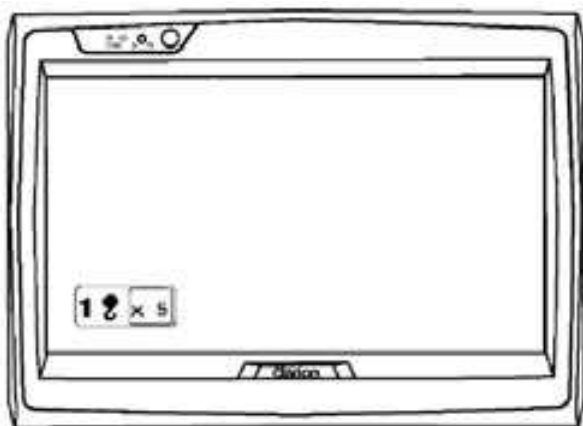

### Graphical display



The graphical display shows the number of falls. If a 2nd hoisting gear is installed, information regarding it is also shown on the graphical display.

The graphical display is also used for telescoping and for special functions.

### 3.5.3 Entering the operating conditions

	 <b>DANGER</b>
	<p><b>Incorrect or incomplete entries of operating conditions in the automatic safe load indicator!</b></p> <p>Incorrect or incomplete entries of operating conditions in the automatic safe load indicator can lead to accidents. The mobile crane can reach an unstable area and tilt. This could be fatal.</p> <ol style="list-style-type: none"> <li>1. Enter the operating conditions have been correctly and completely on the basis of the lifting capacity chart,</li> <li>2. Check the operating conditions before the crane operation.</li> </ol>

Basic functions of the automatic safe load indicator are:

- Calculating the load conditions in the crane operation,
- Transferring the information to the crane driver and
- Stopping the crane movement as soon as an overload is detected.



Before starting the crane operation, the corresponding operating state must be saved correctly in the automatic safe load indicator.

In this system, the crane driver must enter the following operating conditions:

- State of the right and left outriggers,
- State of the counterweight,
- State of the boom or the luffing fly jib and
- Number of rope falls.

	<p>Operating conditions can be entered only if the boom is retracted completely.</p>
---	--



### Entering the outrigger conditions

In the normal state of the ASLI display, press <Right outrigger>  or <Left outrigger>  to switch to the mode for entering the outrigger state.

The display of the LCD field changes as follows:



1	Outrigger state indicator Detected state is indicated by flashing.	3	Actual load display: "- - -" flashes.
2	Rated load display: "- - -" flashes.		

-  Maximum (7.50 m)
-  Minimum (5.00 m)

**Procedure if the detectors for the outrigger length are not installed**

After pressing the <Right outrigger> key, the right side of symbols for the operating state of outriggers starts flashing. If you further press <Right outrigger>, <Back> or <Forward>, the operating state of the right outriggers will be set to the next outrigger length. Press <Set> to enter the currently selected state of the outrigger.

After pressing the <Left outrigger> key, the left side of symbols for the operating state of outriggers starts flashing. If you further press on <Left outrigger>, <Back> or <Forward>, the operating state of the left outriggers will be set to the next outrigger length. Press <Set> to enter the currently selected state of the outrigger.

Press on <Exit>  to exit the mode for entering the state of outriggers.

**Procedure if the detectors for the outrigger length are installed**

If you press the <Right outrigger> or <Left outrigger> key, all symbols for the operating state of outriggers start flashing depending on the state recorded by the detectors.

Ensure that the display corresponds to the actual states of outriggers and then press <Set> to save these states.

Symbols for the operating state of outriggers stop flashing and light up constantly, whereas all displays return to the normal state. This means that the state of outriggers has been saved.

Press on <Exit>  to exit the mode for entering the state of outriggers without saving. If the ASLI detects that an outrigger has been extended by a shorter distance, its actual state is indicated through flashing. In such a case, you must save the state of the outrigger again.

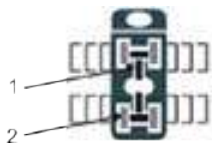

1 = lights up; 2 = flashes

The state of outriggers is automatically changed to "On-Wheels" ("Vehicle on-wheels" mode) if measures for retracting the outrigger completely were taken after saving. Ensure that you save the state of outriggers again if required.

### Entering the counterweight state

In the normal state of the ASLI display, press <Counterweight>  to switch to the mode for entering the counterweight state.

The display of the LCD field changes as follows:



1	Counterweight value display flashes.	3	Actual load display: "- - -" flashes.
2	Rated load display: "- - -" flashes.		

When you press the <Counterweight> key, the counterweight value display (1) starts flashing and shows the value stored earlier. Moreover, the displayed values for the actual load (3) and the rated load (2) also start flashing and "- - -" is shown.

With every further click on <Counterweight>, the counterweight state value goes to the next state.

Press <Set> to enter the currently selected state of the counterweight.

Press on <Exit> to exit the ASLI mode for entering the counterweight state.

Entering the state of the boom or the luffing fly jib

Selecting the state of the boom or the luffing fly jib

In the normal state of the ASLI display, press <Work mode>  to switch to the mode for entering the state of the boom or the luffing fly jib.

The display of the LCD field changes as follows:



1	Boom symbol flashes	3	Actual load display: "- - -" flashes.
2	Rated load display: "- - -" flashes.		

Boom flashes



Single top flashes



Luffing fly jib flashes



When you press the <Work mode> key, the boom or luffing fly jib state display starts flashing and shows the value stored earlier. Moreover, the displayed values for the actual load and the rated load also start flashing and "- - -" is shown.



With every further click on <Boom>, <Back> or <Forward>, the boom/luffing fly jib symbol goes to the next state.

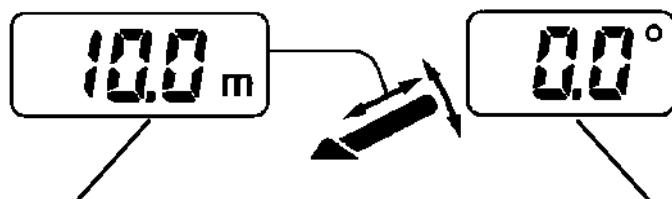

#### Luffing fly jib length display:

As long as the luffing fly jib symbol is visible, the length of the luffing fly jib is displayed.

#### Luffing fly jib angle display:

As long as the luffing fly jib symbol is visible, the offset angle of the luffing fly jib is displayed.

The following steps of luffing fly jib configuration are shown in the input mode of the luffing fly jib: The first configuration of the luffing fly jib length and the corresponding offset angle (e.g. 10.0 m (32.8 ft), 0.0°) are shown first. After you press <Work mode> (or <Forward>), the next configuration of the offset angle (e.g. 10.0 m (32.8 ft), 20.0°) is displayed. After displaying all existing configurations of the offset angle, the next configuration of the luffing fly jib length and the corresponding first offset angle (e.g. 18.0 m (59.1 ft), 0.0°) are displayed. In case of a hydraulic telescope and luffing fly jib\*), the configuration of the luffing fly jib length is displayed along with the current luffing fly jib angle (e.g. 10.0 m (32.8 ft), 5.4°).

Press <Set> to enter the currently selected state of the boom/luffing fly jib.

Press on <Exit> to exit the ASLI mode for entering the boom or luffing fly jib state.

In case of a system with only one telescope cylinder, the crane driver must select the telescope state after entering the boom and/or luffing fly jib state. Select the *Telescope State* [page 112].

Examples of luffing fly jib configurations

Example of hydraulic telescope and luffing fly jibs\*)



### Setup mode

The setup mode is a special mode for mounting the jib on the boom. This mode also has the following function:

- Deactivating the anti-twoblock device

In the normal state of the ASLI display, press <Setup mode>  to switch to the setup mode.

The display of the LCD field changes as follows:

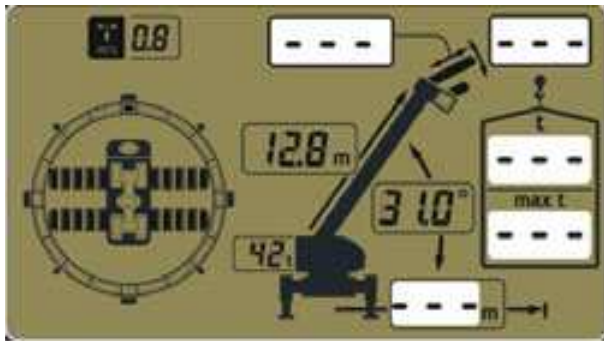

The load bar in the character display disappears. Instead of this, the pressure in the hydraulic system or the lifting height (depending on the switch position for the lifting height beyond the automatic safe load indicator) as well as possible error or warning messages are displayed.

The luffing fly jib symbol starts flashing after pressing the <Setup mode> key. Moreover, the displayed values for the actual load, the rated load, the working radius, the luffing fly jib length and the luffing fly jib angle also start flashing and " - - - " is shown.

If you now press the <Set> key, the setup mode will be activated (if you press <Exit>, the automatic safe load indicator exits the setup mode). The display of the LCD field changes as follows:

- Luffing fly jib symbol display: continuously active.
- Luffing fly jib length display: " - - - " flashes.
- Luffing fly jib angle display: " - - - " flashes.
- Load display: " - - - " continuously active.
- Rated load display: " - - - " continuously active.
- Working radius display: " - - - " continuously active.

If you also activate the telescope state indicator box, the graphical display changes as follows: In the setup mode, it is not possible to move the telescope in the automatic mode. If required, a movement is possible only in the manual mode.

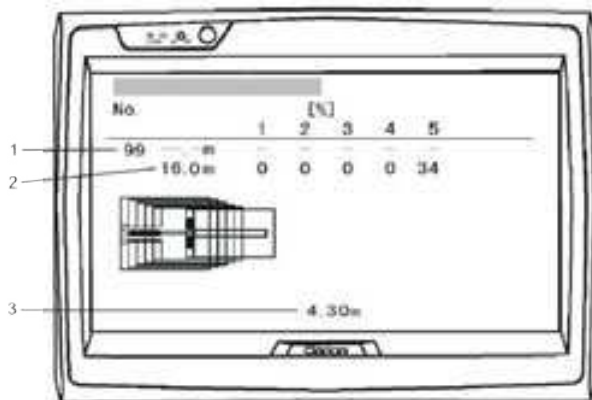

1	Boom target number (constant 99)	3	Current length of the telescope cylinder
2	Current boom position		



1	Boom target number (constant 99)
2	Current length of the telescope cylinder

The jib can now be mounted.

After mounting, press the <Work mode> key several times to select the desired luffing fly jib configuration. After selecting the configuration, press the <Set> key for input.

## Display of rope falls and lifting heights

### Entering the rope falls

In the normal state of the ASLI display, press <Rope falls>  to switch to the mode for entering the rope falls.

The hook symbol appears in the LCD field and the default or pre-specified number of rope falls appears on the display of the luffing fly jib length.

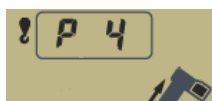

The luffing fly jib length display is used for entering the rope falls.

The letter "P" indicates that the displayed value corresponds to the number of rope falls.

The number of rope falls can be changed using the <Plus> and <Minus> keys.

After pressing the <Set> or <Exit> keys, you can enter the number of rope falls in the ASLI.

**NOTICE! The entered number of rope falls is used for protecting the rope from breaking by limiting the maximum load. The number of rope falls must be entered correctly when the lifting height function is used. The number of falls is stored even after deactivating the automatic safe load indicator.**

### Lifting height display

If the switch for the lifting height is activated from the main or auxiliary winch (the switch is outside the automatic safe load indicator), the automatic safe load indicator indicates the lifting height of its neutral position.

When operating the boom or the single top, the lifting height is shown on the luffing fly jib length display.

When operating or when setting the luffing fly jib, the lifting height is shown on the character display.

### Resetting the lifting height

If the switch is used for resetting the lifting height (integrated into the switch for the lifting height of the main winch outside the automatic safe load indicator), the automatic safe load indicator resets the value for the lifting height. After resetting the value, the automatic safe load indicator shows the hook position (height) with respect to the initial point. A positive value indicates an upward move of the hook, whereas a negative value indicates a downward movement.



Luffing fly jib length display for showing the lifting height. The hook symbol indicates that the displayed value corresponds to the lifting height.

#### 3.5.4 Operating the telescopic boom

This chapter explains the operation the LCD graphical display of the telescopic boom.

##### Selecting and controlling the telescopic boom

The following instructions must be observed when selecting the telescopic boom mode (target position of boom) and for controlling its functions:



1. Press the On/Off switch of the telescope state indicator box.  
 ⇒ The selection table for the telescopic boom will then appear on the LCD graphical screen.

No.	1	2	3	4	5
1	12.8m	0	0	0	0
2	17.1m	0	0	0	46
3	21.4m	0	0	0	92
4	25.8m	0	0	46	92
5	30.1m	0	0	92	92
6	34.4m	0	46	92	92
7	38.7m	0	92	92	92
8	43.0m	0	46	92	92
9	47.4m	0	92	92	92
10	51.7m	46	92	92	92
11	56.0m	92	92	92	92

1	A marking will appear at the currently saved target position of the boom.	3	Instructions or error messages are shown in this area.
2	Box-shaped cursor for selecting the boom position. Move the cursor using <Forward> or <Back>. As soon as the cursor reaches the lower end, the next menu page will be displayed. Use <Plus> or <Minus> to browse through menu pages.	4	The target position of the boom is shown for every boom part.

1. Press <Forward> or <Back> to move the cursor up or down to the desired target position of the boom. Use <Plus> or <Minus> to browse through table pages.  
 ⇒ When the selection table for the telescopic boom is shown on the graphical screen, the boom selection table is also shown on the character display.

A marking will appear at the currently saved boom position.

- \*1 12.8 m ↓
- 2 17.1 m ↓
- 3 21.4 m ↓

Only two rows are shown.

You can use the <Forward> and <Back> keys to scroll through the displayed positions in order to select another position.

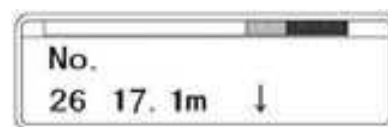

- ...
- 28 17.1 m ↓
- 29 21.4 m ↓
- ...

1. After selecting, press <Set>. The selected boom target will then be saved and the graphics for the boom control will appear on the graphical screen.

If you actuate the telescope control lever before pressing the <Set> key, the graphics for the boom control will appear. Press <Exit> to display the telescopic boom selection table.

Example:

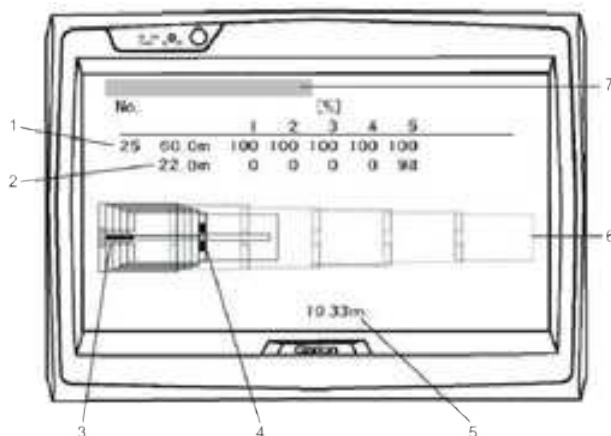

1	Target position of the boom	5	Length of the telescope cylinder
2	Current boom position	6	Target position of the boom (graphical)
3	Graphical status display of the boom lock (B-pin): <ul style="list-style-type: none"> <li>● Green: locked</li> <li>○ Non-filled circle: unlocked</li> <li>● Red: Sensor error</li> <li>● Yellow: locking or unlocking process is running</li> </ul>	7	Instructions or error messages are displayed here: <ul style="list-style-type: none"> <li>⇒ ⇒ ⇒ ⇒ Note: extend</li> <li>⇐ ⇐ ⇐ ⇐ Note: retract</li> </ul>
4	Graphical status display of the cylinder lock (C-pin): <ul style="list-style-type: none"> <li>■ Oblong green rectangle: locked</li> <li>□ Non-filled rectangle: unlocked</li> <li>■ Red: Sensor error</li> <li>■ Yellow: locking or unlocking process is running</li> </ul>		

1. When the graphics for the boom control is shown, operate the control lever as per the instructions on the graphical display.
2. Press the On/off switch of the telescope state indicator box as soon as the telescoping operation is complete. The graphics for the boom control will then be deactivated. If you do not press the On/off switch of the telescope state indicator box, graphics for the boom control will remain active.

When the boom state graphics is shown on the LCD graphical display, the boom length is also shown on the character display.

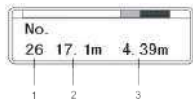

1	Number of the telescope target	3	Current length of the telescope cylinder
2	Length of the telescope target		

## Telescope selection for the main boom

Boom target						
No.	Length [m (ft)]	Tele.1 [%]	Tele.2 [%]	Tele.3 [%]	Tele.4 [%]	Tele.5 [%]
1	12.8 (42.0)	0	0	0	0	0
2	17.1 (56.1)	0	0	0	0	46
3	21.4 (70.2)	0	0	0	0	92
4	25.8 (84.7)	0	0	0	46	92
5	30.1 (98.8)	0	0	0	92	92
6	34.4 (112.9)	0	0	46	92	92
7	38.7 (127.0)	0	0	92	92	92
8	43.0 (141.1)	0	46	92	92	92
9	47.4 (155.5)	0	92	92	92	92
10	51.7 (169.6)	46	92	92	92	92
11	56.0 (183.7)	92	92	92	92	92
12	21.4 (70.2)	0	0	0	46	46
13	25.8 (84.7)	0	0	46	46	46
14	30.1 (98.8)	0	46	46	46	46
15	34.4 (112.9)	46	46	46	46	46
16	38.7 (127.0)	92	46	46	46	46
17	34.4 (112.9)	0	46	46	46	92
18	38.7 (127.0)	46	46	46	46	92
19	43.0 (141.1)	92	46	46	46	92
20	43.0 (141.1)	46	46	46	92	92
21	43.0 (141.1)	92	92	46	46	46
22	47.4 (155.5)	92	92	92	46	46
23	47.4 (155.5)	46	92	92	92	46
24	51.7 (169.7)	92	92	92	92	46
25	60.0 (196.9)	100	100	100	100	100
26	17.1 (56.1)	0	46	0	0	0
27	21.4 (70.2)	46	46	0	0	0
28	17.1 (56.1)	0	0	46	0	0
29	21.4 (70.2)	0	46	46	0	0
30	25.8 (84.7)	46	46	46	0	0
31	30.1 (98.8)	92	46	46	0	0
32	25.8 (84.7)	0	46	46	46	0
33	30.1 (98.8)	46	46	46	46	0
34	34.4 (112.9)	92	46	46	46	0

#### Telescope selection table for the luffing fly jib mode

Boom target						
No.	Length [m (ft)]	Tele.1 [%]	Tele.2 [%]	Tele.3 [%]	Tele.4 [%]	Tele.5 [%]
1	12.8 (42.0)	0	0	0	0	0
11	56.0 (183.7)	92	92	92	92	92
15	34.4 (112.9)	46	46	46	46	46
21	43.0 (141.1)	92	92	46	46	46
25	60.0 (196.9)	100	100	100	100	100
30	25.8 (84.7)	46	46	46	0	0

#### Operating the telescopic boom in the manual mode

The manual mode for operating the telescopic boom can be activated using a switch on the instrument panel which is separate from the ASLI.

For further instructions regarding the operation of the telescopic boom in the manual mode, please refer to the operating manual of the superstructure.

The graphics for the boom control is also shown when operating the telescopic boom in the manual mode.

<b>i</b>	When operating the telescopic boom in the manual mode, the display may often vary from the normal graphics for the boom control.
----------	--

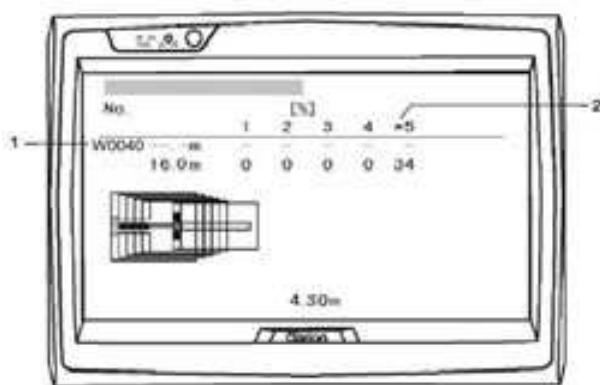

1 The "E02" indicates the manual mode	2 * indicates the cylinder position
---------------------------------------	-------------------------------------

<b>i</b>	When operating the telescopic boom in the manual mode, press the B and C-pins only when the "*" symbol is displayed.
----------	--



### 3.5.5 Safety working range

If the working range in the automatic safe load indicator is restricted and if the crane reaches the limiting range, the automatic safe load indicator stops the crane automatically.

The following working ranges can be restricted in the automatic safe load indicator:

- Boom height
- Upper limit of the boom angle
- Lower limit of the boom angle
- Working radius
- Left slew
- Right slew

<b>i</b>	<p>When the "Automatic safe load indicator override" key-operated switch is activated, the safety working range is deactivated.</p> <p>When the Slow-Stop function is deactivated (switch on the instrument panel outside the automatic safe load indicator), the slew range limit is deactivated.</p> <p>When the slewing gear brake is not applied, the slewing movement sometimes does not stop immediately (owing to the flywheel of the superstructure).</p> <p>The stored values for the safety working range are retained even after deactivating the automatic safe load indicator.</p>
----------	---

### Selection, saving and deactivation

In the normal state of the ASLI display, press <Safety working range> to switch to the mode for entering the safety working range.

When you press the keys <Safety working range> or <Forward>, the selectable limits in the automatic safe load indicator will change cyclically in the sequence described below. If you press <Back>, they will be selected in the reverse order.

Boom height → upper boom angle → lower boom angle → working radius → left slew → right slew → boom height → ....

When selecting the limit, the currently selected limit flashes on the numerical display, whereas other (non-selected limits) light up constantly. When you press the <Set> key, the current crane position will be entered as the desired limiting value in the ASLI and the mode for the safety working range will be exited. When you press <Set> again in the mode for entering the limit, the active limiting value will be deleted.

Press on <Exit> to exit the ASLI mode for entering the safety working range.

### Displayed information

#### Numerical display

The following table shows the positions of the limit information with reference to the normal display information.

Normal information	Information regarding limits
Boom length	Limit of the boom height
Luffing fly jib length	Upper limit of the boom angle
Boom angle	Lower limit of the boom angle
Working radius	Working radius limit

The following table shows the state of the safety working range as per the selection/save status.

Selection/save status	Display state
not selected (not saved)	"- - -" will be displayed
not selected (already saved)	Display of the entered value
selected (not saved)	Current value is indicated by flashing
selected (already saved)	Display of the entered value

#### Display of the slew angle limit

Limiting values of the slew angle cannot be shown on a numerical display. For this purpose, segment symbols in the LCD field need to be used. The status of the slew limit can be determined from the corresponding LEDs.

#### Display examples

Example 1: LCD field with selected height limit

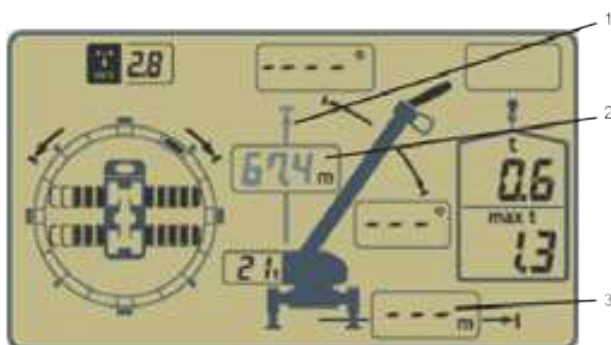

Height limit - value not yet saved

1	The boom height limit symbol flashes → the boom height limit is selected.	3	Other sections of the numerical display show "- -" → no other options are selected and saved.
2	The boom height display flashes and shows the current boom height → the value is not saved.		

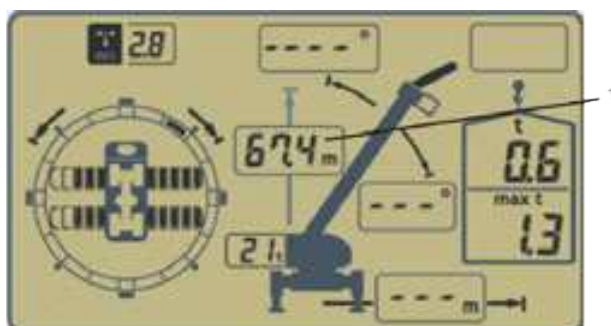

Height limit – value saved

1	The boom length displays shows the saved boom height → the saved value can be deleted by pressing the <Set> key.		
---	--	--	--

Example 2: LCD field with selected upper limit of the boom angle

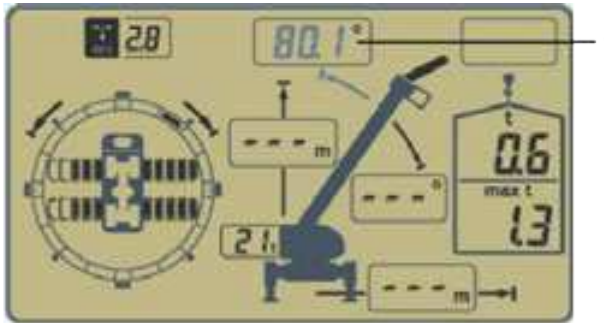

Upper limit of the boom angle

1	The value for the upper limit of the boom angle is shown on the luffing fly jib display. If the limit function is not saved, the current boom angle flashes.	
---	---	--

Example 3: LCD display for the slew angle limit

When the limit of the left slew angle is selected, the ASLI identifies the range of 90° (degrees) to the left of the current slew position as the limited range. All symbols for slew positions in this range flash. The limit of the right slew angle is not yet saved.

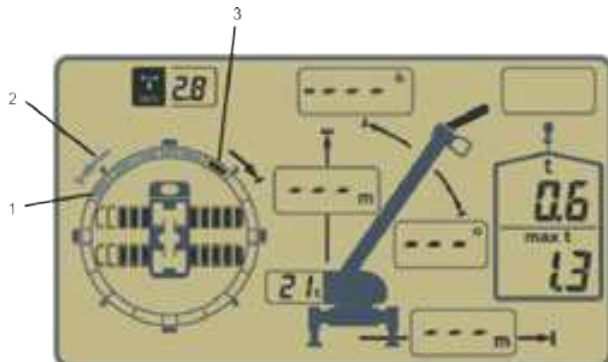

Slew limit – left limiting value selected, right limiting value not yet saved

1	The right slew limit is not yet saved → the ASLI identifies the range of 90° to the left of the current slew position as the limited range. Symbols for the slew position flash.	3
2	The left slew limit symbol flashes → the Left slew limit function is selected.	

The left slew limit is saved, whereas the right slew limit is not yet selected or saved.

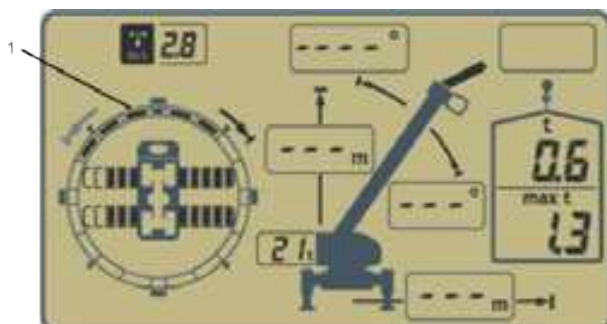

*Slew limit – left limiting value selected, right limiting value not selected or saved*

1	<p>If only the left slew limit is saved and if the crane with a left slew reaches this range, the ASLI stops the crane automatically.</p> <p>On the other hand, if the crane reaches this range with a right slew, the ASLI does not stop the crane.</p>	
---	--	--

The left slew limit is already saved, whereas the right slew limit is selected or but not saved.

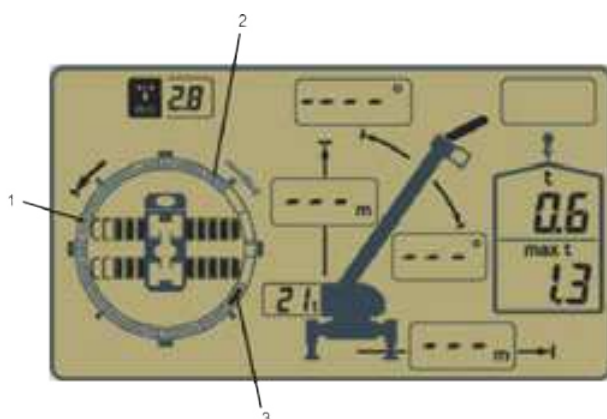

*Slew limit – left limiting value saved, right limiting value selected, but not saved*

1	<p>The slew range between the actual position and the saved left slew limit is identified as the limiting range.</p>	3	<p>Current slew position selected as the right limit</p>
2	<p>Left slew limit has already been saved</p>		

### Summary of display information

#### Function keys:

<p>&lt;Safety working range&gt;</p> <p>&lt;Forward&gt;</p> <p>&lt;Back&gt;</p> <p>&lt;Set&gt;</p> <p>&lt;Exit&gt;</p>	<p>Activates the safety working range mode. Changes the selectable limits.</p> <p>Changes the selectable limits.</p> <p>Changes the selectable limits.</p> <p>Saves or deletes the limiting value for the working range. Exits the safety working range mode.</p> <p>Exits the safety working range mode.</p>
---	---

### Limit symbols:

Flashing	A limit is selected.
Active continuously	A limit is not selected.

### LEDs

Stop	The safety working range is not active.
Active continuously	The safety working range is active.
Flashing	The safety working range and the automatic stop function are active.

### Numerical display

The value is displayed continuously	The safety working range is saved.
Flashing value	The safety working range is selected, but not saved. The current position value flashes.
'- - -'	The safety working range is neither selected nor saved.

	The stored values for the safety working range are retained even after deactivating the automatic safe load indicator.
---	--

### 3.5.6 Test function

When you press the <Test>  key, the automatic safe load indicator switches to the test mode. The following displays can be checked.





LCD field	All LCD segments are activated.
Character display	All segments are activated.
LEDs	All LEDs are activated.
Buzzer	The alarm sounds.
Crane operation	Winch up, derrick down, extend the telescope and lower the hydraulic telescope and luffing fly jib *) are deactivated.

When you press the <Exit>  key, the automatic safe load indicator returns to the normal mode.

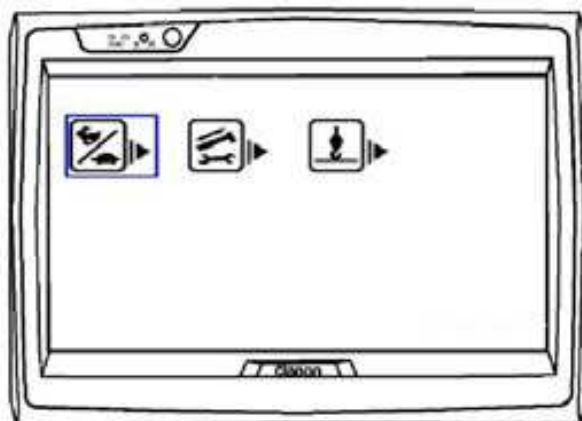
### 3.5.7 Special functions

If you press the <Test> key longer than three seconds, the symbols for some special functions will be displayed on the graphical display.



-  Speed pre-selection
-  Telescope maintenance function
-  Setting the lifting height
-  Exiting the "Slow telescoping" mode (under special conditions)

You can move the cursor using the keys <Forward> or <Back> to select a symbol and call the menu with <Set>.

You can use the <Exit> key to exit the menu.

### Speed pre-selection

Maximum speeds can be set for the following movements:

- Swing mechanism (right/left can be set separately)
- Derrick (lifting/lowering can be set separately)
- Hoisting gear (lifting/lowering can be set separately)
- 2. Hoisting gear (lifting/lowering can be set separately)

Select the "Speed pre-selection" symbol and call the menu by pressing the <Set> key.

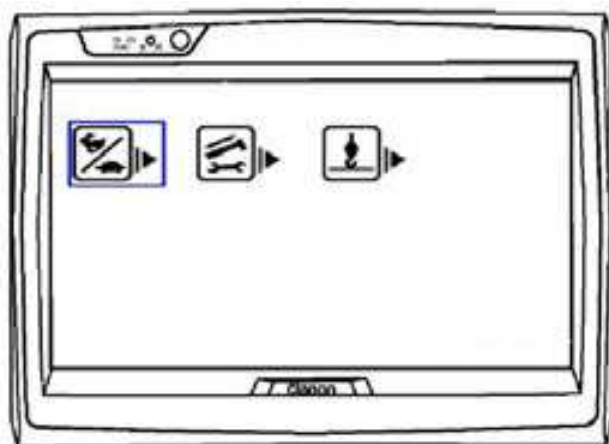

Select the speed pre-selection



When you select the "Speed pre-selection" menu, the symbols for the adjustable movements will be shown on the graphical display. You can select the desired icon using the suitable cursor movements (<Forward> or <Back>). The cursor must be positioned on the corresponding icon in order to change the speed pre-selection.

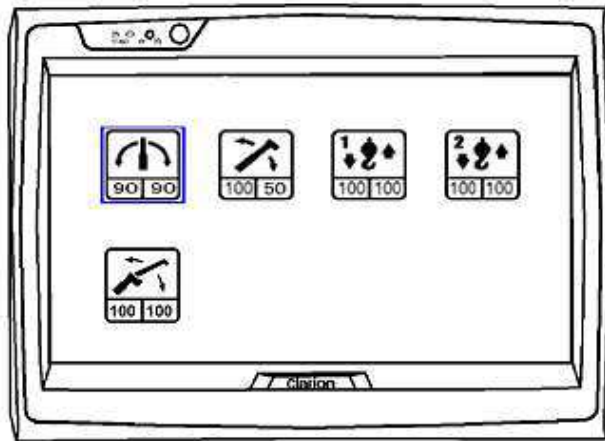

Pre-selection of the swing mechanism speed



Pre-selection of the derrick speed of the boom



Pre-selection of the speed of the 1st hoisting gear



Pre-selection of the speed of the 2nd hoisting gear



Pre-selection for the derrick speed for the luffing fly jib\*)



When you position the cursor on the desired symbol and press <Plus> or <Minus>, both directions are changed simultaneously.

If the speed needs to be changed only for one direction, you must simultaneously move the joystick for the corresponding movement. If you press the keys <Plus> or <Minus> during a right slew, only the speed for the right slew is affected. Likewise, if you press the keys <Plus> or <Minus> during a left slew, only the speed for the left slew is affected. Other movements function in the similar manner.

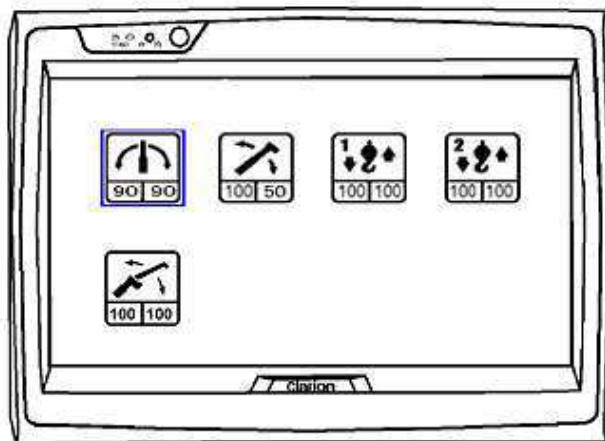

Select a symbol (move the cursor)



Select a symbol (move the cursor)



Increase the speed pre-selection value



Reduce the speed pre-selection value



Save the speed pre-selection value



Back to the normal mode



When you press the <Set> key, the set speed will be saved.

Press the <Exit> key to exit the speed pre-selection.

### Telescope maintenance function

Select the telescope maintenance function if you want to check or lubricate the boom.



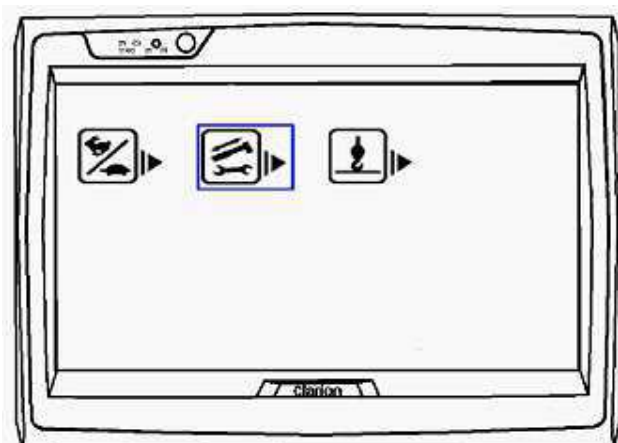

Select the maintenance function



When you select the "Maintenance" symbol, a special selection table for the telescopic boom will appear on the graphical display.

<b>i</b>	All boom states available here are solely intended for the maintenance purposes and not for lifting a load.
----------	---

#### Selection table for the telescope maintenance

Boom target						
No.	Length [m]	Tele.1 [%]	Tele.2 [%]	Tele.3 [%]	Tele.4 [%]	Tele.5 [%]
00	12.8	0	0	0	0	0
01	22,2	0	0	0	0	100
02	31.7	0	100	0	0	100
03	22.2	0	0	0	100	0
04	31.6	0	0	100	100	0
05	17.1	46	0	0	0	0
06	22.3	100	0	0	0	0
07	22.2	0	0	100	0	0
08	22.3	0	100	0	0	0

The procedure for the telescope maintenance is identical to the normal mode for telescoping the boom to a great extent. Only some displays differ from those in the normal mode.

**Graphical display:** A preceding "M" is shown before the target position number of the boom in the graphics for the boom control.

**LCD field:** Displays for the actual and rated loads show "--" since this mode is intended only for maintenance. Select the normal mode for displaying the actual and rated loads.

Press the On/off switch of the telescope state indicator box (outside the automatic safe load indicator) to exit the telescope maintenance function.

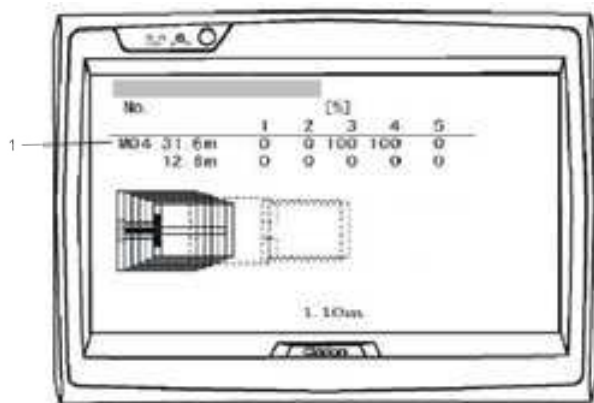

1 The "M" indicates the telescope maintenance function.

### Setting the lifting height

This setting needs to be configured when the value for the lifting height is not precise.

Procedure:

1. Select the hoisting gear to be set (2nd hoisting gear is the optional equipment) and enter the correct *number of rope falls* [page 111].
2. Select the actual *boom or luffing fly jib status* [page 108].
3. Lower the hook until it touches the ground lightly. Boom angle and boom length can be selected freely.
4. Select the "Setting of lifting height" symbol.

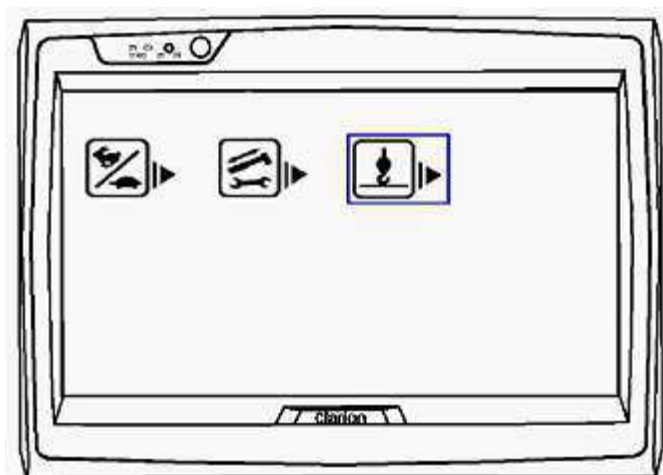

Setting the lifting height



The following display will appear:

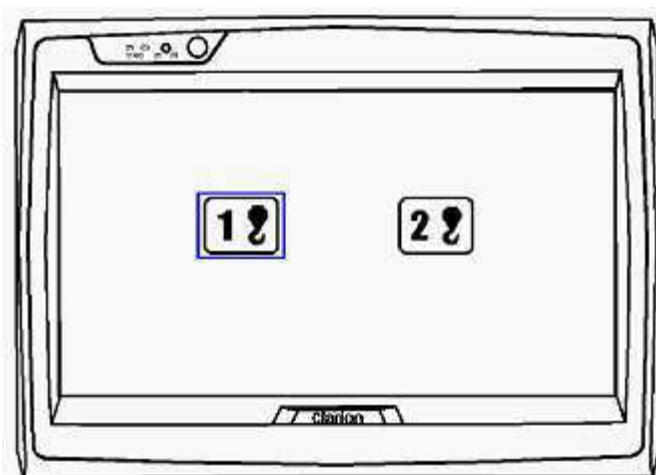

Set and exit the menu



Set and exit the menu



1. As soon as you press the <Set> key or the switch for resetting the lifting height (integrated into the switch for the lifting height of the hoisting gear outside the automatic safe load indicator), the setting is saved and the symbols for special functions are shown on the graphical display.
2. Press <Exit> to exit the menu for special functions.

### Deactivating the slow telescope mode

Slow telescope mode:

The speed of movements of B- and C-pins are continuously monitored by the ASLI system. If the movement of the B or C-pin becomes too slow, a tortoise symbol will appear on the graphical display. In such a case, the telescope speed of the ASLI is automatically reduced.

The tortoise symbol normally appears only when the ambient temperature drops below -10 °C.

However, the symbol may appear when telescoping long time after the boom was extended.

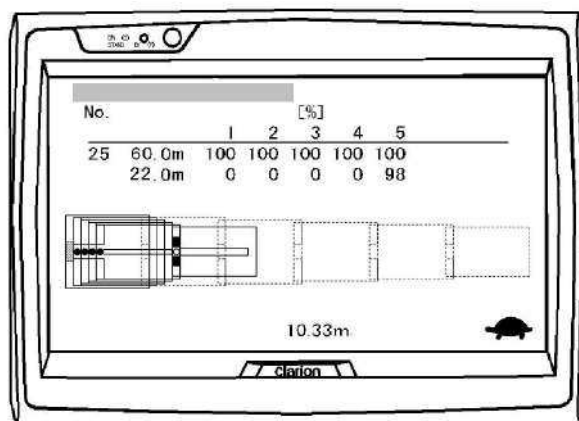

If the tortoise symbol appears at temperatures above 0 °C, the Slow telescope mode can be deactivated.

In the Slow telescope mode, an "Exit" symbol is added to the special functions menu.

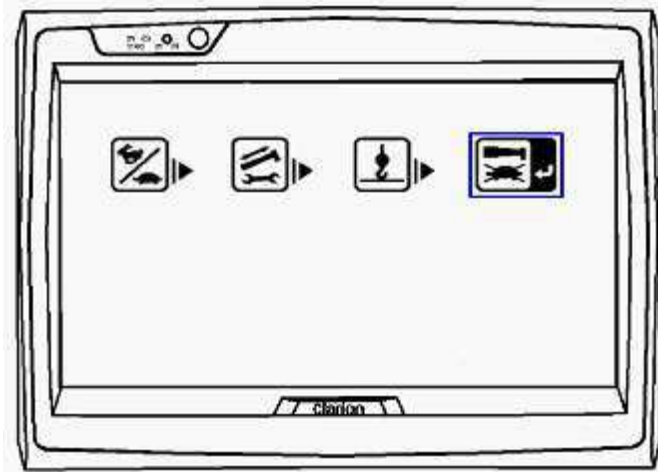

Deactivating the slow telescope mode



For deactivating the Slow telescope mode, select the corresponding symbol using the cursor and press <Set>. The special functions mode will then be exited and the tortoise symbol will disappear.

#### 3.5.8 Lift adjuster

When lifting a load, the boom bends downwards and the working radius increases. In order to ensure that the load remains in the same position after it is lifted, the crane driver must control the derrick and the winch simultaneously.

The lift adjuster can minimize the extension of the working radius when lifting the load from the ground using a single joystick movement (only the hoisting gear is lifted).

	<p>If the weight of the load to be lifted is less, the effect of the lift adjuster is low.</p> <p>Do not use the lift adjuster when the rated load is less than 1.5 t (3,306.9 lbs) or when the object to be lifted deforms severely or when the boom head and the bottom block oscillate considerably owing to wind, etc.</p>
--	--

#### Operating the "lift adjuster"

1. The centre of the bottom block should be above the centre of gravity of the load.

Then increase the tension of the slinging rope slightly.

Setting the correct number of rope falls is extremely important to be able to control the lift adjuster precisely. Ensure that the number of rope falls set in the automatic safe load indicator matches the actual number.

**⚠️ WARNING!** The load may oscillate if the bottom block is not above the centre of gravity of the load.

**⚠️ WARNING!** Do not increase the tension of the slinging rope excessively. Excessive tension (over 0.2 t (441.0 lbs)) may lead to severe oscillation of the load.

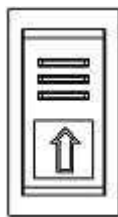

2. Press the "Lift adjuster" switch on the instrument panel.

⇒ The "Lift Adjuster"  icon will then appear on the graphical display, the alarm will be sounded at intervals and the engine speed will be increased automatically.

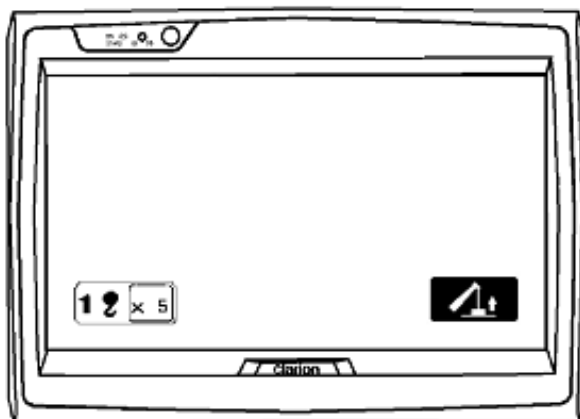

When operating the lift adjuster, the automatic safe load indicator controls the engine speed automatically. The accelerator pedal has no function.

3. Use the joystick to initiate the "Winch up" movement.

The automatic safe load indicator automatically controls both the movements "Winch up" and "Derrick up"

**NOTICE!** In case of an emergency, immediately move the joystick back to the neutral position to end the process.

**NOTICE!** If the joystick for the hoisting gear is moved back to the neutral position before completing the lifting process using the lift adjuster, the movements "Winch up" and "Derrick up" will be stopped. In such a case, the operation of the lift adjuster can be continued with the "Winch up" process.

<b>i</b>	<p>The lifting process using the lift adjuster is automatically ended when one of the following states prevail:</p> <ul style="list-style-type: none"><li>▶ Overload</li><li>▶ Activation of the anti-twoblock device</li><li>▶ Actuation of the "Lift adjuster" switch</li><li>▶ The lifting cylinder hits its mechanical end stop</li><li>▶ Other joystick movements are initiated (except hoisting gear or slewing movements)</li></ul> <p>1. Lift the load from the ground manually if the "lift adjuster" was automatically deactivated (except in case of overload or activated anti-twoblock device).</p>
----------	--

When the lifting process using the lift adjuster is completed, the "Lift adjuster" symbol will appear, the warning signal will stop sounding and the engine speed will drop to the normal idling speed.

### 3.5.9 Warnings and error codes

If the automatic safe load indicator (AML) interrupts crane operation, the character display of the automatic safe load indicator shows a warning code or error code.

Refer to the following tables for the description, cause and possible remedy.

#### Warning messages

"W----" warning codes provide information on the status of the crane and indicate how to return the mobile crane back to the correct operating mode.

Code	Description	Remedy
W0007	Another slewing process will lead to an overload (or an overload condition has already occurred) if outriggers are extended to different levels towards the left and the right. (Slow-stop function for slewing operations is activated)	Slew in the opposite direction, retract or lift the telescopic boom.
W0009	Jib LJ is outside the defined offset angle (falls short of smallest angle).	Lower the jib or raise the telescopic boom.
W0012	Crane does not have adequate stability towards the back.	Initiate measures for increasing stability towards the back (e.g. lower the telescopic boom or extend the telescope).
W0015	Anti-twoblock device is activated when the anti-twoblock device was overridden at the same time.	Lower the hook block.
W0016	The lifting capacity of the crane is not in the defined operating state. Incorrect combination of counterweight and outrigger selected.	Save the operating state correctly. Change the crane state to the correct operating state.
W0017	The lifting capacity of the crane is not in the defined operating state. Incorrect configuration of jib selected.	Save the operating state correctly. Change the crane state to the correct operating state.
W0022	Discrepancy between " <i>HTLJ fully retracted</i> " switch and HTLJ length sensor.	HTLJ length sensor defective or wrongly calibrated. The switch is defective. Internal AML error.
W0023	Stopped due to overload.	Take measures to reduce the load moment, e.g. raise the telescopic boom.
W0024	The anti-twoblock device was triggered.	Lower the hook block.
W0025	Stopped due to inadequate stability towards the back.	Initiate measures for increasing stability towards the back (e.g. lower the telescopic boom).
	<ul style="list-style-type: none"> <li>▪ If the sensors for the outrigger length are not installed: Undefined operating state of lifting capacity of crane.</li> </ul>	<ul style="list-style-type: none"> <li>▪ Enter correct values for counterweight and outriggers.</li> </ul>
	<ul style="list-style-type: none"> <li>▪ If the sensors for the outrigger length are installed: right- and left-hand outriggers are extended to different lengths.</li> </ul>	—
W0026	Upper limit of the telescopic boom angle is reached (working range limit).	Exit the working range limit function or lower the telescopic boom.
W0027	Lower limit of the telescopic boom angle is reached (working range limit).	Exit the working range limit function or raise the telescopic boom.
W0028	Maximum height of the telescopic boom or of the jib is reached (working range limit).	Exit the working range limit function or lower the telescopic boom or retract the telescope.

Code	Description	Remedy
W0029	Limit of the working radius is reached (working range limit).	Exit the working range limit function or raise the telescopic boom or retract the telescope.
W0030	Smallest offset angle of the jib LJ or of the hydraulically adjustable jib is reached.	Lower the jib or raise the boom.
W0034	Rope reserve of hoisting winch 1 is reached.	Wind hoisting rope of hoisting winch 1.
W0035	Rope reserve of hoisting winch 2 is reached.	Wind hoisting rope of hoisting winch 2.
W0039	Armrest is folded up.	Fold down the armrest.
W0040	Emergency operating mode (Emergency telescope switch is set to ON).	The crane must be operated carefully. See "Emergency operation".
W0041	Incorrect input signal on the counterweight transmitter.	—
W0042	Right-hand slew limit reached (working range limit).	Exit the working range limit function or slew towards the left.
W0043	Left-hand slew limit reached (working range limit).	Exit the working range limit function or slew towards the right.
W0045	The telescope cylinder has reached the end stop when telescoping in the manual mode.	Retract the telescope cylinder.
W0054	Luffing cylinder has reached the lower end stop.	Raise the telescopic boom.
W0055	Luffing cylinder has reached the upper end stop.	Lower the telescopic boom.
W0056	Another slewing process will lead to an overload (or an overload condition has already occurred) if outriggers are extended to different levels towards the left and the right. (Slow-stop function for slewing operations is deactivated)	Slew in the opposite direction, retract the telescope or lift the telescopic boom.
W0057	Front-right outrigger is retracted.	Extend the front-right outrigger.
W0058	Rear-right outrigger is retracted.	Extend the rear-right outrigger.
W0059	Front-left outrigger is retracted.	Extend the front-left outrigger.
W0060	Rear-left outrigger is retracted.	Extend the rear-left outrigger.
W0061	HTLJ is not pinned.	Pin HTLJ with remote control.
W0093	Telescopic boom connecting pin (B-pin) or telescope cylinder connecting pin (C-pin) cannot be controlled. Locking and unlocking sensors for the B-pin or C-pin are set to "OFF" on both sides.	Bring the crane control lever back to the neutral position. Then try again. When operated, the angle of the telescopic boom must be > 70°. When operated with the jib LJ, the angle of the telescopic boom must be > 75°.
W0094	Telescope cylinder locking bolt (C-pin) cannot be controlled.	Bring the crane control lever back to the neutral position. Then try again. When operated, the angle of the telescopic boom must be > 70°. When operated with the jib LJ, the angle of the telescopic boom must be > 75°.



Code	Description	Remedy
W0095	Automatic telescoping is not possible since the speed of the telescopic boom connecting pin (B-pin) is extremely slow.	Try again with crane control lever fully extended and maximum engine speed. The "Deactivate the slow telescope" mode function can be used at temperatures > 0° C.
W0097	The maximum wind speed (i.e. wind gusts) exceeds the limit for safe working.	Stop the crane operation and secure the telescopic boom.
W0099	Smallest offset angle of the jib LJ with Power System reached.	Lower jib LJ.
W0102	The "Deactivate the slow telescope" mode is selected.	—
W0105	Telescopic boom is dismantled.	—
W0106	Derrick speed is reduced due to the Slow-Stop function.	—
W0108	Rotation speed is reduced due to the Slow-Stop function.	—
W0110	Telescoping with jib LJ may only take place in setup mode. Note: After 10 seconds the display changes back to the normal state.	To telescope, switch to the setup mode for the jib LJ.
W0113	The crane position has reached the limiting value for the luffing cylinder.	Raise the telescopic boom or retract the telescope.
W0121	Luffing cylinder has reached the end stop.	Lower the telescopic boom.
W0173	Counterweight cylinder is extended, but the slew movement is selected.	Set the counterweight correctly.
W0176	Operation with jib LJ: Confirm number of rope falls	—
W0179	The AML detects an active superstructure locking bolt even if the superstructure is not "towards the back".	Check the superstructure locking bolt and the rotation angle sensor.
W0180	The hook block may touch the telescopic boom.	Lower the telescopic boom.
W0182	Hoisting rope is not sufficiently unwound to lower the HTLJ tip, in the following situation: <ul style="list-style-type: none"> <li>▪ HTLJ setup mode is switched on.</li> <li>▪ HTLJ offset angle is &lt; 2°.</li> <li>▪ The telescopic boom is retracted completely.</li> </ul>	Unwind hoisting rope more than 16 cm.
W0183	1: The counterweight locking and unlocking sensors are active = sensor errors.	Rectify the error.
	2: The counterweight is lowered and the "Slew the superstructure" function was selected.	Retract the counterweight cylinder.
	<b>Note: On the AML display, check whether error 1 or 2 has occurred. Check the digital inputs.</b>	

Code	Description	Remedy
W0184	The radio control is activated. Operation with crane control levers is not possible.	—
W0185	When the counterweight is mounted and the length of the counterweight cylinder is at its maximum, the superstructure slews by 180° (downwards) beyond the superstructure position.	Stop the slewing movement and slew in the opposite direction.
W0188	A telescopic section sensor (Tele-ID sensor) does not function. <b>Note: The telescope control continues functioning normally since the common sensor for all telescope parts is still functioning.</b> If the common sensor for all telescope parts does not function, the telescope control stops and an error message is displayed.	Rectify the error in the telescope part sensor. Rectify the cable fault. Rectify the AML circuit fault.
W0191	When the AML is activated or the setup condition is changed, the "Override automatic safe load indicator" key-operated switch is not in the neutral position.	Switch the "Override automatic safe load indicator" key-operated switch to the neutral position.
W0195	Telescoping with Power System may only take place in setup mode. Note: After 10 seconds the display changes back to the normal state.	To telescope, switch to the setup mode for the Power System.
W0199	AML identifies the connected Power System, AML is however not in Power System mode.	Switch to Power System mode.
W0200	Power System: Excessive telescopic boom angle. Power System may only be stored when the telescopic boom is stored.	Lower the telescopic boom.
W0201	Power System: Telescopic boom angle too small. Power System may only be slackened when the telescopic boom is erect.	Raise the telescopic boom.
W0202	Power System: Offset angle of jib too small.	Lower jib.
W0203	Power System: Offset angle of jib too big.	Raise the jib.
W0204	Power System is not fully erect.	Fully erect the Power System (extend cylinder of Power System).
W0217	Counterweight is stored on carrier, hydraulic lines not yet disconnected.	Disconnect hydraulic lines to counterweight.
W0218	Counterweight is not in the upper position.	Retract counterweight cylinder.
W0230	The following functions must not be performed simultaneously: <ul style="list-style-type: none"> <li>▪ Set up the Power System.</li> <li>▪ Wind / unwind the hoisting winch of the Power System.</li> <li>▪ Telescope the telescopic boom.</li> </ul>	Carry out the functions individually.

Code	Description	Remedy
W0231	The remote control is activated. Operation with crane control levers is not possible.	—
W0246	Excessive tension in the rope of the Power System. When a load is slung, for safety reasons the following functions must <b>not</b> be performed: <ul style="list-style-type: none"> <li>▪ Pretensioning the telescopic boom.</li> <li>▪ Release the pretension of the telescopic boom.</li> </ul>	Decrease the load.
W0247	Operation of Power System and HTLJ. The following functions may only be carried out when the HTLJ is fully retracted: <ul style="list-style-type: none"> <li>▪ Telescope the telescopic boom.</li> <li>▪ Pretensioning the telescopic boom.</li> <li>▪ Release the pretension of the telescopic boom.</li> </ul>	Fully retract the HTLJ.
W0248	Power System: Contaminated oil filter.	Check oil filter, check oil.
W0255	The smallest offset angle of the hydraulically adjustable jib has been reached. For safety reasons, the offset angle of the jib is limited: <ul style="list-style-type: none"> <li>▪ Stability at rear.</li> <li>▪ Risk of hook block colliding with the telescopic boom.</li> </ul>	Lower the jib or the telescopic boom.
W0256	The hydraulically adjustable jib is located outside the defined offset angle (smallest angle undercut). For safety reasons, the offset angle of the jib is limited: <ul style="list-style-type: none"> <li>▪ Stability at rear.</li> <li>▪ Risk of hook block colliding with the telescopic boom.</li> </ul>	Lower the jib or the telescopic boom.
W0263	The smallest offset angle of the jib LJ has been reached.	Lower the jib or raise the telescopic boom.
W0264	The largest offset angle of the jib LJ has been reached.	Raise the jib or lower the telescopic boom.
W0265	Setup mode for jib LJ: The largest offset angle of the jib LJ has been reached (80°).	Raise the jib or lower the telescopic boom.
W0266	Setup mode for jib LJ: The smallest angle of the lower luffing mast is reached.	Lower the jib or raise the telescopic boom.
W0267	LJ jib: Minimum stroke of the fallback cylinder is reached.	Lower the jib or raise the telescopic boom.

Code	Description	Remedy
W0268	Setup mode for jib LJ: The top luffing pulley is fully retracted into the luffing pulley assembly.	—
W0269	Jib LJ, suspended mounting: The top luffing pulley is not correctly retracted into the support block.	Check whether the top luffing pulley has been correctly retracted into the support block.
W0275	Setup mode for jib LJ: Speed reduction of hoisting winch 2 because top luffing pulley is being retracted into the luffing pulley assembly.	—
W0276	Jib LJ, suspended mounting: The largest angle of the lower luffing mast is reached.	Raise the jib or lower the telescopic boom.
W0278	Power System: Automatic switch to setup mode because pre-tension is too low.	Reset the pre-tension again using the bracing winch.
W0279	Power System: Switch automatically to setup mode because brake of bracing winch is not correctly closed.	Reset the pre-tension again using the bracing winch.
W0333	Confirmation or change of the displayed setup condition.	Compare the displayed setup condition (counterweight, outrigger base, jib) with the actual setup condition of the crane. If they match, confirm with the "Enter" key or change with the corresponding setup function keys.
W0334	Stopped due to risk of collision between the hook block and working floodlights.	Lower the telescopic boom.
W0999	Voltage of AML buffer battery too low. This message appears only when switching on.	Replace AML buffer battery.

### Communication error

"E1---" error codes show communication errors between the display device or transmitter and the control unit.

If this error type occurs, crane operation will be switched off.

Contact your local service partner.

Code	Description	Cause
E1001	The transmitter connected to serial port 1 is not receiving any information from the AML.	The communication line between the transmitter and the AML is broken. Error of the transmitter connected to serial port 1. Internal AML error.
E1002	The transmitter connected to serial port 2 is not receiving any information from the AML.	The communication line between the transmitter and the AML is broken. Error of the transmitter connected to serial port 2. Internal AML error.
E1003	The AML is not receiving any information from the transmitter connected to serial port 1.	The communication line between the transmitter and the AML is broken. Error of the transmitter connected to serial port 1. Internal AML error.
E1004	The AML is not receiving any information from the transmitter connected to serial port 2.	The communication line between the transmitter and the AML is broken. Error of the transmitter connected to serial port 2. Internal AML error.
E1005	Internal error in the transmitter connected to serial port 1.	Cable fault. Error of the transmitter connected to serial port 1.
E1006	Internal error in the transmitter connected to serial port 2.	Cable fault. Error of the transmitter connected to serial port 2.
E1007	The transmitter connected to serial port 1 has identified data errors in the data from the AML.	The communication line between the transmitter and the AML is broken or incorrectly connected. Error in the receiver circuit of the AML. Fault in the transmitter circuit of the transmitter.
E1008	The transmitter connected to serial port 2 has identified data errors in the data from the AML	The communication line between the transmitter and the AML is broken or incorrectly connected. Error in the receiver circuit of the AML. Fault in the transmitter circuit of the transmitter.
E1009	The AML has identified data errors in the data from the transmitter connected to serial port 1.	The communication line between the transmitter and the AML is broken or incorrectly connected. Error in the receiver circuit of the AML. Fault in the transmitter circuit of the transmitter.
E1010	The AML has identified data errors in the data from the transmitter connected to serial port 2.	The communication line between the transmitter and the AML is broken or incorrectly connected. Error in the receiver circuit of the AML. Fault in the transmitter circuit of the transmitter.

Code	Description	Cause
E1011	The type of transmitter connected to serial port 1 is wrong in the received data.	Error of the transmitter connected to serial port 1. Incorrect connection of the communication line.
E1012	The type of transmitter connected to serial port 2 is wrong in the received data.	Error of the transmitter connected to serial port 2. Incorrect connection of the communication line.
E1013	The transmitter connected to serial port 3 is not receiving any information from the AML.	The communication line between the transmitter and the AML is broken. Error of the transmitter connected to serial port 3. Internal AML error.
E1014	The AML is not receiving any information from the transmitter connected to serial port 3.	The communication line between the transmitter and the AML is broken. Error of the transmitter connected to serial port 3. Internal AML error.
E1015	Internal error in the transmitter connected to serial port 3.	Error in the transmitter.
E1016	The transmitter connected to serial port 3 has identified data errors in the data from the AML.	Error in the transmitter. Wrong communication setting.
E1017	The AML has identified data errors in the data from the transmitter connected to serial port 3.	Error in the transmitter. Wrong communication setting.
E1018	The type of transmitter connected to serial port 3 is wrong in the received data.	Wrong transmitter type. Error in the transmitter. Incorrect connection of the communication line.
E1021	The AML detects data errors in the data of the display module.	Error in the display module. Incorrect connection of the communication line.
E1022	The display module cannot receive any information from the AML.	AML is not functioning. Incorrect connection of the communication line. Internal AML error.
E1024	Internal error in the display module.	Error in the display module.
E1025	AML is not receiving any information from the display module.	The display module does not function. Incorrect connection of the communication line.
E1031	The boom head transmitter is not receiving any information from the superstructure frame transmitter.	The communication line between the transmitters of the boom head and superstructure frame has been interrupted or is incorrectly connected. Error in the boom head transmitter. Error in the superstructure frame transmitter.

Code	Description	Cause
E1032	The AML is not receiving any information from the boom head transmitter.	The communication line between the transmitter and the AML is broken or incorrectly connected. Error in the boom head transmitter. Internal AML error.
E1033	Internal error in the boom head transmitter.	Cable fault. Error in the boom head transmitter.
E1034	Boom head transmitter has identified a data error in the data from the superstructure frame transmitter.	The communication line between the transmitters of the boom head and superstructure frame has been interrupted or is incorrectly connected. Internal AML error. Fault in the transmitter circuit of the transmitter.
E1035	The AML has detected data errors in the data from the boom head transmitter.	The communication line between the transmitter and the AML is broken or incorrectly connected. Internal AML error. Fault in the transmitter circuit of the transmitter.
E1036	The type of boom head transmitter in the received data is incorrect.	Communication line is interrupted or incorrectly connected. Error in the boom head transmitter.
E1037	The transmitter of the jib (LJ, FJ, HTLJ) is not receiving any information from the boom head transmitter.	The communication line between the transmitters of the boom head and the jib (LJ, FJ, HTLJ) has been interrupted or is incorrectly connected. Error in the boom head transmitter. Error in the superstructure frame transmitter.
E1038	The AML is not receiving any information from the transmitter of the jib (LJ, FJ, HTLJ).	The communication line between the transmitter and the AML is broken or incorrectly connected. Error in the transmitter of the jib (LJ, FJ, HTLJ). Internal AML error.
E1039	Internal error in the transmitter of the jib (LJ, FJ, HTLJ).	Cable fault. Error in the transmitter of the jib (LJ, FJ, HTLJ).
E1040	The transmitter of the jib (LJ, FJ, HTLJ) has identified a data error in the data from the boom head transmitter.	The communication line between the transmitters of the boom head and the jib (LJ, FJ, HTLJ) has been interrupted or is incorrectly connected. Error in the receiver circuit of the AML. Fault in the transmitter circuit of the transmitter.
E1041	The AML has identified data errors in the data from the transmitter of the jib (LJ, FJ, HTLJ).	The communication line between the transmitter and the AML is broken or incorrectly connected. Error in the receiver circuit of the AML. Fault in the transmitter circuit of the transmitter.



---

Code	Description	Cause
E1042	The type of transmitter for the jib (LJ, FJ, HTLJ) in the data received is incorrect.	Error in the transmitter of the jib (LJ, FJ, HTLJ). Incorrect connection of the communication line.

### Sensor error

"E2---" error codes indicate errors in sensors, control levers or hydraulic valves.

If this error type occurs, crane operation will be switched off.

Contact your local service partner.

Code	Description	Cause / remedy
E2003	Error in the boom length sensor. The input value of the sensor is outside the normal range. The normal range is 1.1-21 mA (is converted to a voltage of 0.25-4.75 V in the AML).	Sensor error. Sensor cable broken or short-circuit. Internal AML error.
E2004	Error in the boom angle sensor. The input value of the sensor is outside the normal range. The normal range is 1.1-21 mA (is converted to a voltage of 0.25-4.75 V in the AML).	Sensor error. Sensor cable broken or short-circuit. Internal AML error.
E2005	Error in the sensor "Boom length HTLJ". The input value of the sensor is outside the normal range. The normal range is 0.25-4.75 V.	Sensor error. Sensor cable broken or short-circuit. Internal AML error.
E2006	Error in the sensor "Offset angle of the jib". The input value of the sensor is outside the normal range. The normal range is 0.25-4.75 V.	Sensor error. Sensor cable broken or short-circuit. Internal AML error.
E2007	Error in the sensor "Angle of the jib LJ". The input value of the sensor is outside the normal range. The normal range is 0.25-4.75 V.	Sensor error. Sensor cable broken or short-circuit. Internal AML error.
E2009	Error in the sensor "Length of the front-right outrigger". The input value of the sensor is outside the normal range. The normal range is 0.25-4.75 V.	Sensor error. Sensor cable broken or short-circuit. Fault in the circuit of the outrigger transmitter.
E2010	Error in the sensor "Length of the rear-right outrigger". The input value of the sensor is outside the normal range. The normal range is 0.25-4.75 V.	Sensor error. Sensor cable broken or short-circuit. Fault in the circuit of the outrigger transmitter.
E2011	Error in the sensor "Length of the front-left outrigger". The input value of the sensor is outside the normal range. The normal range is 0.25-4.75 V.	Sensor error. Sensor cable broken or short-circuit. Fault in the circuit of the outrigger transmitter.
E2012	Error in the sensor "Length of the rear-left outrigger". The input value of the sensor is outside the normal range. The normal range is 0.25-4.75 V.	Sensor error. Sensor cable broken or short-circuit. Fault in the circuit of the outrigger transmitter.
E2022	Error in the sensor "Telescope cylinder length". The input value of the sensor is outside the normal range. The normal range is 1.1-21 mA (is converted to a voltage of 0.25-4.75 V in the AML).	Sensor error. Sensor cable broken or short-circuit. Internal AML error.

Code	Description	Cause / remedy
E2023	<p>Load moment error. Calculated load (weight) becomes negative ("minus").</p> <p><b>Note: Load moment-reducing movements are possible. No entry in the error memory is created.</b></p>	<p>Fault in the pressure sensor of the lifting cylinder. Sensor cable broken or short-circuit. Incorrectly configured setting. Internal AML error.</p>
E2030	<p>Error in the pressure sensor on the piston side. The input value of the sensor is outside the normal range. The normal range is 1.1-21 mA (is converted to a voltage of 0.25-4.75 V in the AML).</p>	<p>Fault in the pressure sensor of the luffing cylinder. Sensor cable broken or short-circuit. Incorrectly configured setting. Internal AML error.</p>
E2031	<p>Error in the pressure sensor on the rod side. The input value of the sensor is outside the normal range. The normal range is 1.1-21 mA (is converted to a voltage of 0.25-4.75 V in the AML).</p>	<p>Fault in the pressure sensor of the luffing cylinder. Sensor cable broken or short-circuit. Incorrectly configured setting. Internal AML error.</p>
E2041	<p>Error in the crane control "Left/front-rear crane control lever" (analogue). The input value of the "Left/front-rear crane control lever" lies outside the normal range. The normal range is equivalent to a voltage of between 0.25 and 4.75 V.</p> <p><b>Note: The "Left/front-rear crane control lever" cannot be operated.</b></p>	<p>Error in the crane control lever. Cable fault. Internal AML error.</p>
E2042	<p>Error in the crane control "Left/left-right crane control lever" (analogue). The input value of the "Left/left-right joystick crane control lever" lies outside the normal range. The normal range is equivalent to a voltage of between 0.25 and 4.75 V.</p> <p><b>Note: The "Left/left-right crane control lever" cannot be operated.</b></p>	<p>Error in the crane control lever. Cable fault. Internal AML error.</p>
E2043	<p>Error in the crane control "Right/front-rear crane control lever" (analogue). The input value of the "Right/front-rear crane control lever" lies outside the normal range. The normal range is equivalent to a voltage of between 0.25 and 4.75 V.</p> <p><b>The "Right/front-rear crane control lever" cannot be operated.</b></p>	<p>Error in the crane control lever. Cable fault. Internal AML error.</p>

Code	Description	Cause / remedy
E2044	<p>Error in the crane control "Right/right-left crane control lever" (analogue).</p> <p>The input value of the "Right/right-left crane control lever" lies outside the normal range.</p> <p>The normal range is equivalent to a voltage of between 0.25 and 4.75 V.</p> <p><b>Note: Operation of the "Right/left-right crane control lever" is not possible.</b></p>	<p>Error in the crane control lever.</p> <p>Cable fault.</p> <p>Internal AML error.</p>
E2046	<p>Error in the crane control "Foot pedal 1" (analogue).</p> <p>The input value of the "Foot pedal 1" lies outside the normal range.</p> <p>The normal range is equivalent to a voltage of between 0.25 and 4.75 V.</p> <p><b>Note: Operation of "Foot pedal 1" is not possible.</b></p>	<p>Error in foot pedal 1.</p> <p>Cable fault.</p> <p>Internal AML error.</p>
E2048	<p>Error in the crane control "Left/front-rear crane control lever" (discrepancy).</p> <p>If the direction contact of the "Left/front-rear crane control lever" is set to "OFF", the analogue input value of the "Left/front-rear crane control lever" is not in the neutral range.</p> <p><b>Note: The "Left/front-rear crane control lever" cannot be operated.</b></p>	<p>Error in the crane control lever.</p> <p>Cable fault.</p> <p>Internal AML error.</p>
E2049	<p>Error in the crane control "Left/left-right crane control lever" (discrepancy).</p> <p>When the direction contact on the "Left/left-right crane control lever" is set to "OFF", the analogue input value of the crane control "Left/left-right crane control lever" is not in the neutral range.</p> <p><b>Note: The "Left/left-right crane control lever" cannot be operated.</b></p>	<p>Error in the crane control lever.</p> <p>Cable fault.</p> <p>Internal AML error.</p>
E2050	<p>Error in the crane control "Right/front-rear crane control lever" (discrepancy).</p> <p>When the direction contact of the "Right/front-rear crane control lever" is set to "OFF", the analogue input value of the "Right/front-rear crane control lever" is not in the neutral range.</p> <p><b>Note: The "Right/front-rear crane control lever" cannot be operated.</b></p>	<p>Error in the crane control lever.</p> <p>Cable fault.</p> <p>Internal AML error.</p>
E2051	<p>Error in the crane control "Right/right-left crane control lever" (discrepancy).</p> <p>When the direction contact on the "Right/left-right crane control lever" is set to "OFF", the analogue input value of the crane control "Right/left-right crane control lever" is not in the neutral range.</p> <p><b>Note: Operation of the "Right/left-right crane control lever" is not possible.</b></p>	<p>Error in the crane control lever.</p> <p>Cable fault.</p> <p>Internal AML error.</p>

Code	Description	Cause / remedy
E2053	<p>Error in the crane control "Foot pedal 1" (discrepancy).</p> <p>When the direction contact on the "Foot pedal 1" is set to "OFF", the analogue input value of the crane control "Foot pedal 1" is not in the neutral range.</p> <p><b>Note: Operation of "Foot pedal 1" is not possible.</b></p>	<p>Error in foot pedal 1.</p> <p>Cable fault.</p> <p>Internal AML error.</p>
E2057	<p>Power System: Error in winch brake (discrepancy).</p> <p>Error in diagnosis between target state and actual state.</p> <p>(Output solenoid valve ON and winch brake CLOSED, or output solenoid valve OFF and winch brake OPEN)</p>	<p>Sensor error.</p> <p>Sensor cable broken or short-circuit.</p> <p>Circuit board error.</p> <p>Error in solenoid valve.</p>
E2058	<p>Power System: Maximum permitted rope force in Power System exceeded.</p>	<p>Error in the dynamometer.</p> <p>Cable fault.</p> <p>Internal AML error.</p>
E2061	<p>Output error in the rotation control.</p> <p>The AML detects the current flow in the rotation control even if the monitored current output is not activated.</p> <p><b>Note: Rotation operations are not possible.</b></p>	<p>Cable fault.</p> <p>Internal AML error.</p>
E2062	<p>Output error in control of hoisting winch 1.</p> <p>The AML detects the current flow even if the monitored current output is not activated.</p> <p><b>Note: A crane movement is not possible.</b></p>	<p>Cable fault.</p> <p>Internal AML error.</p>
E2063	<p>Output error in control of hoisting winch 2.</p> <p>The AML detects the current flow even if the monitored current output is not activated.</p> <p><b>Note: A crane movement is not possible.</b></p>	<p>Cable fault</p> <p>Internal AML error.</p>
E2064	<p>Output error in the telescope cylinder control.</p> <p>The AML detects the current flow even if the monitored current output is not activated.</p> <p><b>Note: A crane movement is not possible.</b></p>	<p>Cable fault.</p> <p>Internal AML error.</p>
E2065	<p>Output error in the luffing cylinder control.</p> <p>The AML detects the current flow even if the monitored current output is not activated.</p> <p><b>Note: A crane movement is not possible.</b></p>	<p>Cable fault.</p> <p>Internal AML error.</p>
E2066	<p>Output error in the control of the jib (HLJ, HTLJ).</p> <p>The AML detects the current flow even if the monitored current output is not activated.</p> <p><b>Note: A crane movement is not possible.</b></p>	<p>Cable fault.</p> <p>Internal AML error.</p>

Code	Description	Cause / remedy
E2067	Output error in the hydraulic pump 1 control. The AML detects the current flow even if the monitored current output is not activated. <b>Note: A crane movement is not possible.</b>	Cable fault. Internal AML error.
E2068	Output error in the hydraulic pump 2 control. The AML detects the current flow even if the monitored current output is not activated.	Cable fault. Internal AML error.
E2081	Error in the rotation movement. A rotation movement (to the right) is detected even though the AML has not activated the rotate valve. <b>Note: Rotate operations to the right are not possible.</b>	Error in the hydraulic circuit. Error in solenoid valve. Error in the angle of rotation sensor. Internal AML error.
E2082	Movement error in hoisting winch 1. A movement of the 1st hoisting winch (upwards) is detected without the AML having activated the valve of hoisting winch 1. <b>Note: Lifting with hoisting winch 1 is not possible.</b>	Error in the hydraulic circuit. Error in solenoid valve. Error in sensor for speed of hoisting winch 1. Internal AML error.
E2083	Movement error in hoisting winch 2. A movement of the 2nd hoisting winch (upwards) is detected without the AML having activated the valve of hoisting winch 2. <b>Note: Lifting with hoisting winch 2 is not possible.</b>	Error in the hydraulic circuit. Error in solenoid valve. Error in sensor for speed of hoisting winch 2. Internal AML error.
E2084	Error during telescope movement. A telescope movement is detected even if the AML has not activated the telescope valve. <b>Note: The telescopic cylinder cannot be extended.</b>	Error in the hydraulic circuit. Error in solenoid valve. Error in the sensor for the telescope cylinder length. Internal AML error.
E2085	Error in the derrick movement. A "Raise the boom" movement is detected even if the AML has not activated the derrick valve. <b>Note: The telescopic boom cannot be raised.</b>	Error in the hydraulic circuit. Error in solenoid valve. Error in the boom angle sensor. Internal AML error.
E2086	Error when moving the jib. An increase in the offset angle of the jib is detected even though the AML has not activated the offset angle valve. <b>Note: The offset angle of the jib cannot be increased.</b>	Error in the hydraulic circuit. Error in solenoid valve. Error in offset angle sensor of the jib. Fault in the circuit of the luffing fly jib transmitter.
E2087	Error in a telescope ID sensor. The telescope ID sensors of multiple telescopes are all active simultaneously.	Error in a telescope ID sensor. Cable fault. Internal AML error.

Code	Description	Cause / remedy
E2088	Sensor telescope ID of telescope 2 is not working. After identifying the telescope 3(1), the telescope 1(3) is identified; telescope 2 is skipped. <b>Note: Telescoping is not possible.</b>	Errors in the telescope ID sensor of telescope 1, 2 or 3. Cable fault. Internal AML error.
E2089	Error in a telescope ID sensor. If the telescope cylinder is not connected to a boom part and a telescope identification has just been completed, the value for the length of the telescope cylinder will not coincide with the current position of the identified telescope.	Error in the cylinder length sensor or incorrect setting. Error in a telescope ID sensor or incorrect setting. Cable fault. Internal AML error or incorrectly saved boom state.
E2090	B-pin error. B-pin cannot be locked or unlocked. Sensor "B-pin locked" and sensor "B-pin unlocked" are both activated.	Error in the B-pin locked/unlocked sensor. Cable fault. Internal AML error.
E2091	C-pin error. C-pin cannot be locked or unlocked. Sensor "C-pin locked" and sensor "C-pin unlocked" are both activated.	Error in the C-pin locked/unlocked sensor. Cable fault. Internal AML error.
E2092	B and C-pin errors. Both the B-pin and C-pin sensors are in the unlocked state.	Errors in the B-pin and C-pin locked/unlocked sensor. Cable fault. Internal AML error.
E2093	Errors in the telescope ID sensor and the C-pin state. Telescope ID sensor is not active and "C-pin unlocked" sensor becomes inactive.	Errors in the telescope ID sensor or in the C-pin locked/unlocked sensor. Cable fault. Internal AML error.
E2094	The telescope needs to be reset. This error message appears after replacing an AML or when the buffer battery of the AML has extremely low voltage. <b>Note: Telescoping is not possible. Other crane movements are possible.</b>	Call the Telescope reset menu.
E2095	Both direction contacts on the "Left/front-rear crane control lever" are activated. <b>Note: The "Left/front-rear crane control lever" cannot be operated. Other crane movements are possible.</b>	Error in the "Left/front-rear crane control lever". Cable fault. Internal AML error.
E2096	Both direction contacts of the "Left/left-right crane control lever" are activated. <b>Note: The "Left/left-right crane control lever" cannot be operated. Other crane movements are possible.</b>	Error in the "Left/left-right crane control lever". Cable fault. Internal AML error.
E2097	Both direction contacts on the "Right/front-rear crane control lever" are activated. <b>Note: The "Right/front-rear crane control lever" cannot be operated. Other crane movements are possible.</b>	Error in the "Right/front-rear crane control lever". Cable fault. Internal AML error.



Code	Description	Cause / remedy
E2098	Both direction contacts of the "Right/left-right crane control lever" are activated. <b>Note: Operation of the "Right/left-right crane control lever" is not possible. Other crane movements are possible.</b>	Error in the "Right/left-right crane control lever". Cable fault. Internal AML error.
E2103	Error in the rotation movement. A rotation movement (to the left) is detected even though the AML has not activated the rotate valve. <b>Note: Rotate operations to the left are not possible.</b>	Error in the hydraulic circuit. Cable fault. Error in the angle of rotation sensor. Internal AML error.
E2104	Error in movement of hoisting winch 1. A movement of the 1st hoisting winch (downwards) is detected without the AML having activated the valve of hoisting winch 1. <b>Note: Hoisting winch 1 cannot be unwound.</b>	Error in the hydraulic circuit. Error in solenoid valve. Error in sensor for speed of hoisting winch 1. Internal AML error.
E2105	Error in movement of hoisting winch 2. A movement of the 2nd hoisting winch (downwards) is detected without the AML having activated the valve of hoisting winch 2. <b>Note: Hoisting winch 2 cannot be unwound.</b>	Error in the hydraulic circuit. Error in solenoid valve. Error in sensor for speed of hoisting winch 2. Internal AML error.
E2106	Error during telescope movement. A retraction movement is detected even though the AML has not activated the telescope valve. <b>Note: The telescopic cylinder cannot be retracted.</b>	Error in the hydraulic circuit. Error in solenoid valve. Error in the sensor for the telescope cylinder length. Internal AML error.
E2107	Error in the derrick movement. A "Lower the boom" movement is detected even if the AML has not activated the derrick valve. <b>Note: The boom cannot be lowered.</b>	Error in the hydraulic circuit. Error in solenoid valve. Error in the boom angle sensor. Internal AML error.
E2108	Error when moving the jib. A reduction in the offset angle of the jib is detected even though the AML has not activated the offset angle valve. <b>Note: The offset angle of the jib cannot be decreased.</b>	Error in the hydraulic circuit. Error in solenoid valve. Error in offset angle sensor of the jib. Fault in the circuit of the luffing fly jib transmitter.
E2109	Error in the telescope movement of the HTLJ jib. A telescopic movement of the HTLJ jib is detected even if the AML has not activated the telescope valve of the HTLJ. <b>Note: The telescopic cylinder of the HTLJ jib cannot be retracted.</b>	Error in the hydraulic circuit. Error in solenoid valve. Error in the sensor for the telescope cylinder length HTLJ. Fault in the circuit of the luffing fly jib transmitter.
E2110	Error in the angle of rotation channel A sensor. The input current of the rotation angle sensor is outside the normal range (1.1-21.6 mA).	Error in the angle of rotation sensor. Cable fault. Internal AML error.

Code	Description	Cause / remedy
E2111	Error in the angle of rotation channel B sensor. The input current of the rotation angle sensor is outside the normal range (1.1-21.6 mA).	Error in the angle of rotation sensor. Cable fault. Internal AML error.
E2112	Deviation error in a rotation angle sensor. The difference between the output currents of rotation angle sensors channel A and channel B lies outside the normal range.	Error in the angle of rotation sensor. Cable fault. Internal AML error.
E2113	The input current of the anti-twoblock device is outside the normal range (0.6-11.5 mA).	Error in the anti-twoblock device. The anti-twoblock device is not available. Cable fault. Internal AML error.
E2115	Sensor telescope ID of telescope 3 is not working. After identifying the telescope 4(2), the telescope 2(4) is identified; telescope 3 is skipped. <b>Note: Telescoping is not possible.</b>	Errors in the telescope ID sensor of telescope 2, 3 or 4. Cable fault. Internal AML error.
E2116	Sensor telescope ID of telescope 4 is not working. After identifying the telescope 5(3), the telescope 3(5) is identified; telescope 4 is skipped. <b>Note: Telescoping is not possible.</b>	Errors in the telescope ID sensor of telescope 3, 4 or 5. Cable fault. Internal AML error.
E2117	Sensor telescope ID of telescope 5 is not working. After identifying the telescope 6(4), the telescope 4(6) is identified; telescope 5 is skipped. <b>Note: Telescoping is not possible.</b>	Errors in the telescope ID sensor of telescope 4, 5 or 6. Cable fault. Internal AML error.
E2119	B-pin error. C-pin is unlocked and B-pin sensor becomes inactive.	Error in the telescope ID sensor and the B-pin locked/unlocked sensor. Cable fault. Internal AML error.
E2133	Telescope ID sensor: Error on one side. The ID combination on one side is wrong. <b>Note: The automatic mode is continued with the error-free side.</b>	Error in the telescope ID sensor. Cable fault. Internal AML error.
E2134	Telescope ID sensor: Error on both sides. The ID combination on both sides is wrong. <b>Note: Automatic mode is stopped. A movement is possible only in the emergency operating mode.</b>	Error in the telescope ID sensor. Cable fault. Internal AML error.
E2135	Locking and unlocking sensors for the B-pin on one side are set to "OFF". <b>Note: The automatic mode is continued at reduced speed with the help of the telescope cylinder length and the error-free pins.</b>	Error in the B-pin locked/unlocked sensor. Cable fault. Internal AML error.

Code	Description	Cause / remedy
E2136	Locking and unlocking sensors for B-pin on one side or both sides are set to "ON".	Error in the B-pin locked/unlocked sensor. Cable fault. Internal AML error.
E2137	Locking and unlocking sensors for the C-pin on one side are set to "OFF". <b>Note: The automatic mode is continued at reduced speed with the help of the telescope cylinder length and the error-free pins.</b>	Error in the C-pin locked/unlocked sensor. Cable fault. Internal AML error.
E2138	Locking and unlocking sensors for C-pin on one side or both sides are set to "ON".	Error in the C-pin locked/unlocked sensor. Cable fault. Internal AML error.
E2141	When the AML is activated or if emergency operation no longer applies, the "Hoisting winch 1 up" button on the remote control is not in a neutral position.	Switch button to neutral position. Button error. Short circuit of line. Circuit board error.
E2142	When the AML is activated or if emergency operation no longer applies, the "Hoisting winch 1 down" button on the remote control is not in a neutral position.	Switch button to neutral position. Button error. Short circuit of line. Circuit board error.
E2143	When the AML is activated or if emergency operation no longer applies, the "Raise HTLJ" button on the remote control is not in a neutral position.	Switch button to neutral position. Button error. Short circuit of line. Circuit board error.
E2144	When the AML is activated or if emergency operation no longer applies, the "Lower the HTLJ" button on the remote control is not in a neutral position.	Switch button to neutral position. Button error. Short circuit of line. Circuit board error.
E2151	When the AML is activated or if emergency operation no longer applies, a "Counterweight" button on the remote control is not in a neutral position.	Switch button to neutral position. Button error. Short circuit of line. Circuit board error.
E2152	When the AML is activated or if emergency operation no longer applies, the "Hoisting winch 2 up" button on the remote control is not in a neutral position.	Switch button to neutral position. Button error. Short circuit of line. Circuit board error.
E2153	When the AML is activated or if emergency operation no longer applies, the "Hoisting winch 2 down" button on the remote control is not in a neutral position.	Switch button to neutral position. Button error. Short circuit of line. Circuit board error.
E2154	When the AML is activated or if emergency operation no longer applies, a "Boom-Dismantling" button on the remote control is not in a neutral position.	Switch button to neutral position. Button error. Short circuit of line. Circuit board error.
E2157	When the AML is activated or if emergency operation no longer applies, the "Set Up Power System" button is not in a neutral position.	Switch button to neutral position. Button error. Short circuit of line. Circuit board error.

Code	Description	Cause / remedy
E2158	When the AML is activated or if emergency operation no longer applies, the "Set Down Power System" button is not in a neutral position.	Switch button to neutral position. Button error. Short circuit of line. Circuit board error.
E2161	When the AML is activated or if emergency operation no longer applies, the "Power System Winch Up" button is not in a neutral position.	Switch button to neutral position. Button error. Short circuit of line. Circuit board error.
E2162	When the AML is activated or if emergency operation no longer applies, the "Power System Winch Down" button is not in a neutral position.	Switch button to neutral position. Button error. Short circuit of line. Circuit board error.
E2176	Operation of Power System: If, when the telescopic boom is extended, the rope tension of the Power System exceeds the permitted value.	1) Error in pressure sensor, sensor cable broken or short circuit, circuit board error. 2) Incorrect movement of PS winch 3) Brake of Power System winch not opened.
E2185	Output error for control of the Power System. Although the output to the proportional valve for control of the Power System is not activated, there is current to the proportional valve.	Error in solenoid valve. Cable fault/short circuit. Circuit board error.
E2188	Error in the angle sensor of the boom head. The input value of the sensor is outside the normal range. The normal range is 0.25-4.75 V.	Sensor error. Sensor cable broken or short-circuit. Internal AML error.
E2191	Error in the pressure sensor of the fall-back cylinder of the jib LJ. The input value of the sensor is outside the normal range. The normal range is 0.25-4.75 V.	Sensor error. Sensor cable broken or short-circuit. Internal transmitter error.
E2192	Error in the dynamometer of the LJ jib. The input value of the sensor is outside the normal range. The normal range is 0.25-4.75 V.	Sensor error. Sensor cable broken or short-circuit. Internal transmitter error.
E2193	Error in the sensor for display of control pressure. The input value of the sensor is outside the normal range. The normal range is 0.25-4.75 V.	Sensor error. Sensor cable broken or short-circuit. Circuit board error.
E2194	Error in the angle sensor of the head section of the fixed jib (FJ, LFJ). The input value of the sensor is outside the normal range. The normal range is 0.25-4.75 V.	Sensor error. Sensor cable broken or short-circuit. Internal transmitter error.

Code	Description	Cause / remedy
E2195	Error in the angle sensor of the head section of the HLJ tip. Input value of the sensor is outside the normal range. The normal range is 0.25-4.75 V	Sensor error. Sensor cable broken or short-circuit. Circuit board error.
E2196	Error in the angle sensor of the head section of the HTLJ tip. Input value of the sensor is outside the normal range. The normal range is 0.25-4.75 V	Sensor error. Sensor cable broken or short-circuit. Circuit board error.
E2198	Error in the dynamometer of the Power System. The input value of the sensor is outside the normal range. The normal range is 0.25-4.75 V.	Sensor error. Sensor cable broken or short-circuit. Internal transmitter error.
E2201	Error in the diagnosis of output DO 1. Error in diagnosis between target state and actual state. The output setting is ON, although it is set by the AML to OFF. <b>Note: A crane movement is not possible.</b>	Short circuit of signal line. Circuit board error.
E2202	Error in the diagnosis of output DO 2. Error in diagnosis between target state and actual state. The output setting is ON, although it is set by the AML to OFF. <b>Note: A crane movement is not possible.</b>	Short circuit of signal line. Circuit board error.
E2209	Error in the diagnosis of output DO 1. Error in diagnosis between target state and actual state. The output setting is OFF, although it is set by the AML to ON.	Loose signal line. Circuit board error. Fuse blown. Power line for AML relay interrupted.
E2210	Error in the diagnosis of output DO 2. Error in diagnosis between target state and actual state. The output setting is OFF, although it is set by the AML to ON.	Loose signal line. Circuit board error. Fuse blown. Power line for AML relay interrupted.

#### System error

"E3---" error codes show AML-internal errors.

If this error type occurs, crane operation will be switched off.

Contact your local service partner.

Code	Description	Cause / remedy
-	Error in the ROM checksum test.	Reload the program and data. Internal AML error.
E3002	Error in the RAM test.	Hardware error owing to external faults. Internal AML error.
E3003	CPU or DMAC address error.	Hardware error owing to external faults.
E3004	Invalid instruction.	Reload the program and data. Internal AML error.
E3005	Undefined exception is called.	
E3006	The voltage for analogue sensors (5 V) provided by the AML lies outside the validity range.	Cable fault. Circuit fault.
E3007	Incorrect setting data in the flash memory.	Hardware error owing to external faults. Internal AML error. <b>Delete error memory. This message remains active until the error log is deleted. Reload the program and data or configure new settings.</b>
E3008	The program(s) for processing the input/output signals is (are) not running correctly.	Hardware error owing to external faults. Internal AML error.
E3009	Error in the backup RAM.	Circuit fault. Replace battery of the backup RAM.

### Error in the display module

"E4---" error codes indicate an error in the display unit.

If an error in this category occurs, the crane operation is stopped.

Please contact your local service partner.

Code	Description	Cause
E4001	Error in the ROM checksum test.	Memory error. Reload the program and data. Circuit fault in the display module.
E4002	Error in the RAM test.	Memory error. Hardware error owing to external faults. Circuit fault in the display module.
E4003	CPU or DMAC address error.	Memory error. Reload the program and data. Hardware error owing to external faults. Circuit fault in the display module.
E4004	Invalid instruction.	
E4005	Undefined exception is called.	
E4010	Timeout when receiving data. No data can be received from the main module.	Cable fault. The main module updates the flash memory. Circuit fault in the display module or the main module.
E4011	Error when receiving data. No data can be received from the main module.	Cable fault. Circuit fault in the display module or the main module.

### Hello Net error

"E5---" error codes show Hello Net errors.

Contact your local service partner.

Code	Description	Cause
E5011	Error receiving data from MTC. Communication with MTC cannot be started. The reception time has been exceeded (data error) and restoration does not take place within the specified time. This message is only displayed for 10 seconds.	Hardware error of MTC. Data error. Break in communication line. Internal AML error.

### 3.6 Other safety devices

	<p><b>! WARNING</b></p>
	<p><b>Non-functioning safety devices!</b>                  Non-functioning safety devices may cause accidents.</p> <p>1. Check the safety devices described below for their flawless functioning before starting work.</p>

#### 3.6.1 Anti-twoblock device

The anti-twoblock device deactivates the bottom block and thus prevents it from hitting the boom head.

In such a case, the hoisting rope may break and the load may fall.

Always wind the "Bottom block upwards" hoisting rope to check the deactivation before working on the crane. You can set the control lever to "Bottom block downwards" to release the bottom block.

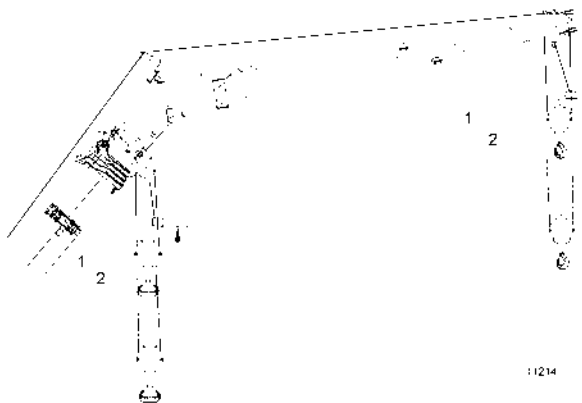

1	Anti-twoblock device	2	Anti-twoblock device weight
---	----------------------	---	-----------------------------



The term "stroke end" refers to a state that prevails before the bottom block comes in contact with the release weight of the anti-twoblock device.

A "stroke end" may be caused by lifting the load up to the release weight of the anti-twoblock device, by lowering or extending the boom without unwinding the hoisting rope.



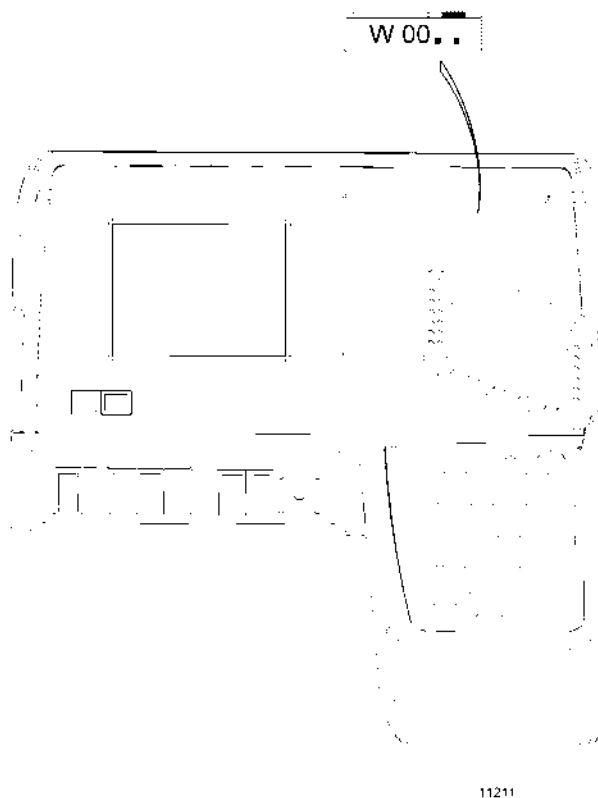



When the bottom block touches the release weight of the anti-two-block device, the lifting operation will be stopped.

An error message will be simultaneously shown on the display of the automatic safe load indicator. Lifting is possible. The error message on the display disappears.

### 3.6.2 Overriding the automatic safe load indicator

	 <b>WARNING</b>
	<p><b>Crane operations with overridden automatic safe load indicator!</b></p> <p>The mobile crane can be overloaded if the automatic safe load indicator is overridden. This may lead to an accident.</p> <ol style="list-style-type: none"> <li>1. Only the authorized personnel may use the override function in emergency cases and when setting up the mobile crane. Immediately bring it back to the normal position.</li> </ol>

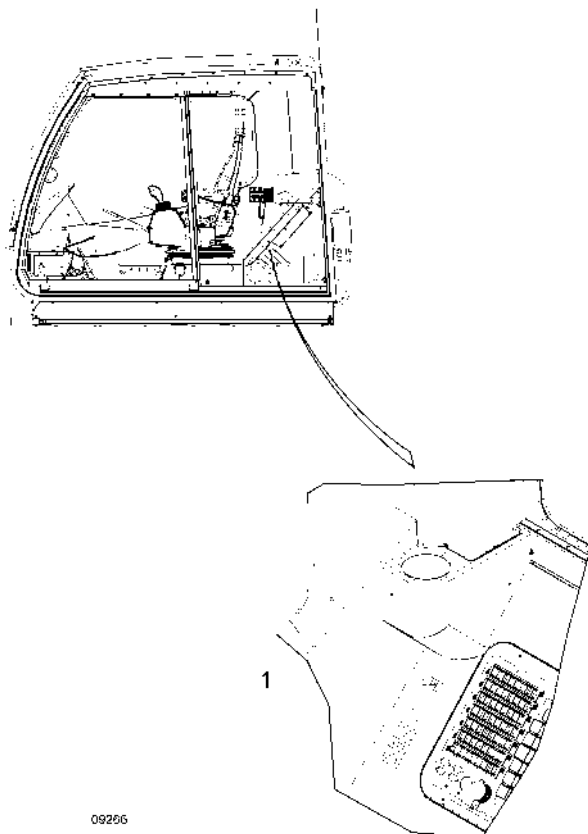

- |   |   |
|---|---|
| 1 | Key-operated switch for "overriding the automatic safe load indicator in the setup program" |
|---|---|

Turn the "automatic safe load indicator override" key-operated switch to the right in order to override the automatic safe load indicator in the setup program, e.g. extend the telescope.

#### 3.6.3 Lower limit switch



#### WARNING

##### **The hoisting rope is wound over the hoisting gear without any load!**

If the hoisting rope is wound over the hoisting gear without any load, the encoder switch that detects the safety rope windings on the winch drum is adjusted. The deactivation then no longer functions without errors. The hoisting rope may be unwound completely and may fall on the ground along with the load. This may cause an accident.

1. If the bottom block is removed, the hoisting rope may be wound only up to the hoisting gear using the rope end.  
⇒ If this happens again, reset the encoder switch.

**WARNING**

**Hoisting gear end switch is not functioning!**

Unwinding of the hoisting rope is not stopped on time. The hoisting rope may break and the load may fall. Risk of accident!

It is also possible that the hoisting rope is wound incorrectly. Winding/unwinding functions are interchanged. There is a risk of accident in this case as well.

1. Always ensure that the hoisting gear end switch functions without any errors.

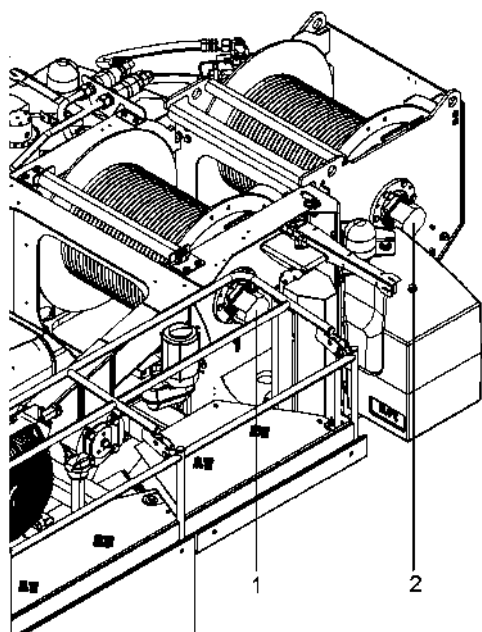

09267

1	Hoisting gear end switch of hoisting gear 1	2	Hoisting gear end switch of hoisting gear 2*)
---	---	---	---

The hoisting gear end switches prevent the complete unwinding of hoisting ropes from the winch drums of hoisting gears 1 and 2\*).

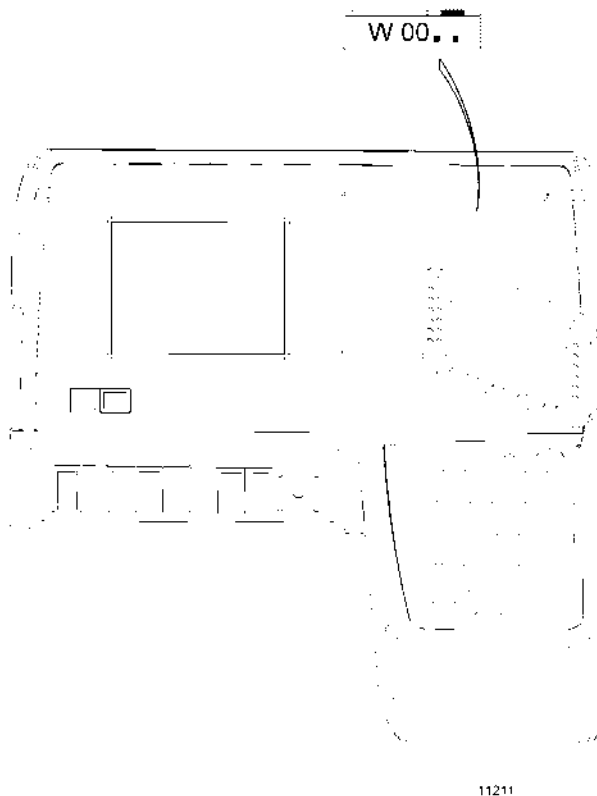

The hoisting gear end switch is released when only three windings of the hoisting rope remain on the winch drum, and the hoisting rope unwinding movement is automatically interrupted.

Only the hoisting rope winding movement is then possible.



An error message will be simultaneously shown on the display of the automatic safe load indicator. The hoisting rope can be wound. The error message on the display disappears.

#### 3.6.4 Anemometer

	 <b>WARNING</b>
	<p><b>Wind speed is too high!</b></p> <p>If crane operations are carried out at unduly high wind speeds, the mobile crane may overturn. This can cause injuries to persons, which could sometime be fatal.</p> <ol style="list-style-type: none"><li>1. Stop the crane operation immediately, retract the boom and lay it down.</li></ol>

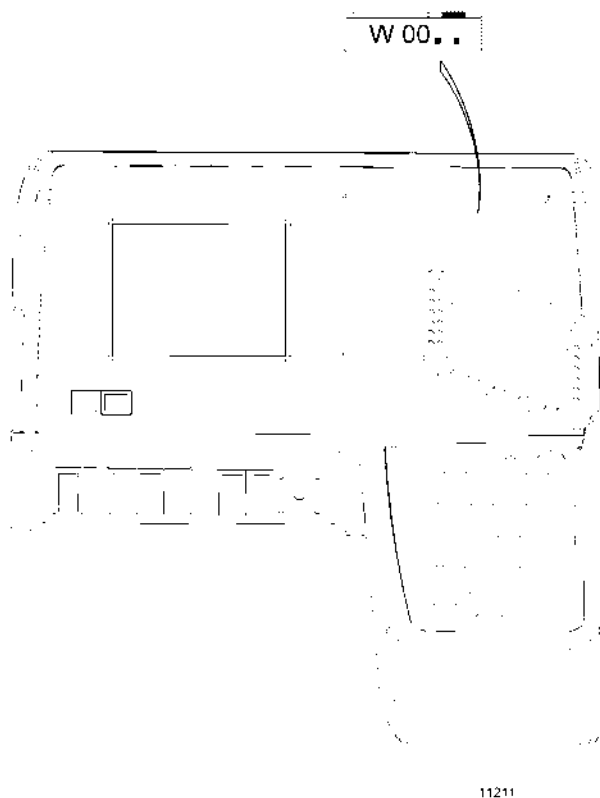

If the rated wind speed value given in the instructions regarding the lifting capacity charts is exceeded, an error message is shown on the automatic safe load indicator display.



### NOTICE

**The anemometer is mounted on the mobile crane when it is driven!**  
The anemometer may get damaged if it remains mounted when driving.

1. The anemometer must be removed when driving.

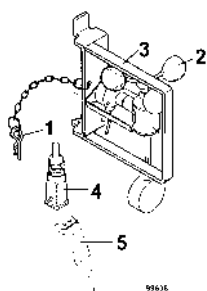

#### Removing the anemometer

1. Remove the plug (5) from the socket (4).
2. Remove the spring clip (1).
3. Remove the anemometer (2) with the retaining device (3).

Install the anemometer logically in the reverse order.

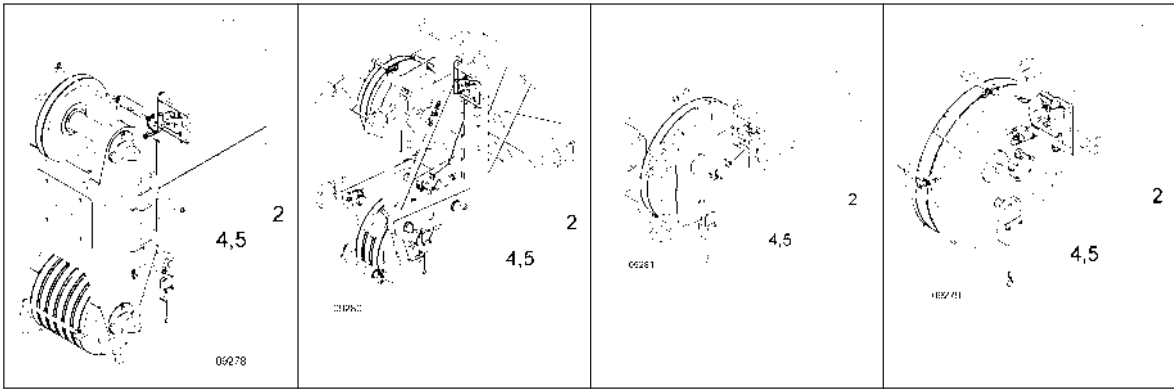

Secure the anemometer to the holder in the cab when the vehicle is being driven.

#### 3.6.5 Aircraft warning lamp\*)

The aircraft warning lamp must be switched on when operating the crane in conformity with the applicable guidelines.

The aircraft warning lamp must be mounted on the boom head and the jib.

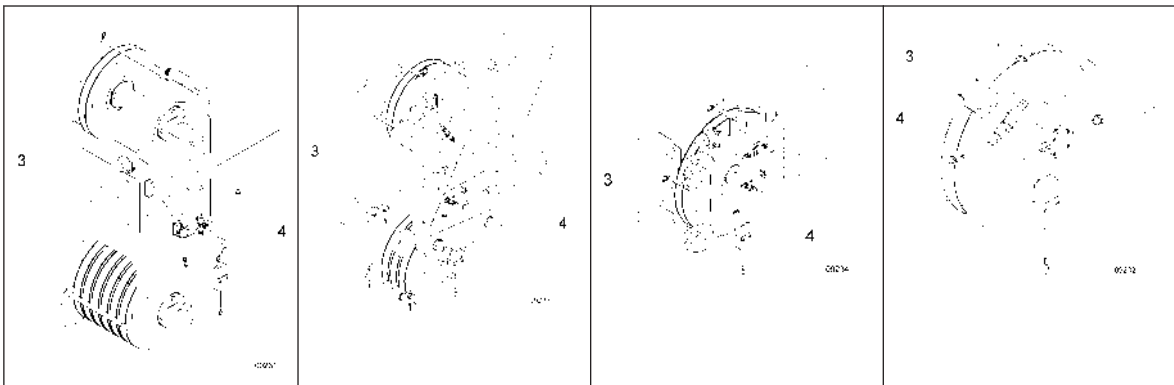

Fix the aircraft warning lamp (3) in the holder and establish the electrical connection (4).





It is detached in the reverse order. Secure the aircraft warning lamp to the holder in the cab when the vehicle is being driven.

### 3.7 Commissioning

#### 3.7.1 Measures and checks before commissioning

	 <b>WARNING</b>
	<p><b>Parking brake not applied when operating the superstructure!</b></p> <p>The mobile crane may go out of control if the outrigger cylinders are retracted from the superstructure. This may cause an accident.</p> <p>1. The parking brake (parking brake lever) in the driver's cab must be applied.</p>

	<p><b>! WARNING</b></p> <p><b>Presence of persons in the driver's cab when operating the superstructure!</b></p> <p>In case of an accident, the load may fall on the driver's cab. Persons in the driver's cab may get injured or die.</p> <ol style="list-style-type: none"> <li>1. No persons may be present in the driver's cab when operating the superstructure.</li> </ol>
	<p><b>NOTICE</b></p> <p><b>Electrical consumers in the carrier are switched on when operating the crane!</b></p> <p>Batteries of the carrier may get discharged.</p> <ol style="list-style-type: none"> <li>1. All current consumers (e.g. inspection lamps, interior lights, radio, etc.) in the carrier must be switched off when operating the superstructure.</li> </ol>

### Measures and checks before commissioning





Before commissioning the superstructure, carry out all essential checks described in the "Commissioning the carrier" chapter.



#### In the carrier:

Switch on the main switch of the battery,

Set the ignition key to position 1,

Set the key-operated switch to position 2 (the connection with the superstructure will be established).

	<p>When the carrier key-operated switch is in position 2, it blocks the axle suspension automatically. The "Axle suspension locking on" symbol must light up.</p>	
	<p>If the symbol does not light up, the suspension is not locked or the axle suspension locking system is defective.</p>	
		<p>The "Axles 1-5" lifted symbol must light up when operating the crane; the "Axles suspended" symbol may not appear when operating the crane.</p>

	 <b>WARNING</b>
	<p>When operating the crane, the symbols "Axles locked" and "Axles lifted" go out and the "Axles suspended" symbol lights up.</p> <p>The mobile crane may become unstable and overturn. This may cause an accident.</p> <p>1. Stop the crane operation immediately, find the cause of the fault and rectify it.</p>

**In the superstructure:**

The boom is retracted and laid in the mast compartment (on-road travel mode).

Switch on the battery main switch in the superstructure.

Do not actuate the "Slewing gear brake" rocker switch.

Insert the ignition key into the ignition starter switch.

**3.7.2 Electrical system**

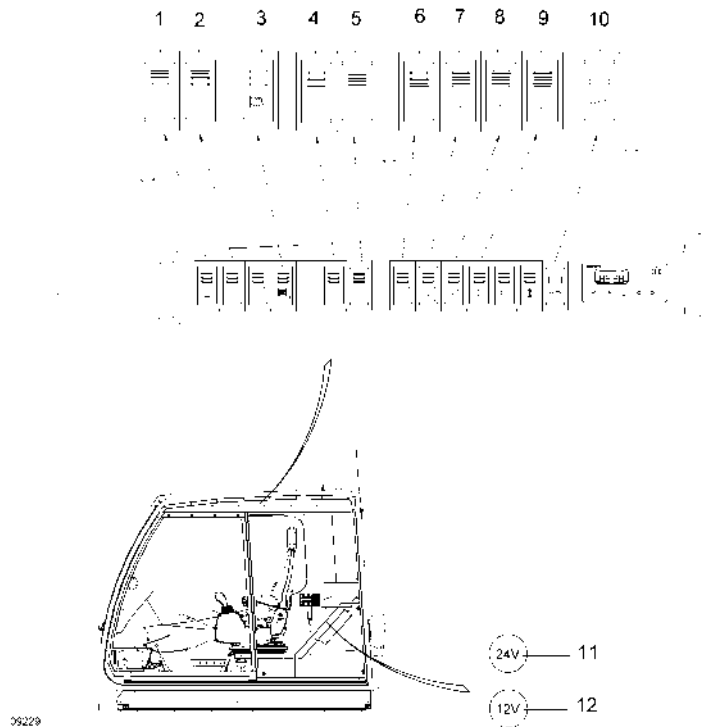

1	Rocker switch for the aircraft warning lamp*)	7	Rocker switch for the roof panel wiper
2	Rocker switch for the mirror heater on the boom	8	Rocker switch for the windshield wiper
3	Rocker switch for working floodlights of hoisting gear	9	Rocker tip switch for windshield washing system
4	Rocker tip switch for motorized working floodlights	10	Battery main switch



5	Rocker switch for working floodlights on the base boom	11	24V socket
6	Rocker switch for instrument illumination/working floodlight in the crane cab	12	12V socket

### Battery main switch

<b>i</b>	Never switch off the battery main switch when the engine is running. The current flow between the generator and the battery may not be interrupted (damage to the generator diodes).
----------	--

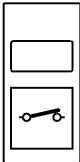
	Switch on: Push the "Battery main switch" rocker switch downwards by actuating the locking handle and then push the rocker tip switch down. The locking handle returns to the stop position automatically.
---	---

Switch off:

Press the locking handle downwards and the rocker switch upwards in order to disconnect the electrical system and de-energize it.

<b>i</b>	Switch off the battery main switch in case of longer intermissions, e.g. overnight.
----------	---

### Working floodlights on the base boom

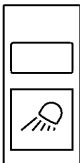
	Switch the working floodlights on/off by pressing the "Working floodlights on the base boom" rocker switch. Rocker switch pressed downwards - switch on. Rocker switch pressed upwards - switch off
---	---

### Working floodlight - electrical adjustment\*)

	Actuate the "Working floodlight" rocker tip switch. The working floodlight on the boom will be adjusted.
---	--

#### Working floodlight on the cab and instrument illumination

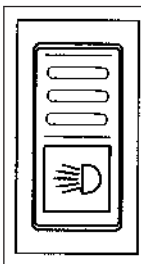

Actuate the "Working floodlight on the cab and instrument illumination" rocker switch:  
 Upper switch position - off,  
 Middle switch position - instrument illumination,  
 Lower switch position - instrument illumination/working floodlight on the crane cab.

#### Aircraft warning lamp\*)



Actuate the "Aircraft warning lamp" rocker switch; the aircraft warning lamp on the boom will be switched on, the green function light in the switch will light up and indicate the switched-on state.



The aircraft warning lamp functions only when the battery main switch is switched on.

#### Windshield wipers

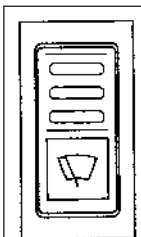

Rocker switch for the "Cab front windshield wipers":  
 Upper position - off,  
 Middle position - intermittent wiper operation,  
 Lower position - wipe.

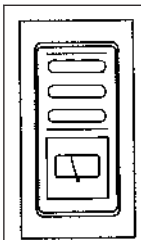

Rocker switch for the "Roof panel windshield wipers":  
 Upper switch position - off,  
 Middle switch position - intermittent wiper operation,  
 Lower switch position - wipe.

#### Windshield washing system

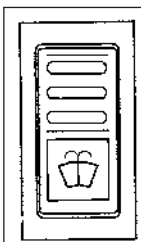

Actuate the "windshield washing system" rocker tip switch. The windshield washing system for the front windshield and roof panel will be actuated. Both windshield wipers operated once.

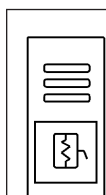
**Working mirror heater\*)**

Press the "Working mirror heater" rocker switch. The green function light in the switch will light up and indicate the heating operation.

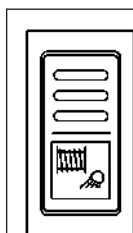
**Working floodlight on the hoisting gear\*)**

Switch the working floodlights on the hoisting gear on/off by pressing the "Working floodlights on the hoisting gear" rocker switch.

Rocker switch pressed downwards - switch on.

Rocker switch pressed upwards - switch off.

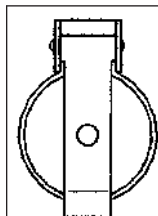
**Plugboxes**

Two plugboxes for 12 V and 24 V DC are provided behind the seat.

External loads can be connected to the plugboxes (e.g. inspection lamp, etc.). Use the adapter unit if necessary.

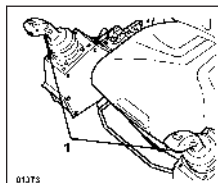
**Signal horn**

The signal horn serves as a warning before beginning the work or when operating the crane, and is actuated using the switch (1).

3.7.3 Starting/stopping the engine

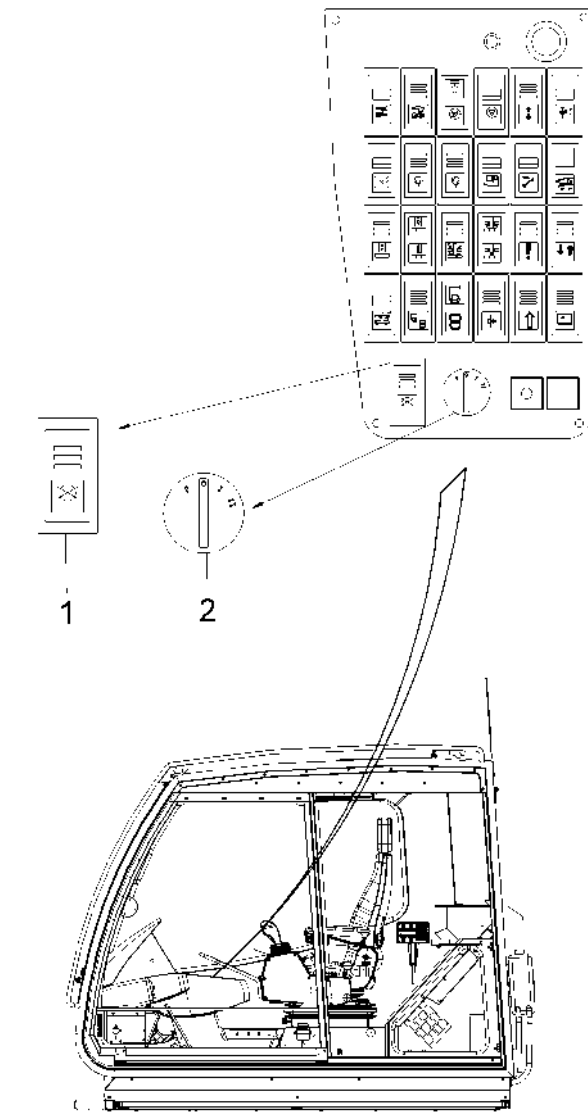

09235

1	2
Rocker tip switch for stopping the engine	Rotary ignition starter switch

Ignition starter switch

	<p>When the ignition key is inserted, the ignition starter switch has the following switch positions:</p> <p>Position P: no function,                  Position 0: ignition off,                  Position I: ignition on,                  Position II: engine start.</p>
--	--

## Switching on the ignition

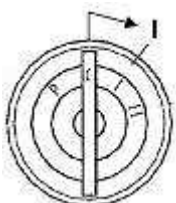
	<p>1. Turn the ignition key to "Position I".</p> <p>The ignition is switched on. The following symbols light up: Symbol: on-board voltage, tank volume, coolant temperature, level, superstructure lock.</p>
---	--

	<p>Wait for at least 10 seconds between switching "Ignition OFF" and re-switching "Ignition ON". Or else it could lead to problems in the vehicle electronics.</p>
---	--

## Starting the engine

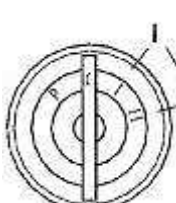
	<p>Turn the ignition key to "Position II" (start) up to the end stop and hold it against the spring force. Release the key as soon as the engine starts; the key goes back to Position I.</p>
---	---

The following instruments are in operation when the engine is running:

hourmeter, Cockpit-Graphic-Control System.

For explanations regarding the pilot lamps and instruments when the engine is running, please refer to "Monitoring the display, indicator and warning lamps as well as the instruments when the engine is running".

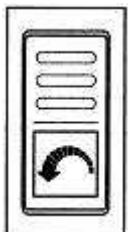
	<p>"Superstructure engine speed regulation" rocker tip switch. Press the rocker tip switch upwards: reduces engine speed. Press the rocker tip switch downwards: increases engine speed.</p>
---	--

	<p><b>NOTICE</b></p>
	<p><b>Starting problems!</b></p> <p>The starter may get damaged if the actuation time is too long.</p> <ol style="list-style-type: none"> <li>1. Do not actuate the starter for more than 20 s.</li> <li>2. If the engine does not start, turn the starter switch back to the "0" position. Wait for at least 60 seconds before re-attempting to start the engine in order to protect the batteries.</li> </ol>



#### **NOTICE**

##### **Engine faults!**

Engine faults can be identified through loud noises or vibrations.

1. Pay attention to the sound or vibrations of the engine after the engine is started.
2. Contact the TADANO After-Sales Service in case of abnormalities.

For other details, refer to the operating manual provided by the engine manufacturer.

#### **Stopping the engine**

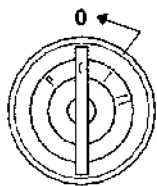
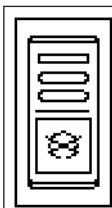

Press the "Engine stop" rocker tip switch until the engine stops.

Turn the ignition key to the left up to position "0". The ignition is switched off.

Remove the ignition key.



Do not stop the engine at an increased speed.

Do not stop the engine immediately after a heavy load, but instead let it continue running at the idling speed for a few minutes in order to balance the temperature.

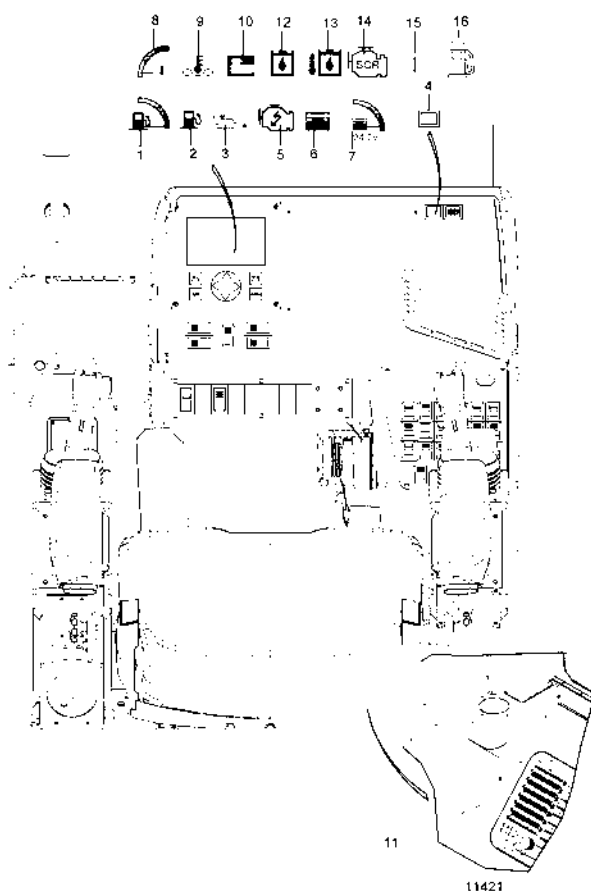

For other details, refer to the operating manual provided by the engine manufacturer.

### 3.7.4 Monitoring the display, indicator and warning lamps as well as the instruments when the engine is running



1	Fuel level indicator symbol	9	Coolant temperature critical range symbol
2	Fuel level symbol	10	Air cleaner contamination symbol
3	Engine oil level symbol	11	Engine hourmeter
4	Warning lamp for the central warning	12	Hydraulic oil filter symbol
5	Engine/engine electronics fault symbol	13	Engine temperature display
6	On-board voltage symbol	14	Exhaust gas treatment icon
7	On-board voltage too low symbol	15	Compressed air supply icon
8	Coolant temperature display symbol	16	AdBlue® fill level icon

#### Fuel level indicator

	 <b>WARNING</b>
	<p><b>Risk of explosion!</b> Inflammable gases may form if the fuel tank is open.</p> <p>1. Smoking and naked fire are not allowed; fill the fuel tank when the engine is stationary.</p>

	Never empty the fuel tank completely. Otherwise, air may enter the fuel system. It is then necessary to bleed the air from the fuel system. Refer to Operation in case of an emergency.
---	---



If the indicator falls close to the 0 display, top up the fuel in time.



The Fuel level symbol also appears.

#### Engine

##### Oil level



The warning lamp for "Central warning" and the "Oil level" symbol light up. Engine oil level is too low.

Stop the crane operation immediately and switch off the engine. Top up the engine oil.

You can restart the engine only after repairing the fault.

For other details, refer to the operating manual provided by the engine manufacturer.

##### Engine function





The central warning lamp and the "Engine/engine electronics fault" symbol light up.

Stop the crane operation immediately and switch off the engine. Find the cause of the fault and rectify it.

You can operate the crane only after repairing the fault.

If required, visit a specialist workshop to repair the fault.

#### Generator

	 <b>WARNING</b>
	<p><b>The batteries are not charged.</b></p> <p>The mobile crane can breakdown due to insufficient power supply. This may cause an accident.</p> <ol style="list-style-type: none"> <li>1. Get the error repaired in a specialist workshop as soon as possible.</li> <li>2. Always ensure that the batteries are fully charged.</li> </ol>



As soon as the engine starts running, the "Generator" symbol must disappear and should not light up again during operation. The "On-board voltage too low" symbol and the warning lamp for "Central warning" should not light up during operation,

If this is the case, there is a fault and the batteries are not charged.



The warning lamp for "Central warning" and the "On-board voltage too low" symbol should not light up during operation,

If this is the case, there is a fault and the batteries are not charged.



### Coolant temperature



The coolant temperature is monitored by the warning lamp for "Central warning", the "Coolant temperature display" symbol and the "Coolant level" symbol. The permissible operating temperature is between 80 °C (176 °F) and a maximum of 95 °C (203 °F).

If the coolant temperature exceeds the maximum permissible temperature, the "Coolant temperature critical range" symbol also lights up.

For specifications regarding the remedy in case of excess temperature, please refer to the operating manual provided by the engine manufacturer.

### Air cleaner contamination



The air cleaner is monitored using the warning lamp for the "Central warning" and the "Air cleaner contaminated" symbol.

Change the air cleaner cartridge if this symbol and the warning lamp light up when the engine is running.

### Operating hours



An hourmeter is used for monitoring the operating hours of the engine. The hourmeter starts working as soon as the engine starts.

### Hydraulic system

#### Hydraulic oil filter contamination



The degree of contamination of the hydraulic oil filter is monitored. The warning lamp for the "Central warning" and the "Hydraulic oil filter" symbol light up if the hydraulic oil filter is excessively contaminated.

In such a case, check the hydraulic oil filter immediately or replace it if required.

#### Hydraulic oil temperature





The hydraulic oil temperature is monitored. The warning lamp for the "Central warning" and the "Hydraulic oil filter" symbol light up at oil temperatures greater than approximately 80 °C (176 °F). In such a case, the crane operation must be stopped.



Before beginning the crane operation, the hydraulic oil temperature must be at least +30 °C (86 °F).

#### Warning lamp for the central warning



	 <b>CAUTION</b>
	<p><b>The warning lamp for the central warning is ignored.</b>          If the warning lamp for the "Central warning" is ignored, it may lead to damage to the engine.</p> <ol style="list-style-type: none"> <li>1. If the warning lamp for the Central warning lights up, determine the cause of the fault and rectify it immediately.</li> </ol>



The warning lamp for the "Central warning" lights up simultaneously when a symbol for engine fault (error display) appears.

If also lights up as long as a fault or a failure occurs in the CMV monitor.

#### Exhaust gas treatment

	 <b>DANGER</b>
	<p><b>Risk of accidents due to malfunction in the SCR system!</b>          When a malfunction of the SCR system persists for a certain period of time, it will cause a permanent reduction of the engine output and the engine speed. This may result in accidents during driving and crane operation.          This permanent reduction can only be eliminated by the engine manufacturer's specialist staff.</p> <ol style="list-style-type: none"> <li>1. Top up AdBlue® tank in time.</li> <li>2. Switch heating for AdBlue® ON in time at temperatures below freezing point.</li> <li>3. In case of malfunction of the SCR system, shut engine OFF as soon as possible.</li> <li>4. Make sure the engine is not restarted before the malfunction of the SCR system has been eliminated.</li> </ol>

Malfunction in the SCR system may be due to the following reasons:

- AdBlue® tank is empty or AdBlue® is frozen.
- AdBlue® has been heated to more than 60°C (140 °F) and is thus useless.
- AdBlue® is contaminated or of poor quality.
- Malfunction in SCR system.

If there is a malfunction in the SCR system, the indicator lamps *Torque Limiter Active (LIM)*, *Check Engine Lamp (CEL)* or *Fill level and quality monitoring of AdBlue® (DEF)* go on.

If the operator disregards these indicators, a reduction of the engine performance and the engine speed will be activated after a certain period of time. This reduction can be bypassed by the operator up to three times by pressing the switch *Override torque*.

Subsequently, this reduction is effective permanently. It can only be eliminated by the engine manufacturer's specialist staff.

**Compressed air supply icon**

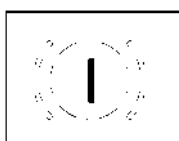

"Compressed air supply" icon lights up when there is a fault in the compressed air system.

Exhaust gas treatment is not functioning.

Have the error fixed as soon as possible in a specialist workshop.

**AdBlue® fill level icon**

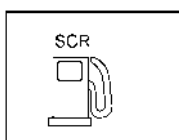

The icon flashes if the fill level is too low.

	<p><b>NOTICE</b></p>
<p>Caution when refueling. Can be corrosive for some metals if they come into contact with AdBlue®. Drops must be wiped away immediately.</p>	

**3.7.5 Central lubricating system**

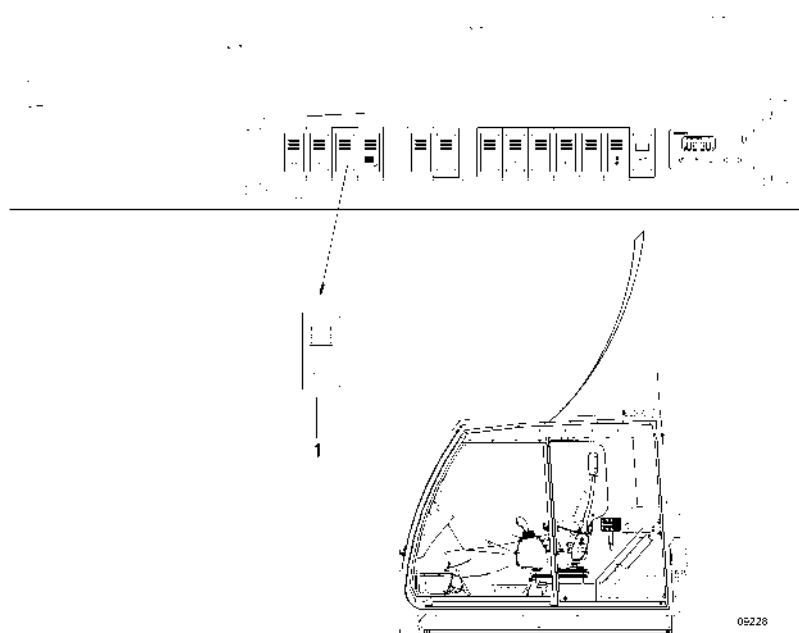

1	Rocker switch for the central lubricating system		
---	--	--	--

The superstructure is equipped with a central grease lubricating system. Only the lubricating points that are not connected must be manually supplied with lubricant.

For instructions regarding the operation and the specifications for lubricating points, please refer to the documents of the device manufacturer.

#### Function

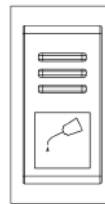

	<p>Press the "Central lubricating system" rocker switch. Grease is supplied to lubricating points. A green pilot lamp in the switch lights up to indicate that the central lubricating system is switched on. The lubricating process is stopped by switching off the rocker switch. The pilot lamp in the switch then goes out. The lubrication duration (contact period) and the duration of regular lubricating intervals depend on the frequency of work movements and can be determined by the operator. Intervals are also recommended in the maintenance schedule.</p>
---	---

Monitor the agitator for checking the function of the central lubricating system. The agitator must rotate. If the agitator does not rotate, there is a fault and grease will not be supplied to the lubricating points of the central lubricating system.

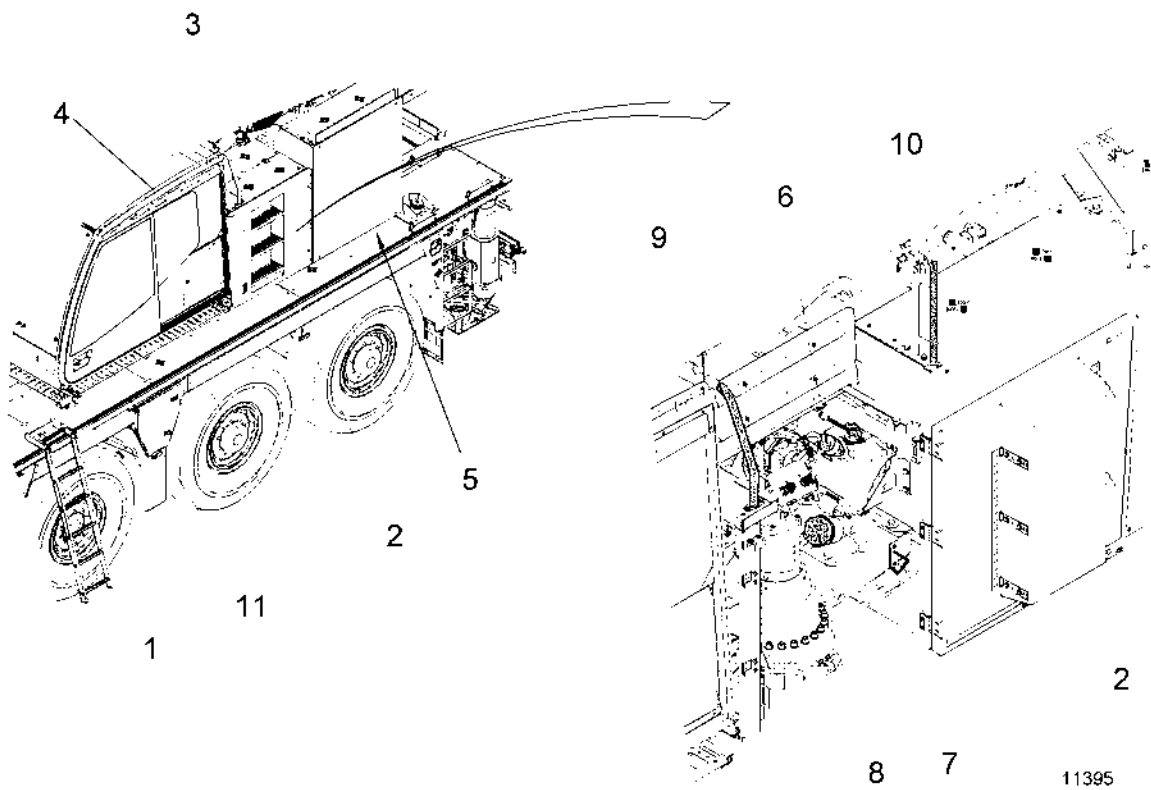
#### 3.7.6 Filling up with diesel or AdBlue®



1	Front climbing aid	7	Holder for pump nozzle
2	Maintenance flap	8	Diesel tank
3	Top maintenance flap	9	Grab handle
4	Superstructure cab grab handle	10	Railing
5	Holder	11	Step tread
6	AdBlue® tank		

	<p style="text-align: center;"><b>⚠ DANGER</b></p> <p><b>Fire risk.</b>  <b>Diesel is flammable.</b></p> <ol style="list-style-type: none"> <li>1. Smoking is prohibited.</li> <li>2. No naked flames allowed.</li> </ol>
	<p style="text-align: center;"><b>⚠ CAUTION</b></p> <p><b>Health hazard.</b>  <b>Diesel and AdBlue® are harmful to health.</b></p> <ol style="list-style-type: none"> <li>1. Do not inhale the fumes.</li> <li>2. Do not swallow.</li> <li>3. Avoid contact with skin and eyes.</li> <li>4. In the event of swallowing, visit your GP immediately.</li> <li>5. Observe other safety instructions of the engine supplier.</li> </ol>
<p style="font-size: 2em; font-weight: bold;">i</p>	<p><b>Damage to the engine due to incorrect fuel.</b>  Only use the fuel that is permitted by the engine manufacturer.</p>
<p style="font-size: 2em; font-weight: bold;">i</p>	<p><b>Damage to exhaust gas aftertreatment.</b>  The exhaust gas aftertreatment system may be damaged if you:</p> <ol style="list-style-type: none"> <li>1. Fill the AdBlue®/DEF tank with cleaning agent or other operating fluid or fuel.</li> <li>2. Add additives.</li> <li>3. Dilute AdBlue®/DEF.</li> </ol> <p>⇒ Observe other instructions of the engine supplier.</p>

### Requirements

When filling up the superstructure with diesel or AdBlue®, the following requirements must be met:

- The superstructure must be supported properly or parking brake engaged.
- The superstructure must be slewed to the front.
- Engines in the superstructure and chassis must be switched off.
- The rear climbing aid must be folded down.
- Step tread must be extended.
- Maintenance flap must be open and secured with the holder.
- Diesel or AdBlue pump nozzle must be mounted on the pump nozzle holder.

### Filling up

1. Access the chassis using the front climbing aid.



 **DANGER**

**Risk of falling due to narrow space available.**

1. Hold onto the grab handle on the superstructure cab.
2. Go to the fuel nozzle, holding onto the grab handle on the superstructure cab while doing so. Use the step tread.
3. Open the fuel cap on the diesel or AdBlue® tank.
4. Take the pump nozzle off the holder. Fill up the diesel or AdBlue® tank. Hold onto the grab handle or the railing while filling up.

#### Finishing fuelling

1. Hang the pump nozzle on the holder.
2. Close the fuel cap on the diesel or AdBlue® tank.



 **DANGER**

**Risk of falling due to narrow space available.**

1. Hold onto the grab handle on the superstructure cab.
3. Go to the climbing aid, holding onto the grab handle on the superstructure cab while doing so. Use the step tread.
4. Pull in the step tread.
5. Leave the chassis, using the front climbing aid.

#### Finishing work

1. Fold up the front climbing aid.



Wipe up any diesel spillages. Wash off any AdBlue® spillages with water immediately – risk of corrosion!

2. Remove the pump nozzle from the holder.
3. Close the maintenance flap before releasing the holder.

## 3.8 Outrigger

### 3.8.1 Preparations

In the carrier

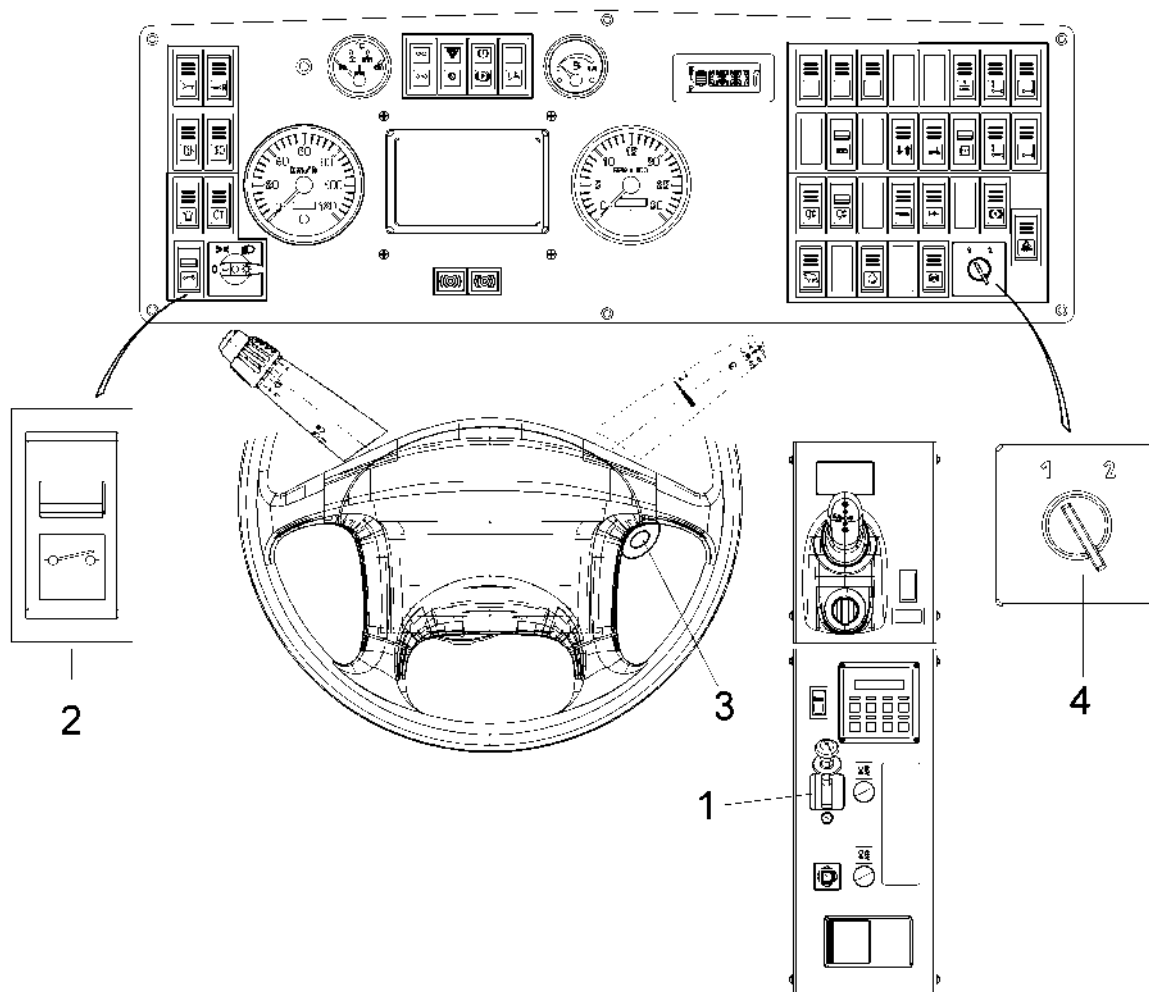

09295

1	Parking brake	3	Ignition lock
2	Battery main switch	4	Key-operated toggle switch

The parking brake in the carrier is not applied.

The battery main switch in the carrier must be switched on.

The ignition key in the carrier must be at Position 1.

Change the key-operated toggle switch in the carrier from Position 1 to Position 2.

**i**

The carrier engine cannot be stopped from the superstructure if the ignition in the carrier has been switched on (the ignition key in the ignition starter switch must be in Position 1).

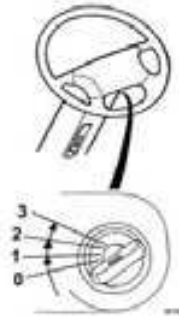

Position 1: superstructure operation, steering wheel lock is open

#### In the superstructure

Take measures and carry out checks as described in the "Commissioning" chapter.

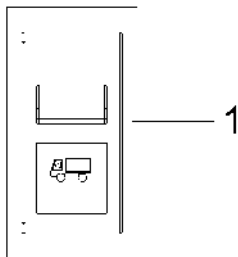
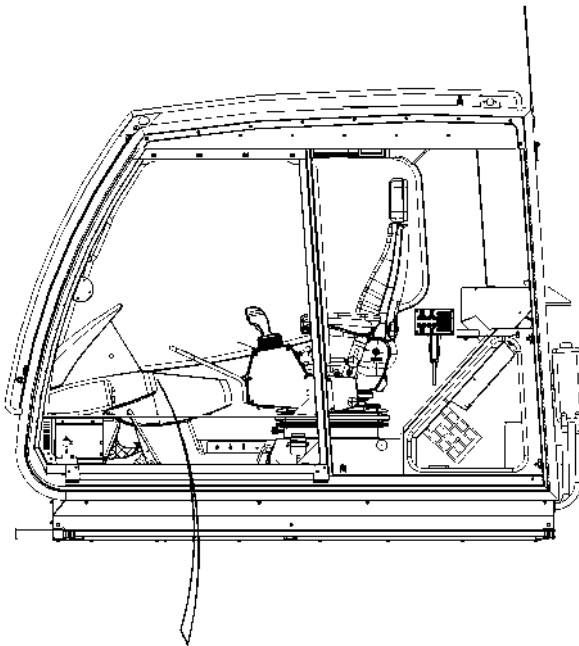

09294

1 Rocker switch for the carrier ignition



Switch position of the key-operated toggle switch in the carrier	Switch position of the rocker switch "Carrier ignition on" in the superstructure	Functions
2	Stop	Ignition in the carrier off = Only superstructure can be operated
2	On	Ignition in the carrier on = The carrier engine can be started from the superstructure, outrigging is possible from the superstructure



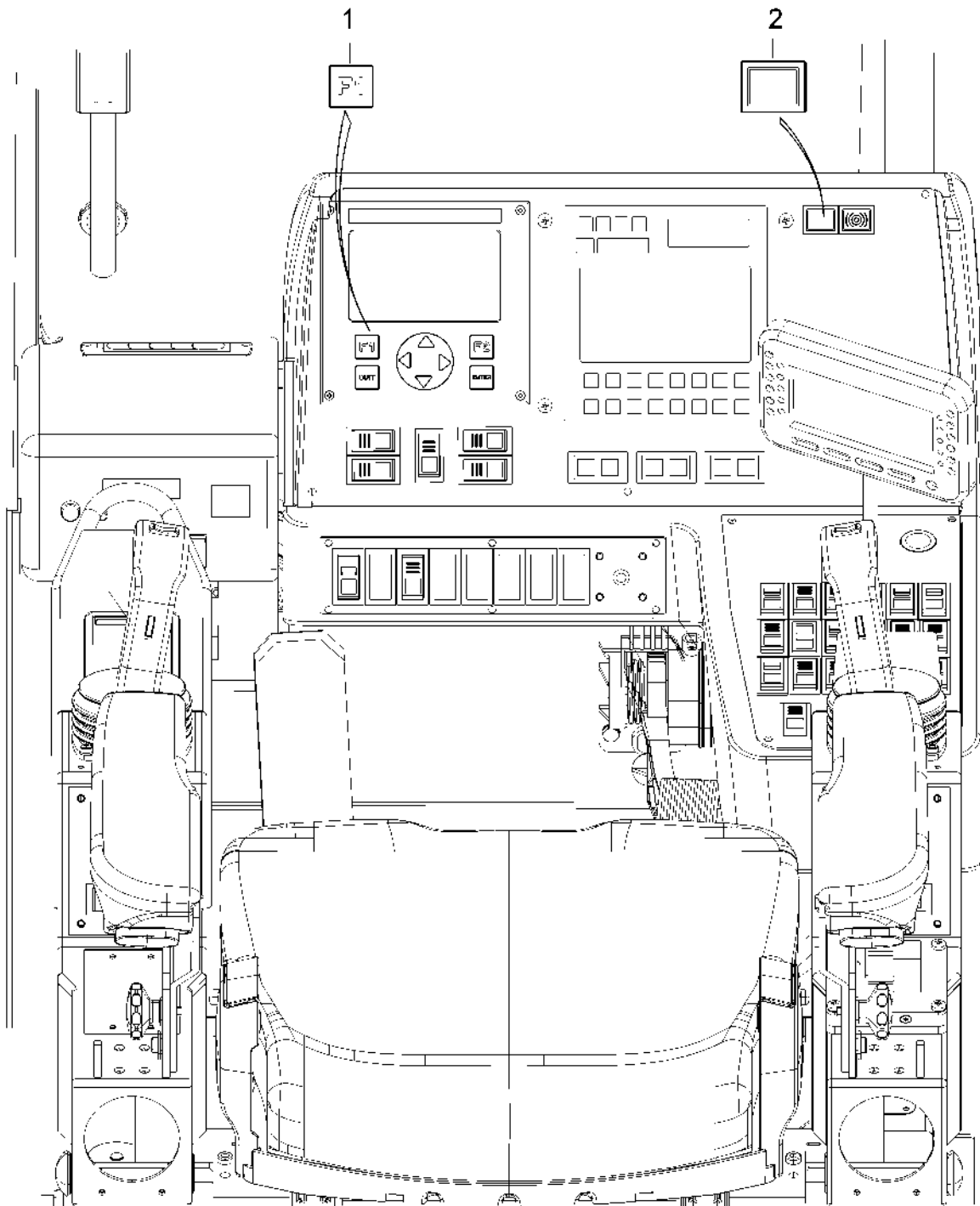

Switch on the "Carrier engine on" rocker switch (the function lamp in the rocker switch will light up). The ignition in the carrier has been switched on, the carrier engine can be started from the superstructure and outrigging is possible from the superstructure.

## Starting the carrier engine



09296

1 Carrier engine start switch	2 Warning lamp for the CGC Central Warning
-------------------------------	--

 A square button with the text "F1" in the center.	Press the F1 "Carrier engine start" switch until the engine starts. Actuation time of the starter is not longer than 20 seconds.
 A square warning lamp icon with a thick border.	After starting, the red warning lamp for the "CGC central warning" goes out.

#### Engine speed regulation

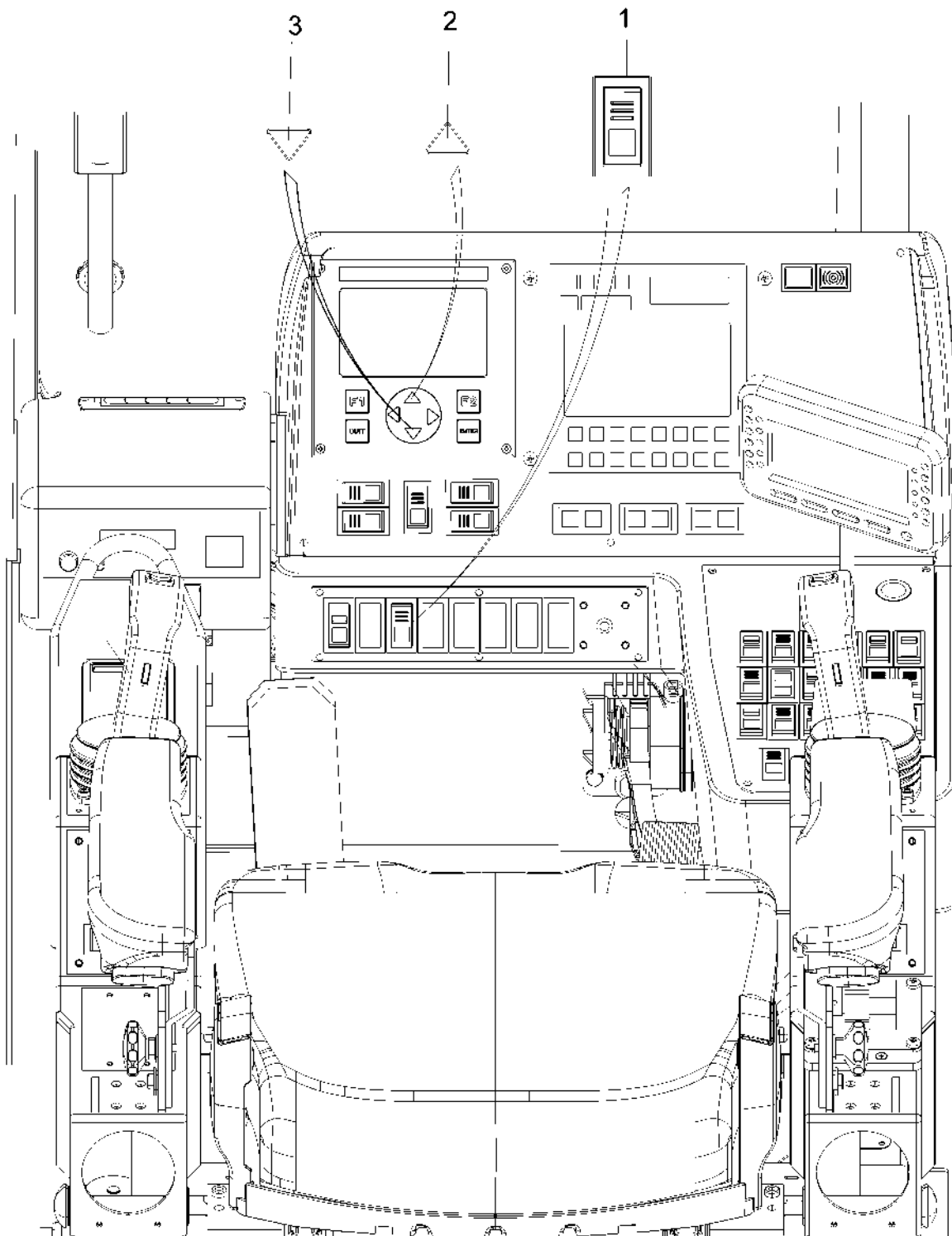

09297

1	Rocker tip switch for engine speed regulation	3	Reduce engine speed arrow key
2	Increase engine speed arrow key		

	Actuate the "Engine speed regulation" rocker tip switch. The speed of the carrier engine can be adjusted infinitely.
▲	Press the arrow key upwards = the speed of the carrier engine will be increased.
▼	Press the arrow key downwards = the speed of the carrier engine will be decreased

#### Stopping the carrier engine

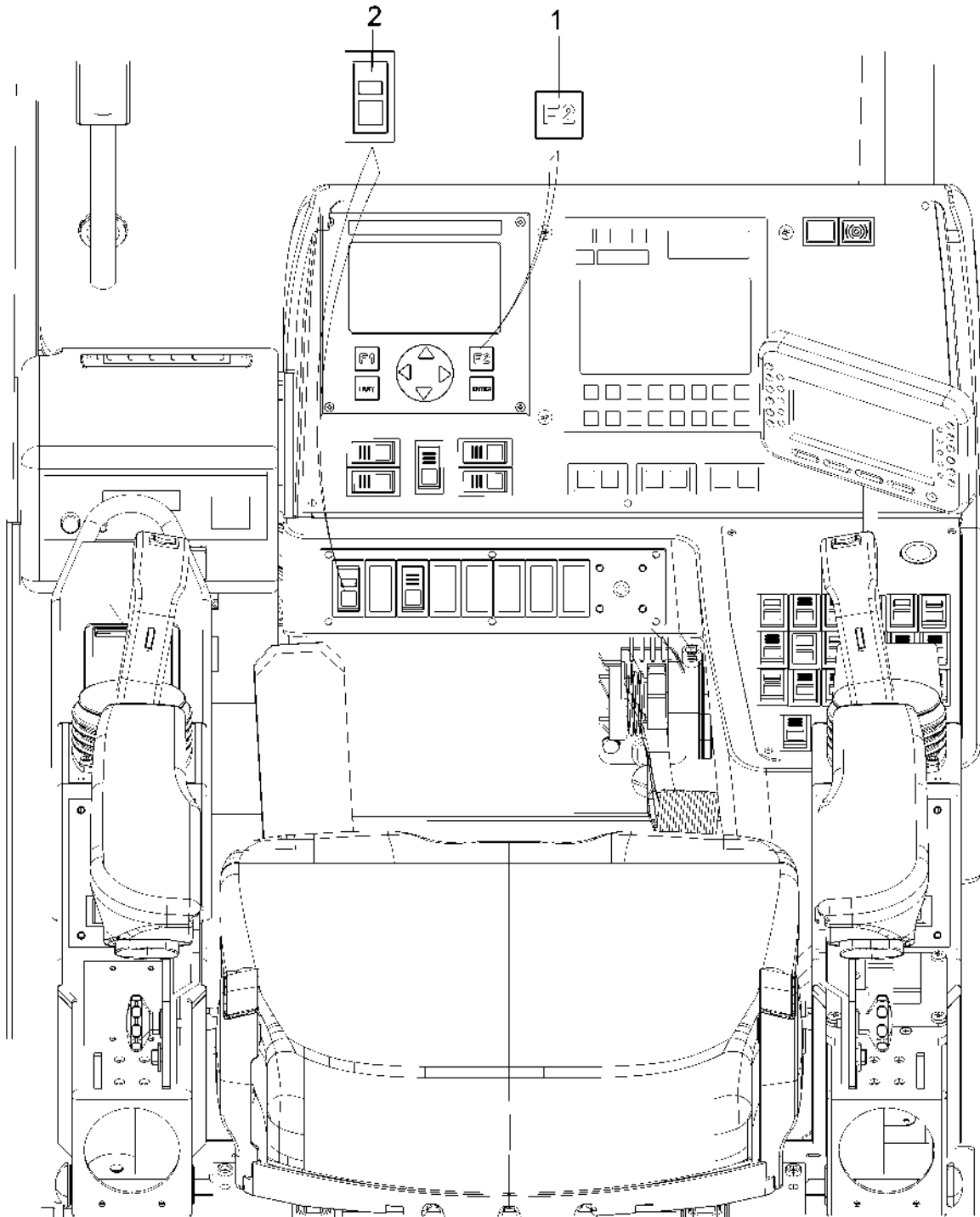

09298

1	Rocker switch for the carrier ignition	2	Carrier engine stop switch
---	--	---	----------------------------

Bring the engine to the idling speed.

	Press the F2 "Carrier engine stop" switch until the carrier engine stops.
---	---

or



Switch off the "Carrier ignition" rocker switch to stop the engine.



After switching off the carrier engine from the superstructure, always switch off the "Carrier ignition" rocker switch, otherwise the carrier batteries will discharge.

3.8.2 Outrigger

Alarm displays

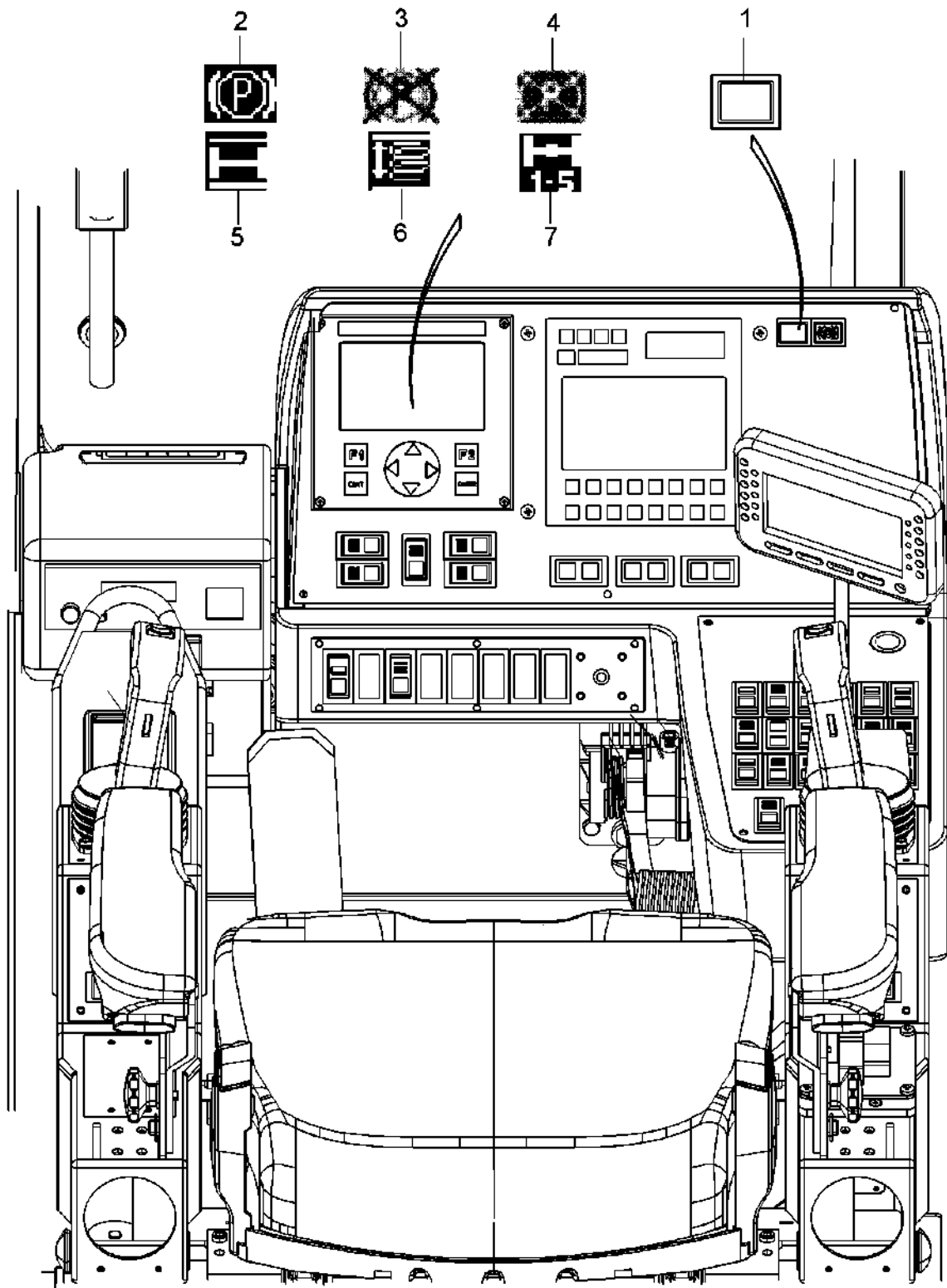

09301



1	Warning lamp for the CGC Central Warning	5	Axle suspension locking symbol
2	Parking brake applied symbol	6	Axles locked symbol
3	Parking brake not applied symbol	7	Axles lifted symbol
4	Parking brake not applied symbol - inverse		



## CGC central warning

	The warning lamp for the "Central warning" appears in case of electronic errors in the control, carrier CAN-Bus errors, sensor errors as well as function errors in the superstructure and the carrier engine.
---	--

Pay attention to the warning lamp for the "Central warning". If it lights up, determine the cause of the fault and rectify it immediately.

## Carrier parking brake

	The "Carrier parking brake applied" symbol lights up when the parking brake in the carrier is applied or when the supply pressure of the parking brake in the carrier is not adequate.
---	--

		The "Carrier parking brake not applied" symbol appears and flashes if the parking brake in the carrier is not in the brake position.
---	---	--

## Axle suspension locking

	When toggling the key-operated toggle switch in the carrier, the axle suspension locking is changed from Position 1 to Position 2. The "Axle suspension locking" symbol must light up during the crane operation.
--	--

	If the "Axles locked" symbol goes out and the "Axles suspended" symbol lights up during the crane operation, stop it immediately, determine the cause of the fault and repair it.
---	---

## Axles lifted

	The "Axles lifted" symbol must light up during the entire superstructure operation.
---	---

The crane may be operated only when the axles are lifted. If the "Axles lifted" symbol goes out during the crane operation, stop it immediately, determine the cause of the fault and repair it.

## Preparations

Follow the instructions regarding the outrigging process given in chapter "Outrigging the mobile crane".

Change the outrigger plates and pin the extended and retracted outrigger beams in the carrier as described in chapter "Outrigging the mobile crane".

Start the carrier engine from the superstructure and let it run a medium speed.

Trigger a warning signal (press the horn) before actuating the outrigger.



#### **WARNING**

##### **Risk of accidents when extending the outriggers!**

If the operator cannot see the outrigger area, people who are present in this area may get injured.

1. Evacuate people from the outrigger area of outriggers.
2. Press the outriggers (extending and retracting) only when the operator or another person can see the outrigger area for the duration of the outrigger process.

Outrigger control using the CG

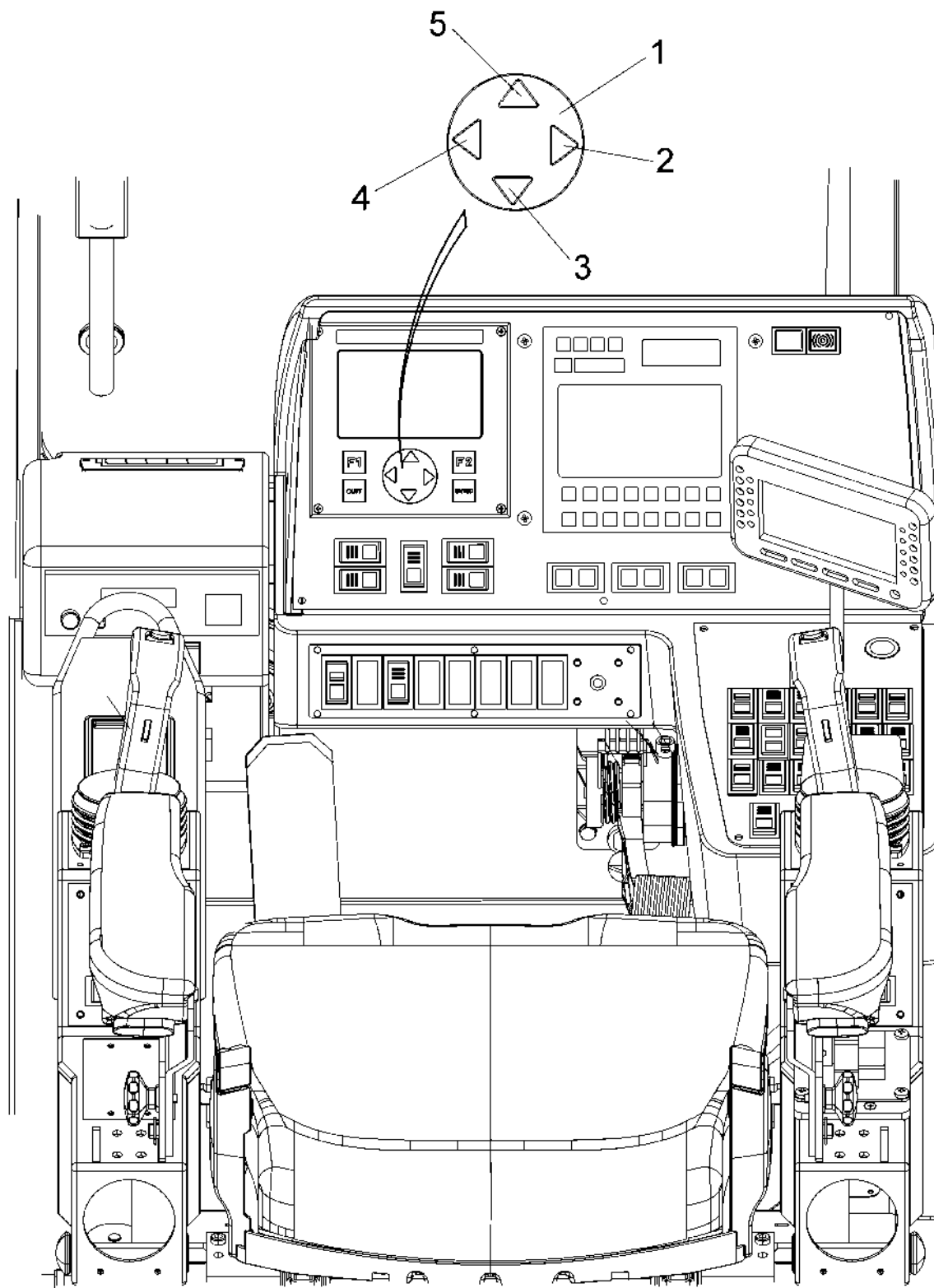

09323

1 Cursor control	4 Front-left outrigger
------------------	------------------------

2	Rear-right outrigger	5	Front-right outrigger
3	Rear-left outrigger		

The outrigger is controlled from the superstructure using the Cockpit-Graphic-Control System. Use the cursor control (arrow keys) to select the outrigger cylinders and outrigger beams.

#### Extending the outrigger beams

Changing and pinning the outrigger plates.

Support the provided outrigger plate bases extensively and stably.

Remove the lock pins from the four outrigger beams as described in the "Outrigging the mobile crane" chapter in the operating manual of the carrier.

Select the desired outrigger beams using the arrow keys.

Press the ENTER key to confirm the selection. Switch to the corresponding screen.

Use the arrow keys to extend the selected outrigger beams up to the required outrigger base and pin them.

Select all the four outrigger beams as described above, extend them to the required outrigger base and pin them.

#### Extending the outrigger cylinders

Follow the instructions given in the "Outrigging the mobile crane" chapter in the operating manual of the carrier.

Use the arrow keys or the F1 key to select the desired outrigger cylinders.

Press the ENTER key to confirm the selection. Switch to the corresponding screen.

Use the arrow keys to extend the selected outrigger cylinders.

Lift the mobile crane only until all tires of the are just lifted from the ground. Do not support the wheels.

Place the mobile crane in the horizontal position (following the electronic spirit level). The marking must be at the centre of the crosshair.

Stop the carrier engine.

#### Retracting the outriggers

Retract the outrigger cylinders/beams in the logical reverse order.

## Outrigger control using rocker tip switches and rocker switches

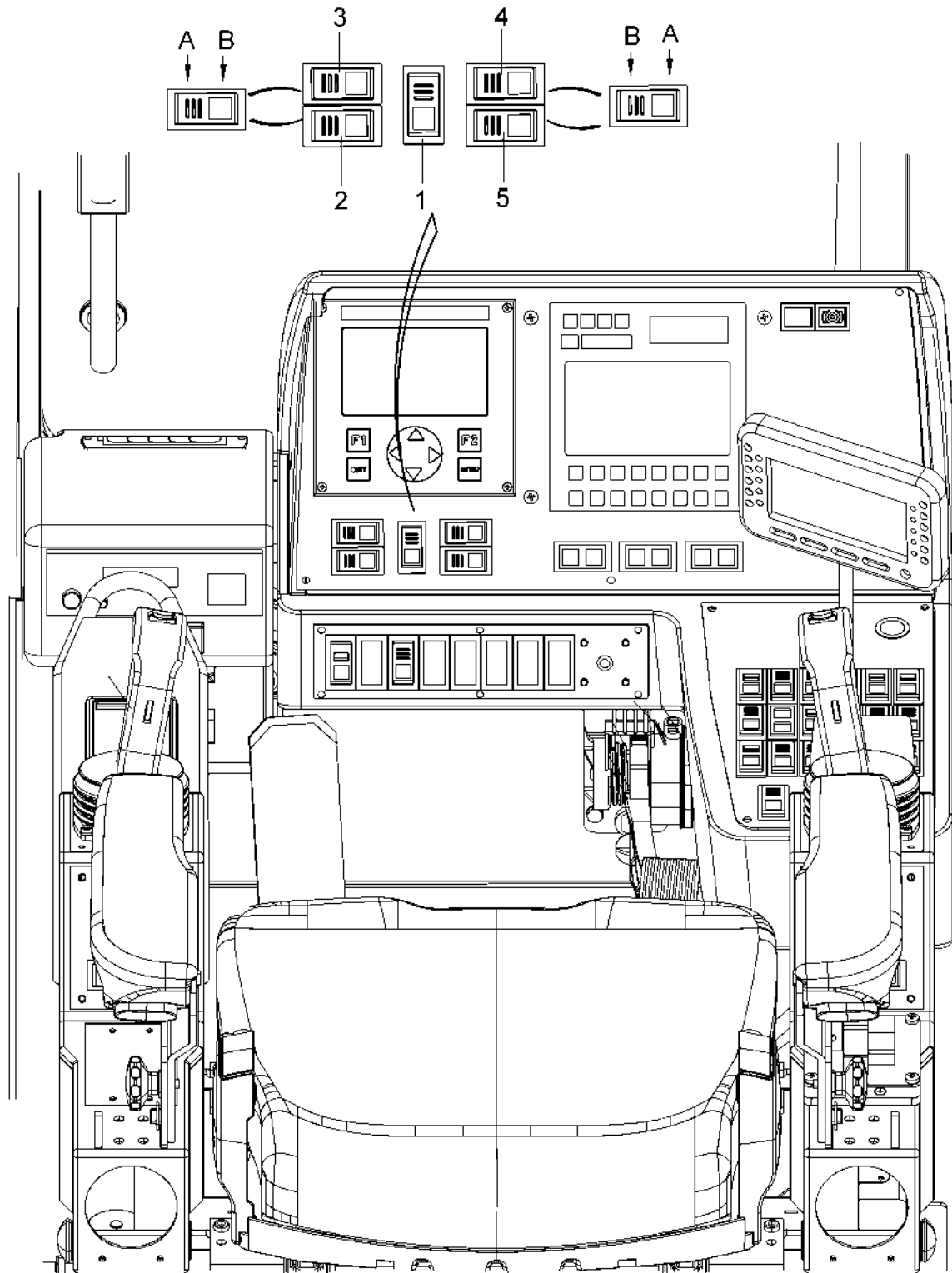

09326

1	Rocker switch for preselecting the outrigger/outrigger cylinder	5	Rocker tip switch for extending/retracting the rear-right outrigger beam/outrigger cylinder
2	Rocker tip switch for extending/retracting the rear-left outrigger beam/outrigger cylinder	A	Extend the outrigger beam/outrigger cylinder
3	Rocker tip switch for extending/retracting the front-left outrigger beam/outrigger cylinder	B	Retracting the outrigger beams/outrigger cylinders
4	Rocker tip switch for extending/retracting the front-right outrigger beam/outrigger cylinder		

Switch positions of the rocker switch for preselecting the outrigger/outrigger cylinder:

Press the rocker switch upwards = pre-selection of the outrigger beam actuation.

Press the rocker switch downwards = pre-selection of the outrigger cylinder actuation.

#### Extending the outrigger beams

Change and pin the outrigger plates as described in the "Outrigging the mobile crane" chapter in the operating manual of the carrier.

Support the provided outrigger plate bases extensively and stably.

Remove the lock pins from the four outrigger beams as described in the "Outrigging the mobile crane" chapter.

Press the "Outrigger pre-selection" rocker switch upwards. Outrigger beams are selected. The outrigger beams can be extended or retracted only individually.

Press the "Extend/retract the rear-left or front-left outrigger beam/outrigger cylinder" rocker tip switch to the left and keep it pressed until the left outrigger beams are extended.

Press the "Extend/retract the rear-right or front-right outrigger beam/outrigger cylinder" rocker tip switch to the right and keep it pressed until the left outrigger beams are extended.

Set the "Outrigger pre-selection" rocker switch to the middle position

Pin the extended outrigger beams.

#### Extending the outrigger cylinders

Follow the instructions given in the "Outrigging the mobile crane" chapter in the operating manual of the carrier.

Press the "Outrigger pre-selection" rocker switch downwards. Outrigger cylinders are selected.

Press the "Extend/retract the rear-left or front-left outrigger beam/outrigger cylinder" rocker tip switch to the left and keep it pressed until the left outrigger cylinders are extended.

Press the "Extend/retract the rear-right or front-right outrigger beam/outrigger cylinder" rocker tip switch to the right and keep it pressed until the left outrigger cylinders are extended.

Lift the mobile crane only until all tires of the are just lifted from the ground. Do not support the wheels.

Place the mobile crane in the horizontal position. The marking must be at the centre of the cross-hair.

Set the "Outrigger pre-selection" rocker switch to the middle position.



Stop the carrier engine.

## Retracting the outriggers

Retract the outrigger cylinders/beams in the logical reverse order.

## 3.9 Functions of control levers and pedals

### 3.9.1 Instructions for actuating the crane control levers

	 <b>WARNING</b>
	<p><b>Crane control lever improperly actuated.</b> Very fast lifting, derricking, turning and braking movements can lead to the load swinging.</p> <ol style="list-style-type: none"> <li>1. The larger the load or the greater the boom length, the more careful the movements should be.</li> <li>2. Execute the crane work with utmost care.</li> </ol>

The actuation of the crane control lever described below corresponds to the standard model. Special models deviating from this have not been taken into account.

Operating shields affixed in the crane cab are always binding for the crane operator.

The speed of work movements is controlled through the sensitive actuation of crane control levers and by changing the engine speed.

All crane movements can be initiated independent of each other. One or both crane control levers can be slewed in longitudinally, laterally or diagonally.

The finest control of crane movements is possible even at the engine idling speed.

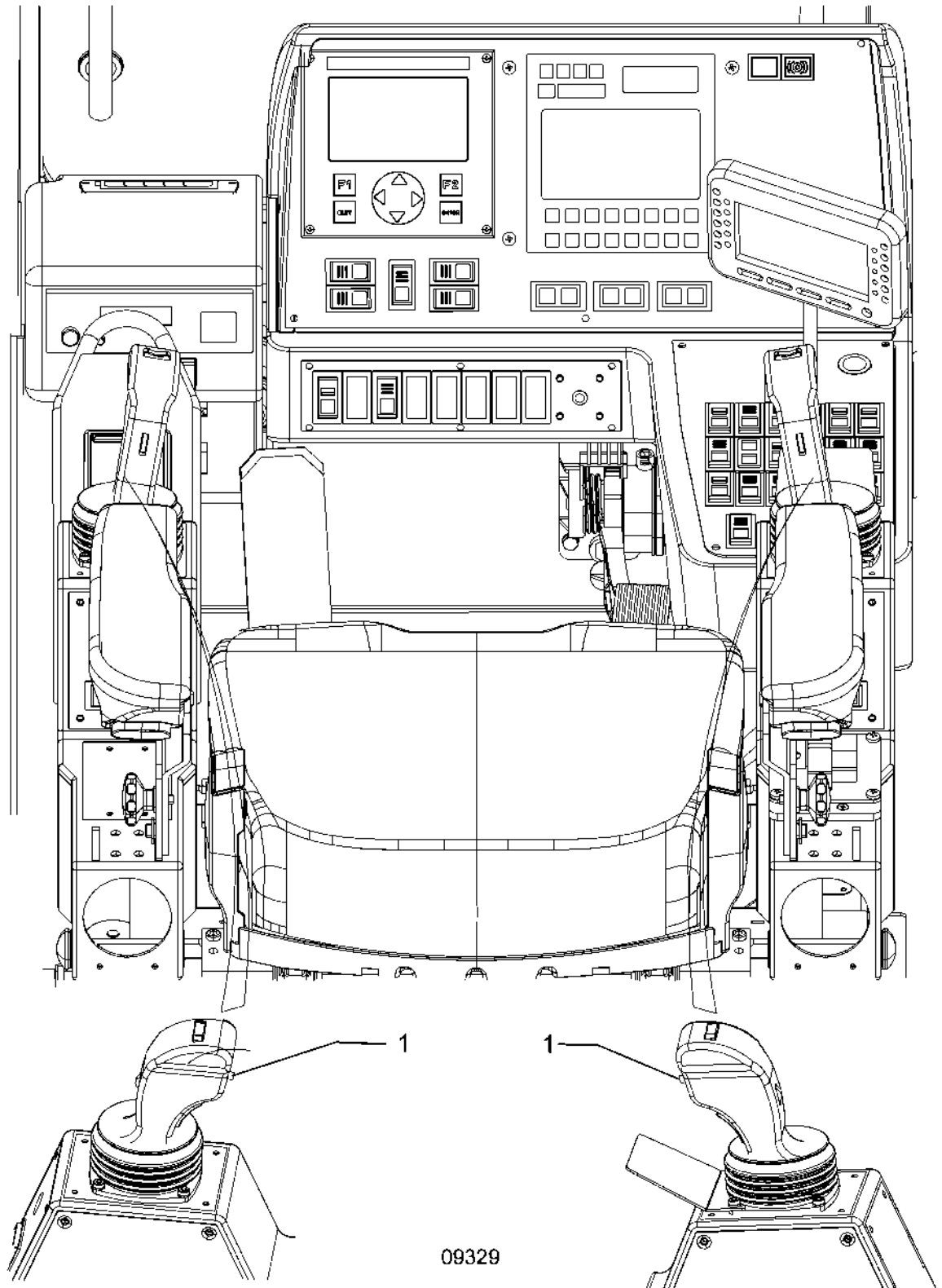

Movements of the crane when it is overloaded and/or when safety devices are overridden are recorded in the data recording device for subsequent evaluation.

Fast-approach circuit



1 Fast-approach circuit switch





	 <b>CAUTION</b>
	<p><b>The fast-approach circuit is activated when moving the crane.</b></p> <p>The components of the mobile crane may get damaged due to switching impacts. The load may sway. This may lead to personal injuries and/or material damage.</p> <ol style="list-style-type: none"> <li>1. The fast-approach circuit must be activated before actuating the crane control levers in order to avoid switching impacts.</li> </ol>
	<p>The fast-approach circuit is fully effective for controlling only one movement direction. The fast-approach speed decreases when controlling multiple movement directions at a time.</p>

For the crane movements such as hoisting gear/auxiliary hoisting gear "up/down", derrick "up" and telescope "extend/retract", the fast-approach circuit can be activated by pressing one of the "Fast-approach circuit" switches in both the crane control levers.

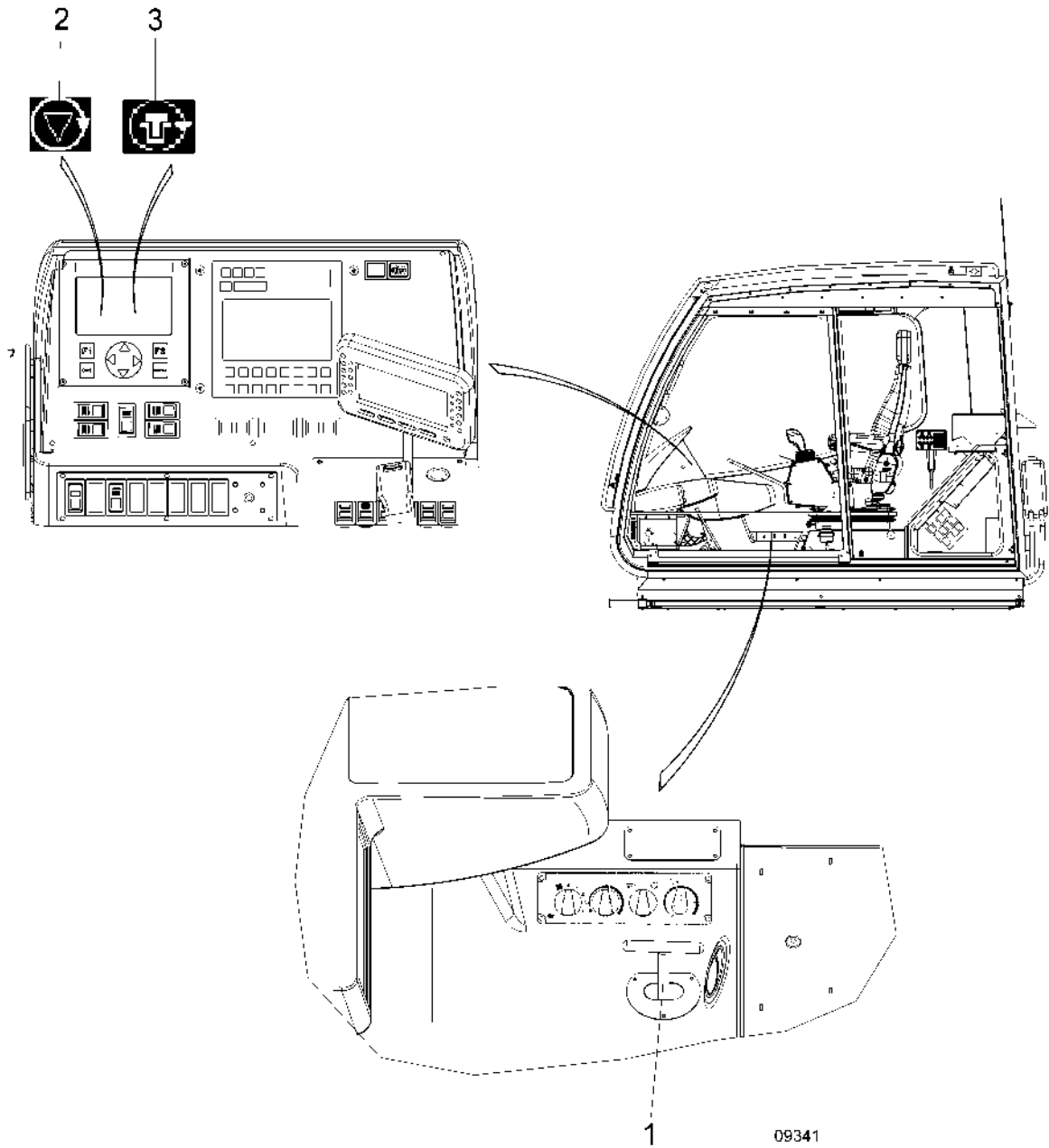

3.9.2 Superstructure lock



1	Superstructure locking bolts	3	Superstructure locked symbol
2	Superstructure can be slewed symbol		

	<b>! WARNING</b>
	<p><b>The superstructure is not locked!</b></p> <p>If the superstructure is not locked, the mobile crane may overturn. This can cause injuries to persons, which could sometime be fatal.</p> <ol style="list-style-type: none"> <li>1. The equipped mobile crane may be operated - if allowed, see the notes regarding the lifting capacity charts and Crane operation under load - only if the superstructure is locked using locking bolts.</li> <li>2. The superstructure may be turned only when the mobile crane is supported.</li> </ol>
	<p><b>Attaching and removing the counterweights!</b></p> <p>Counterweights from the counterweight receiver can be attached or removed only when the superstructure is locked using the locking bolts</p>
	<b>NOTICE</b>
	<p><b>The lock is actuated when the superstructure is swiveling!</b></p> <p>This may damage the carrier and the superstructure.</p> <ol style="list-style-type: none"> <li>1. The superstructure may be locked in the position at the back when the superstructure is stationary.</li> </ol>

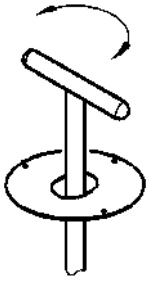
### Engaging the superstructure lock

	<p>Prerequisite: The "Superstructure can be slewed" symbol lights up.</p>
	<p>Swing the superstructure longitudinally "over-rear" to the mark. Raise the locking pin to its stop, turn it to the left to its stop and lower it to its stop.</p>
	<p>After completing the locking process, the "Superstructure locked" symbol will light up.</p>

#### Unlocking the superstructure

	<p>Prerequisite: The symbol "superstructure locked" is lit.</p>
---	---

Raise the locking pin to its stop, turn it to the right to its stop and lower it to its stop.

The "Superstructure locked" symbol will go out and the "Superstructure can be slewed" symbol will light up.

#### 3.9.3 Swing mechanism lock\*)

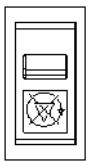
	<p><b>Activating the slewing mechanism lock:</b> Press the "Swing mechanism lock on" rocker switch downwards; the swing mechanism lock will be activated and the pilot lamp in the rocker switch will light up.</p> <p><b>Deactivating the swing mechanism lock:</b> Press the "Swing mechanism lock on" rocker switch upwards; the swing mechanism lock will be deactivated and the pilot lamp in the rocker switch will go out.</p>
---	---

#### Locking the superstructure:

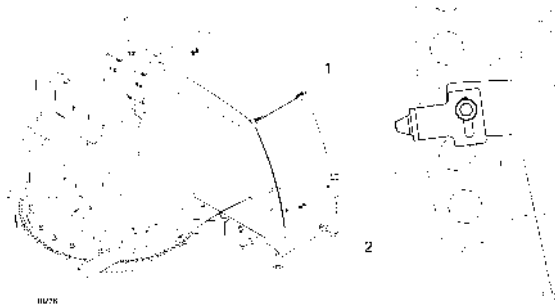

Activate the swing mechanism lock, turn the superstructure slowly until the indicator (1) completely meshes with the tooth (2) of the turntable at the desired stop position.

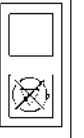

	<p>Press the "Lock/unlock swing mechanism" rocker tip switch downwards until the green "Swing mechanism locked" pilot lamp lights up.</p>
	<p>The green "Swing mechanism locked" pilot lamp lights up; the superstructure is correctly locked.</p>

	<p><b>NOTICE</b></p>
	<p><b>Superstructure cannot be locked!</b> If the indicator does not mesh correctly with the tooth, the superstructure cannot be locked.</p> <p>1. Turn the superstructure carefully and slowly until it is locked.</p>

## Unlocking the superstructure:

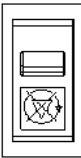

	<p><b>! WARNING</b></p> <p><b>Unlocking process not completed!</b> If the unlocking process is not completed, turning the superstructure may damage the mobile crane.</p> <ol style="list-style-type: none"> <li>1. Actuate the swing mechanism only after completing the unlocking process.</li> <li>2. Press the "Lock/unlock swing mechanism" rocker tip switch upwards until the no warning signal is sound after deactivating the swing mechanism lock.</li> </ol>
	<p>Press the "Lock/unlock swing mechanism" rocker tip switch upwards; the green "Swing mechanism locked" pilot lamp will go out.</p>
	<p>Press the "Swing mechanism lock on" rocker switch upwards; the swing mechanism lock will be deactivated and the pilot lamp in the rocker switch will go out. <b>The unlocking process is not executed completely if a warning signal is sound.</b> Repeat the process.</p>

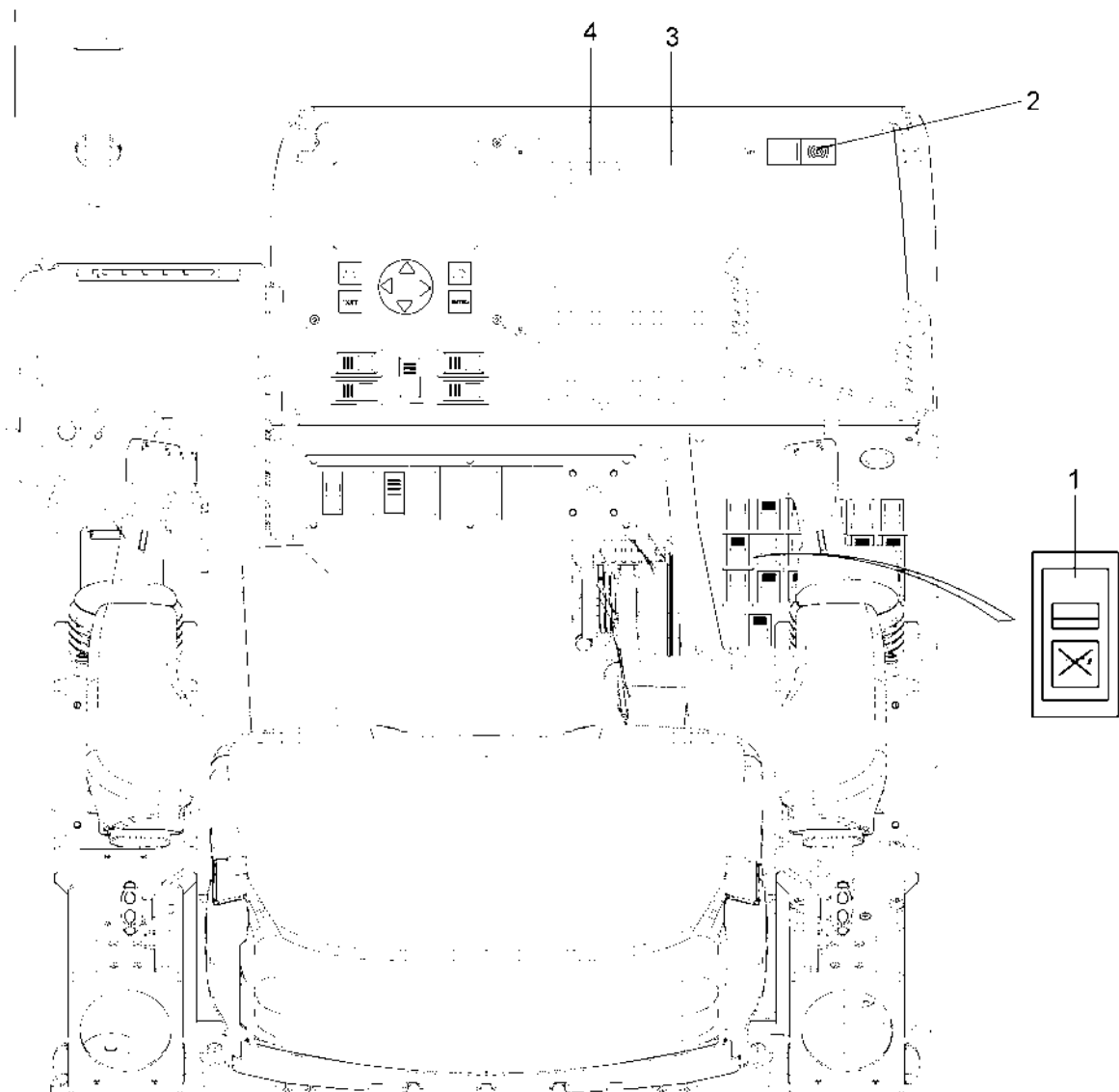
3.9.4 Overriding the slew/derrick slow-stop function



09378

1	Rocker switch for releasing the slewing range limit	3	Automatic safe load indicator display
2	Warning buzzer of the automatic safe load indicator	4	LED display

	 <b>WARNING</b>
	<p><b>Slew/derrick movement stopped abruptly!</b> Abrupt stopping may lead to uncontrolled swaying of load. Risk of accident!</p> <ol style="list-style-type: none"> <li>1. Carry out the slew/derrick movements carefully.</li> </ol>

A range for the safety working range for slewing or boom angle can be entered in the automatic safe load indicator.

The speed of slew or derrick movements will be reduced on approaching this limit range. At the same time, a warning message will be displayed in the automatic safe load indicator display and a warning buzzer will sound (slow interval tone).

The movement will be stopped once the limit is reached. The automatic safe load indicator warning buzzer (fast interval tone) will sound, a warning message will be shown on the automatic safe load indicator display and the LED display will flash.

#### Overriding:

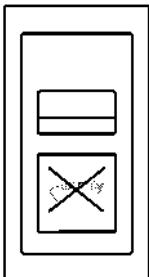
	<p>Unlock the rocker switch for "releasing the slewing range limit" by pressing the locking handle downwards and pressing the rocker tip switch downwards. The locking handle returns to the stop position automatically. The slow-stop function is overridden.</p>
--	---

The entered slewing range can be exceeded. Acoustic and optical warnings shall be triggered in this case as well.

When the boom reaches the set range, the derrick movement is not slowed down, but stopped abruptly. The load may swing back and forth. Acoustic and optical warnings shall be triggered in this case as well.

#### Deactivating the override:

Press the locking handle downwards and the rocker switch upwards. The slewing range limit is now re-activated.

3.9.5 Assigning the crane control levers

Slewing the superstructure/slewing gear brake

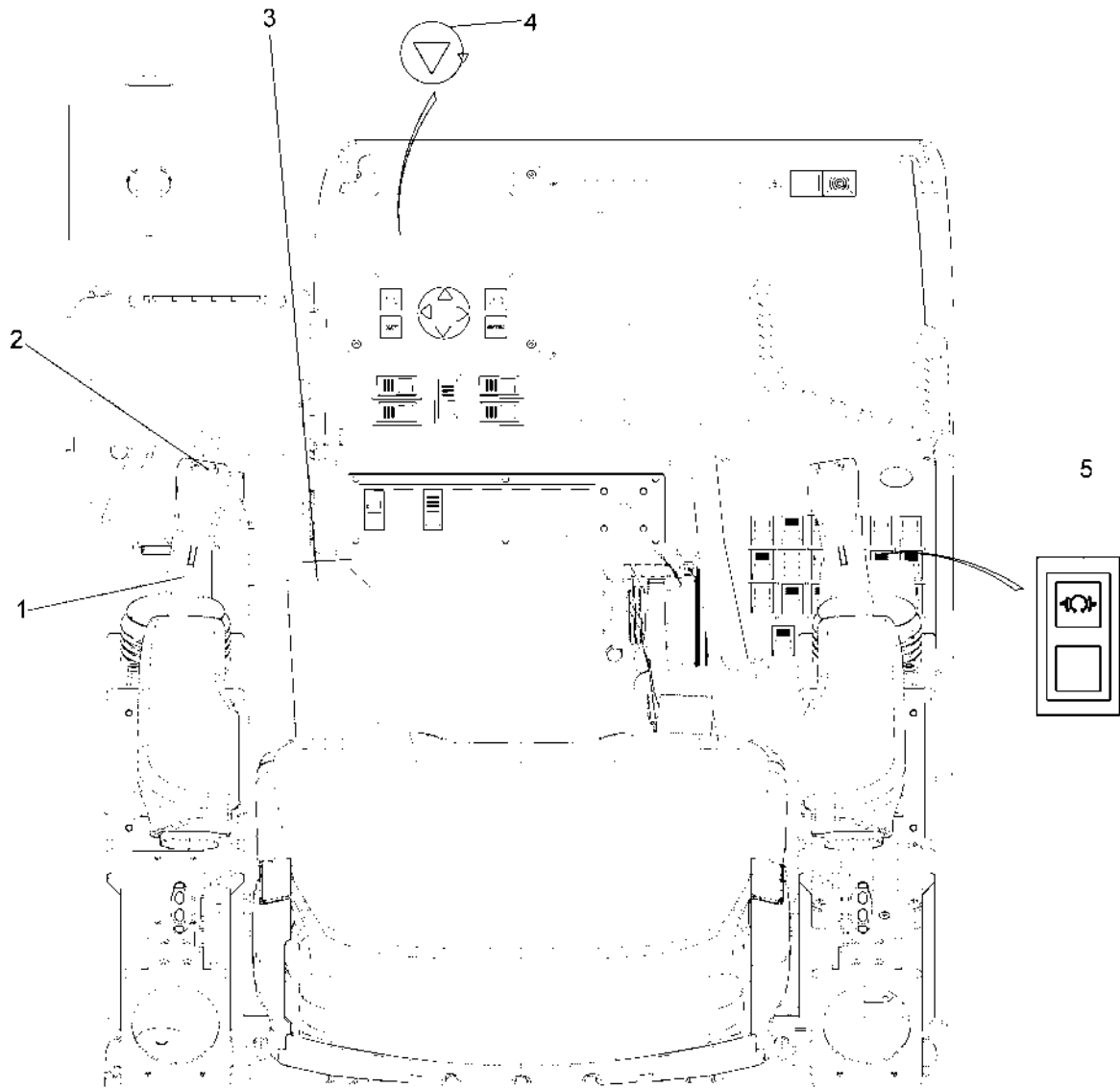

10234

1	Left crane control lever	4	Superstructure can be slewed symbol
2	Rocker switch for the slewing gear brake	5	Slewing gear opened warning lamp
3	Foot pedal of the slewing gear brake		



	<p><b>! WARNING</b></p> <p><b>Obstacles in the slewing range!</b> The superstructure and/or the load may collide with the obstacle. Risk of accident!</p> <ol style="list-style-type: none"> <li>1. Before every slewing movement, ensure that there are not obstacles in the slewing range.</li> </ol>
	<p><b>! WARNING</b></p> <p><b>The mobile crane is not supported when slewing the superstructure!</b> The mobile crane tips over.</p> <ol style="list-style-type: none"> <li>1. The superstructure may be slewed only when the mobile crane is supported.</li> </ol>
	<p><b>! WARNING</b></p> <p><b>The slewing movement is induced or slowed down too quickly!</b> The load may swing back and forth due to excessively quick slewing and braking. Risk of accident!</p> <ol style="list-style-type: none"> <li>1. The slewing movement must be induced and slowed down finely.</li> <li>2. The more the load or the boom length, the slower should be the rate of inducing/ slowing the slewing movement.</li> </ol>

### Slewing the superstructure

	<p>The superstructure is not locked, the 'Superstructure can be slewed' symbol lights up.</p>
---	---

Apply the slewing gear brake. Otherwise, the superstructure will not be braked automatically.

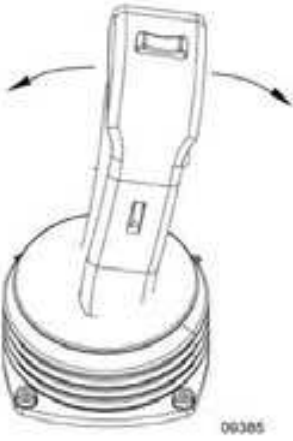
	<p>Left crane control lever</p> <p>To the right - the superstructure slews to the right To the left - the superstructure slews to the left</p>
---	--

The slewing speed can be controlled depending on the deflection of the crane control lever and by changing the engine speed.

When the slewing gear brake is engaged, the superstructure is slowed down automatically when retracting the crane control lever to the middle position "0".

or:

when the slewing gear brake is released, the foot pedal of the slewing gear brake is used for slowing down finely.

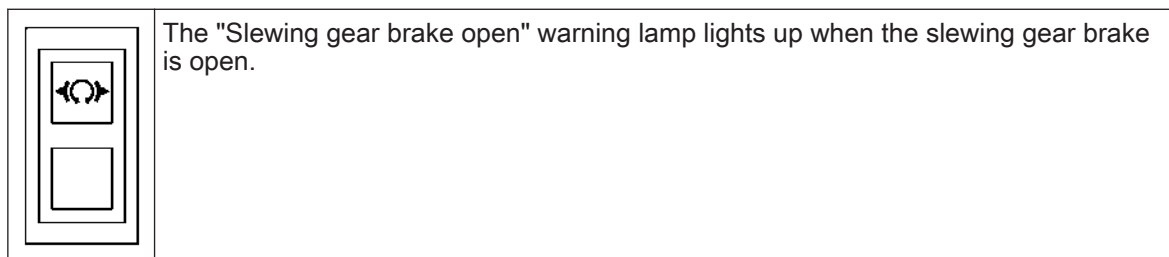
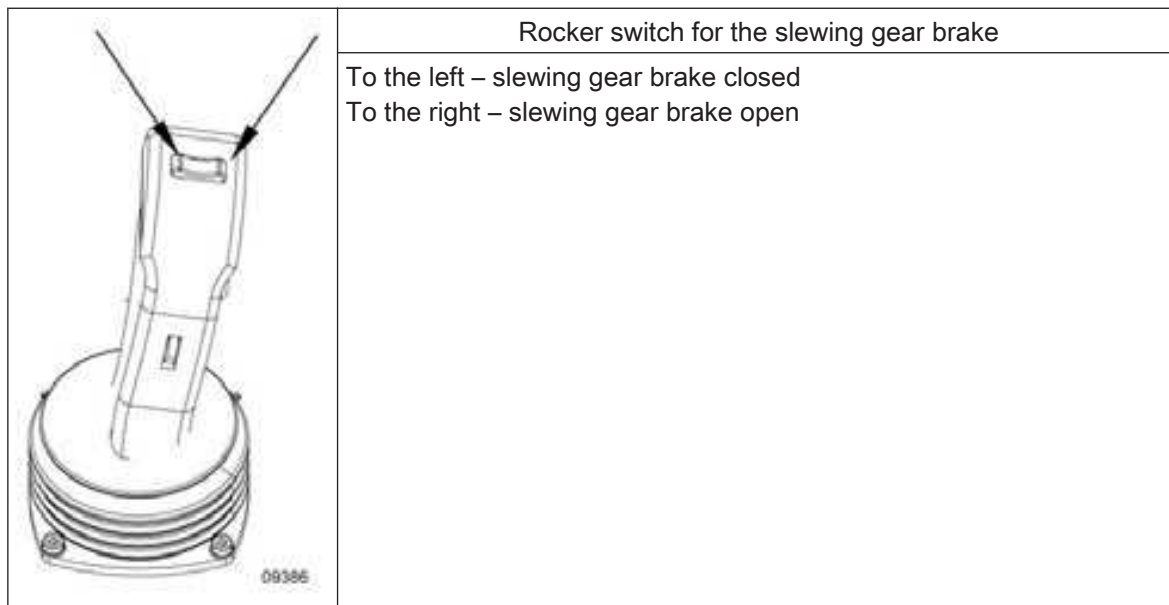

When the slewing gear brake is released, the superstructure must be slowed down to a standstill using the foot pedal of the slewing gear brake. Only then the slewing gear brake may be applied by pressing the Slewing gear brake rocker switch.

	<p><b>! WARNING</b></p>
	<p><b>Uncontrolled slewing of the superstructure!</b> If the slewing gear brake is open, it may lead to uncontrolled slewing of the superstructure. Risk of accident!</p> <p>1. Apply the slewing gear brake before leaving the crane cab.</p>

Hoisting gear / 2nd hoisting gear\*)

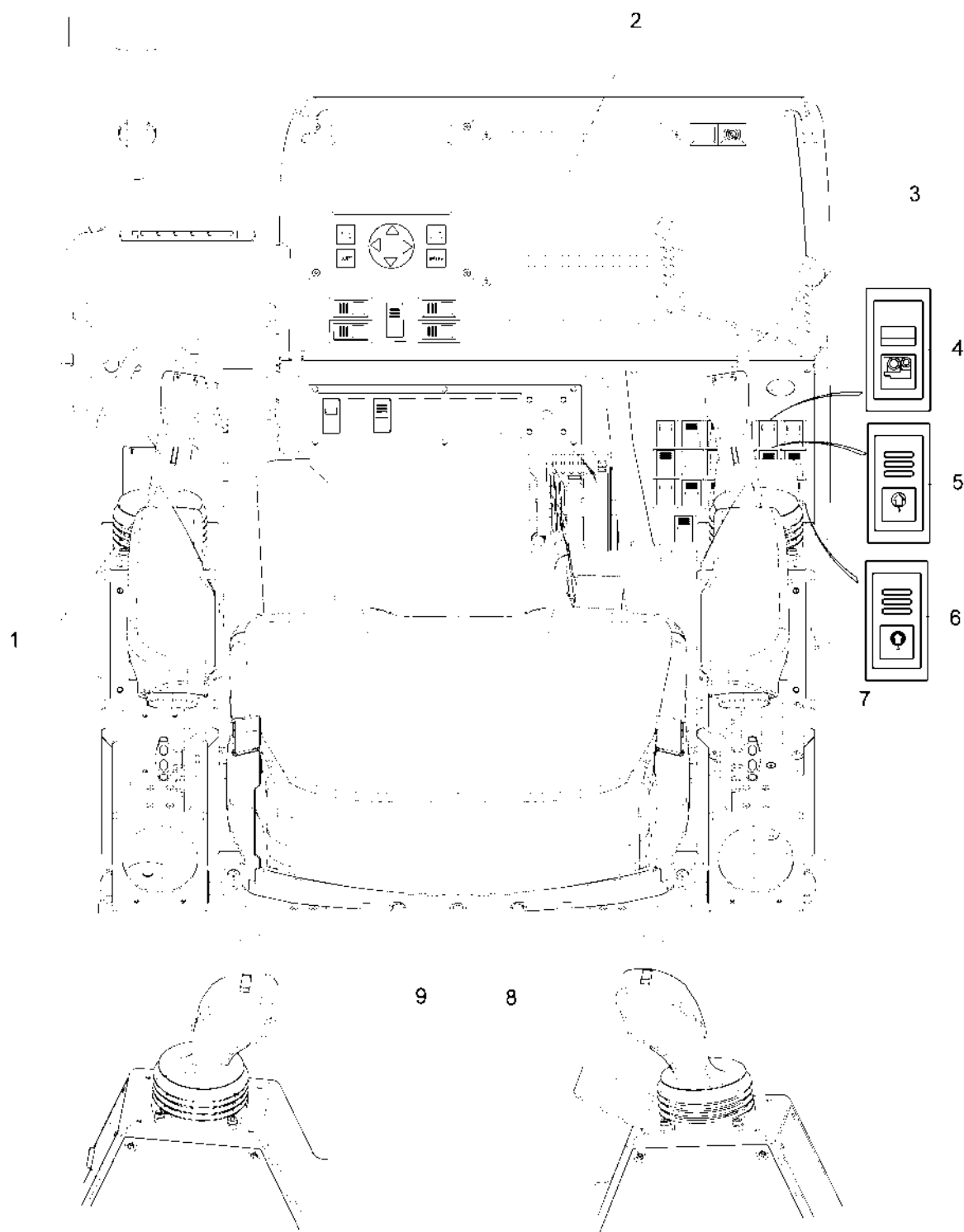



10233

1	Left crane control lever	6	Rocker switch for displaying the lifting height of hoisting gear 2
2	Automatic safe load indicator display	7	Right crane control lever

3	Rocker switch for toggling the crane control lever	8	Fast-approach hoisting gear switch
4	2nd hoisting gear on rocker switch	9	Fast-approach hoisting gear switch
5	Rocker switch for displaying/resetting the lifting height of hoisting gear 1		

#### Hoisting gear

	 <b>WARNING</b>
	<p><b>Bottom block without load lowered too quickly!</b></p> <p>A slack rope would be possible on the winch.</p> <p>The higher the number of rope falls, the higher is the probability of the slacking of the rope when lowering the bottom block at high speed.</p> <p>This may damage the winch and the hoisting rope. The hoisting rope may break under load. Risk of accident!</p> <p>1. Unwind the hoisting gear slowly and without any jerks to avoid a slack rope.</p>

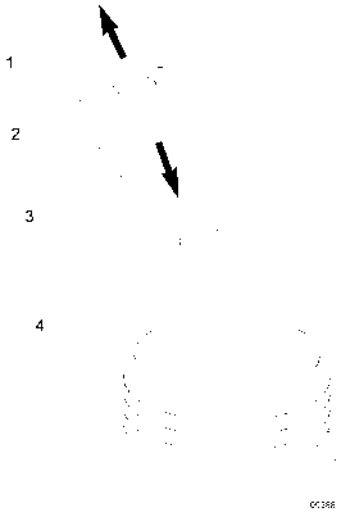
	Right crane control lever (4)
	Unwind the hoisting rope from the initial position (2) to the front (1),
	Wind the hoisting rope from the initial position (2) to the rear (3),

The hoisting gear speed can be controlled depending on the deflection of the crane control lever and by changing the engine speed.

Once the hoisting gear reaches the highest bottom block position, it is deactivated using the anti-twoblock device. Unwinding is however possible.

It is also deactivated if the maximum permissible rope load is reached when lifting. Unwinding is however possible.

The hoisting gear is deactivated using the rope end switch before the rope end on the lifting drum is reached (there are at least 3 windings).

#### Fast-approach

Press the Fast-approach switch.

The hoisting gear speed is also increased until this switch is pressed.

The fast-approach circuit must be activated before actuating the crane control lever.

If a load is attached to the hook, the fast-approach circuit should not be activated.

### Bottom block height display

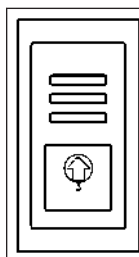

Set the "Display/reset the bottom block height" rocker switch to the second position and press the switch. The bottom block height of the hoisting gear at the current position will be set to 0

Press the rocker switch downwards to the middle position.

The bottom block height of the hoisting gear will be shown on the automatic safe load indicator display with respect to the previously set 0 position.

If the vehicle is equipped with the 2nd hoisting gear\*), the lifting height of the auxiliary hoisting gear is also set to position 0.

For other specifications, also see the description of the automatic safe load indicator.

### 2nd hoisting gear

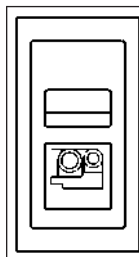

#### Activate the 2nd hoisting gear:

Press the "2nd hoisting gear on" rocker switch.

2. The 2nd hoisting gear will be activated and the pilot lamp in the rocker switch will light up.

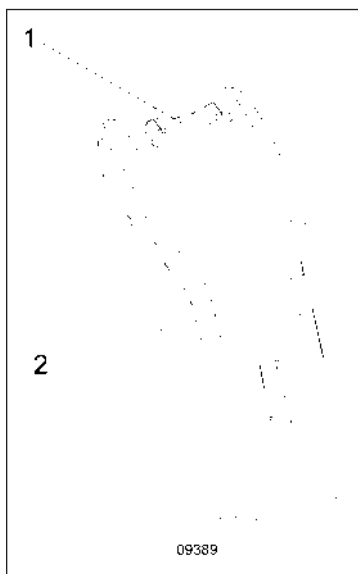

Press the rocker switch for toggling the crane control lever to the left. The 2nd hoisting gear will be activated.

The assignment of the left crane control lever is changed

The boom cannot be telescoped until the left crane control lever is toggled.

#### Assigning the left crane control lever

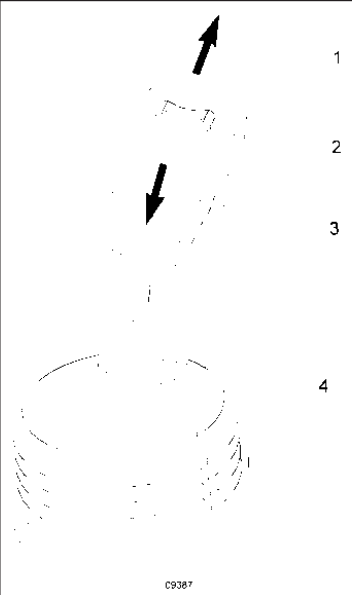
		Left crane control lever (4)
	1	Unwind the hoisting rope of the 2nd hoisting gear from the initial position (2) to the front (1),
	2	Wind the hoisting rope of the 2nd hoisting gear from the initial position (2) to the rear (3),
	3	
4		

The hoisting gear speed can be controlled depending on the deflection of the crane control lever and by changing the engine speed.

Once the hoisting gear reaches the highest bottom block position, it is deactivated using the anti-twoblock device. Unwinding is however possible.

It is also deactivated if the maximum permissible rope load is reached when lifting. Unwinding is however possible.

The hoisting gear is deactivated using the rope end switch before the rope end on the lifting drum is reached (there are at least 3 windings).

#### Fast-approach

Press the Fast-approach switch.

The hoisting gear speed is also increased until this switch is pressed.

The fast-approach circuit must be activated before actuating the crane control lever.

If a load is attached to the hook, the fast-approach circuit should not be activated.

#### Deactivate the 2nd hoisting gear:

Deactivate the 2nd hoisting gear in the logical reverse order.

The default assignment of the left crane control lever, i.e. telescoping the boom, shall be re-activated.

	<p>The 2nd hoisting gear is primarily used with a jib (single-line reeving). If the hoisting gear fails, the 2nd hoisting gear can also be reeved on the singlesheave boom top of the main boom.</p> <p>The anti-twoblock device weight of the hoisting gear must then be attached to the hoisting rope of the 2nd hoisting gear.</p>
---	---

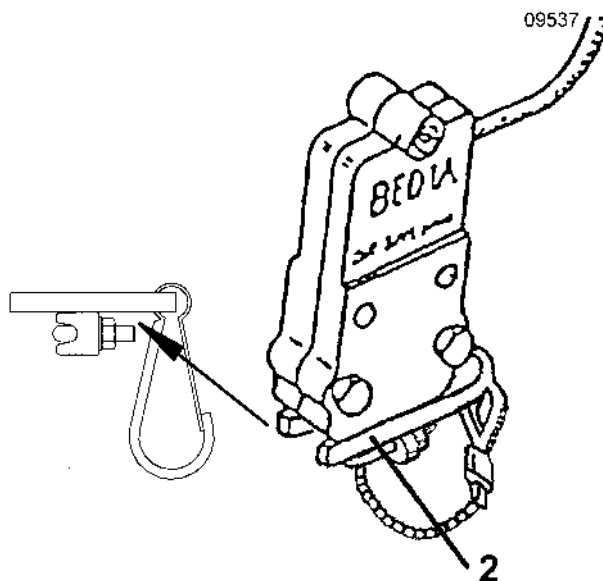

**i**

If only the 2nd hoisting gear is used through the jib, the anti-twoblock device on the single-sheave boom top of the main boom can be freely operated using the clamping piece (2). Otherwise, the control is deactivated.

#### Bottom block height display

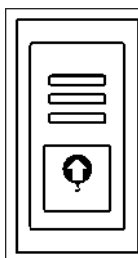

Press the rocker switch for displaying the lifting height of hoisting gear 2. The bottom block height of the hoisting gear will be shown on the automatic safe load indicator display with respect to the previously set 0 position.

#### Drum rotation indicator

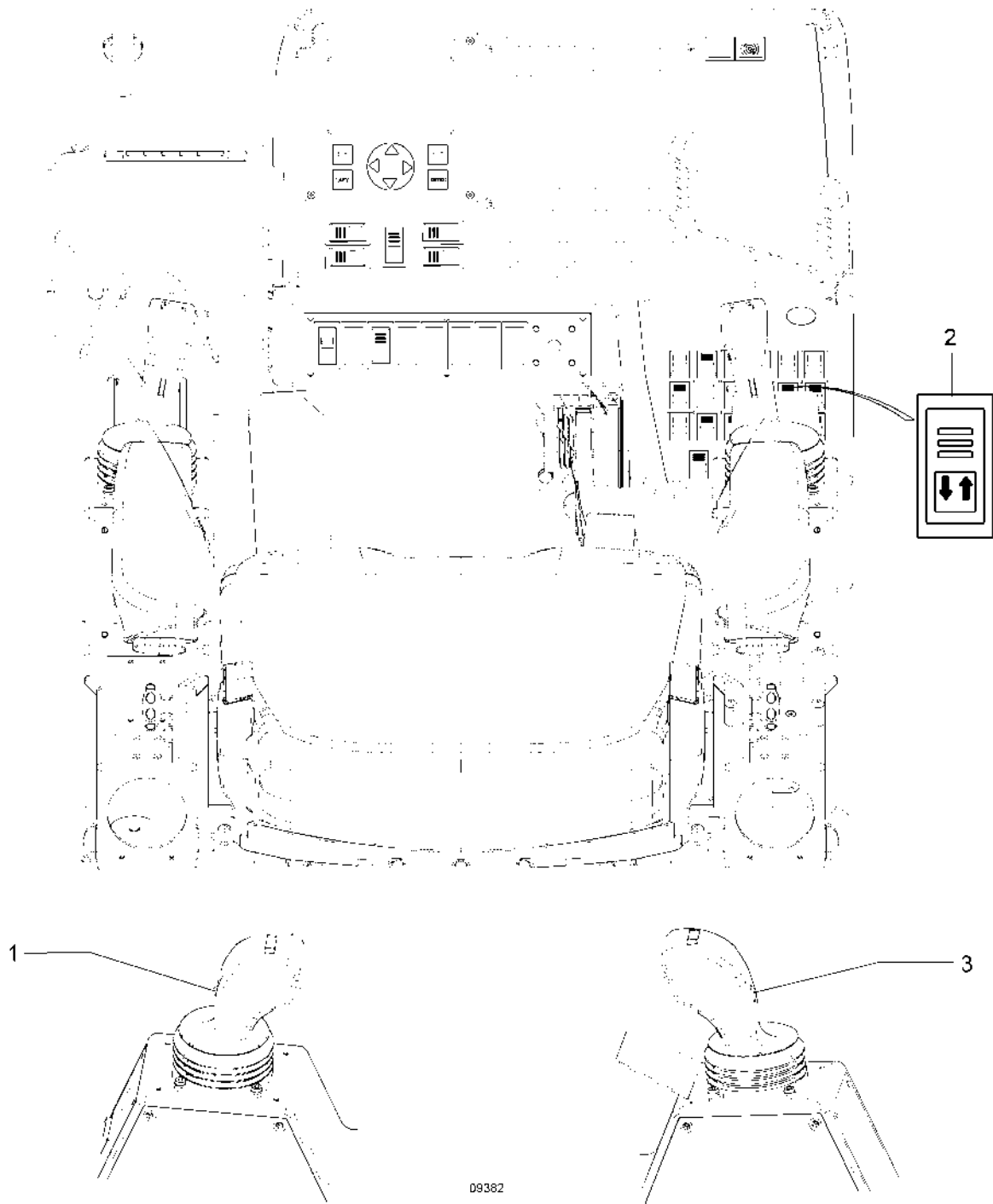

1	Drum rotation indicator for the 2nd hoisting gear	3	Drum rotation indicator for the hoisting gear
2	Drum rotation indicator rocker switch		

The right crane control lever is equipped with a drum rotation indicator for the hoisting gear. The pulsating vibration indicates the slewing movement of the hoisting gear to the crane driver perceptibly and audibly.



If the 2nd hoisting gear is provided, the left crane control lever is also equipped with a drum rotation indicator.

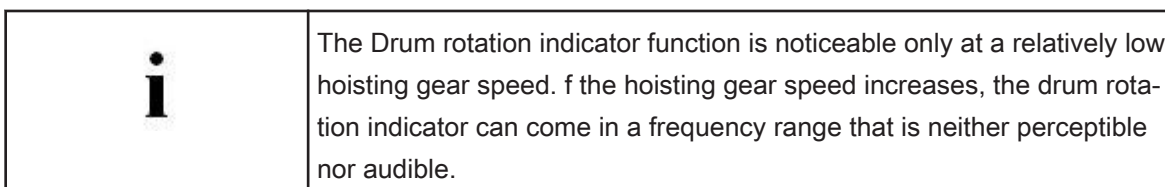
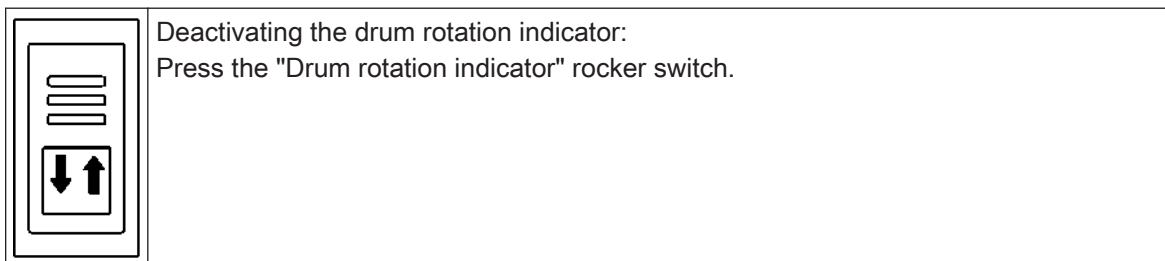

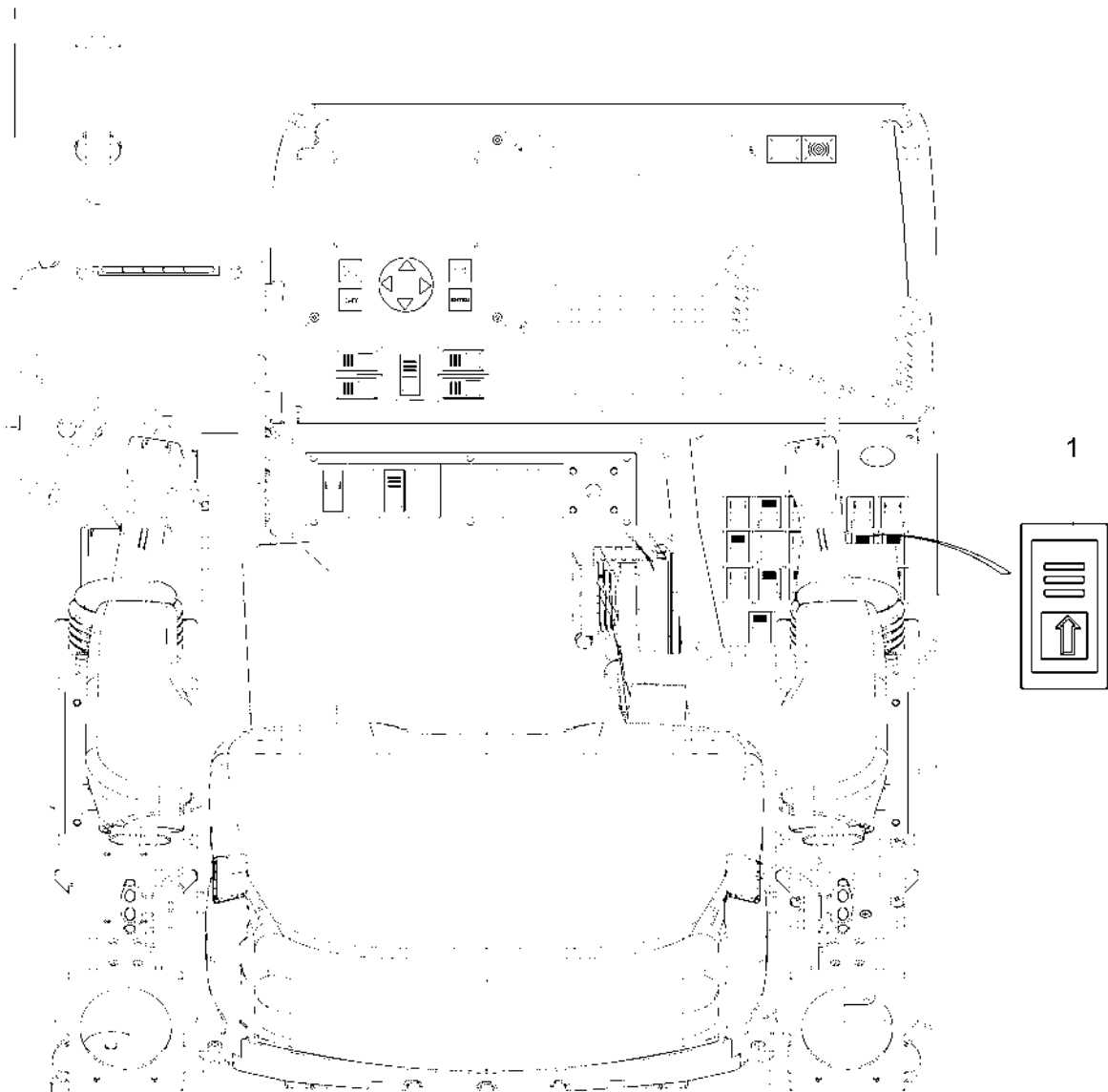

Lift adjuster



09383

1 Lift adjuster rocker tip switch

	 <b>WARNING</b>
	<p><b>The lift adjuster is not used as prescribed.</b>                  The load may start oscillating if it is not lifted properly, or in case of strong wind. Risk of accident!</p> <ol style="list-style-type: none"> <li>1. Sling the bottom block precisely above the centre of gravity of the load.</li> <li>2. Take the wind conditions into account.</li> </ol>

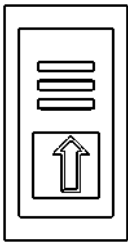
	<p>Press the "Lift adjuster" rocker tip switch.          The "Lift adjuster" will be activated.          Press the "Lift adjuster" rocker tip switch again.          The "Lift adjuster" will be deactivated.</p>
---	---

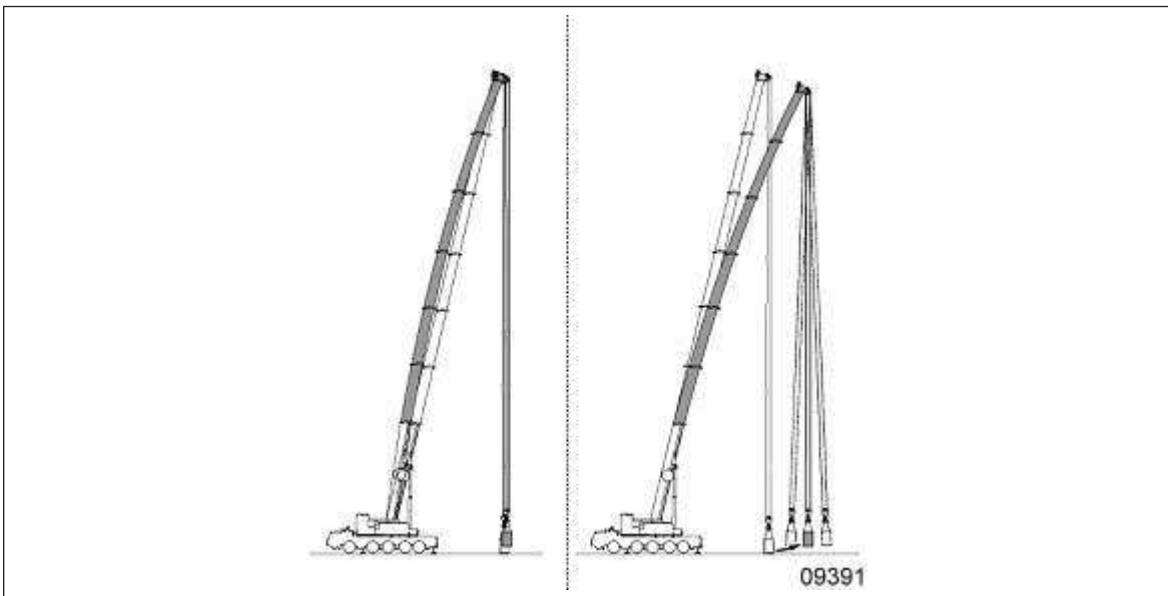

**Lift adjuster activated**

When the hoisting rope is wound, the boom is deflected owing to the weight of the load.  
 The boom is raised by the automatic control (lift adjuster) to compensate the boom deflection.  
 The load can now be lifted without appreciable swaying.

**Lift adjuster deactivated**

When the hoisting rope is wound, the boom is deflected owing to the weight of the load.  
 If the load is lifted, it will sway.  
 To prevent the load sway, the crane driver must raise the boom before lifting the load off the ground.

For further information, refer to the description of the automatic safe load indicator, Lift adjuster.

#### Luffing the telescopic boom

#### Overview of the operating elements

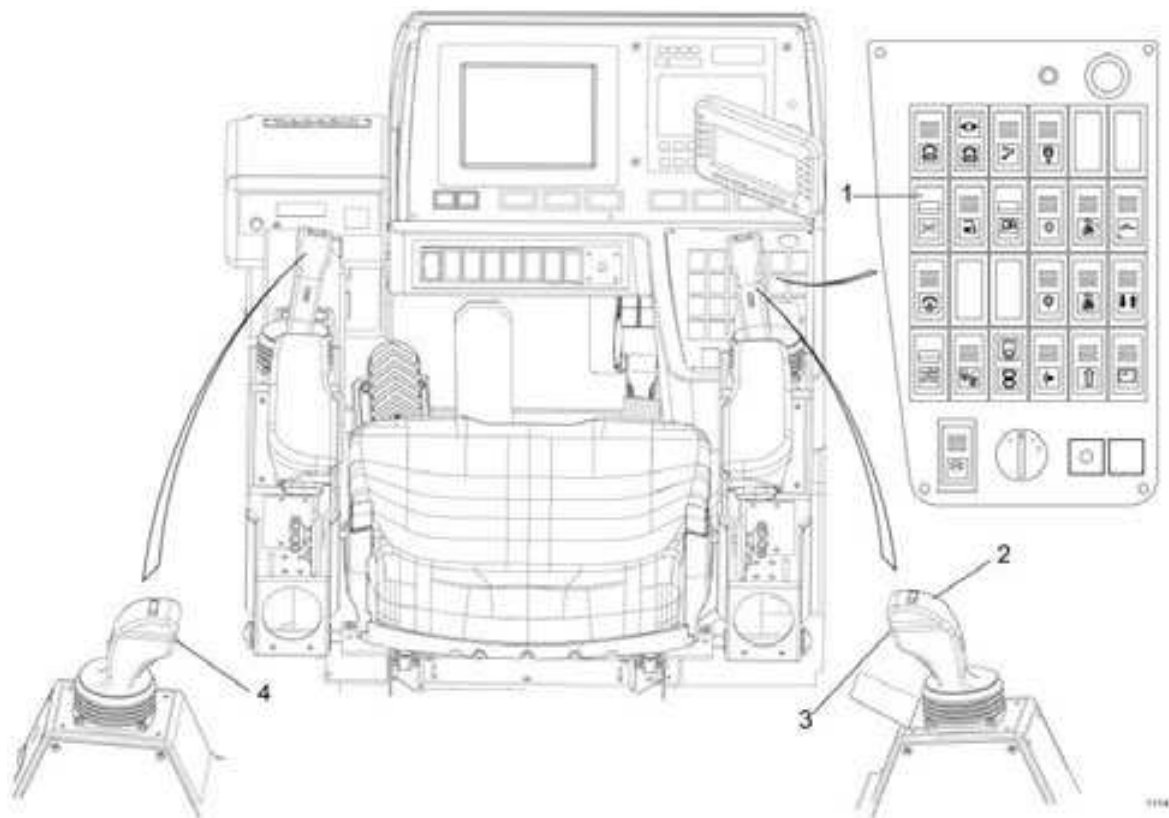

1	Switch for <i>releasing the slewing range limit / deactivating the slow-stop function</i>	3	<i>Fast-approach</i> switch
2	Right crane control lever	4	<i>Fast-approach</i> switch

#### Right crane control lever



#### Raising telescopic boom

1. Move the right crane control lever inwards.

The speed at which the boom is raised can be changed as follows:



- Deflection of the crane control lever.
- Changing the engine speed.
- Activating fast approach.

#### Lowering telescopic boom

1. Move the right crane control lever outwards.



The speed at which the boom is lowered can be changed as follows:

- Deflection of the crane control lever.

	 <b>WARNING</b>
	<p><b>Pivoting out the load.</b></p> <p>If the load is pivoted out too quickly or too far, it will result in an overload and may cause an accident (overturning, etc.).</p> <ol style="list-style-type: none"> <li>1. Increasing the working radius ("luff boom down") with a load must be carried out slowly and carefully, as the automatic safe load indicator stops when the maximum working radius is reached.</li> </ol>

The working radius (lowering the boom) with the load must be increased slowly and carefully. The automatic safe load indicator switches off on reaching the maximum working radius (also see the description of the automatic safe load indicator).

After it switches off, only a load moment-reducing movement (raising the boom) can be carried out.

	 <b>DANGER</b>
	<p><b>Overloading of the mobile crane.</b></p> <p>Lifting the loads on the ground by raising the boom can lead to boom overload or can also cause the crane to tilt.</p> <ul style="list-style-type: none"> <li>▶ Loads may not be dragged.</li> </ul> <ol style="list-style-type: none"> <li>1. Carry out load movements only using the hoisting winch.</li> <li>2. Lift the loads only vertically.</li> </ol>

	<p>If the crane control lever is moved diagonally, the hoisting winch can be actuated simultaneously.</p>
---	---

### Slow-stop function

For overriding the slow-stop function, refer to chapter "Overriding the Slew/Derrick slow-stop function".

Boom telescoping operation

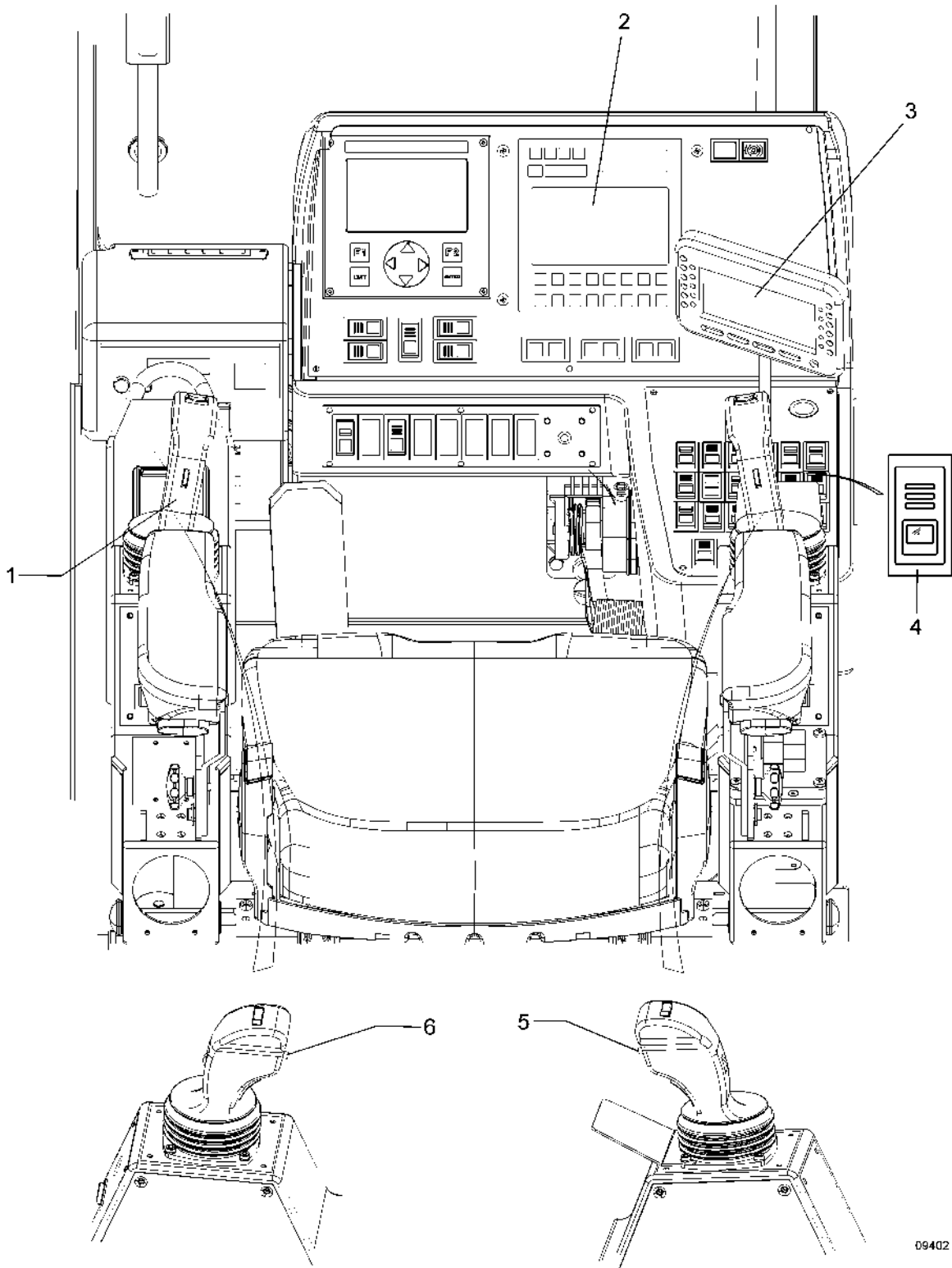

1	Left crane control lever	4	Monitor on/off rocker tip switch
2	Automatic safe load indicator display	5	Fast-approach circuit switch
3	Monitor	6	Fast-approach circuit switch

Determine the required boom length exactly before starting work.

Enter the target telescope state in the operator panel of the automatic safe load indicator. Determine the desired boom length using the lifting capacity charts and the lifting height diagram.

When telescoping, the boom must be raised at least to 75°.

Do not derrick it during the telescoping operation.

The data for changing the counterweight variants or outrigger variants can be entered only when the telescope is retracted.

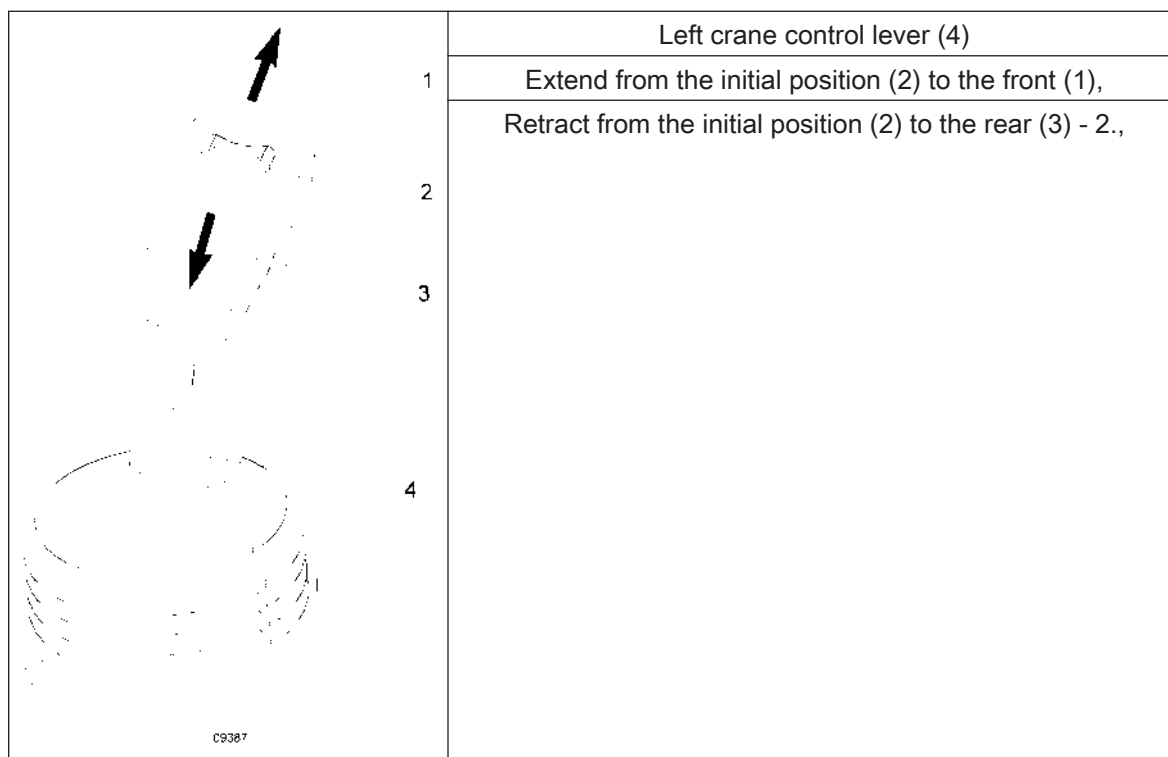

The telescoping speed can be controlled depending on the deflection of the crane control lever and by changing the engine speed.

The telescope extends as per the required setup condition.



#### Press the Fast-approach switch.

The telescoping speed is also increased until this switch is pressed.

The fast-approach circuit must be activated before actuating the crane control lever.

If a load is attached to the hook, the fast-approach circuit should not be activated.

#### Telescoping

	 <b>WARNING</b>
	<p><b>Defect in the length transmitter rope!</b></p> <p>The automatic safe load indicator fails. The mobile crane may be overloaded and may overturn. Risk of accident!</p> <p>1. Further work should not be carried out. Decrease the load. Retract the boom manually. Rectify the damage immediately.</p>



If a fault occurs in the control program when telescoping, the telescope can be reset as described in chapter "Resetting the telescope manually".

Extend the boom to the desired length.

The telescope control and the automatic safe load indicator ensure the correct telescoping sequence automatically.

Only the boom length which is essential for operating the crane should be used.

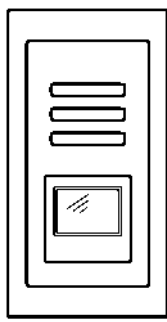

Press the 'Monitor' rocker tip switch.  
Information regarding the telescope state will be shown on the monitor.  
Press the "Monitor" rocker tip switch again. The monitor will be switched off.

#### Telescoping operation

Switch on the ignition and start the engine.

The automatic safe load indicator program will be started.

The Start menu will appear.

Determine the data required for operating the crane (load, boom length, etc.) before starting the crane operation.

Enter this data in the automatic safe load indicator.

The automatic safe load indicator is user-friendly and guides the operator through the program.

Program the automatic safe load indicator using the data determined earlier.

Actuate the crane control lever.

The telescopes will extend automatically in the correct sequence starting from the smallest telescope up to the corresponding telescope test.

Telescoping sequence: 5, 4, 3, 2 and 1.

Depending on the telescope state, it is sometimes not possible to switch to another telescope state without resetting (e.g. from 100/100/50/50/0 to 100/100/100/50/0).

Additional information is given in the notes to lifting capacity table or the description of the automatic safe load indicator.

Operate the crane as described.

#### Telescoping loads

All instructions and guidelines for crane operations given in this operating manual are applicable when working with telescoping loads.

Telescoping under load is possible in a particular range limited by hydraulic conditions.

Settings for the default operating mode must be entered in the automatic safe load indicator. If permissible values overshoot in this operating mode, it leads to deactivation.

Pinning may not be done when telescoping under load.



However, if the operator tries telescoping under load after pinning, the automatic safe load indicator switches to the default operating mode.

If permissible values are exceeded, it leads to deactivation.

**Telescoping**

The mobile crane is equipped with a single-cylinder telescoping system. Booms are gradually extended starting from the uppermost boom part. Booms are locked in their position using bolts.

Example:

(1) Boom fully retracted:

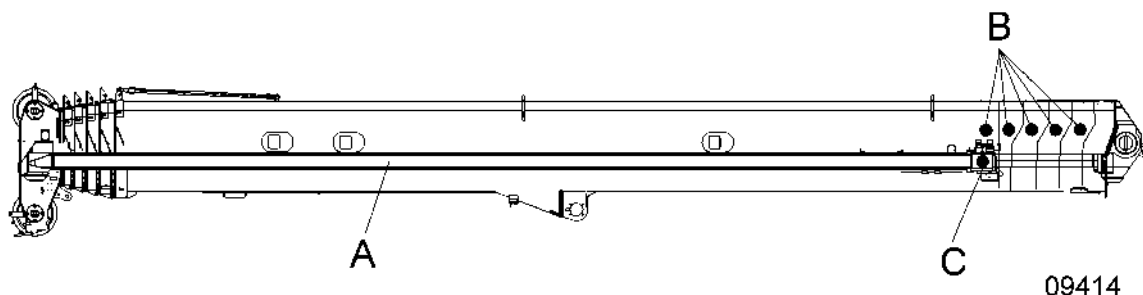

A	Telescoping cylinder	C	C-pin in telescope 5 locked
B	B-pins of all telescopes locked		

(2) Remove the B-pin:

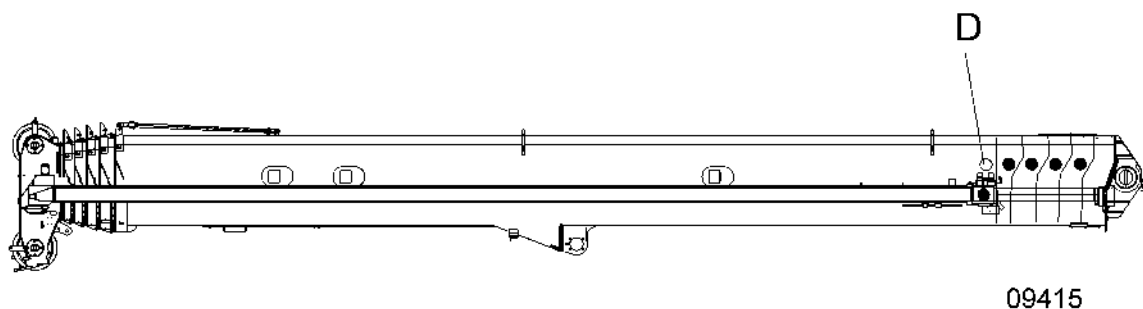

D	B-pin of telescope 4 locked		
---	-----------------------------	--	--

(3) Extend telescope 5:

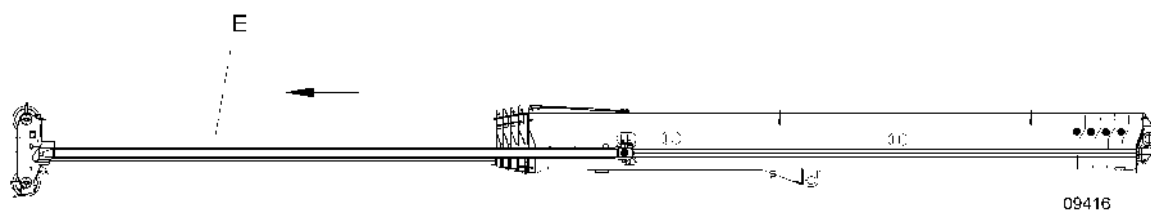

E	Telescope 5		
---	-------------	--	--

(4) Lock the B-pin and then unlock the C-pin:

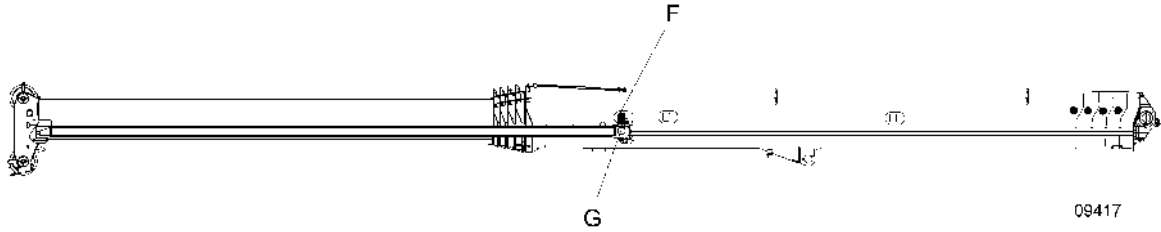

F B-pin in telescope 4 locked	G C-pin in telescope 5 unlocked
-------------------------------	---------------------------------

(5) Retract the telescoping cylinder:

The telescoping cylinder is retracted up to telescope 4.

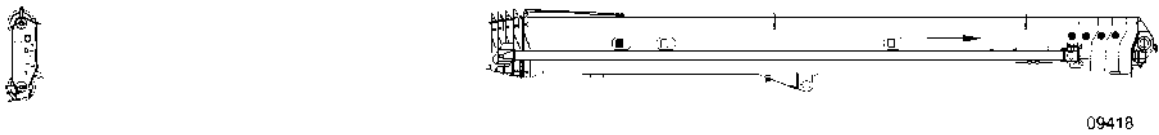

(6) Lock the C-pin and then unlock the B-pin:

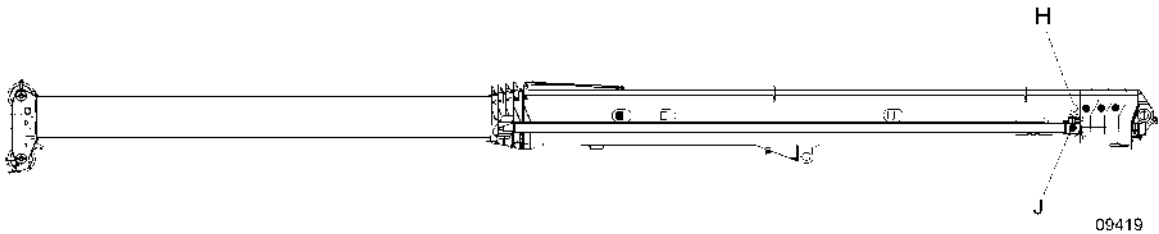

H B-pin in telescope 3 unlocked	J C-pin locked
---------------------------------	----------------

(7) Extend telescope 4:

Steps (3) to (6) are repeated until all telescopes are extended.

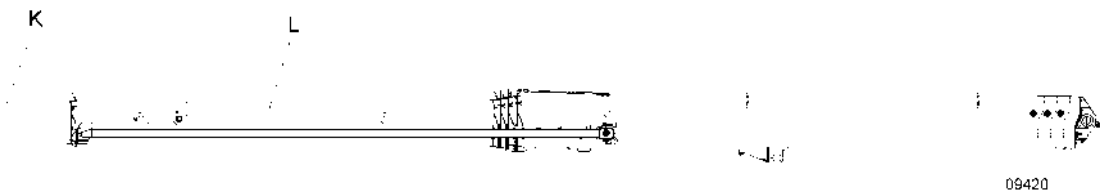

K Telescope 5	L Telescope 4
---------------	---------------

**Telescoping steps:**

The following images show the status of telescope 1 at telescoping steps of 46%, 92% and 100% of the boom length.

These states are the same for the other telescopes.

Telescoping steps with the example of telescope 1.

Boom fully retracted:

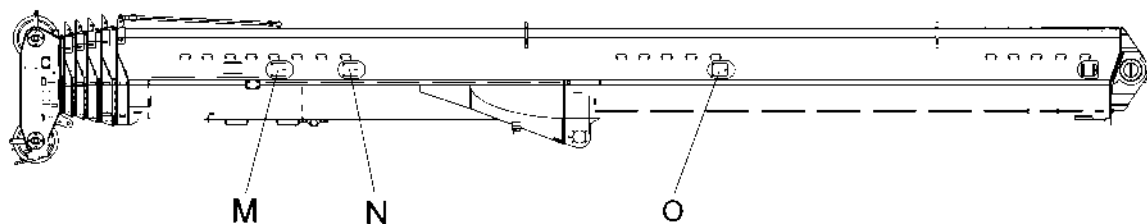

09421

M	B-pin position telescope 100% extended	O	B-pin position telescope 46% extended
N	B-pin position telescope 92% extended		

Telescope 1 46% extended:

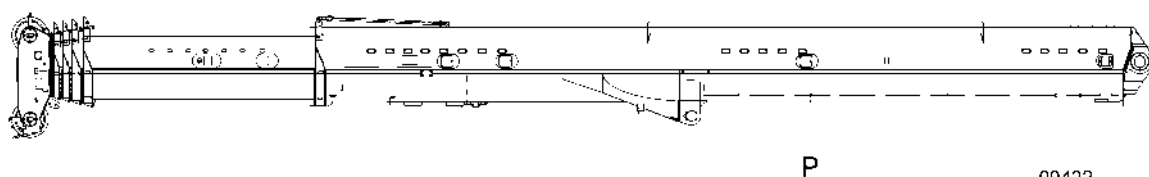

09422

P	B-pin position		
---	----------------	--	--

Telescope 1 92% extended:

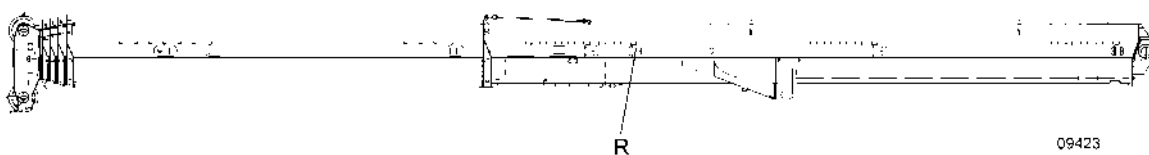

09423

R	B-pin position		
---	----------------	--	--

Telescope 1 100% extended:

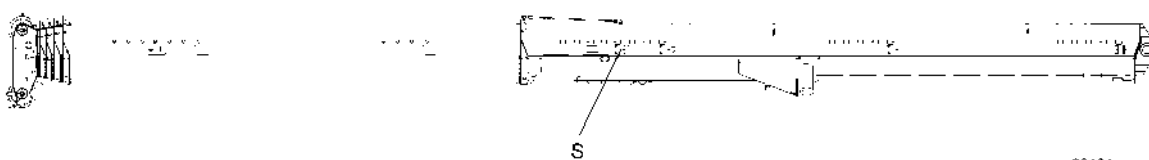

09424

S	B-pin position		
---	----------------	--	--

For more information, see the description of the automatic safe load indicator.

### Luffing the hydraulic jib\*)

Before the jib is angled, the following work must be carried out and instructions followed:

- The mobile crane is supported as prescribed.
- While the jib is being angled, there must be no obstruction within the range of movement.
- The jib is fitted as described under Attaching and detaching the jib.
- The current equipment status is programmed in the automatic safe load indicator.

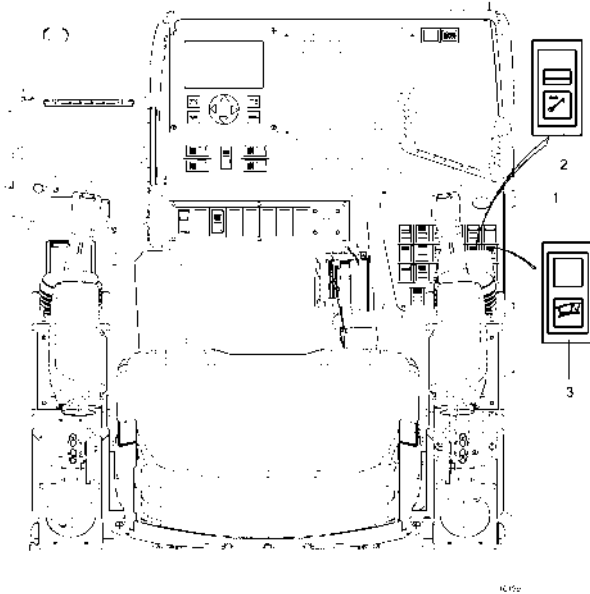

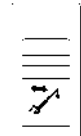

1	Right crane control lever	3	Warning lamp for jib, luffing cylinder not retracted
2	Activate jib luffing rocker switch		

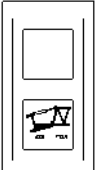
	<p>Operate the "Activate jib luffing" rocker switch, the luffing jib is operational, the green function lamp in the switch lights up to indicate the reassignment of the crane control lever.</p>
--	---



	<p>The red warning lamp "Luffing cylinder not retracted" comes on if the luffing jib is not in the 0° position. This warning lamp is only activated when the luffing jib is in the transport position and is used as a mounting aid.</p>
---	--

	<p>Right crane control lever (4)</p>
	<p>From the initial position (2) to the inside (left) (1) – luff the luffing jib up.</p>
	<p>From the initial position (2) to the outside (right) (3) – luff the luffing jib down.</p>

The raising speed can be controlled depending on the deflection of the crane control lever and by changing the engine speed.



	 <b>WARNING</b>
	<p><b>Pivoting out the load!</b></p> <p>If the load is pivoted out too quickly or too far, it will result in an overload and may cause an accident (overturning, etc.).</p> <ol style="list-style-type: none"> <li>1. Increasing the working radius ("luffing jib down") with a load must be carried out slowly and carefully, as the automatic safe load indicator stops the movement when the maximum working radius is reached.</li> </ol>

After the stop, it is only possible to perform a movement that reduces the load moment (luff up luffing jib).

	 <b>DANGER</b>
	<p><b>Overloading of the mobile crane!</b></p> <p>Lifting the loads on the ground by raising the outrigger can lead to outrigger overload or can also cause the crane to tilt. Upward luffing movements are not switched off by the automatic safe load indicator.</p> <ul style="list-style-type: none"> <li>▶ Loads may not be dragged.</li> </ul> <ol style="list-style-type: none"> <li>1. Carry out load movements only via hoisting gear.</li> <li>2. Lift the loads only vertically.</li> </ol>
	<p>If the crane control lever is moved diagonally, the hoisting gear can be actuated simultaneously.</p>

## 3.10 Rigging and dismantling

### 3.10.1 Counterweights

	 <b>WARNING</b>
	<p><b>Danger of accidents due to incorrect operation!</b></p> <p>Errors when mounting/removing the counterweights may cause accidents.</p> <ol style="list-style-type: none"> <li>1. Observe the following instructions.</li> </ol>

Before attaching or removing the counterweights, the mobile crane must be supported as prescribed.

Ballast cylinders must be retracted completely before a slewing movement.

Neither persons nor objects may be present in the slewing range.

Trigger a warning signal before attaching, removing or slewing.

The counterweights required for the crane operation must be identical to the corresponding lifting capacity chart.

Counterweights of other cranes may not be used.

Damaged counterweights may not be used any longer.

Separately transported counterweights should be as close as possible to the supported carrier when attaching them to the crane. One more crane can also be used.

For attaching or removing the separately transported counterweights to the bottom block, program the "Setup program" intended for this purpose. The working radii and boom lengths specified here may not be exceeded.

Before attaching the entire counterweight, ensure that individual counterweights are correctly stacked over each other.

No ropes, lumbers should be placed between the individual counterweights since they do not ensure a safe condition of counterweights. Counterweights may slip and fall off.

Observe the legal regulations of the licensing country for "Ropes and hoisting equipment".

When attaching the counterweights of the carrier, ensure that the counterweight cylinders retract in the counterweight holes without coming in contact with them. The boom should be raised by approximately 30°. If required, conduct a visual inspection.

The outrigger must be extended completely if the base boom is derricked high and counterweights are attached to the superstructure. Otherwise, there is a risk of the ballast side overturning when slewing the superstructure.

When transferring the partial counterweights mounted on the superstructure to the counterweight storage compartment of the carrier, the locking bolts must be pressed.

After completing the crane operation, the counterweights must be removed and transported separately for the on-road travel by taking into account the legally permitted axle loads.

Owing to reasons pertaining to permission, driving on public roads is allowed only in the suitably adapted vehicle state.

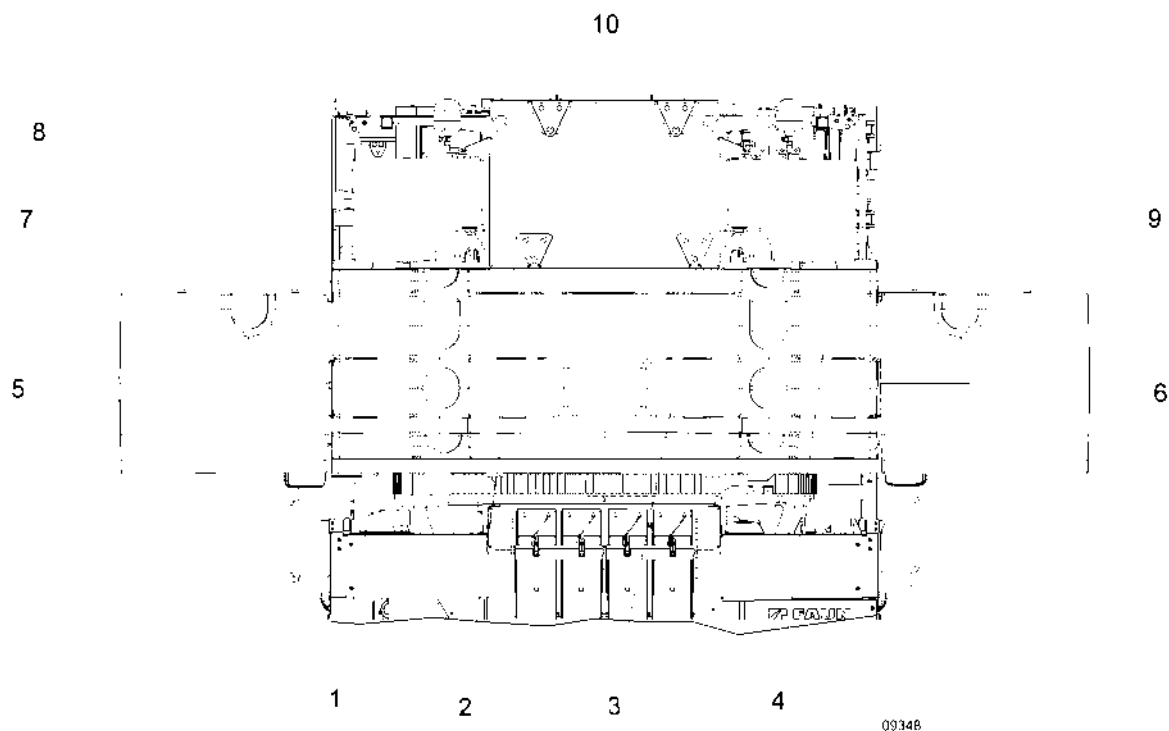

1	Counterweight 2.4 t (5291.1 lbs)	6	Counterweight 5.3 t (11,684.5 lbs)
2	Counterweight 3.4 t (7,495.7 lbs)	7	Counterweight 3.1 t (6,834.3 lbs)
3	Counterweight 8.9 t (19,621.1 lbs)	8	Counterweight 1.2 t (2645.6 lbs)
4	Counterweight 10.0 t (22,046.2 lbs)	9	Counterweight 1.2 t (2645.6 lbs)
5	Counterweight 5.3 t (11,684.5 lbs)	10	Counterweight 1.5 t (3,306.9 lbs)

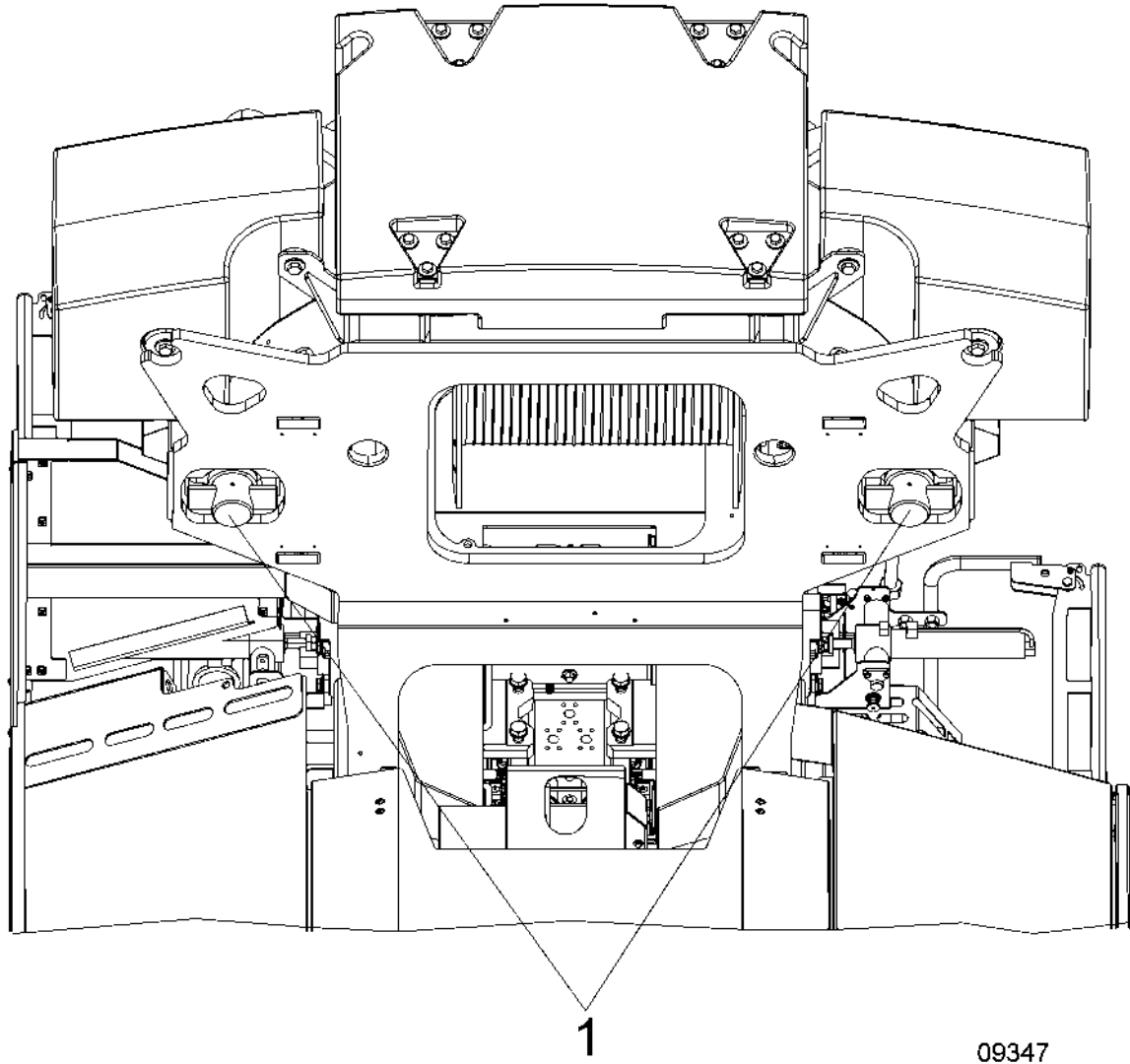

1	Counterweight cylinder		
---	------------------------	--	--



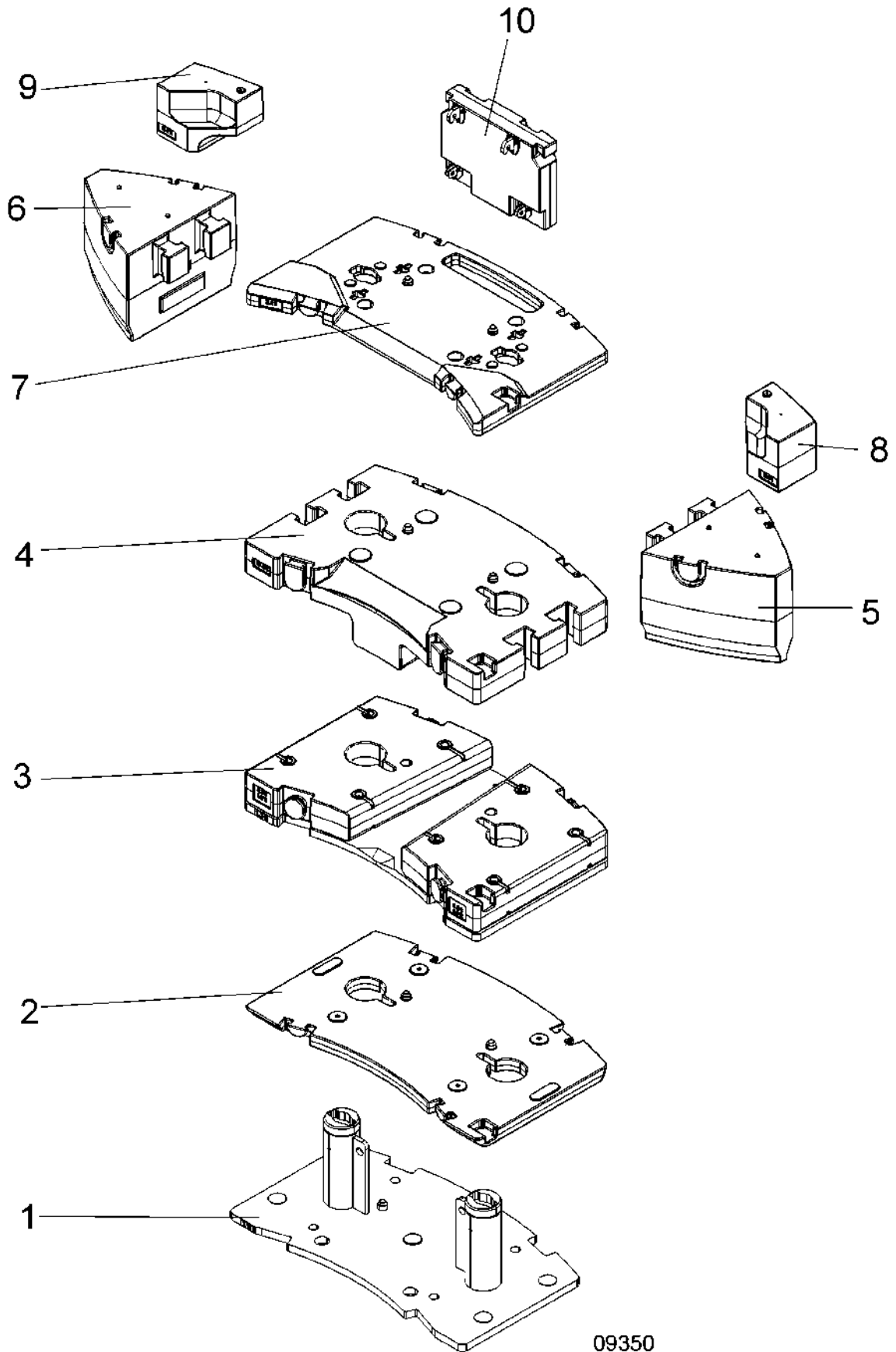



09350

Counterweight	Combination of counterweights
6.3 t (13889.1 lbs)	1 + 8 + 9 + 10
9.4 t (20723.5 lbs)	1 + 7 + 8 + 9 + 10
21.7 t (47840.3 lbs)	1 + 2 + 3 + 7 + 8 + 9 + 10
31.7 t (69886.5 lbs)	1 + 2 + 3 + 4 + 7 + 8 + 9 + 10
42.3 t (93255.5 lbs)	1 + 2 + 3 + 4 + 5 + 6 + 7 + 8 + 9 + 10

#### Counterweight variants

	 <b>WARNING</b>
	<p><b>Risk of accident!</b>            Technical defects in counterweights or counterweight cylinders may cause accidents.</p> <p>1. This must be monitored continuously when mounting/removing the counterweights. Also monitor the pilot lamps.</p>

The mounted counterweight variants are shown in the control device of the automatic safe load indicator.

## Counterweight variant 3.9 t (8,598.0 lbs)

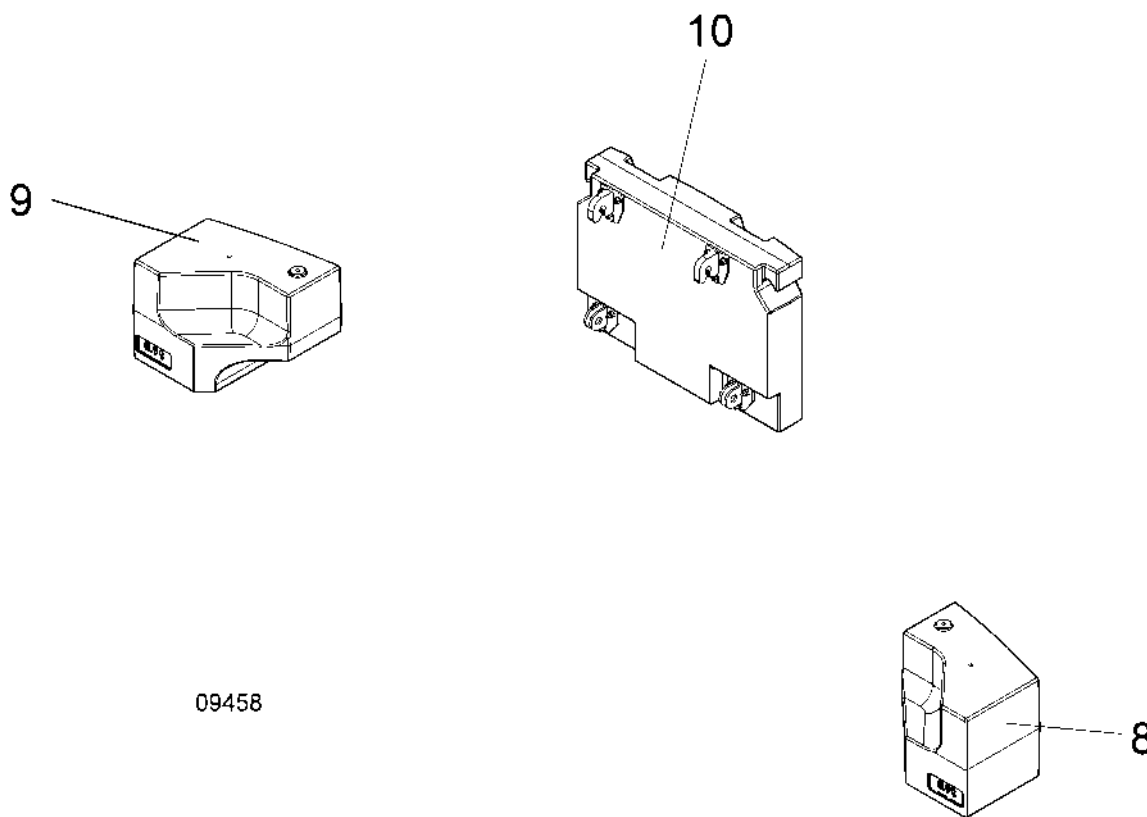

Counterweight variant 3.9 t (8598.0 lbs) comprises:

Counterweight 8: 1.2 t (2645.6 lbs)

Counterweight 9: 1.2 t (2645.6 lbs)

Counterweight 10: 1.5 t (3306.9 lbs)

#### Counterweight variant 6.3 t (13889.1 lbs)

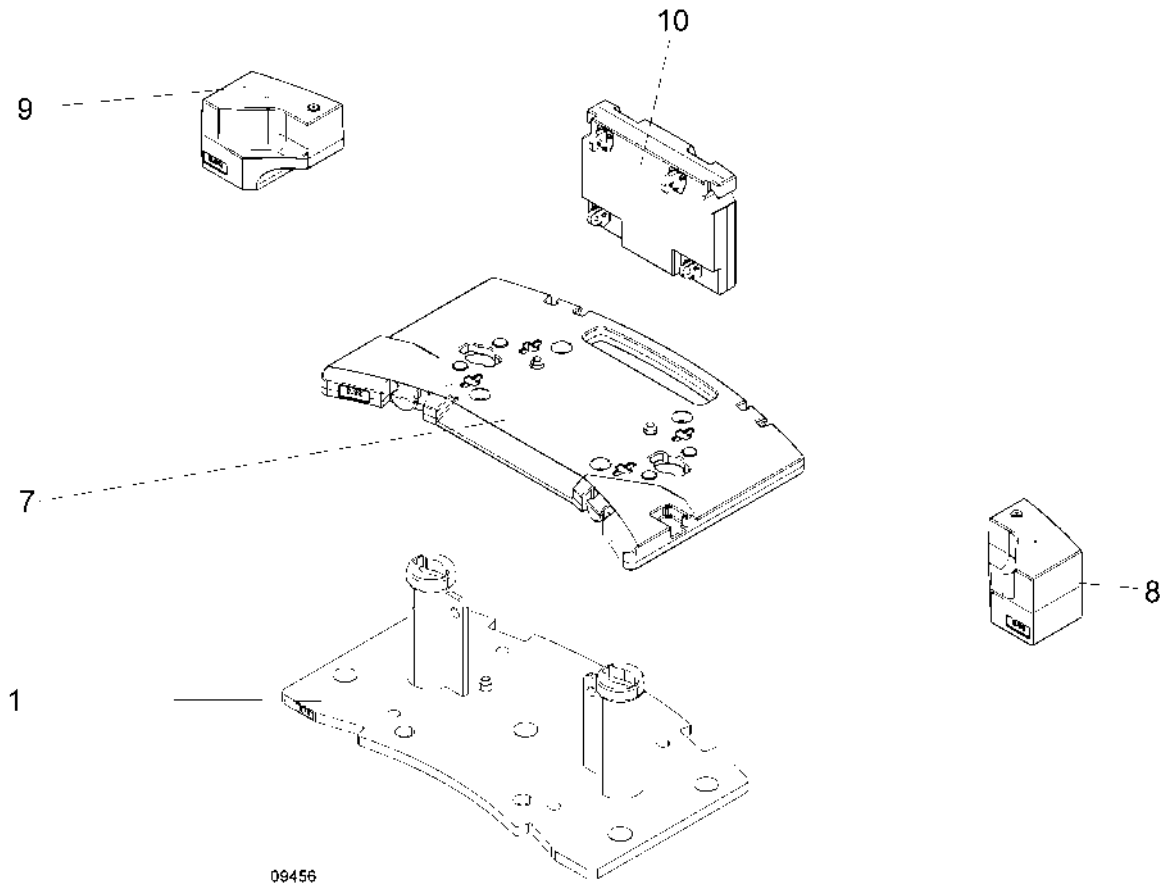

Counterweight variant 6.3 t (13889.1 lbs) comprises:

Base plate 1: 2.4 t (5291.1 lbs)

Counterweight 8: 1.2 t (2645.6 lbs)

Counterweight 9: 1.2 t (2645.6 lbs)

Counterweight 10: 1.5 t (3306.9 lbs)

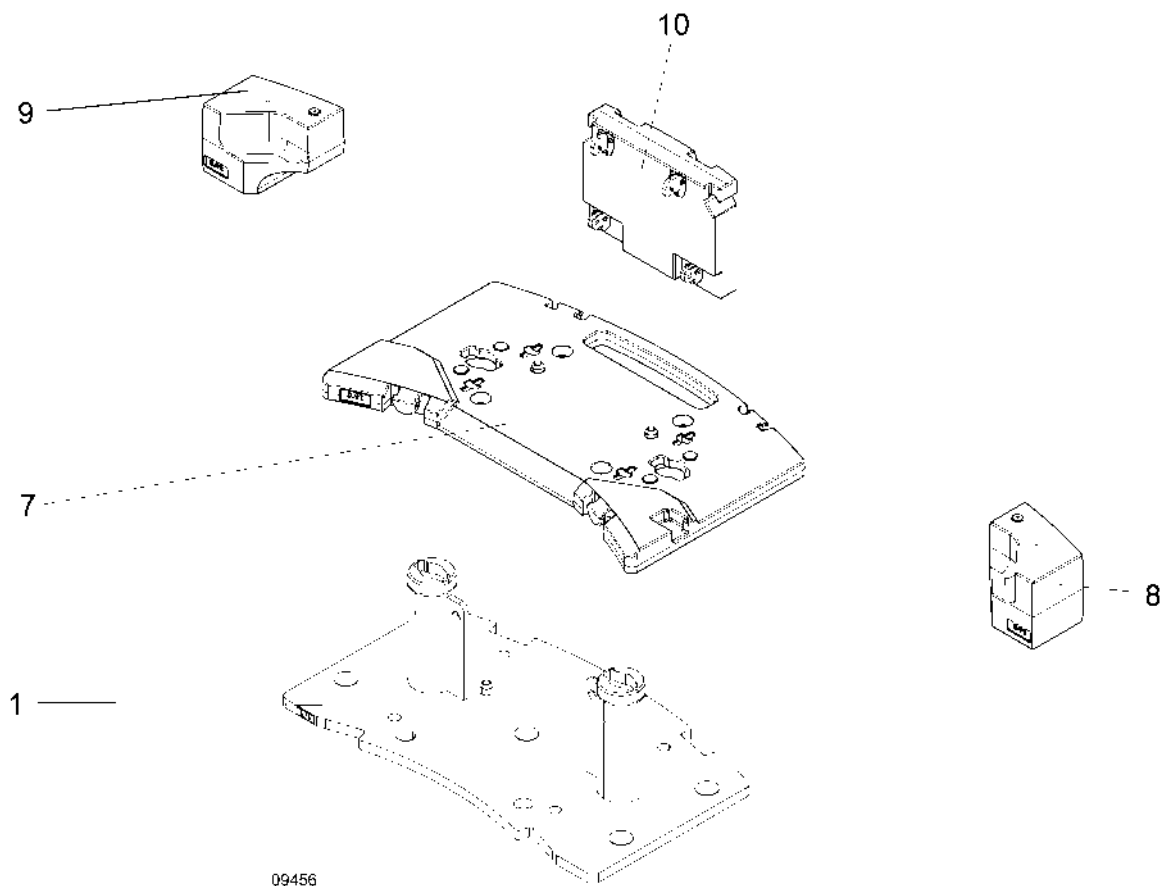
**Counterweight variant 9.4 t (20723.5 lbs)**

Counterweight variant 9.4 t (20723.5 lbs) comprises:

- Base plate 1: 2.4 t (5291.1 lbs)
- Counterweight 7: 3.1 t (6834.3 lbs)
- Counterweight 8: 1.2 t (2645.6 lbs)
- Counterweight 9: 1.2 t (2645.6 lbs)
- Counterweight 10: 1.5 t (3306.9 lbs)

#### Counterweight variant 12.8 t (28219.2 lbs)

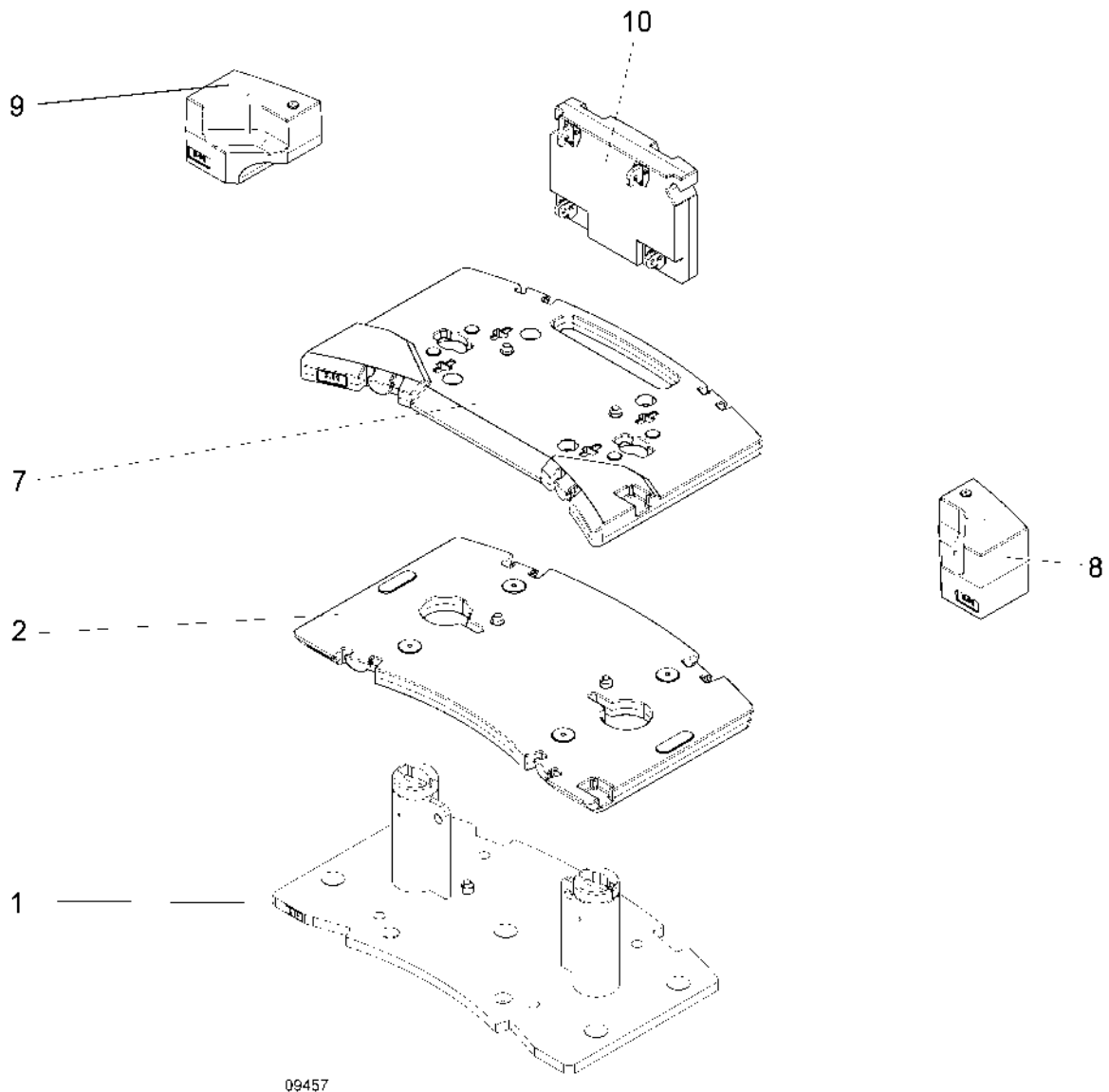

09457

Counterweight variant 12.8 t (28219.2 lbs) comprises:

Base plate 1: 2.4 t (5291.1 lbs)

Counterweight 2: 3.4 t (7495.7 lbs)

Counterweight 7: 3.1 t (6834.3 lbs)

Counterweight 8: 1.2 t (2645.6 lbs)

Counterweight 9: 1.2 t (2645.6 lbs)

Counterweight 10: 1.5 t (3306.6 lbs)

## Counterweight variant 21.7 t (47840.3 lbs)

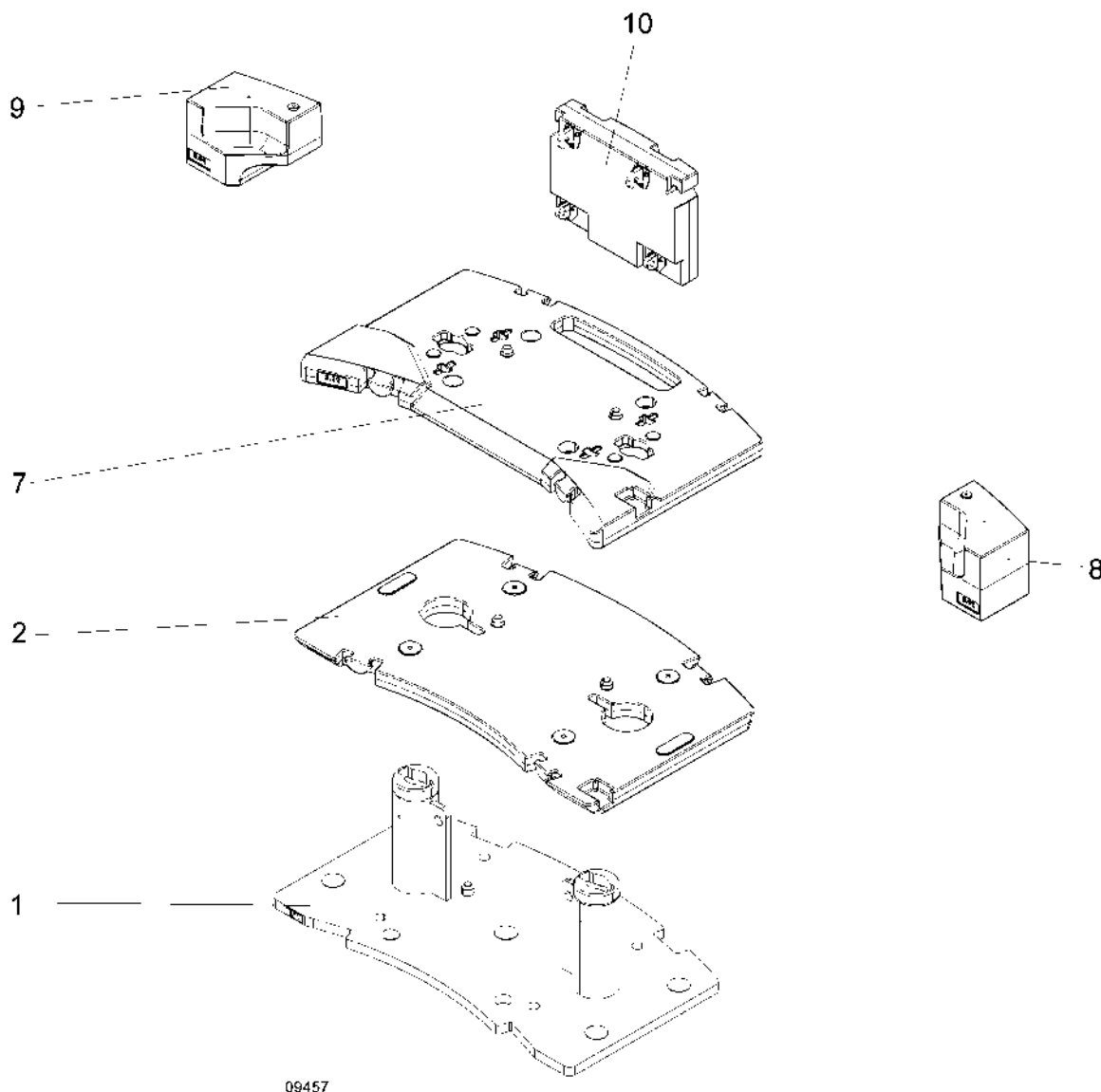

09457

Counterweight variant 21.7 t (47840.3 lbs) comprises:

- Base plate 1: 2.4 t (5291.1 lbs)
- Counterweight 2: 3.4 t (7495.7 lbs)
- Counterweight 3: 8.9 t (19621.1 lbs)
- Counterweight 7: 3.1 t (6834.3 lbs)
- Counterweight 8: 1.2 t (2645.6 lbs)
- Counterweight 9: 1.2 t (2645.6 lbs)
- Counterweight 10: 1.5 t (3306.9 lbs)

Counterweight variant 31.7 t (69886.5 lbs)



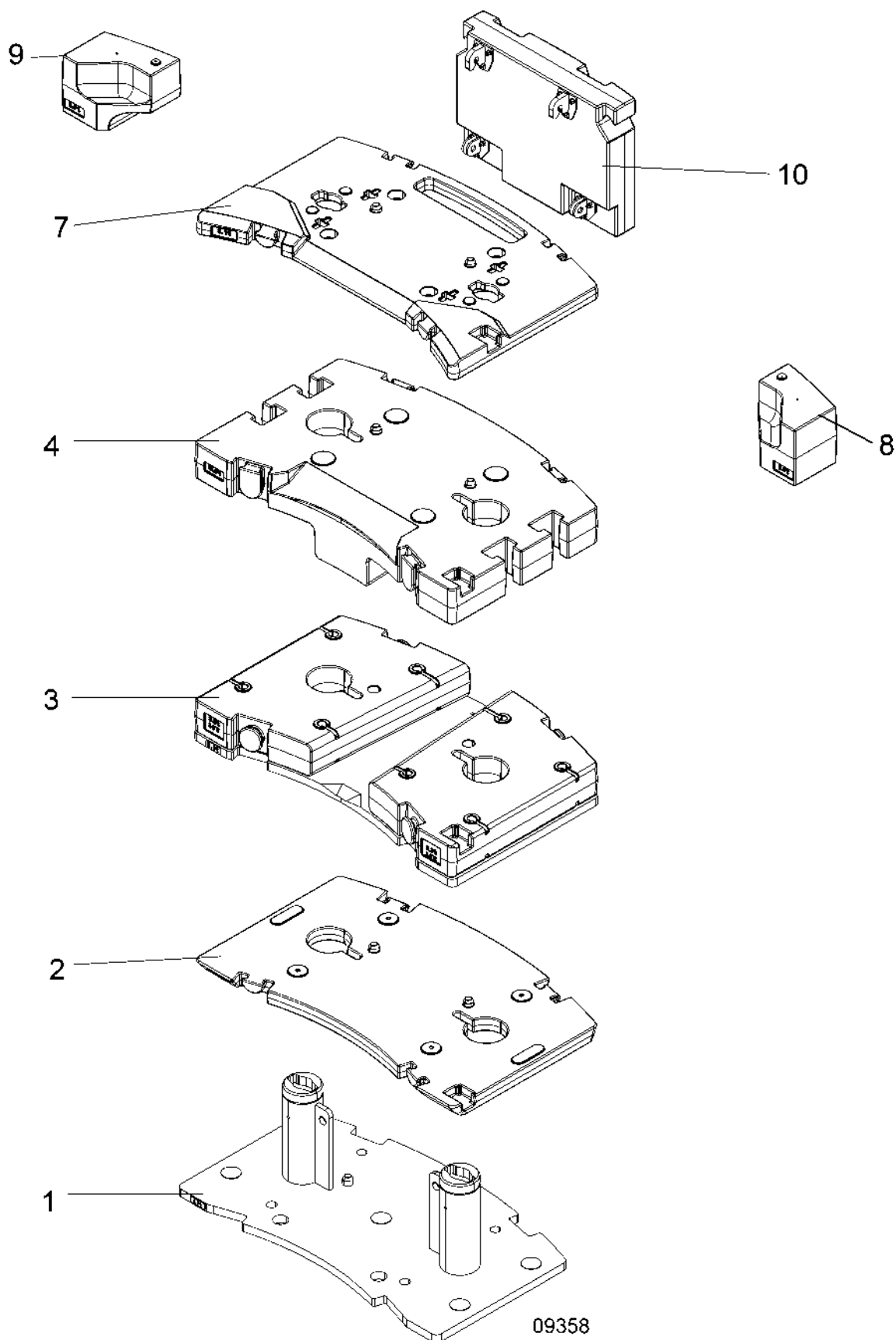

Counterweight variant 31.7 t (69886.5 lbs) comprises:  
Base plate 1: 2.4 t (5291.1 lbs)

Counterweight 2: 3.4 t (7495.7 lbs)  
Counterweight 3: 8.9 t (19621.1 lbs)  
Counterweight 4: 10.0 t (22046.2 lbs)  
Counterweight 7: 3.1 t (6834.3 lbs)  
Counterweight 8: 1.2 t (2645.6 lbs)  
Counterweight 9: 1.2 t (2645.6 lbs)  
Counterweight 10: 1.5 t (3306.9 lbs)

Counterweight variant 42.3 t (93255.5 lbs)

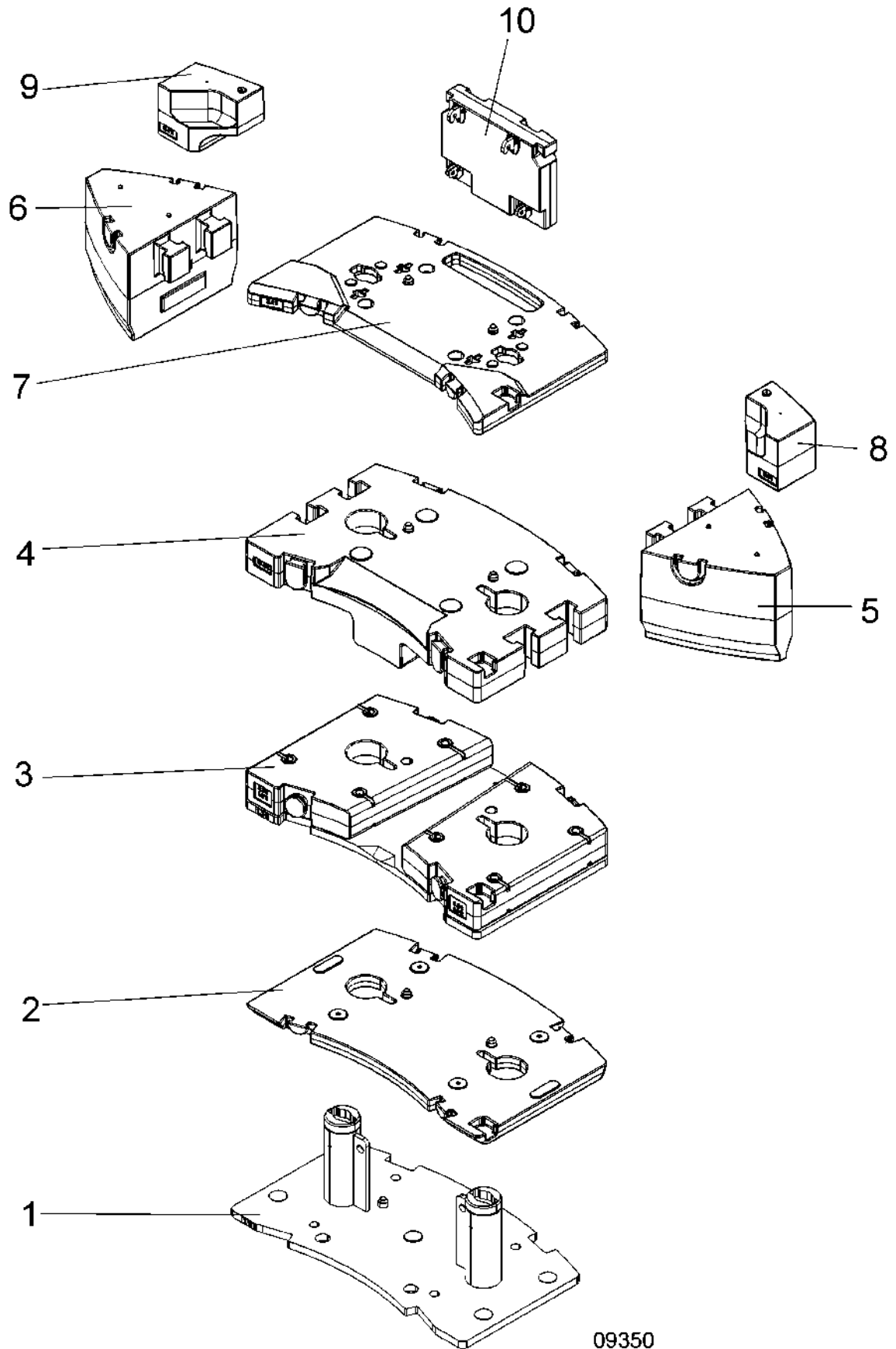

09350

Mounting instruction:



First place the counterweights 2, 3 and 4 on base plate 1.  
Then attach the counterweights 5 and 6 to the right and the left.  
Now attach the counterweight 7.

Counterweight variant 42.3 t (93255.5 lbs) comprises:

Base plate 1: 2.4 t (5291.1 lbs)  
Counterweight 2: 3.4 t (7495.7 lbs)  
Counterweight 3: 8.9 t (19621.1 lbs)  
Counterweight 4: 10.0 t (22046.2 lbs)  
Counterweight 5: 5.3 t (11684.5 lbs)  
Counterweight 6: 5.3 t (11684.5 lbs)  
Counterweight 7: 3.1 t (6834.3 lbs)  
Counterweight 8: 1.2 t (2645.6 lbs)  
Counterweight 9: 1.2 t (2645.6 lbs)  
Counterweight 10: 1.5 t (3306.9 lbs)

### Placing the counterweights in the counterweight storage compartment in the carrier

Separately transported counterweights can be attached to the crane and kept in the counterweight storage compartment of the carrier.

	 <b>WARNING</b>
	<p><b>Danger of accidents due to incorrect operation!</b> Errors when mounting/removing the counterweights may cause accidents.</p> <p>1. Observe the following instructions.</p>

Follow the instructions in the Safety instructions chapters implicitly to avoid accidents.

The mobile crane is supported as prescribed (see the specifications regarding the lifting capacity charts).

Use the prescribed lifting capacity chart for rigging work.

Sling the counterweight elements only at the intended slinging points.

When attaching or removing individual counterweights, there is a risk of getting crushed between the counterweight elements and vehicle parts, especially when slewing the superstructure.

When lifting and lowering the counterweights on the carrier, they should neither be suspended lopsidedly nor oscillate. Risk of accidents as well as damage to vehicle parts.

It is forbidden to remain under swinging counterweights.

Counterweights may be attached only in the illustrated combinations.

Counterweights must be kept safely and securely in the counterweight storage compartment.

Take help of another trained person for keeping individual counterweight elements in the counterweight storage compartment of the carrier. The crane driver must always have eye contact with this person.

Before slewing the superstructure and starting the crane operation, the crane driver must ensure that this person has left the crane and the work area.

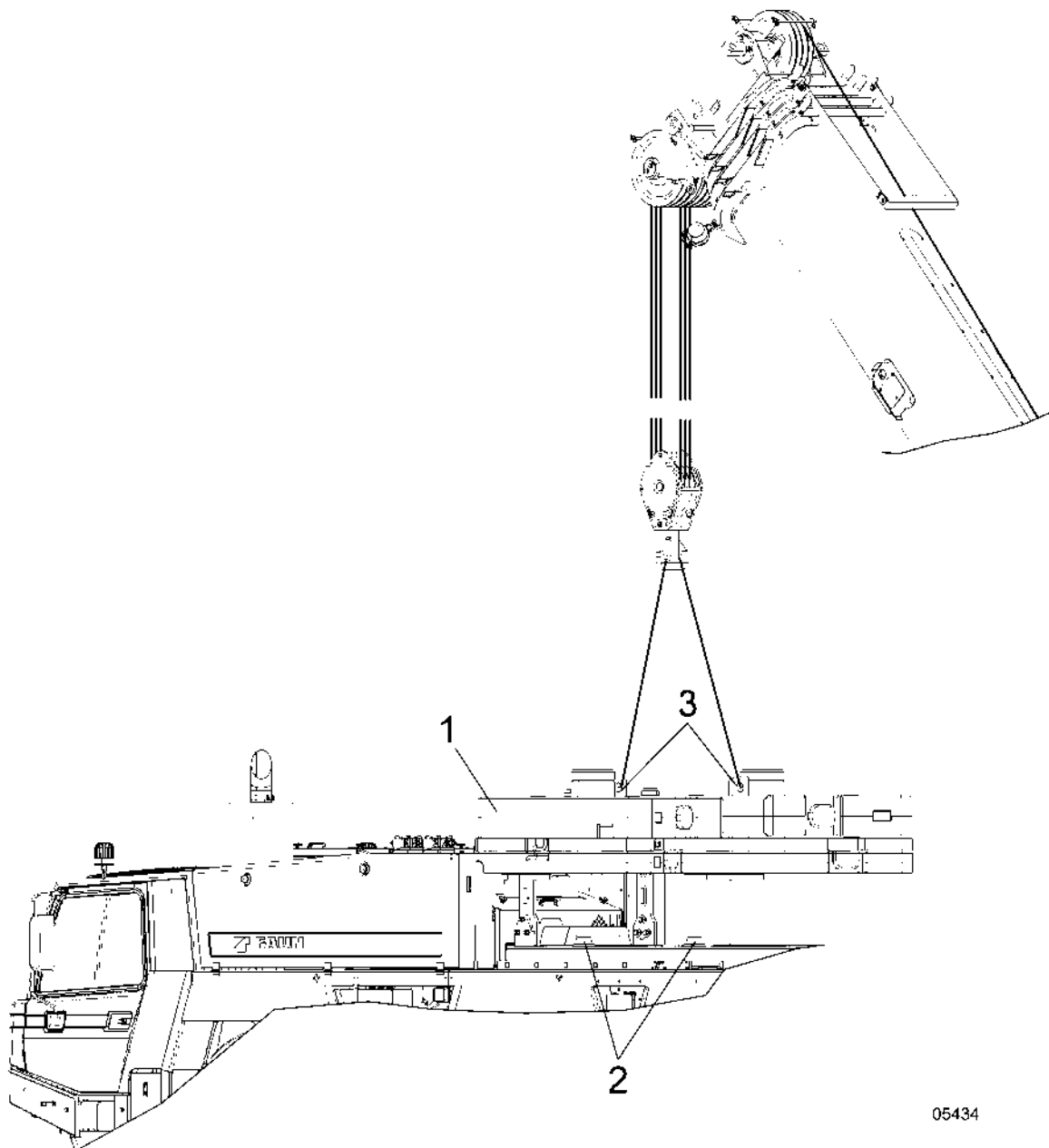

05434

Sling the counterweights (1) to the intended eyelets (3) using the suitable, permitted slinging aids and lift on the carrier.

Carefully lower the counterweights (1) on the carrier as illustrated. Counterweights must slide with the centering holes in the centering pins (2).

#### Attaching and removing the counterweights



#### **! WARNING**

**Danger of accidents due to incorrect operation!**

Errors when mounting/removing the counterweights may cause accidents.

1. Observe the following instructions.

As a rule, ropes may not be loaded beyond their maximum permissible load.

When slinging the ropes, an opening angle of  $120^\circ$  may not be exceeded (the opening angle is the angle between the ropes). The inclination angle is  $60^\circ$  in this case.

At an inclination angle of  $60^\circ$ , the traction force in slinging ropes doubles. In such a case, the ropes must be dimensioned for the double load.

Check the ropes for wear, breakages and strand breakage. Check the rope lock fastener.

Never use old, shortened load ropes as slinging ropes.

In case of sharp-edged loads, always use rope protectors, e.g. wood, to prevent the ropes from damaging.

Precise regulations regarding the intended use and the structural design of ropes to be used in Germany are defined in the "Guidelines for ropes in the operation of hoisting devices".

End joints of ropes must comply with the intended use.

Also observe the legal regulations of the licensing country.

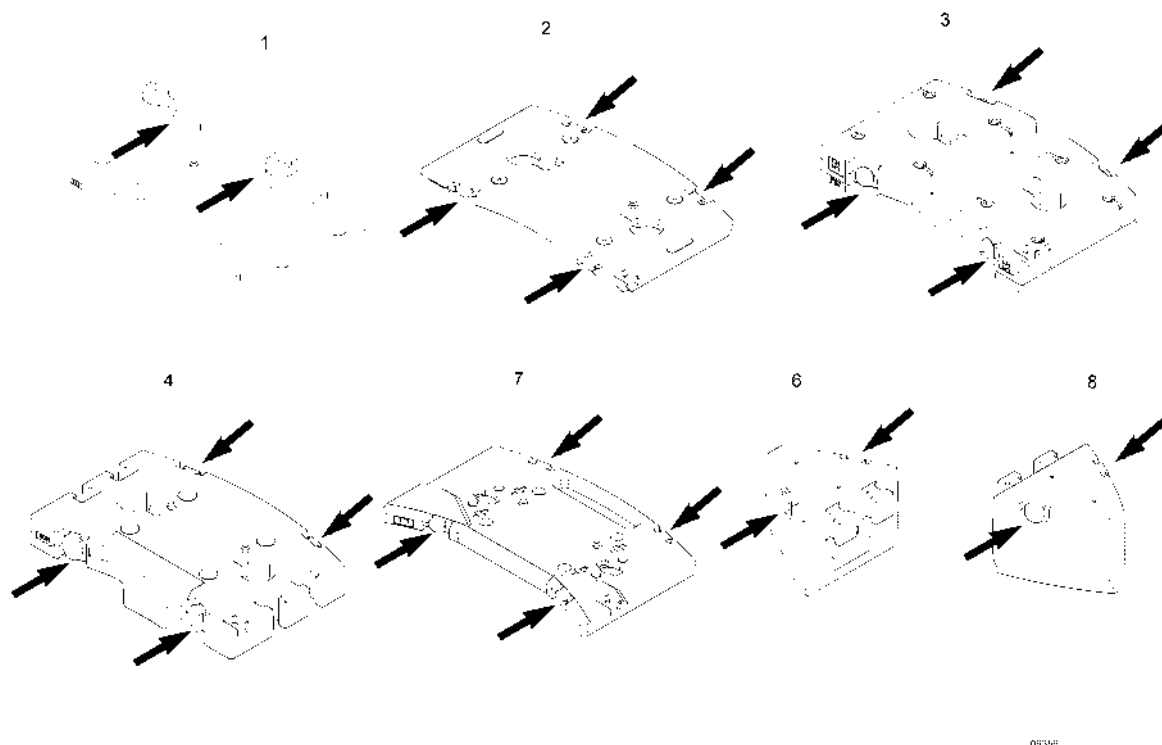

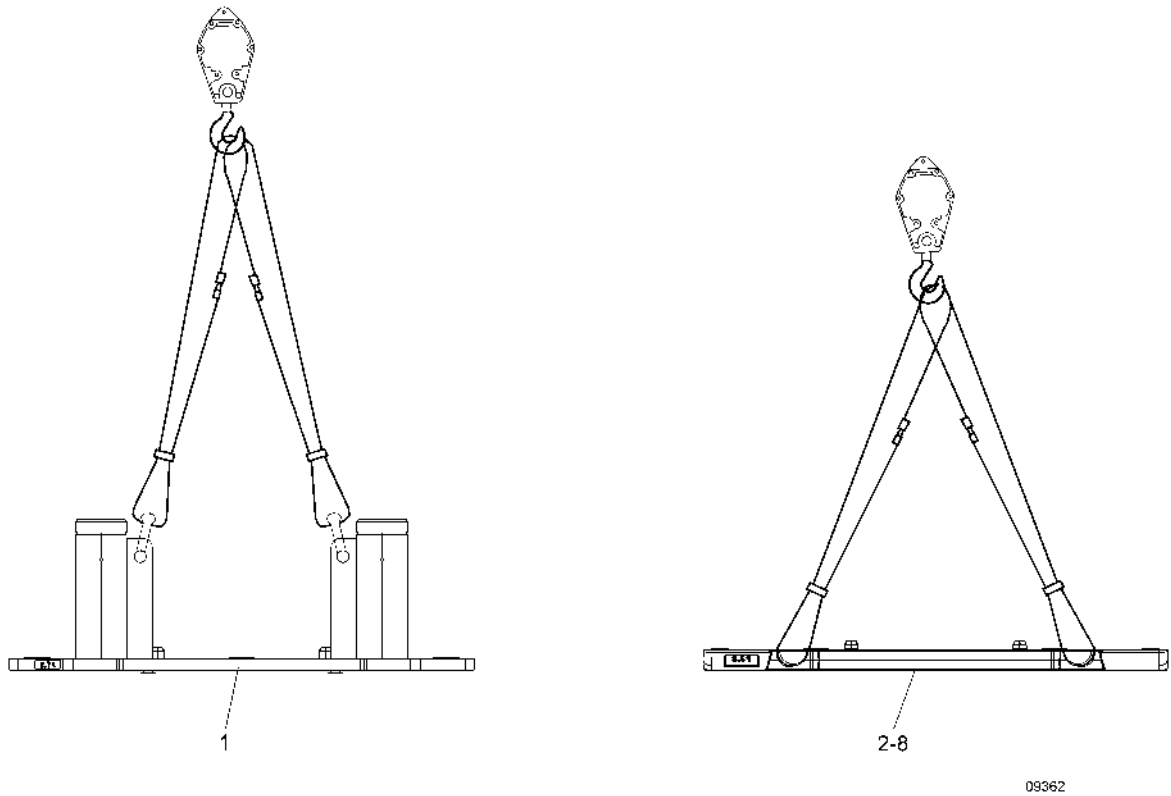

Sling the counterweights and keep them in the counterweight storage compartment of the carrier.  
The arrows indicate the slinging points of individual counterweights.



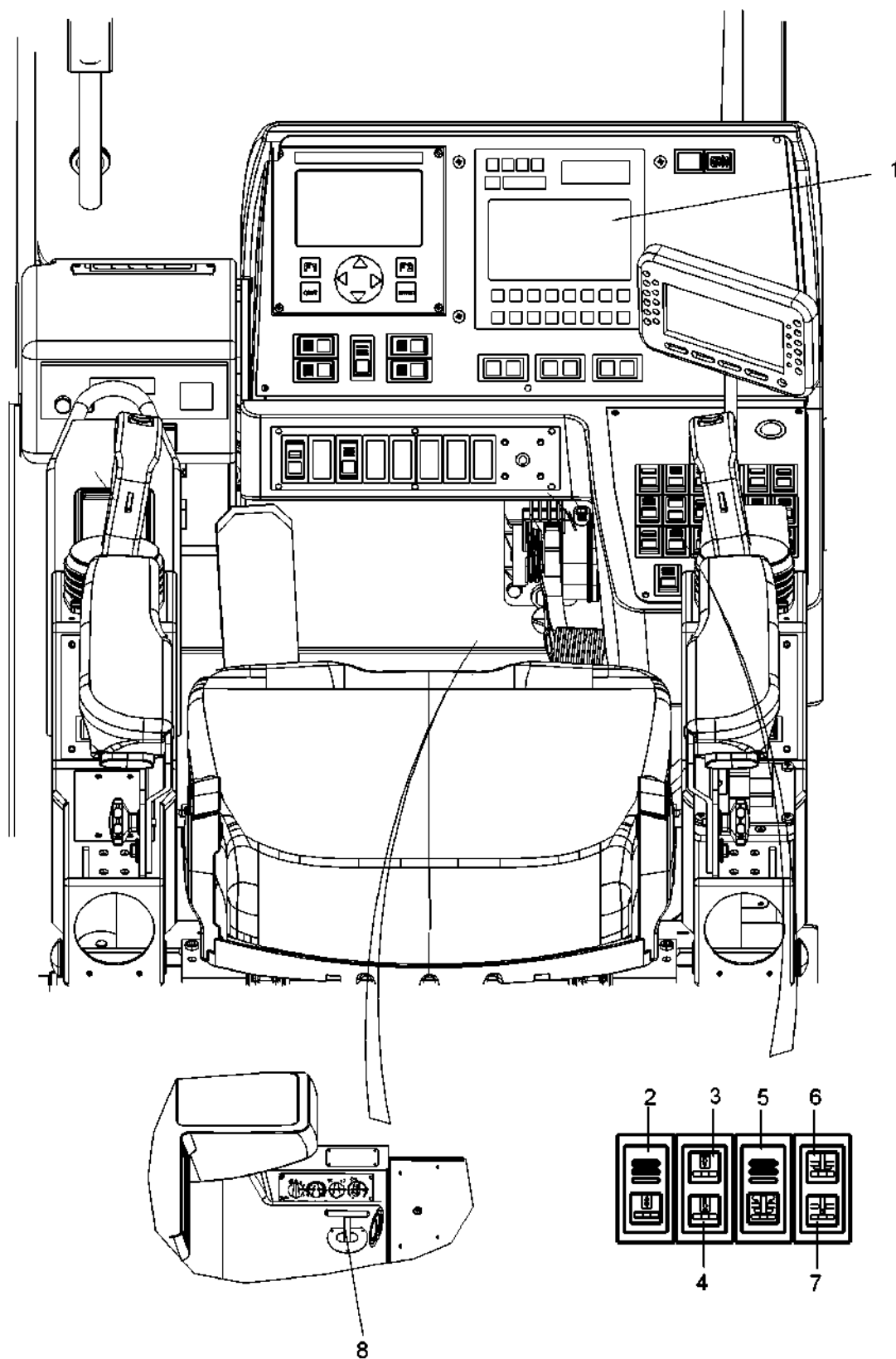

Attaching the counterweights



09377

<p>1 Control device of the automatic safe load indicator</p>	<p>5 Rocker tip switch for locking/unlocking the counterweight</p>
--	--

2	Counterweight up-down rocker tip switch	6	Counterweight locked pilot lamp
3	Counterweight not up warning lamp	7	Counterweight unlocked pilot lamp
4	Counterweight down pilot lamp	8	Superstructure locking bolts

	 <b>WARNING</b>
	<p><b>The counterweight is not up!</b></p> <p>The "Counterweight not up" warning lamp may not light up when operating the crane. If this happens, no slewing movement is possible. Risk of accident!</p> <p>1. Set the "Counterweight up-down" rocker tip switch to the "Up" position and keep it pressed until the counterweight cylinders are completely retracted. The "Counterweight not up" warning lamp must go out. If it lights up again, stop the crane operation immediately, find the cause of the fault and repair it.</p>

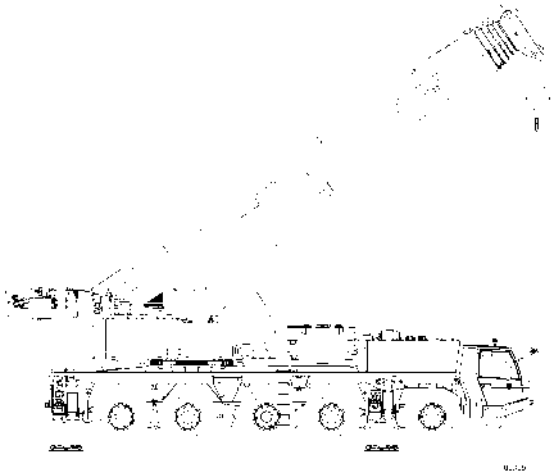
	<p>The mobile crane is supported as described.          The boom is raised as described.          Counterweights are kept in the counterweight storage compartment as described.          The counterweight cylinders are retracted completely.</p>
--	---

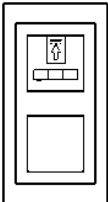
	<p>The counterweight cylinders are retracted completely.          The "Counterweight not up" warning lamp may not light up.</p>
---	---

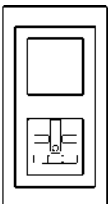
	<p>The "Counterweight unlocked" pilot lamp lights up.</p>
---	---

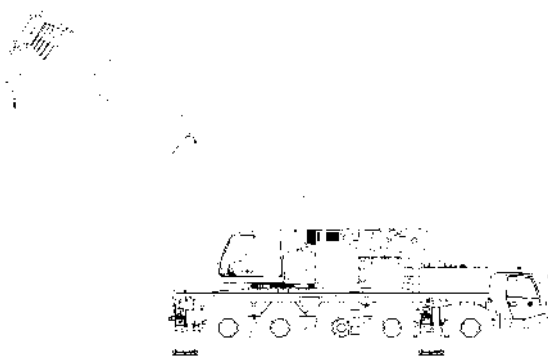
	<p>Slew the superstructure to the back.</p>
---	---

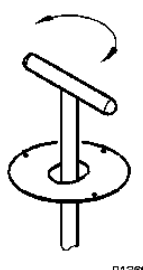
 <p>01360</p>	<p>Press the superstructure locking bolts. The superstructure is mechanically locked.</p>
--	---

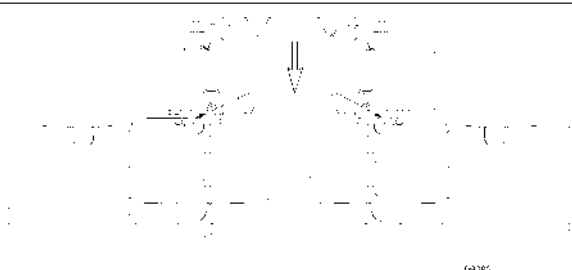
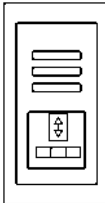
 <p>09382</p>	 <p>Press the "Counterweight up-down" rocker tip switch until the counterweight cylinders are completely extended.</p>
---	--

The 'Counterweight not up' warning lamp lights up when extending

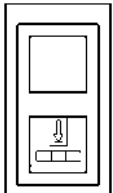
	<p>If the counterweight cylinders have been extended, the "Counterweight down" pilot lamp lights up. This is a prerequisite for locking the counterweight.</p>
---	--

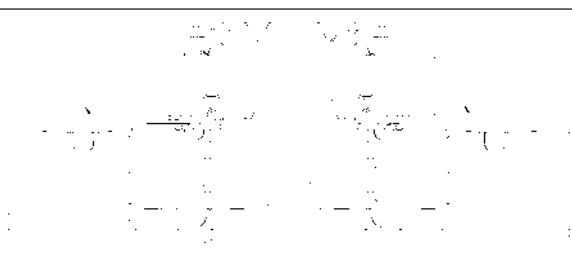
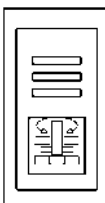
 <p>09382</p>	 <p>Press the "Counterweight lock-unlock" rocker tip switch until the counterweight is locked.</p>
--	---

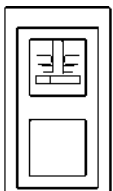
	<p>The "Counterweight locked" pilot lamp lights up as soon as the counterweights are locked.</p>
---	--

At the same time, the "Counterweights unlocked" pilot lamp goes out.

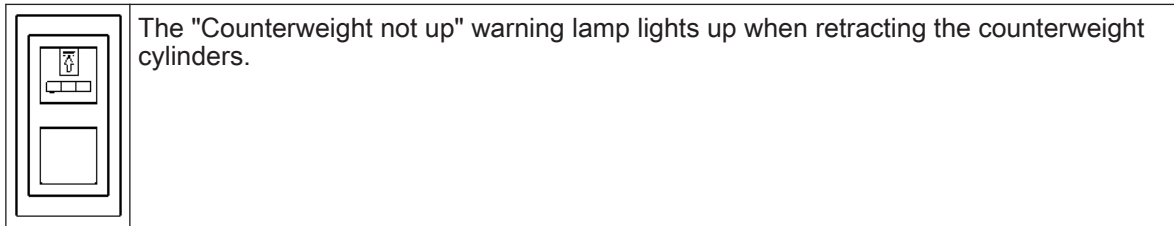
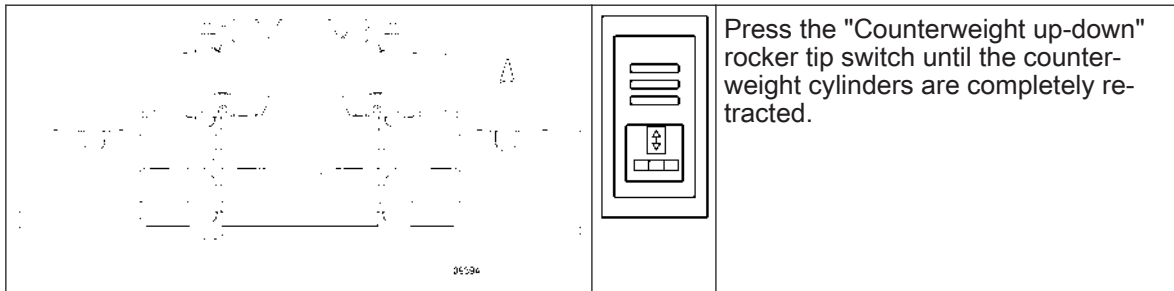

The "Counterweight down" pilot lamp goes out.

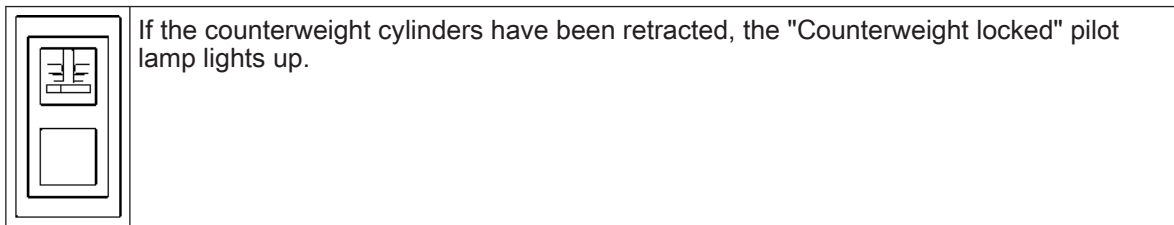

The "Counterweight not up" warning lamp does not light up as long as the counterweight is completely up and locked.

Counterweights are stored and removed in the logical reverse order.

#### Counterweight division/rig arrangement

The mobile crane may be driven only with the rig arrangements listed below. Deviating rig arrangements are possible only after consulting and approval of the vehicle manufacturer.

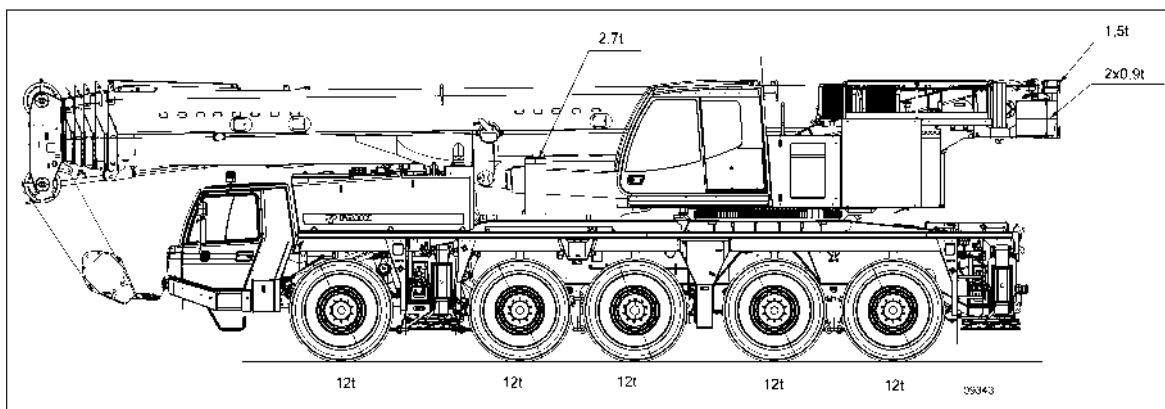

Model	Counterweight (t (lbs))				Remarks
	total	Stowed at front	Mounted at back	Transport vehicle	
With driver 63 t (138891.2 lbs) bottom block attached Tires 445/95 R25 (16.00 R 25) 10x8 drive With jib 10 t (22046.2 lbs) hook tackle in the rack	6.3 t (13889.1 lbs)	2.4 t (5291.1 lbs)	2 x 1.2 t (2645.6 lbs)	36 t (79366.4 lbs)	
1.5 t (3306.9 lbs)					
	6.3 t (13889.1 lbs)				

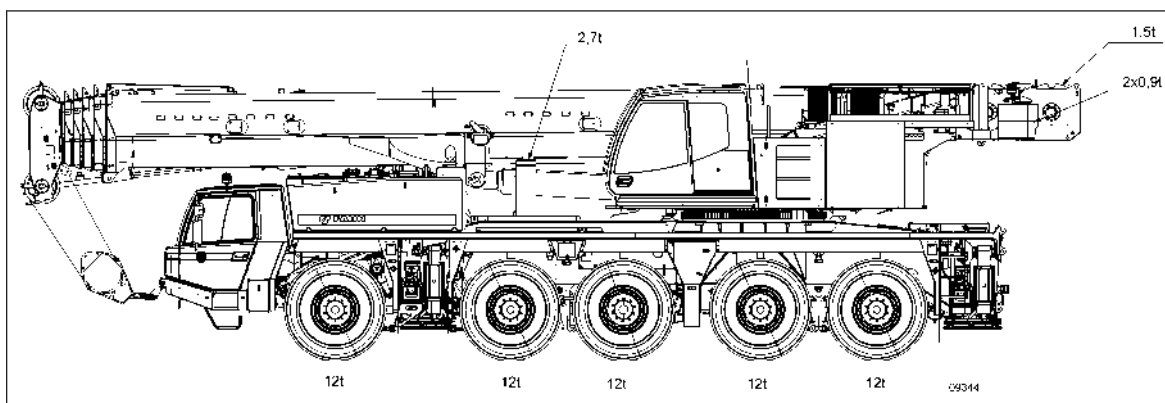

Model	Counterweight (t (lbs))				Remarks
	total	Stowed at front	Mounted at back	Transport vehicle	
With driver 63 t (138891.2 lbs) bottom block attached Tires 445/95 R25 (16.00 R 25) 10x8 drive With jib 10 t (22046.2 lbs) hook tackle in the rack 2nd hoisting gear	6.3 t (13889.1 lbs)	2.4 t (5291.1 lbs)	2 x 1.2 t (2645.6 lbs)	36 t (79366.4 lbs)	
2nd hoisting gear					
	6.3 t (13889.1 lbs)				

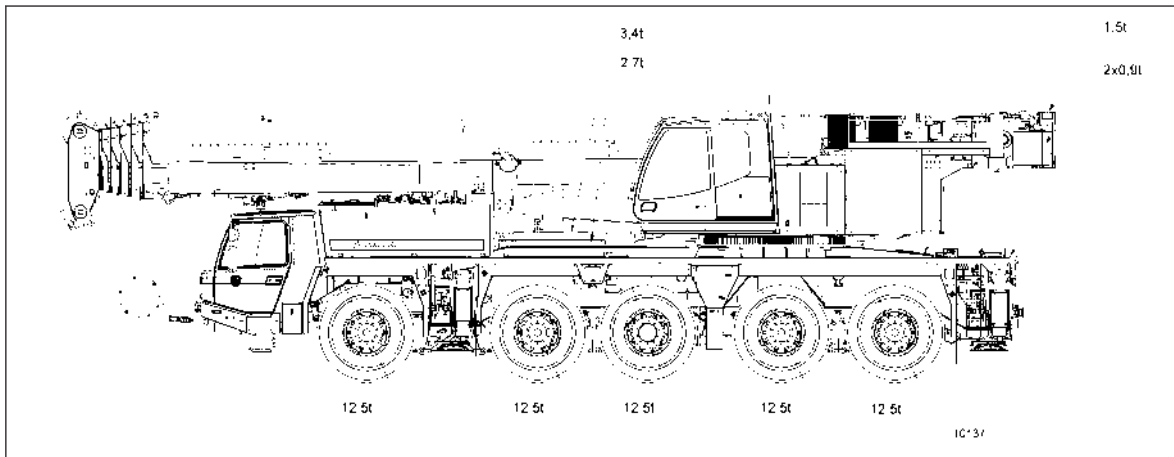

Model	Counterweight (t (lbs))				Remarks
	total	Stowed at front	Mounted at back	Transport vehicle	
With driver 63 t (138891.2 lbs) bottom block attached Tires 445/95 R25 (16.00 R 25) 10x8 drive Without jib	9.7 t (21384.8 lbs)	2.4 t (5291.1 lbs)	2 x 1.2 t (2645.6 lbs)	32.6 t (71870.7 lbs)	
3.4 t (7495.7 lbs)		1.5 t (3306.9 lbs)			
9.7 t (21384.8 lbs)					

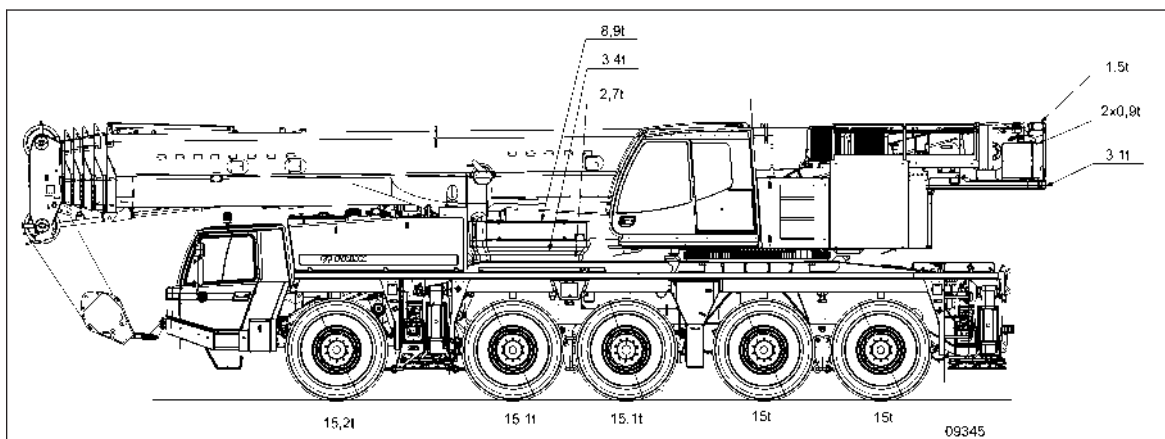

Model	Counterweight (t (lbs))				Remarks
	total	Stowed at front	Mounted at back	Transport vehicle	
With driver 63 t (138891.2 lbs) bottom block attached Tires 445/95 R25 (16.00 R 25) 10x8 drive With jib 10 t (22046.2 lbs) hook tackle in the rack	21.7 t (47840.3 lbs)	2.4 t (5291.1 lbs)	2 x 1.2 t (2645.6 lbs)	20.6 t (45415.2 lbs)	
3.4 t (7495.7 lbs)		1.5 t (3306.9 lbs)			
8.9 t (19621.1 lbs)		3.1t (6834.3 lbs)			
		21.7 t (47840.3 lbs)			

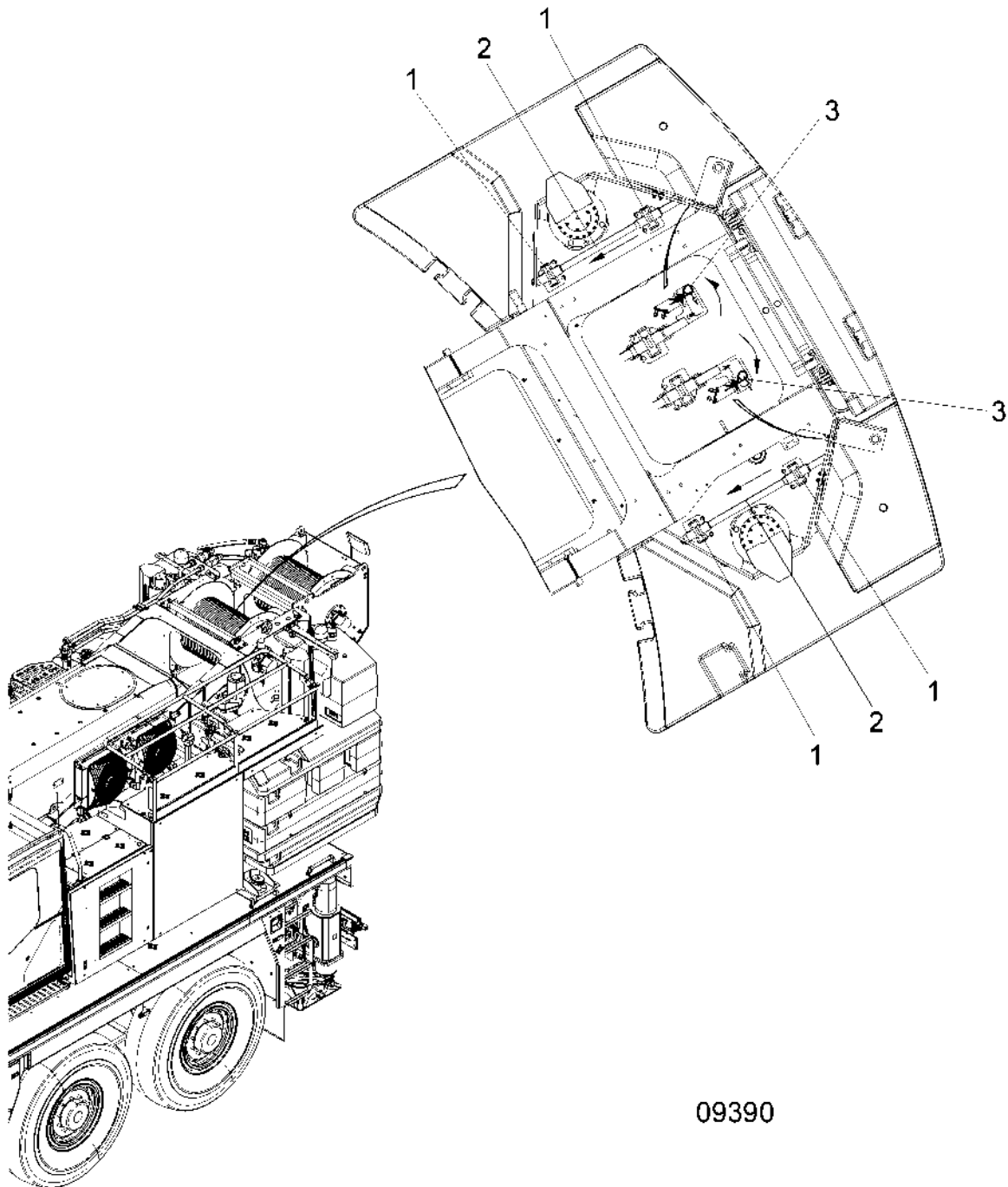

3.1 t (6,834.3 lbs) counterweight mounted on the superstructure\*)



09390

1	Eyelets	3	Spring clip
2	Holding bar		



	 <b>WARNING</b>
	<p><b>Counterweight is not mounted correctly.</b></p> <p>The counterweight may come off and fall from the superstructure. Risk of accident!</p> <p>1. Check all fastening parts before mounting. Do not use defective parts. After mounting the counterweight, check it for firmness.</p>

Prerequisite:

The mobile crane is supported.

The 21.7 t (47,840.3 lbs) or lower counterweight variant kept in the counterweight storage compartment.

4 units. Eyelets are mounted on the 3.1 t (6,834.3 lbs) counterweight.

Mount the counterweight on the superstructure:

Do not slew the mobile crane to the back.

Lock the superstructure.

Attach the counterweights.

Guide the holding bars through eyelets.

Slew the holding bars by 90°.

Secure the holding bars using spring clips.

Release the counterweight.

Check the counterweight for correct fit.

The 3.1 t (6,834.3 lbs) counterweight is firmly mounted on the superstructure.

### **Bolting the 3.4 t (7,495.7 lbs) and 8.9 t (19,621.1 lbs) counterweights with one another**

The 3.4 t (7,495.7 lbs) and 8.9 t (19,621.1 lbs) counterweights can be bolted with one another. Use the screws provided with the mobile crane for this purpose.

### **3.10.2 Jib\*)**

The section below illustrates and describes both the mechanical angling (standard equipment) and hydraulic angling (optional) of the jib.

#### **Mechanically angled fly jib**

The fly jib consists of 3 parts and can be extended with max. 2 intermediate pieces.

The fly jib can be angled to 3 angle settings.

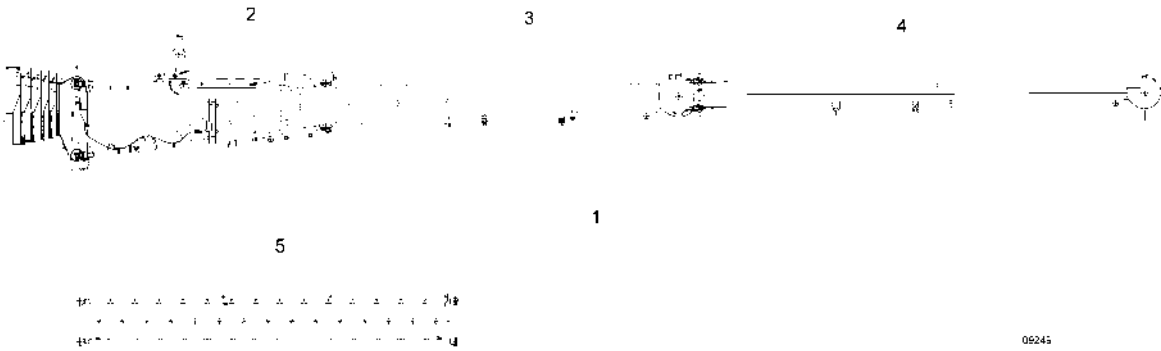

1	3-piece fly jib, 18 m (59.1 ft)	4	7.5-m-boom tip (24.6 ft)
2	3.8-m-fly jib (12.5 ft)	5	7.0-m-intermediate section (23.0 ft)
3	6-m-stinger foot (19.7 ft)		

**DANGER**

**Danger due to falling jib!**

An incorrectly bolted jib may come off and fall on the ground. Persons under or in the range of the jib may get injured.

1. Always ensure that all lock pins, retaining pins and swivel pins are in the prescribed positions.
2. Ensure that nobody is present in the slewing range of the jib when carrying out rigging work.

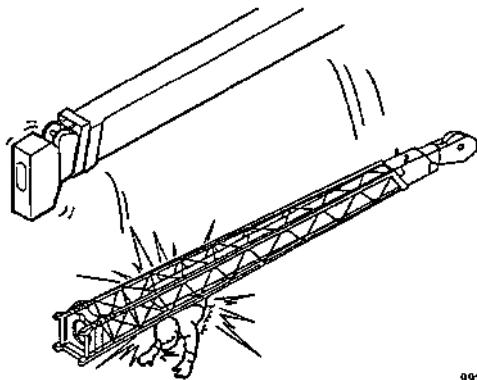



99127

**WARNING**

**Risk of falling!**

When working at heights, installation personnel may fall and be seriously or fatally injured.

1. Make sure that personnel cannot fall with suitable aids for installation and dismantling work (e.g. work platform, railing).
2. Use the available access steps and double ladder that are provided.

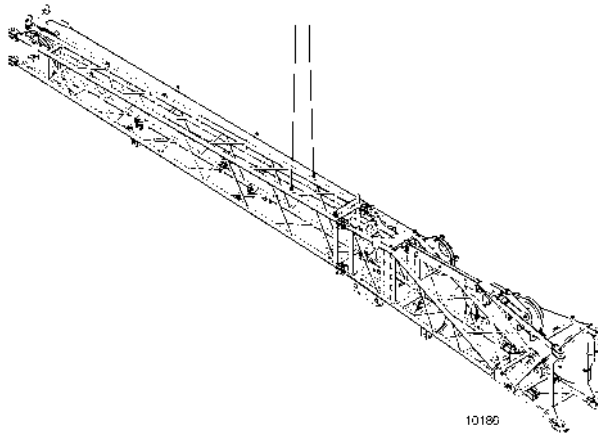

	<p><b>⚠ WARNING</b></p> <p><b>Risk of skidding and accident!</b> When climbing and stepping on ladders and access ladders, take utmost care especially in case of humid weather.</p> <ol style="list-style-type: none"> <li>1. Always keep the ladders and access ladders clean.</li> <li>2. Remove dirt and other greasy substances immediately and thoroughly.</li> <li>3. Always hold the ladder beams or handles while climbing up or down.</li> <li>4. Wear non-slip shoes and keep them clean.</li> <li>5. Ensure that the ladders are safe.</li> </ol>
	<p><b>⚠ DANGER</b></p> <p><b>Overloading of the mobile crane!</b> Lifting the loads on the ground by raising the boom can lead to boom overload or can also cause the crane to tilt. Raising movements are not switched off via the automatic safe load indicator.</p> <ul style="list-style-type: none"> <li>▶ Loads may not be dragged.</li> </ul> <ol style="list-style-type: none"> <li>1. Carry out load movements only using the hoisting winch.</li> <li>2. Lift the loads only vertically.</li> </ol>
	<p><b>NOTICE</b></p> <p><b>Slewing range too small!</b> If the slewing range of the jib has buildings, trees or other obstacles, collisions may occur when slewing and it will lead to damage.</p> <ol style="list-style-type: none"> <li>1. Select a suitable location for mounting the jib.</li> </ol>
<p><b>i</b></p>	<p>When operating the crane with the jib folded in the transport position on the boom or when working using the boom with the attached jib, the bearing loads specified in the lifting capacity charts are reduced by the values specified in the notes regarding the lifting capacity charts.</p>
<p><b>i</b></p>	<p>The automatic safe load indicator has a setup mode for installing and dismantling the jib. In this setup mode, the anti-twoblock device has automatic bridging. The operation should be carried out in unloaded condition and with utmost care.</p>
<p><b>i</b></p>	<p>The slewing range is increased after mounting the jib.</p> <ol style="list-style-type: none"> <li>1. Attach the counterweights in advance.</li> </ol>

### Sling points on fly jib

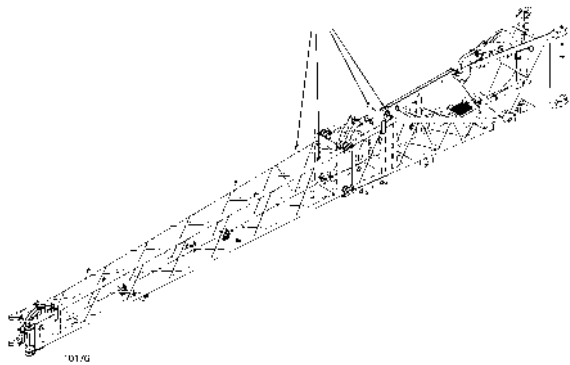
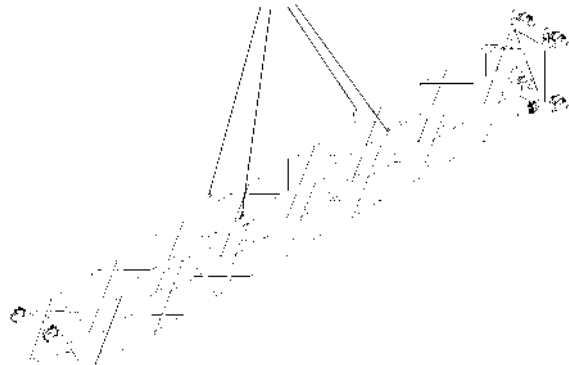
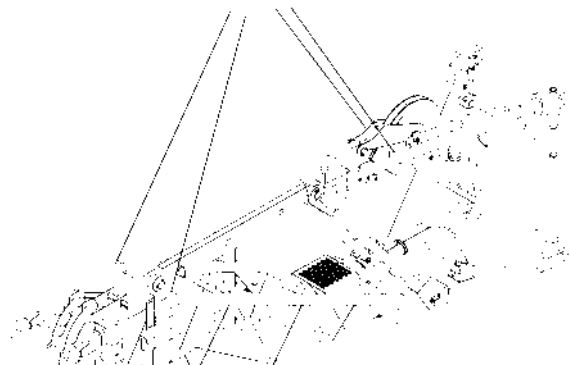
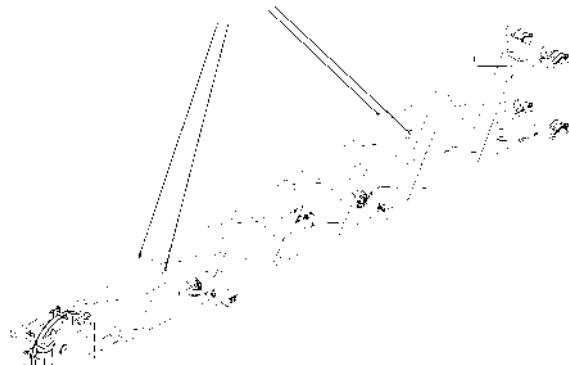
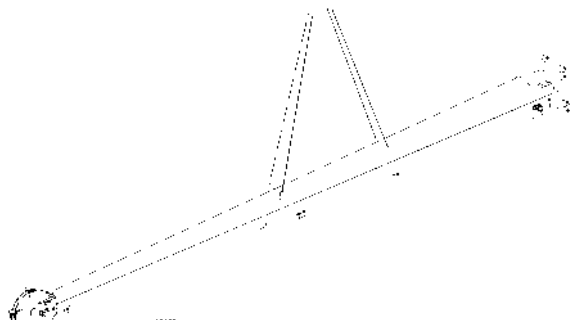

3-piece fly jib, 18 m (59.1 ft) (approx. 1610 kg (3549.5 lbs)).  
Suitable slinging aids: Chains or ropes.

 <p>1</p>	 <p>2</p>
 <p>3</p>	 <p>4</p>
 <p>5</p>	
<p>1 2-piece stinger, 10 m (32.8 ft) (approx. 1190 kg (2623.5 lbs))</p>	<p>2 7-m-intermediate section (23.0 ft) (approx. 480 kg (1058.2 lbs))</p>
<p>3 3.8-m-fly jib (12.5 ft) (approx. 730 kg (1609.4 lbs))</p>	<p>4 6-m-fly jib foot (19.7 ft) (approx. 460 kg (1014.2 lbs))</p>
<p>5 7.5-m-boom tip (24.6 ft) (approx. 420 kg (926.0 lbs))</p>	

	<p><b>⚠ DANGER</b></p> <p><b>Incorrect slinging aids used!</b></p> <p>The jib may fall on the ground if unsuitable slinging aids are used. This may damage the jib. Persons under the jib may get injured.</p> <p>1. Fix a suitable slinging aid to the lifting lugs of the stinger.</p>
	<p><b>⚠ DANGER</b></p> <p><b>Incorrect slinging points used!</b></p> <p>If the wrong slinging points are used, the jib may become unstable. This may damage the jib. Persons under the jib may get injured.</p> <p>1. Use the specified attachment points when attaching the jib.</p>

**Description of remote control**

The telescopic boom is equipped with a hydraulic folding aid and a hydraulic locking bolt for the jib. A remote control is used for controlling them.

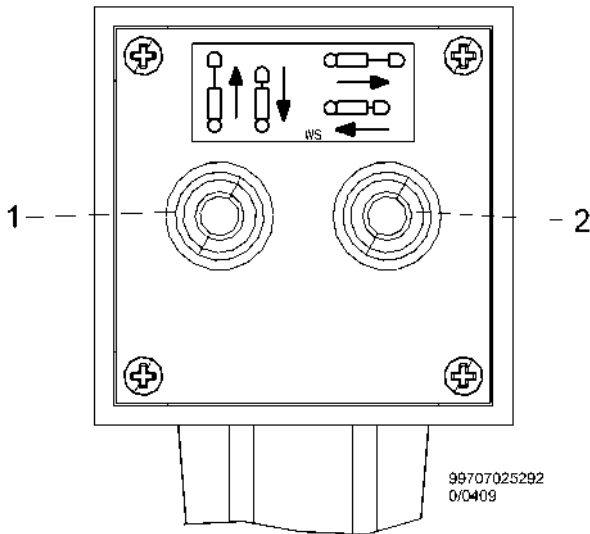

<p>1 Lock/unlock connecting bolt: Lever to the front: lock the connecting bolt Lever to the back: unlock the connecting bolt</p>	<p>2 Retract/extend slewing cylinder: Lever to the front: extend the slewing cylinder Lever to the back: retract the slewing cylinder</p>
--	---

### Connecting the remote control

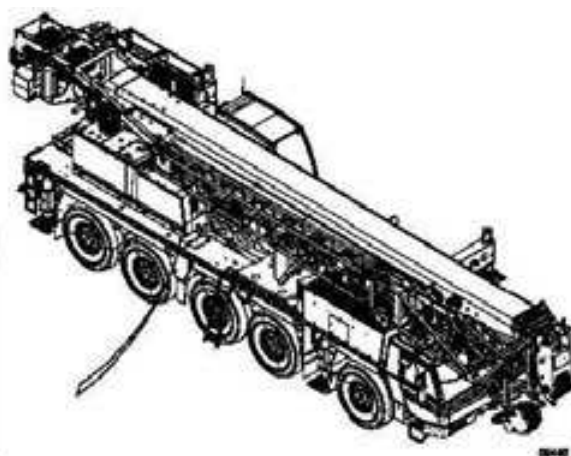

1. Connect the remote control at the front-right on the superstructure.

### Working with the 18-m-stinger foot (59.1 ft)

The following section describes the structure of the 3-piece fly jib, i.e. the 3.8-m-fly jib (12.5 ft), the 6.0-m-fly jib foot (19.7 ft) and the boom tip.

#### Requirements

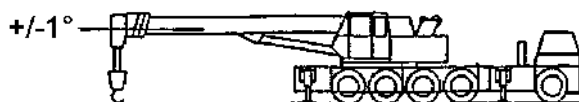

- The mobile crane is supported as prescribed.
- Counterweights required for the crane operation are attached.
- The slewing gear brake is engaged.
- All telescopes are retracted.
- The superstructure is slewed to the back or side.
- The telescopic boom is set horizontally ( $\pm 1^\circ$ ).

**⚠ WARNING!** In case of larger angles, there is a risk of accident and personal injuries.



09412

- The stinger (3-piece) is mounted at the transport position on the telescopic boom.
- The bottom block was placed on the ground and decoupled. The rope clamp and the release weight of the anti-twoblock device were removed from the hoisting rope. **NOTICE!** This point is not necessary for crane work using hoisting gear 1 via the boom head or hoisting gear 2 via the jib.
- The double ladder, crank handle and the remote control for the slewing cylinder are ready.

	 <b>WARNING</b>
	<p><b>Risk of skidding and accident!</b></p> <p>When climbing and stepping on ladders and access ladders, take utmost care especially in case of humid weather.</p> <ol style="list-style-type: none"><li>1. Always keep the ladders and access ladders clean.</li><li>2. Remove dirt and other greasy substances immediately and thoroughly.</li><li>3. Always hold the ladder beams or handles while climbing up or down.</li><li>4. Wear non-slip shoes and keep them clean.</li><li>5. Ensure that the ladders are safe.</li></ol>

### Bringing the fly jib into the working position

#### Preparations

1. Switch on the battery main switch and the ignition in the crane cab. Start the superstructure engine.

2. Activate the  setup mode in the automatic safe load indicator.

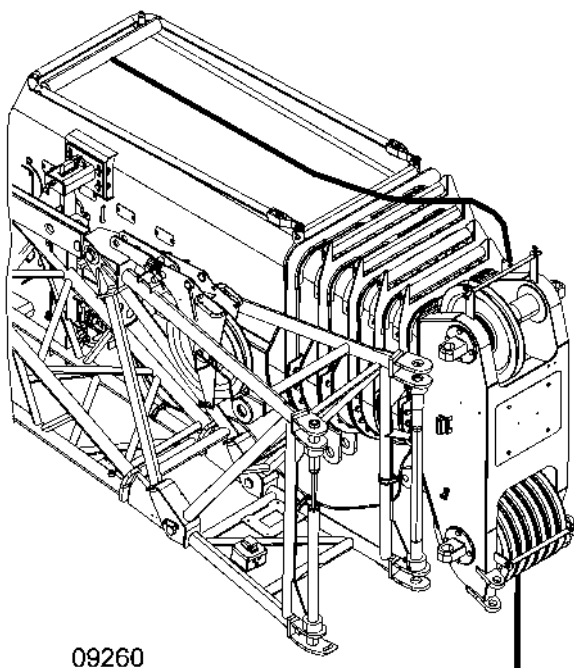

3. Wind/unwind the hoisting rope until the rope end projects above the boom head and stow it to the side. **NOTICE! Do not drag the hoisting rope on the ground.**



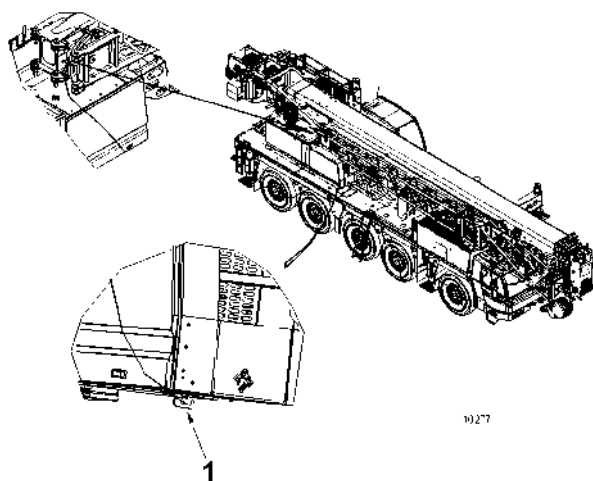

4. Fix the guide belt on the 6.0-m-stinger foot (19.7 ft). Secure the other end of the guide belt to the superstructure (1) to prevent the fly jib from pivoting out uncontrollably.

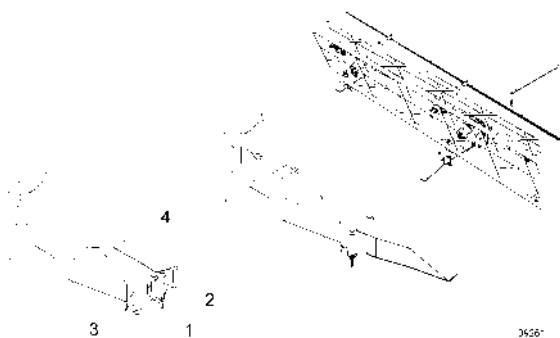

5. Fold out the transporting support. Remove the folding plug (1) and pull the bolt (2) downwards. Fold out the transporting support extension (4), insert the bolt (2) in the hole (3) from bottom and secure using the folding plug (1).
6. Connect the remote control.

### Pivoting the fly jib to the boom head

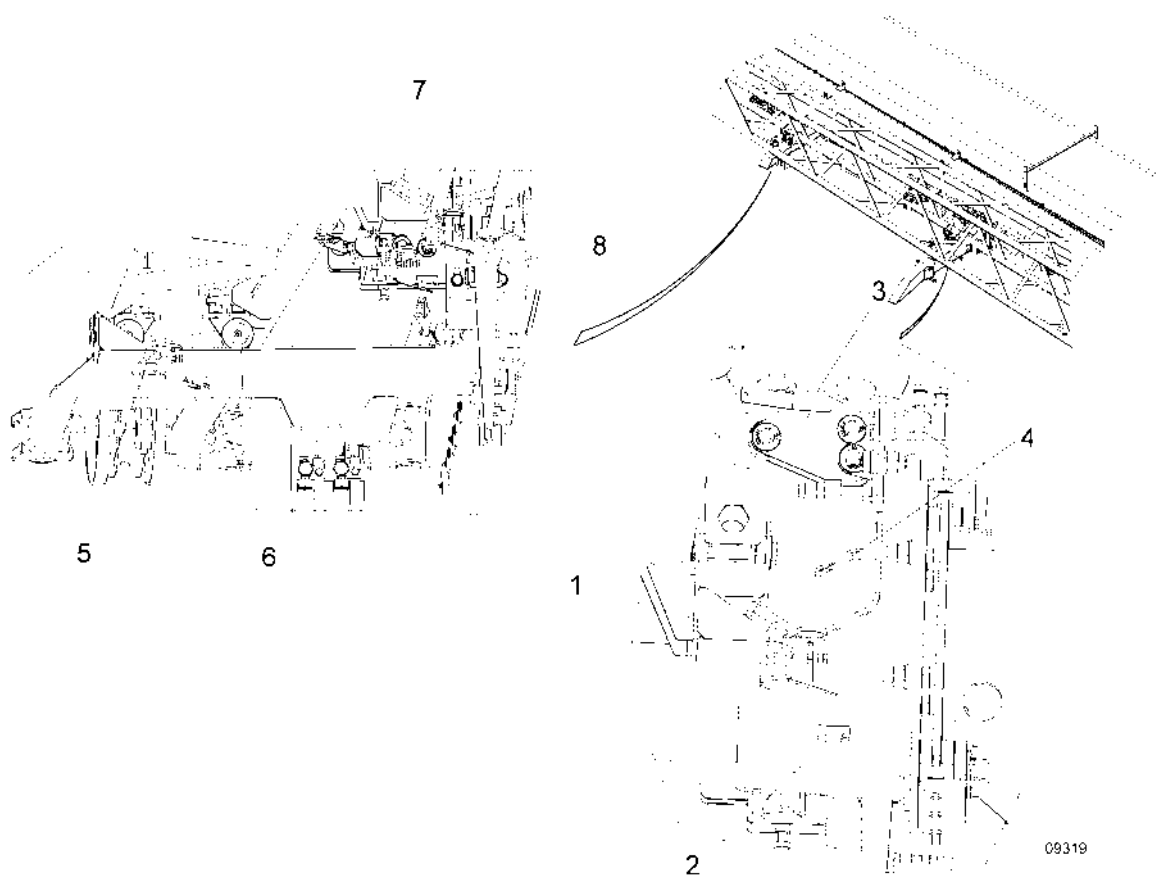

1. Loosen the pins (1) and (3) on the **middle** transporting support.  
Pull the spring clip and the locking pin, insert in the pin holder (2) or (4) and secure again using the spring clip.
2. Loosen the pins (5) and (7) on the **rear** transporting support.  
Pull the spring clip and the locking pin, insert in the pin holder (6) or (8) and secure again using the spring clip.
3. Extend the slewing cylinder using the remote control (right lever forwards) until the holes on the 3.8-m-fly jib (12.5 ft) are flush with the holes on the right-hand side of the boom head.

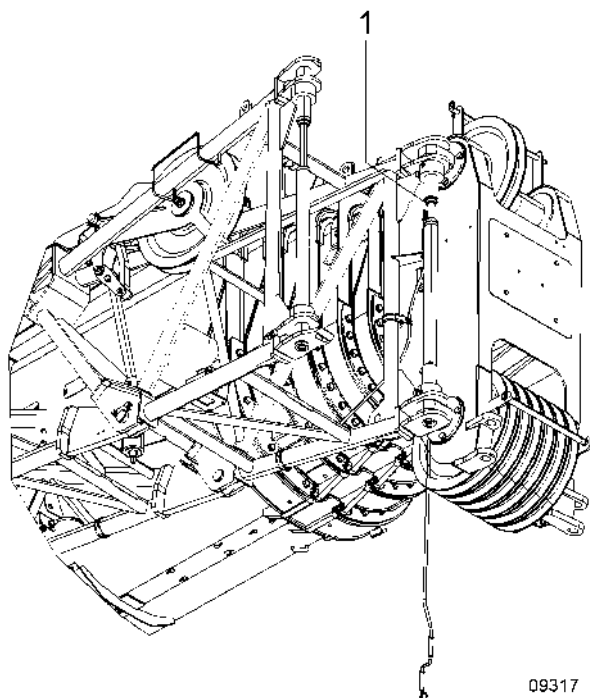

4. Insert the crank handle into the threaded bolt and turn until the third red marking (1) is completely visible. **⚠️ WARNING!** The upper and lower bolt elements must be retracted completely (up to the end stop) in the bearing brackets on the boom head. Since both bolt ends are not retracted completely, the stinger may fall.

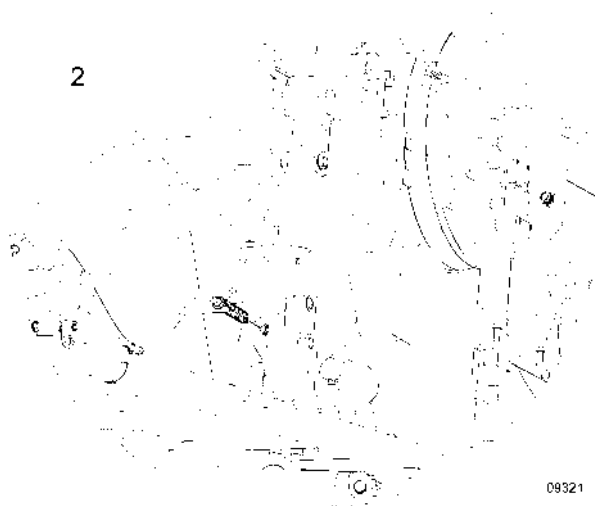

⇒ The safety flap (2) on the locking cylinder was turned using the rope arrangement.

5. Remove the crank handle again.

#### Slewing the fly jib to the boom head

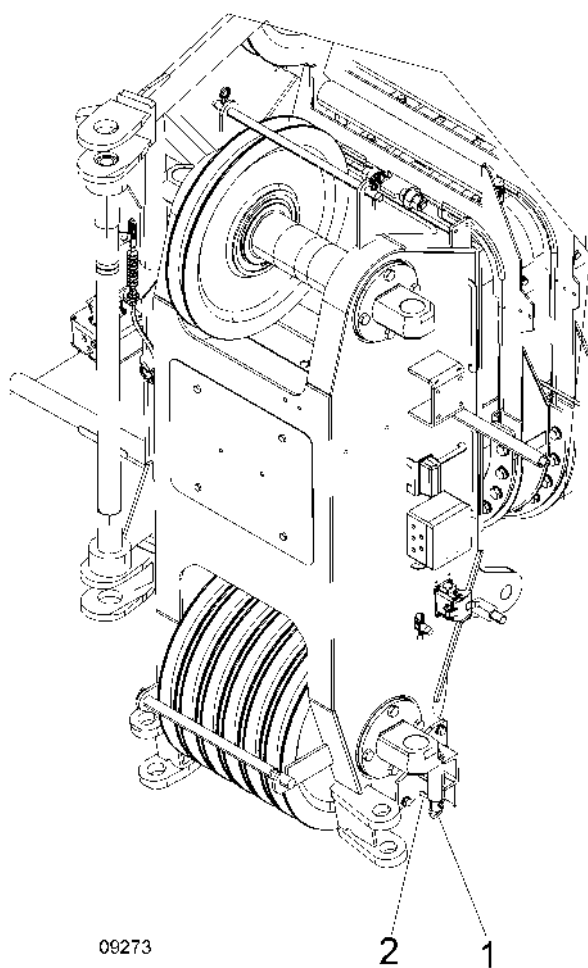

1. Release the lock on the left side of the boom head. For this, pull the ring (1) down and turn it by 90°. The pin (2) points towards the telescopic boom.
2. Loosen the hydraulic locking bolts between the telescopic boom and the stinger using the remote control (the left lever to the back).

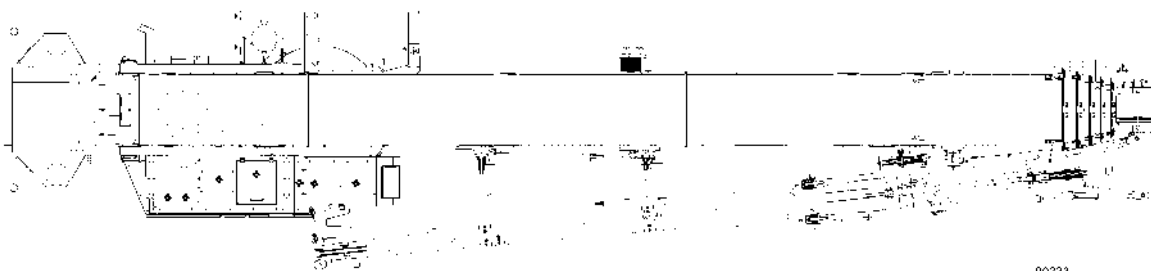

3. Extend the slewing cylinder completely using the remote control (the right lever to the front).  
⇒ The stinger rolls from the transporting supports.

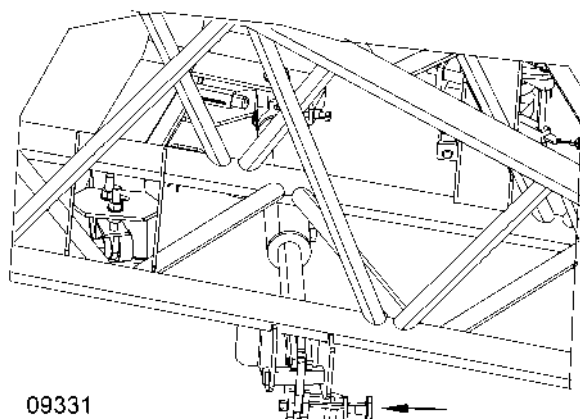

4. Pull the lock on the slewing cylinder.
  - ⇒ The stinger can be swiveled freely.
5. Loosen the guide belt of the mobile crane from below.
6. Swing open the stinger with the guide belt until it engages in the lock on the left side of the boom head.
  - ⇒ The holes on the 3.8-m-fly jib (12.5 ft) align with the holes on the left side of the boom head.

#### Erecting and securing the sheave

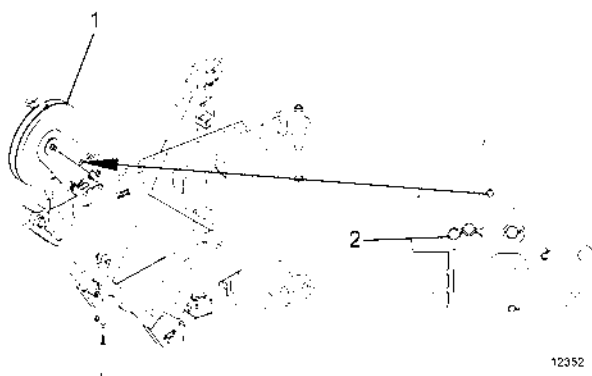

1. Wind the sheave of the 3.8-m-fly jib (12.5 ft) using the crank handle until further turning is not possible and the sheave is completely supported on the adapter. **⚠ CAUTION! If the sheave is not completely supported on the adapter, it may lead to uncontrolled lowering of the lifting load.**
2. Secure the supported sheave with a pin. Secure the pin using a spring clip.
3. Remove the crank handle again.

#### Bolting the fly jib on the boom head

1. Unwind the hoisting rope until the rope end projects above the complete fly jib and stow it to the side. **NOTICE! Do not drag the hoisting rope on the ground.**

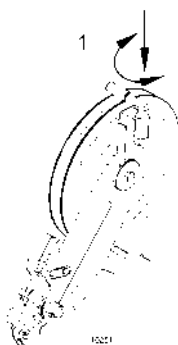

2. Place the hoisting rope on the sheave of the 3.8-m-stinger foot (12.5 ft). To do so, push the securing clamp (1) down and turn to the locked position (2). Place the hoisting rope on the sheave and turn back the securing clamp.

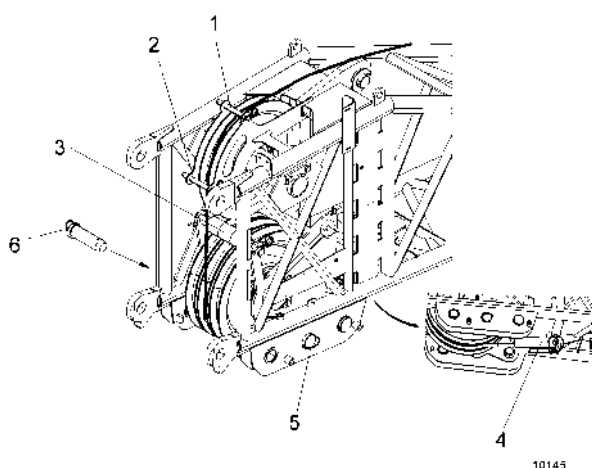

3. Owing to the dead weight of the stinger, the upper threaded bolt cannot be screwed in the upper hole of the bearing bracket as yet. To do this, lift the fly jib slightly using the hoisting gear, after the hoisting rope has been positioned and fixed to the rope fixing point of the fly jib.
4. Insert the crank handle into the threaded bolt and turn until the third red marking is completely visible.

**⚠ WARNING! The upper and lower bolt elements must be retracted completely (up to the end stop) in the bearing brackets on the boom head. Since both bolt ends are not retracted completely, the stinger may fall!**

5. Remove the crank handle again.
6. Establish electrical connection for the anti-twoblock device and the aircraft warning lamp\*) between the telescopic boom and the stinger.

#### Securing the transporting support

1. Retract the slewing cylinder using the remote control (the right lever to the back).

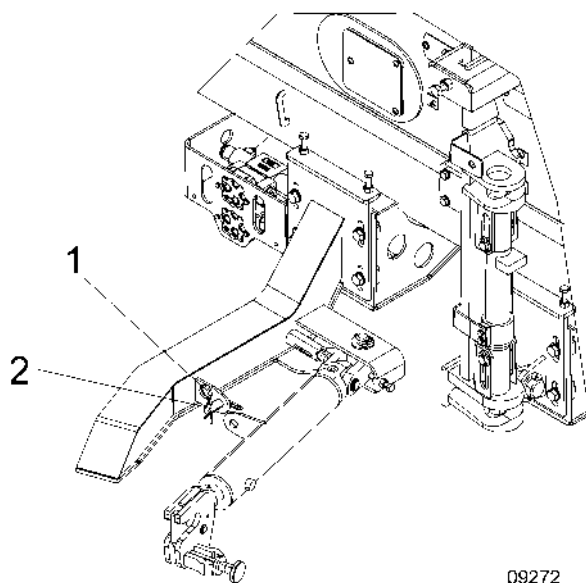

09272

2. Pin the slewing cylinder with the transporting support. Pull the spring clip (1) and bolt (2) for this. Push the slewing cylinder to the left until the hole on the transporting support aligns with the hole on the slewing cylinder. Loosen the bolt (2) and secure with the spring clip (1).
3. Switch off the engine and the ignition.
4. Detach the remote control.
5. Fold back the middle transporting support, pin and secure it.
6. Remove the guide belt from the fly jib.

### Bringing the boom tip into the working position

1. Fix the guide belt on the head of the boom end. Secure the other end of the belt to the 3.8-m-fly jib (12.5 ft) to prevent the boom tip from pivoting out uncontrollably.

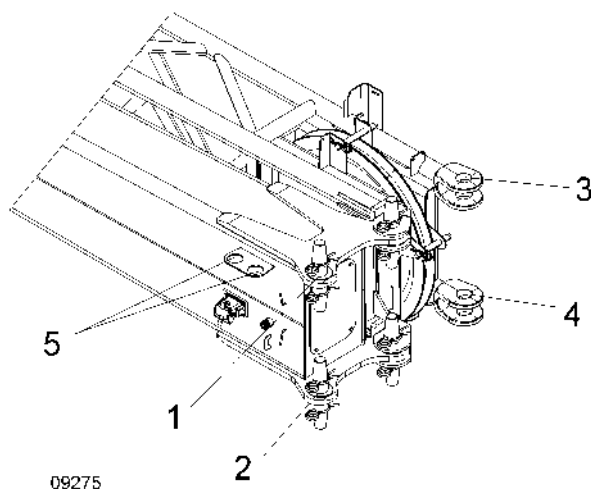

09275

2. Remove pins from holes (1) and (2). For this, pull the spring clip, pull out the pins, insert them into the pin compartment (5) and secure them.

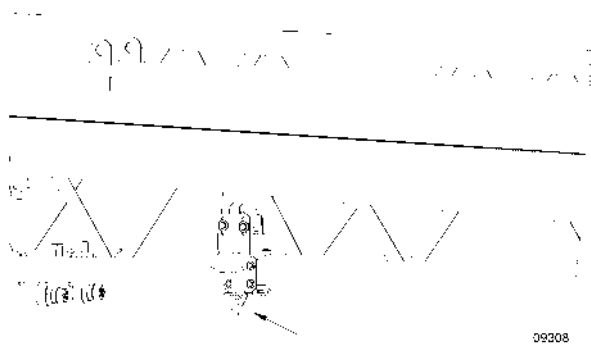

3. Loosen the pins between the 6.0-m-stinger foot (19.7 ft) and the boom end. For this, pull the retaining spring washer (using the crank handle) and turn it by 90°.
  - ⇒ The boom tip can be slewed freely.
4. Release the guide belt from the 3.8-m-fly jib foot (12.5 ft).

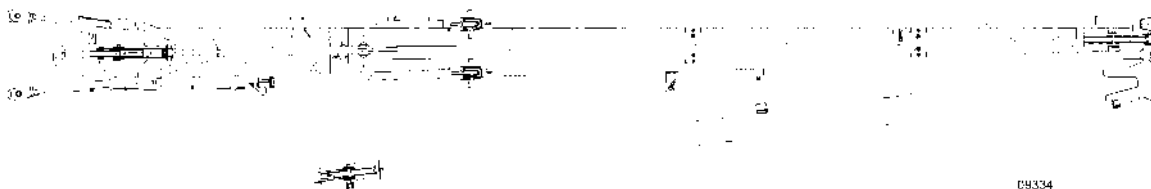

5. Pivot up the boom tip with the guide belt until the holes in the fly jib are flush with the holes on the fly jib foot.

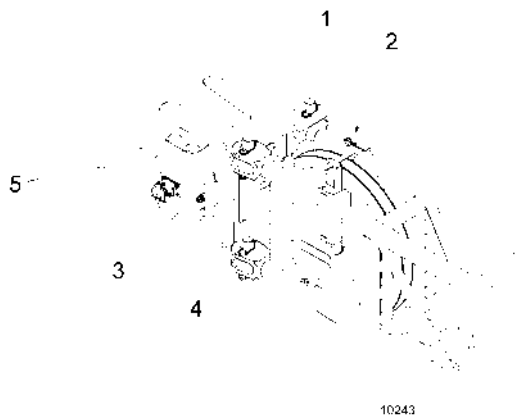

6. Take the pins out of the pin compartment (5), insert them into the holes (3) and (4) and secure them with spring clips.
7. Remove the guide belt from the boom tip.

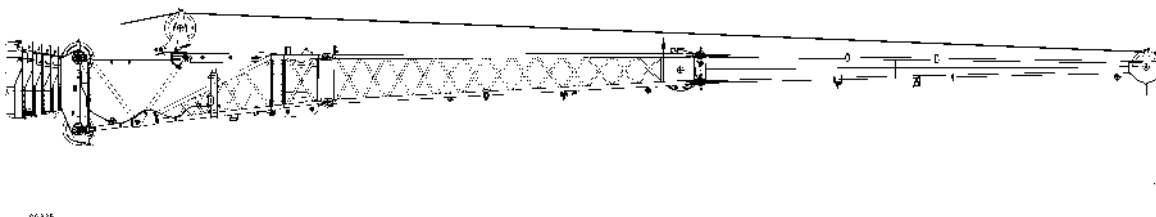



8. Place the hoisting rope on the sheave of the boom tip. To do this, pull the spring clip, remove the securing clamp and fit the hoisting rope. Secure the hoisting rope again with the securing clamp and spring clip.
9. Establish an electrical connection for the anti-twoblock device and the aircraft warning lamp\*) between the 6.0-m-fly jib foot (19.7 ft) and the boom tip.

### Finishing work

1. Mount the anti-twoblock device, *anemometer [page 160]* and *aircraft warning lamp [page 162]\**) on the head of the jib.
2. Guide the hoisting rope through the release weight of the anti-twoblock device.
3. Mount the *bottom block [page 403]*.
4. Enter the setup condition in the automatic safe load indicator.

### Working with the 10.2-m-stinger foot (33.5 ft)

The following section describes the structure of the 2-piece fly jib, i.e. the 3.8-m-fly jib (12.5 ft), and the 6.0-m-fly jib foot (19.7 ft).

### Requirements

- The mobile crane is supported as prescribed.
- Counterweights required for the crane operation are attached.
- The slewing gear brake is engaged.
- All telescopes are retracted.
- The superstructure is slewed to the back or side.
- The telescopic boom is set horizontally ( $\pm 1^\circ$ ).

**⚠ WARNING!** In case of larger angles, there is a risk of accident and personal injuries.

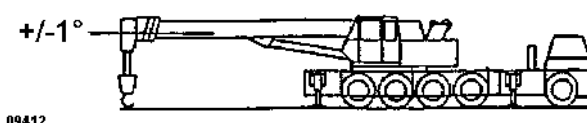

- The stinger (2-piece) is mounted at the transport position on the telescopic boom.
- The bottom block was placed on the ground and decoupled. The rope clamp and the release weight of the anti-twoblock device were removed from the hoisting rope. **NOTICE! This point is not necessary for crane work using hoisting gear 1 via the boom head or hoisting gear 2 via the jib.**
- The double ladder, crank handle and the remote control for the slewing cylinder are ready.

	<b>⚠ WARNING</b>
	<p><b>Risk of skidding and accident!</b></p> <p>When climbing and stepping on ladders and access ladders, take utmost care especially in case of humid weather.</p> <ol style="list-style-type: none"><li>1. Always keep the ladders and access ladders clean.</li><li>2. Remove dirt and other greasy substances immediately and thoroughly.</li><li>3. Always hold the ladder beams or handles while climbing up or down.</li><li>4. Wear non-slip shoes and keep them clean.</li><li>5. Ensure that the ladders are safe.</li></ol>

### Bringing the fly jib into the working position

#### Preparations

1. Switch on the battery main switch and the ignition in the crane cab. Start the superstructure engine.
2. Activate the  setup mode in the automatic safe load indicator.

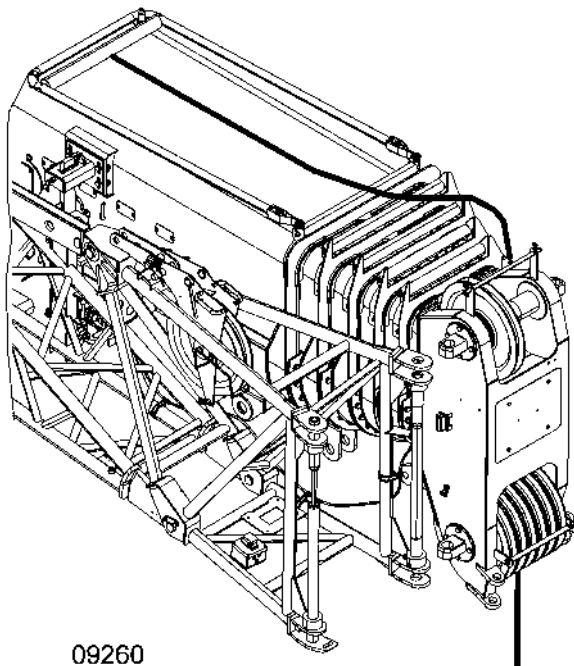

3. Wind/unwind the hoisting rope until the rope end projects above the boom head and stow it to the side. **NOTICE! Do not drag the hoisting rope on the ground.**

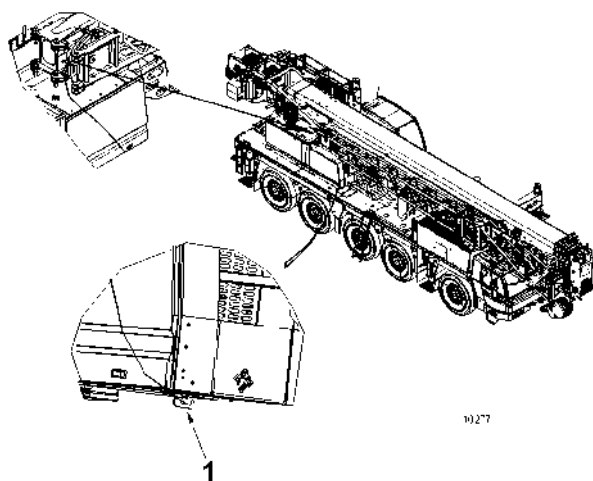

4. Fix the guide belt on the 6.0-m-stinger foot (19.7 ft). Secure the other end of the guide belt to the superstructure (1) to prevent the fly jib from pivoting out uncontrollably.

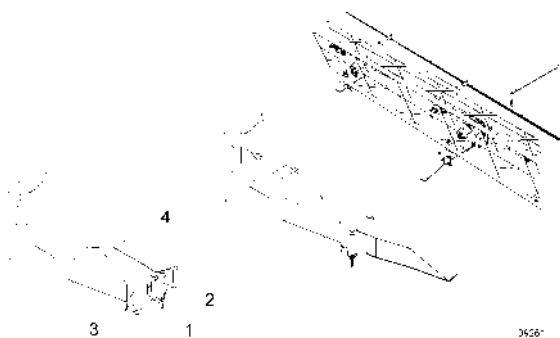

5. Fold out the transporting support. Remove the folding plug (1) and pull the bolt (2) downwards. Fold out the transporting support extension (4), insert the bolt (2) in the hole (3) from bottom and secure using the folding plug (1).
6. Connect the remote control.

#### Disconnecting the boom tip from the 6.0-m-stinger foot (19.7 ft)

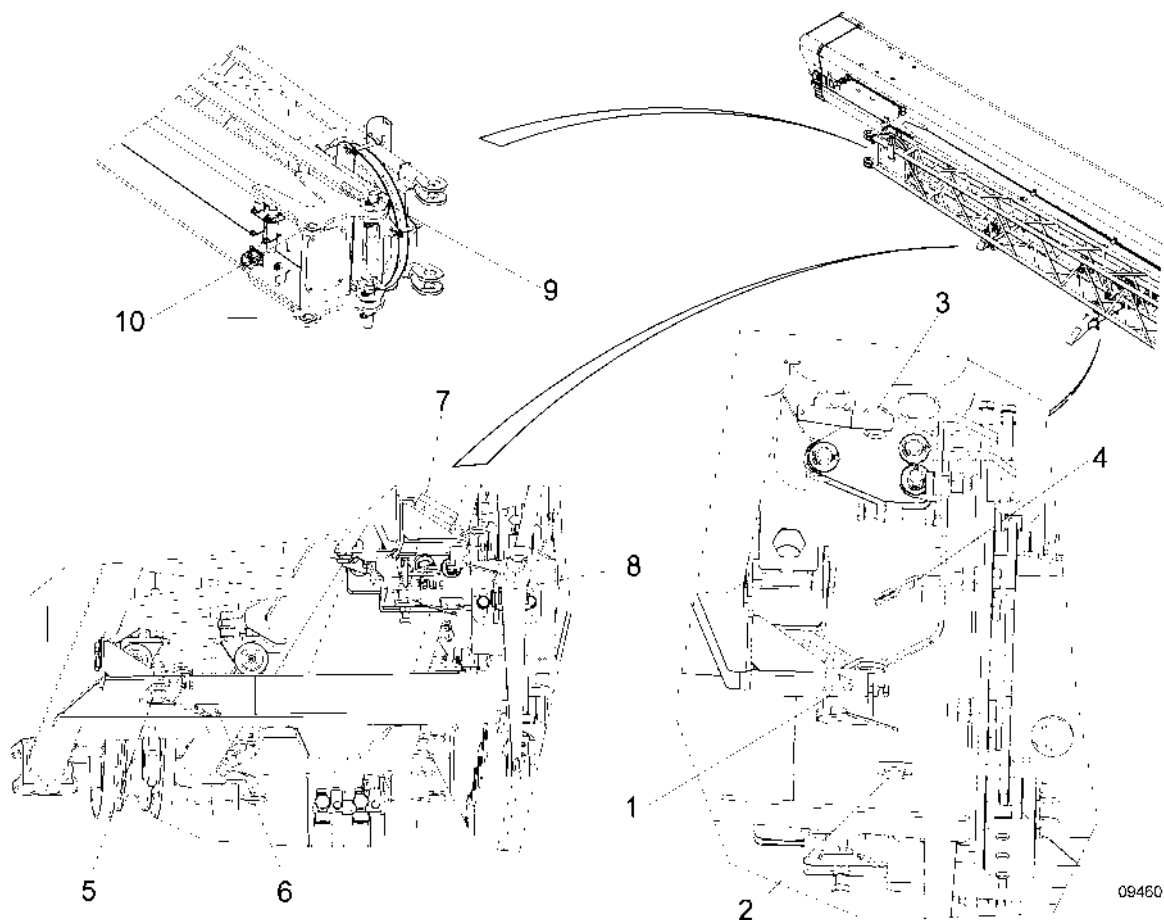

1. Release the pin (9) between the 6.0-m-fly jib foot (19.7 ft) and the boom tip.  
Pull the spring clip and the locking pin, insert into the hole (10) and secure again using the spring clip.
2. Loosen the pin (1) on the **middle** transporting support.  
Pull the spring clip and the locking pin, insert in the pin holder (2) and secure again using the spring clip.
3. Loosen the pin (5) on the **rear** transporting support.  
Pull the spring clip and the locking pin, insert in the pin holder (6) and secure again using the spring clip.

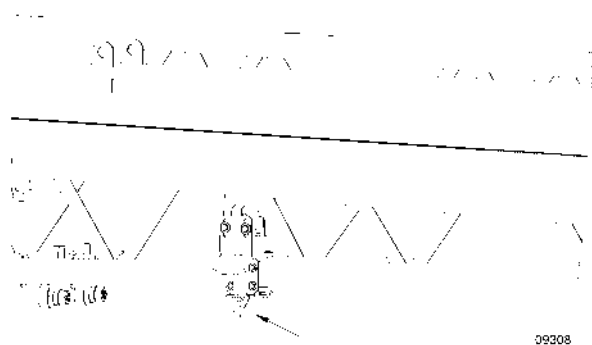

4. Loosen the pins between the 6.0-m-stinger foot (19.7 ft) and the boom tip. For this, pull the retaining spring washer (using the crank handle) and turn it by 90°.

#### Pivoting the fly jib to the boom head

1. Extend the slewing cylinder using the remote control (right lever forwards) until the holes on the 3.8-m-fly jib (12.5 ft) are flush with the holes on the right-hand side of the boom head.

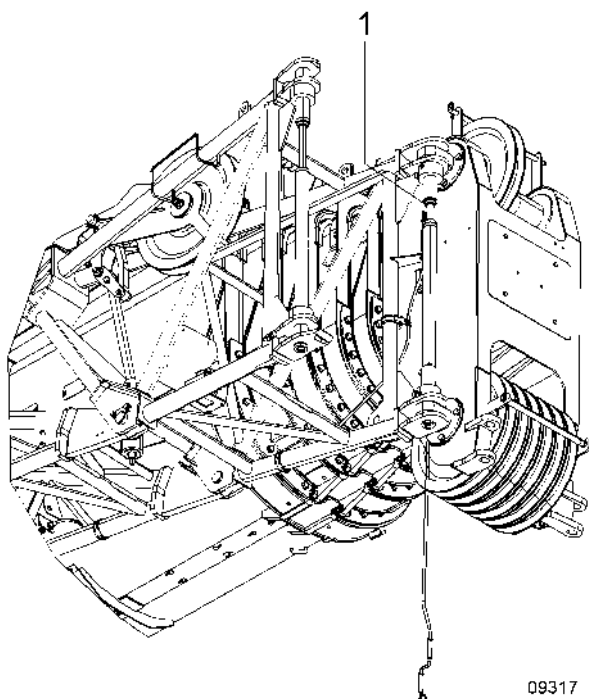

2. Insert the crank handle into the threaded bolt and turn until the third red marking (1) is completely visible. **⚠️WARNING!** The upper and lower bolt elements must be retracted completely (up to the end stop) in the bearing brackets on the boom head. Since both bolt ends are not retracted completely, the stinger may fall.

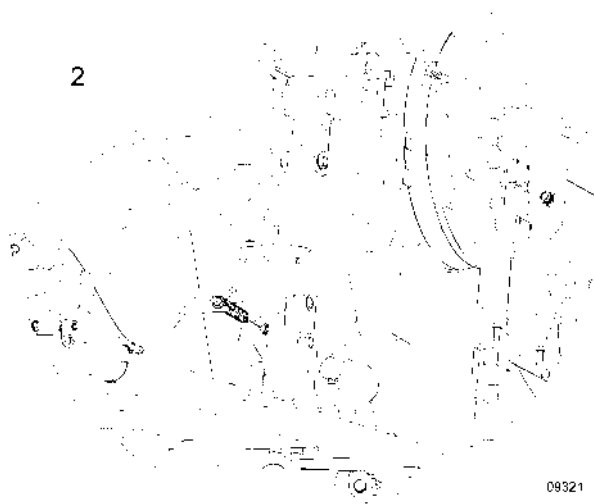

⇒ The safety flap (2) on the locking cylinder was turned using the rope arrangement.

3. Remove the crank handle again.

#### Slewing the fly jib to the boom head

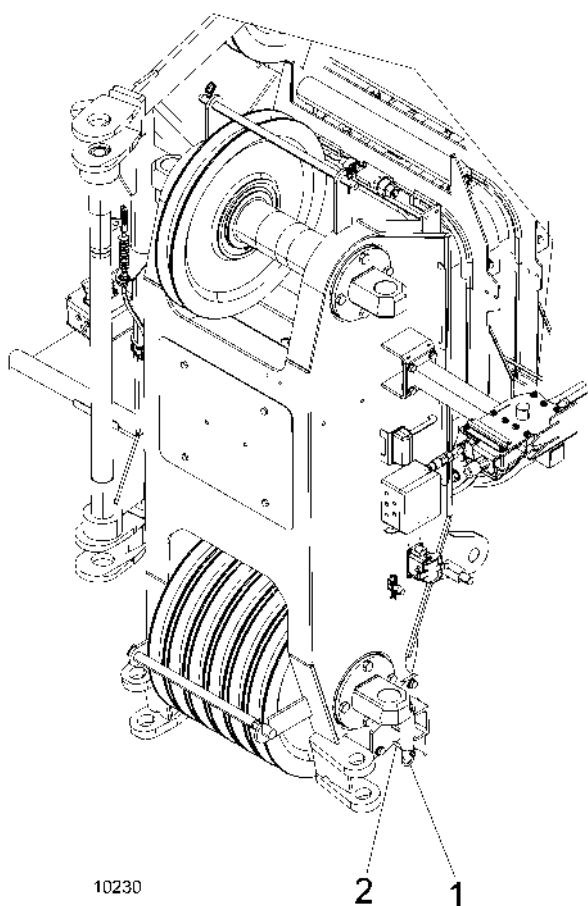

1. Release the lock on the left side of the boom head. For this, pull the ring (1) down and turn it by 90°. The pin (2) points towards the telescopic boom.
2. Loosen the hydraulic locking bolts between the telescopic boom and the stinger using the remote control (the left lever to the back).



3. Extend the slewing cylinder completely using the remote control (the right lever to the front).
  - ⇒ The stinger rolls from the transporting supports.

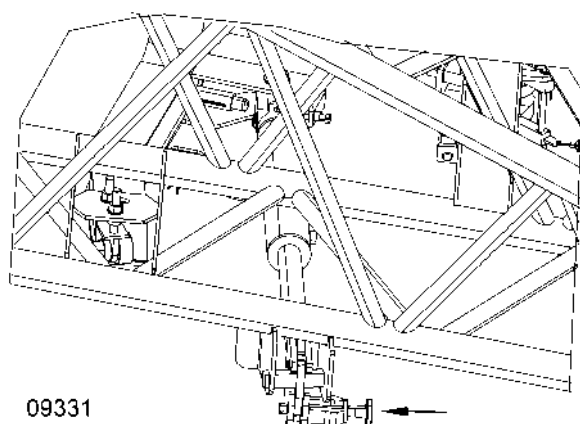

4. Pull the lock on the slewing cylinder.
  - ⇒ The stinger can be swiveled freely.
5. Loosen the guide belt of the mobile crane from below.
6. Swing open the stinger with the guide belt until it engages in the lock on the left side of the boom head.
  - ⇒ The holes on the 3.8-m-fly jib (12.5 ft) align with the holes on the left side of the boom head.

### Erecting and securing the sheave

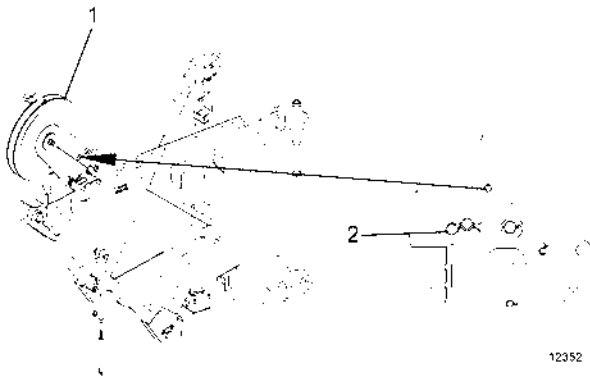

1. Wind the sheave of the 3.8-m-fly jib (12.5 ft) using the crank handle until further turning is not possible and the sheave is completely supported on the adapter. **⚠ CAUTION! If the sheave is not completely supported on the adapter, it may lead to uncontrolled lowering of the lifting load.**
2. Secure the supported sheave with a pin. Secure the pin using a spring clip.
3. Remove the crank handle again.

### Bolting the fly jib on the boom head

1. Unwind the hoisting rope until the rope end projects above the complete fly jib and stow it to the side. **NOTICE! Do not drag the hoisting rope on the ground.**



2. Place the hoisting rope on the sheave of the 3.8-m-stinger foot (12.5 ft). To do so, push the securing clamp (1) down and turn to the locked position (2). Place the hoisting rope on the sheave and turn back the securing clamp.



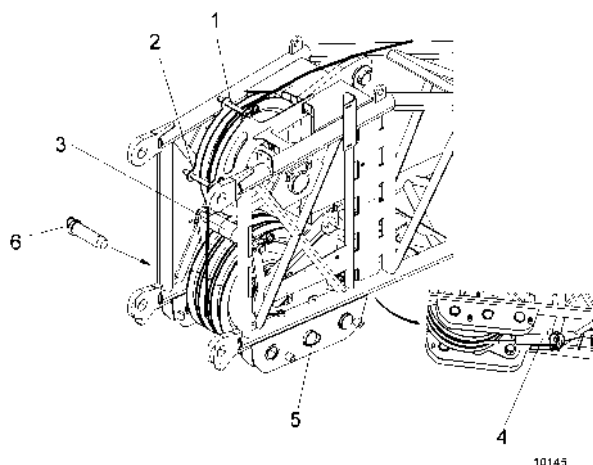

3. Owing to the dead weight of the stinger, the upper threaded bolt cannot be screwed in the upper hole of the bearing bracket as yet. To do this, lift the fly jib slightly using the hoisting gear, after the hoisting rope has been positioned and fixed to the rope fixing point of the fly jib.
4. Insert the crank handle into the threaded bolt and turn until the third red marking is completely visible.

**⚠ WARNING!** The upper and lower bolt elements must be retracted completely (up to the end stop) in the bearing brackets on the boom head. Since both bolt ends are not retracted completely, the stinger may fall!

5. Remove the crank handle again.
6. Establish electrical connection for the anti-two-block device and the aircraft warning lamp\*) between the telescopic boom and the stinger.

#### Securing the transporting support

1. Retract the slewing cylinder using the remote control (the right lever to the back).

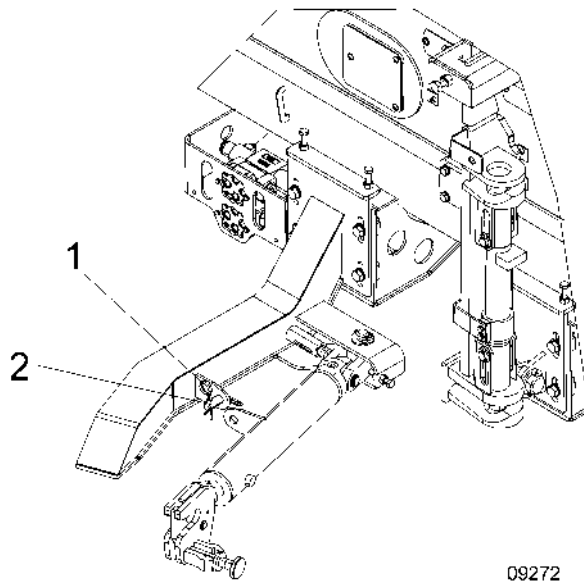

2. Pin the slewing cylinder with the transporting support. Pull the spring clip (1) and bolt (2) for this. Push the slewing cylinder to the left until the hole on the transporting support aligns with the hole on the slewing cylinder. Loosen the bolt (2) and secure with the spring clip (1).
3. Switch off the engine and the ignition.
4. Detach the remote control.
5. Fold back the transporting support, pin and secure it.
6. Remove the guide belt from the 6.0-m-stinger foot (19.7 ft).
7. Place the hoisting rope on the head of the 6.0-m-stinger foot (19.7 ft) and secure it using securing clamps.

### Finishing work

1. Mount the anti-twoblock device, *anemometer* [page 160] and *aircraft warning lamp* [page 162<sup>\*</sup>) on the head of the jib.
2. Guide the hoisting rope through the release weight of the anti-twoblock device.
3. Mount the *bottom block* [page 403].
4. Enter the setup condition in the automatic safe load indicator.

### Working with the 3.8-m-stinger foot (12.5 ft)

The following section describes the structure of the 3.8-m-fly jib (12.5 ft).

### Requirements

- The mobile crane is supported as prescribed.
- Counterweights required for the crane operation are attached.
- The slewing gear brake is engaged.

- All telescopes are retracted.
- The superstructure is slewed to the back or side.
- The telescopic boom is set horizontally ( $\pm 1^\circ$ ).

**⚠ WARNING! In case of larger angles, there is a risk of accident and personal injuries.**



09412

- The stinger (3-piece) is mounted at the transport position on the telescopic boom.
- The heavy-lift sheave is mounted on the 3.8-m-fly jib foot (12.5 ft).
- The bottom block was placed on the ground and decoupled. The rope clamp and the release weight of the anti-twoblock device were removed from the hoisting rope.
- The double ladder, crank handle and the remote control for the slewing cylinder are ready.

### **⚠ WARNING**



#### **Risk of skidding and accident!**

When climbing and stepping on ladders and access ladders, take utmost care especially in case of humid weather.

1. Always keep the ladders and access ladders clean.
2. Remove dirt and other greasy substances immediately and thoroughly.
3. Always hold the ladder beams or handles while climbing up or down.
4. Wear non-slip shoes and keep them clean.
5. Ensure that the ladders are safe.

### Separating the 3.8-m-stinger foot (12.5 ft) from the 6.0-m-stinger foot (19.7 ft)

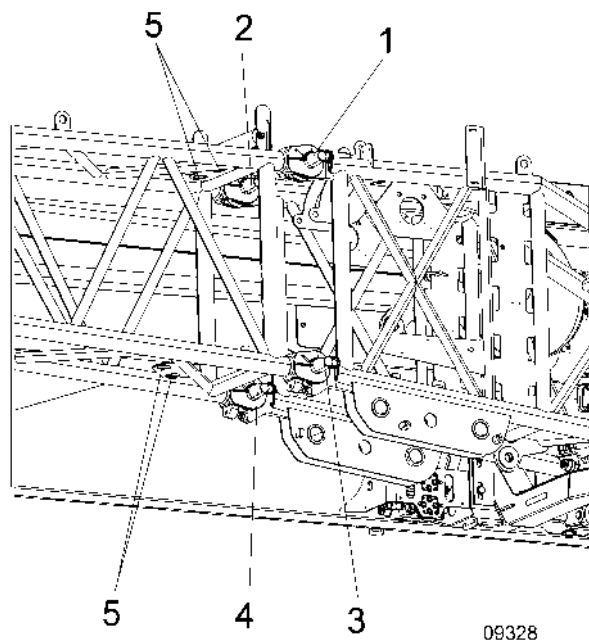

1. Remove the pins from holes (1), (2), (3) and (4), insert them into pin compartments (5) and secure them.

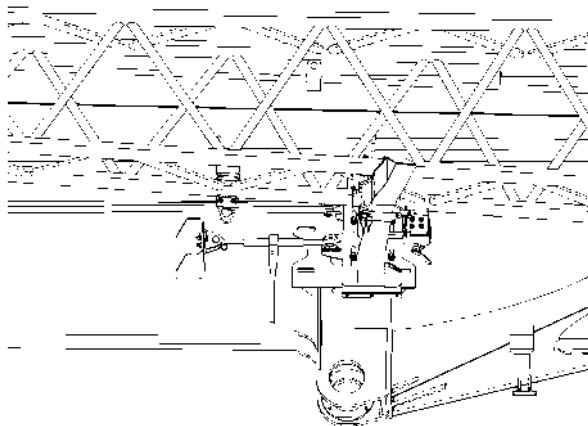

2. Move the 6.0-m-stinger foot (19.7 ft) up to the left end stop using the ratchet chain clamp. The 3.8-m-stinger (12.5 ft) is connected with the 6.0-m-stinger foot (19.7 ft) in the logical reverse order.

### Bringing the fly jib into the working position

#### Preparations

1. Switch on the battery main switch and the ignition in the crane cab. Start the superstructure engine.

2. Activate the  setup mode in the automatic safe load indicator.

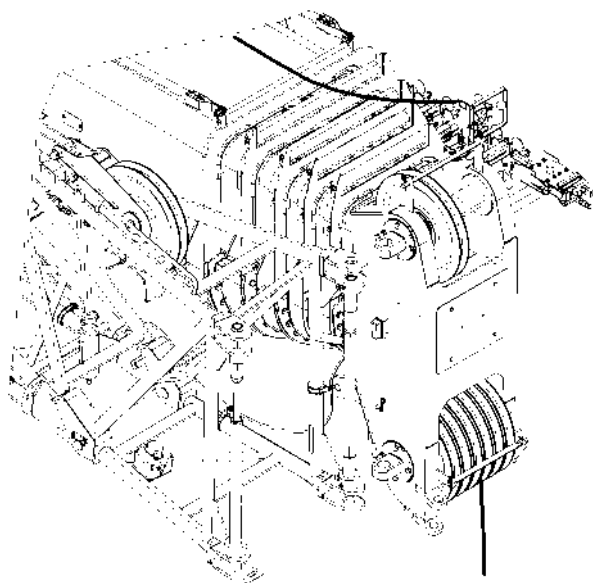

10195

3. Wind/unwind the hoisting rope until the rope end projects above the boom head and stow it to the side. **NOTICE! Do not drag the hoisting rope on the ground.**
4. Fix the guide belt on the 3.8-m-stinger (12.5 ft). Secure the other end of the guide belt to the mobile crane at a suitable point to prevent the fly jib from pivoting out uncontrollably.
5. Connect the remote control.

#### Pivoting the fly jib to the boom head

1. Extend the slewing cylinder using the remote control (right lever forwards) until the holes on the 3.8-m-fly jib (12.5 ft) are flush with the holes on the right-hand side of the boom head.

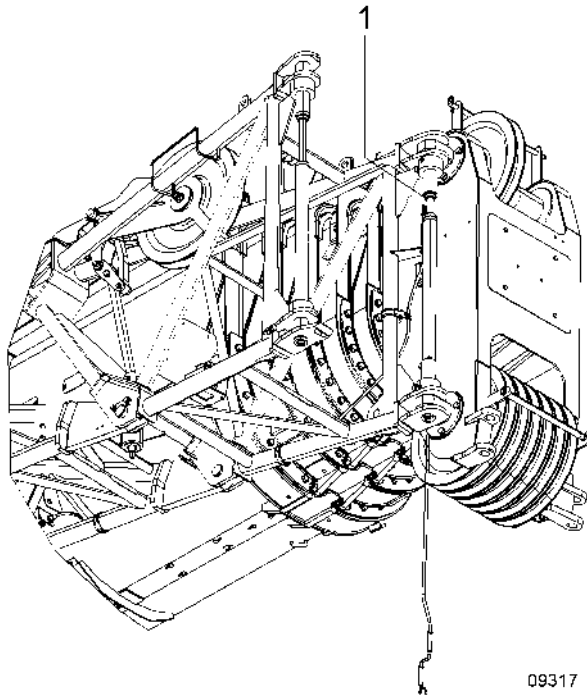

2. Insert the crank handle into the threaded bolt and turn until the third red marking (1) is completely visible. **⚠️ WARNING!** The upper and lower bolt elements must be retracted completely (up to the end stop) in the bearing brackets on the boom head. Since both bolt ends are not retracted completely, the stinger may fall.

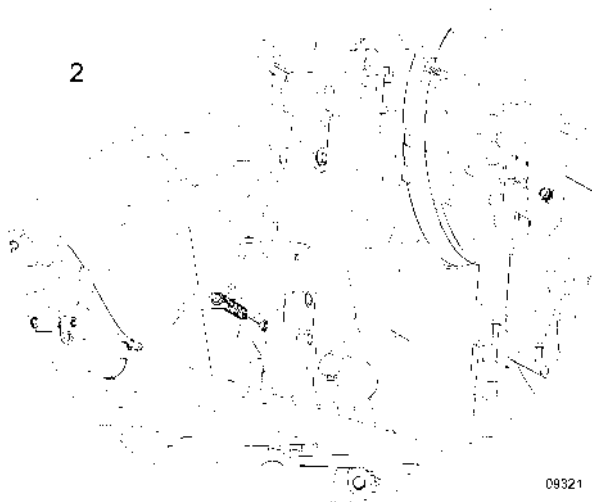

⇒ The safety flap (2) on the locking cylinder was turned using the rope arrangement.

3. Remove the crank handle again.

## Slewing the fly jib to the boom head

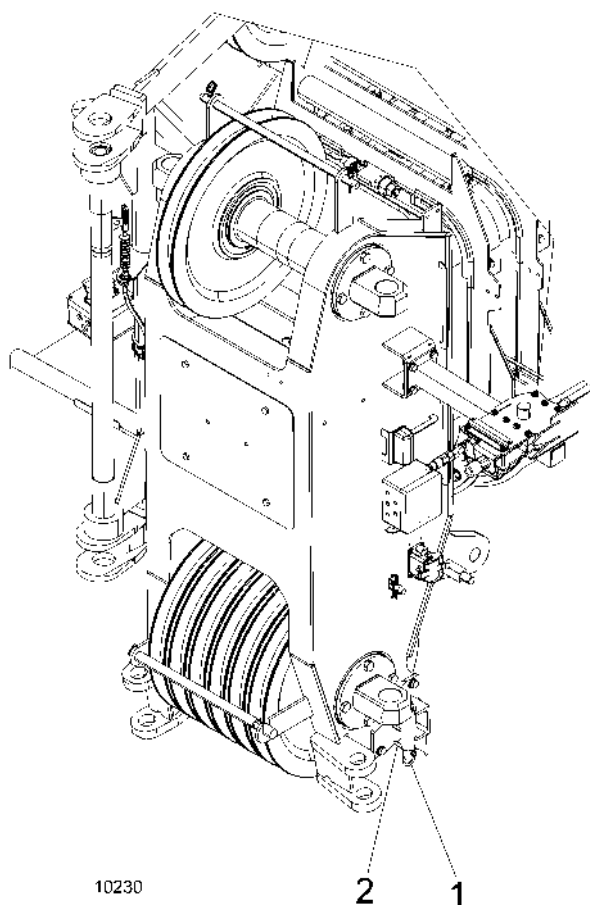

1. Release the lock on the left side of the boom head. For this, pull the ring (1) down and turn it by 90°. The pin (2) points towards the telescopic boom.
2. Loosen the hydraulic locking bolts between the telescopic boom and the stinger using the remote control (the left lever to the back).

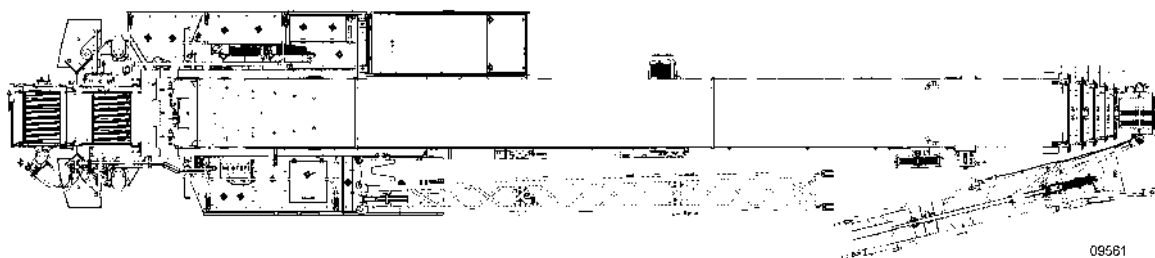

3. Extend the slewing cylinder completely using the remote control (the right lever to the front).  
⇒ The stinger foot rolls from the transporting support.

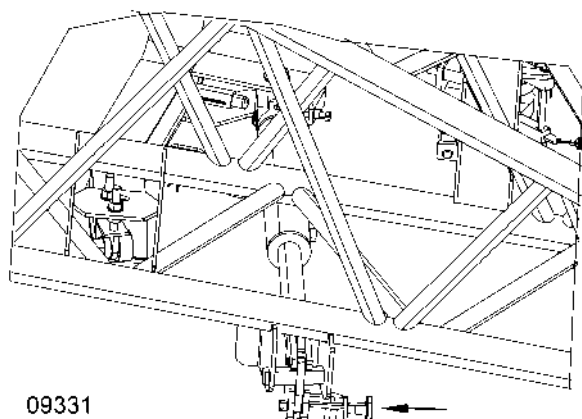

4. Pull the lock on the slewing cylinder.  
⇒ The stinger can be swiveled freely.
5. Loosen the guide belt of the mobile crane from below.
6. Swing open the stinger with the guide belt until it engages in the lock on the left side of the boom head.  
⇒ The holes on the 3.8-m-fly jib (12.5 ft) align with the holes on the left side of the boom head.

#### Erecting and securing the sheave

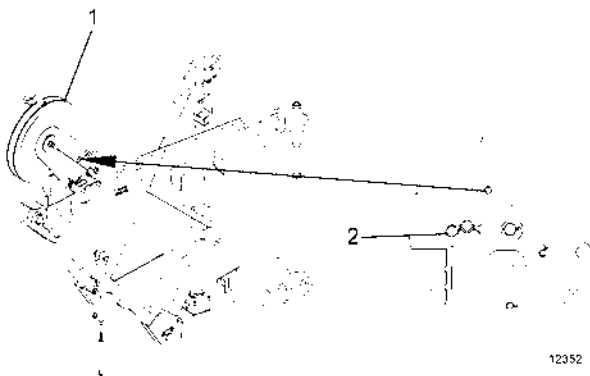

1. Wind the sheave of the 3.8-m-fly jib (12.5 ft) using the crank handle until further turning is not possible and the sheave is completely supported on the adapter. **⚠ CAUTION! If the sheave is not completely supported on the adapter, it may lead to uncontrolled lowering of the lifting load.**
2. Secure the supported sheave with a pin. Secure the pin using a spring clip.
3. Remove the crank handle again.

#### Bolting the fly jib on the boom head

1. Unwind the hoisting rope until the rope end projects above the complete fly jib and stow it to the side. **NOTICE! Do not drag the hoisting rope on the ground.**



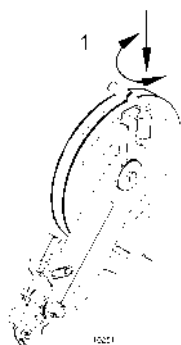

- Place the hoisting rope on the sheave of the 3.8-m-stinger foot (12.5 ft). To do so, push the securing clamp (1) down and turn to the locked position (2). Place the hoisting rope on the sheave and turn back the securing clamp.

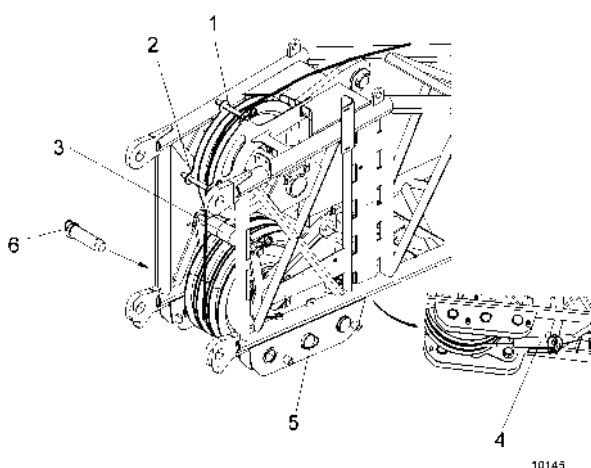

- Owing to the dead weight of the stinger, the upper threaded bolt cannot be screwed in the upper hole of the bearing bracket as yet. To do this, lift the fly jib slightly using the hoisting gear, after the hoisting rope has been positioned and fixed to the rope fixing point of the fly jib.
- Insert the crank handle into the threaded bolt and turn until the third red marking is completely visible.
 

**⚠️ WARNING! The upper and lower bolt elements must be retracted completely (up to the end stop) in the bearing brackets on the boom head. Since both bolt ends are not retracted completely, the stinger may fall!**
- Remove the crank handle again.
- Establish electrical connection for the anti-twoblock device and the aircraft warning lamp\*) between the telescopic boom and the stinger.

### Securing the transporting support

- Retract the slewing cylinder using the remote control (the right lever to the back).

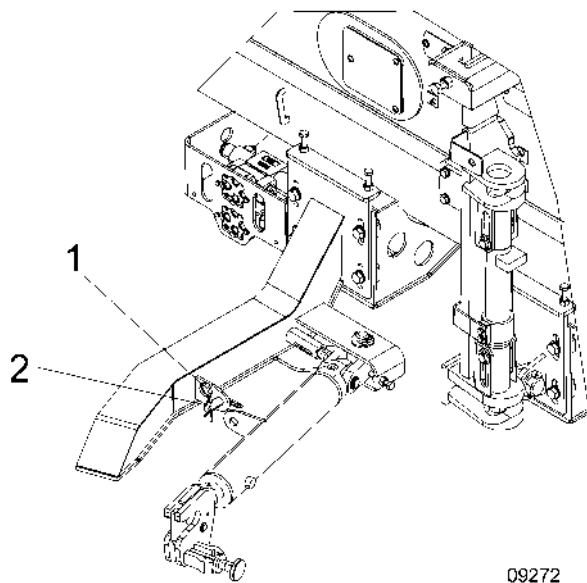

2. Pin the slewing cylinder with the transporting support. Pull the spring clip (1) and bolt (2) for this. Push the slewing cylinder to the left until the hole on the transporting support aligns with the hole on the slewing cylinder. Loosen the bolt (2) and secure with the spring clip (1).
3. Switch off the engine and the ignition.
4. Detach the remote control.
5. Remove the guide belt from the 3.8-m-fly jib (12.5 ft).

#### Folding down the roller carrier - working position

	<p>In the working position, the sheave carrier must be folded down and secured.</p> <p>In the transport position, the sheave carrier must be folded up and secured.</p>
---	---

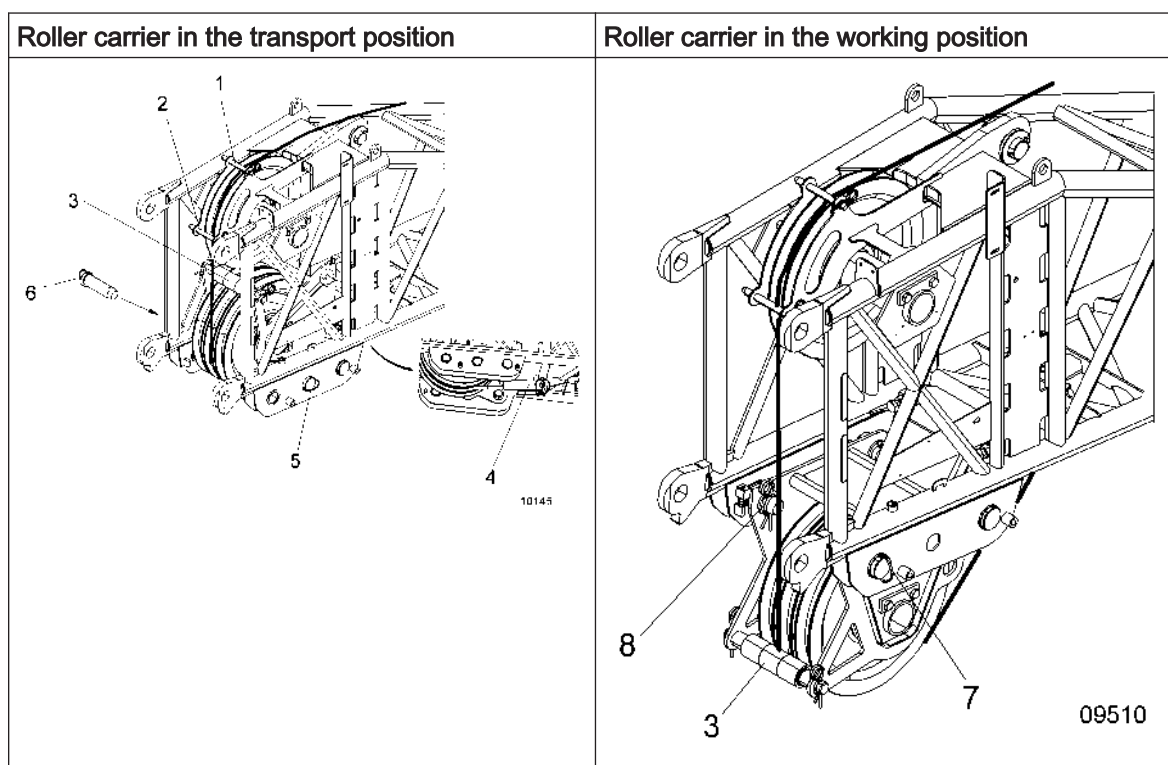

1. Place the hoisting rope on the upper sheave on the head of the 3.8 m (12.5 ft) stinger foot. For this, pull the spring clip and the securing clamps (1), (2). Place the hoisting rope on the sheave and secure again using the securing clamps (1), (2) and the spring clip.
  2. Place the hoisting rope on the sheaves of the roller carrier. Remove the rope holding sheaves (3). For this, pull the spring clip and remove the securing clamp and rollers.
  3. Fix the hoisting rope with the rope clamp at the fixing point of the 3.8 m (12.5 ft) stinger foot (4).
  4. Tension the hoisting rope by carefully winding it in. The pressure on pins (5) and (6) is relieved.
  5. Remove the spring clip and pins from holes (5) and (6).
  6. Unwind the hoisting rope carefully until the sheave carrier folds down up to the end stop.
  7. Pin the sheave carrier. For this, insert the pins into holes (7) and (8) and secure them using the spring clip.
    - ⇒ The sheave carrier is in the working position.
  8. Loosen the hoisting rope from the fixing point.
  9. Reeve the hoisting rope on the sheave carrier and the bottom block.
  10. Secure the hoisting rope using rope holding sheaves (3). For this, attach the securing clamp and rollers again and secure them using the spring clip.
- Fold up the sheave carrier in the transport position in the logical reverse order. **NOTICE! Remove the rope holding sheaves (3) before folding up.**

### Finishing work

1. Mount the anti-twoblock device, *anemometer* [page 160] and *aircraft warning lamp* [page 162\*) on the head of the jib.
2. Guide the hoisting rope through the release weight of the anti-twoblock device.
3. Enter the setup condition in the automatic safe load indicator.

### Bending the fly jib

No intermediate sections may be mounted guy rope when bending with the hoisting rope as a guy rope. This variant is described below.

When bending with the mounted intermediate sections, the boom end must be dismantled properly.

The stinger may not be lifted using the hoisting rope any longer.

Do not move the mobile crane when bending the jib.

#### Prerequisite:

- The mobile crane is supported as prescribed.
- The slewing gear brake is engaged.
- All telescopes are retracted.
- The superstructure is slewed to the back.
- The telescopic boom is lowered.
- The stinger is mounted at the working position on the telescopic boom.
- The bottom block was placed on the ground and decoupled. The release weight of the anti-two-block device was removed from the hoisting rope.
- The setup mode in the automatic safe load indicator is activated.



#### NOTICE

##### Material damage!

Raising and winding the hoisting rope simultaneously is not allowed when bending.

1. When bending the stinger, always raise the telescopic boom such that the head of the stinger does not touch the ground.
2. Check whether all pins and plugs are secured and the cable plug of the antitwoblock device has been connected correctly.

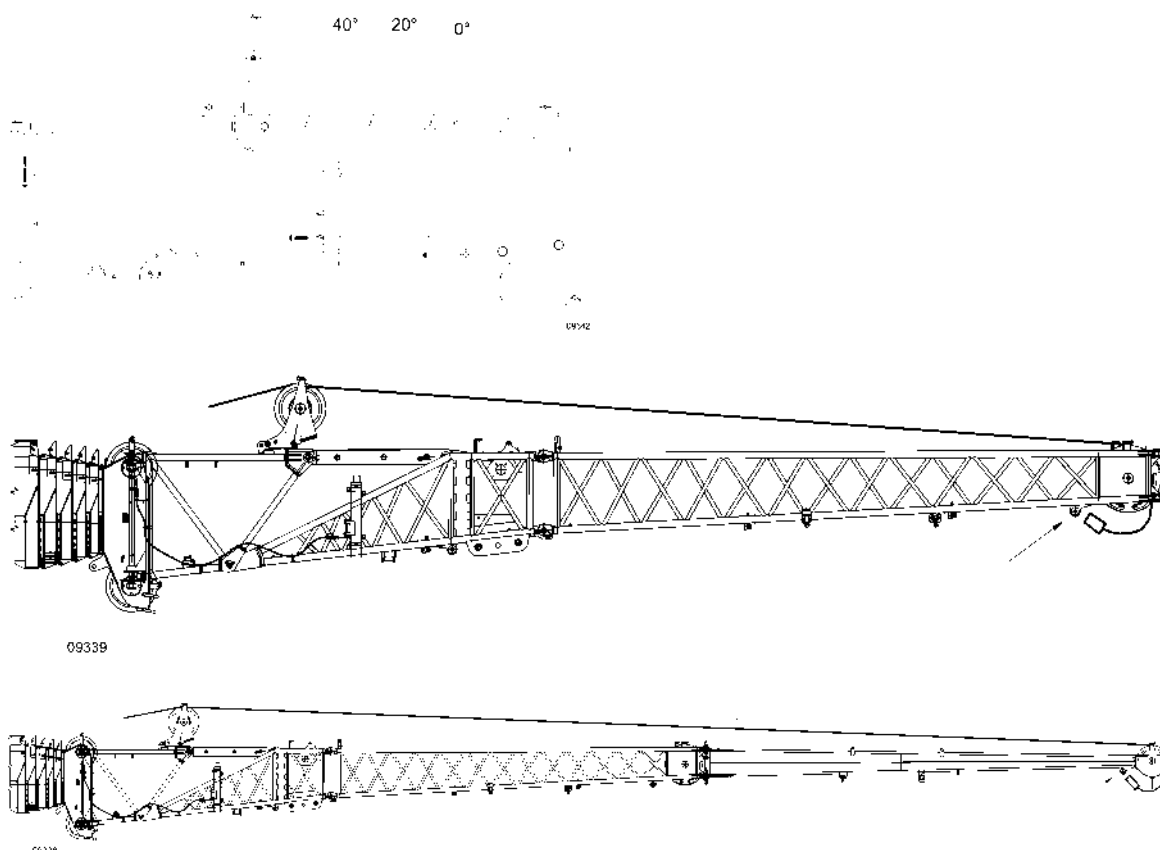

1. Place the hoisting rope and attach it to the fixing point of the 6.0-m-fly jib foot (19.7 ft) or the boom tip along with a rope clamp, pin it and secure it.
2. Wind the hoisting rope carefully and slowly to reduce the tension. Continue until the bending pin is released. (The jib is slightly lifted while doing so.)
3. Remove the spring clip from the current angle position and pull out the bending pin.
4. Insert the bending pin into the hole for the desired angle position (0°, 20° or 40°) and secure it using the spring clip.
5. When bending, raise the telescopic boom up to an adequate distance from the ground so that the rope clamp can be removed.
6. Wind or unwind the hoisting rope carefully and slowly until the jib reaches the desired angle position. **NOTICE! The boom end may not touch the ground.**
7. Release the hoisting rope (by unwinding slightly).
8. Loosen the rope clamp from the fixing point.
9. Mount the bottom block, anti-twoblock device and the release weight.
10. Enter the setup condition in the automatic safe load indicator.

#### Installing of the intermediate sections

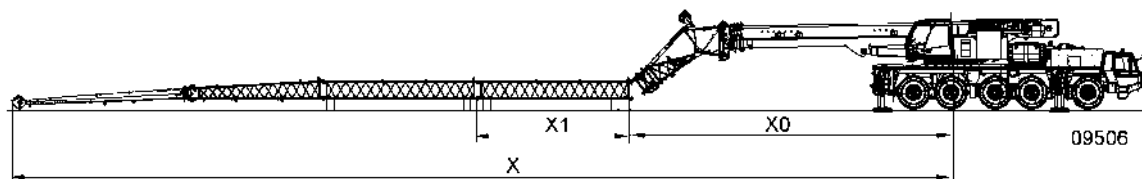

X	Distance from the rotation centre up to the jib head = 42.0 m (137.8 ft)
X0	Distance from the rotation centre up to the 1st intermediate section = 14.5 m (47.6 ft)
X1	Length of an intermediate section = 7.0 m (23.0 ft)

Intermediate sections are mounted between the 3.8-m-stinger (12.5 ft) and the 6.0-m-stinger foot (19.7 ft). **NOTICE! A maximum of two intermediate sections can be mounted.**

Prerequisite:

- There should be no obstacles in the movement range.
  - The mobile crane is supported as prescribed.
  - The slewing gear brake is engaged.
  - All telescopes are retracted.
  - The superstructure is slewed to the back.
  - The telescopic boom is lowered.
  - The stinger (3-piece) is mounted at the working position on the telescopic boom.
  - The setup mode in the automatic safe load indicator is activated.
  - The bottom block was placed on the ground and decoupled. The release weight of the anti-two-block device was removed from the hoisting rope.
  - Wind up the hoisting rope under tension until the rope end can be placed in front of the sheave on the 3.8-m-fly jib (12.5 ft). **NOTICE! Do not drag the hoisting rope on the ground.**
1. Lower the mobile crane using the rear outriggers.
  2. Pin and secure the hoisting rope with the rope clamp at the fixing point of the 3.8-m-stinger (12.5 ft).

#### Separating the 6.0-m-stinger foot (19.7 ft) with the boom end from the 3.8-m-stinger (12.5 ft)

The 6.0-m-stinger foot (19.7 ft) remains pinned with the boom end.

1. Disconnect the electrical connection for the anti-two-block device and the aircraft warning lamp\*) between the 3.8-m-stinger (12.5 ft) and the 6.0-m-stinger foot (19.7 ft).
2. Wind the hoisting rope carefully and slowly to reduce the tension. Continue until the bending pin is released. (The jib is slightly lifted while doing so.).
3. Remove the bending pin from the 0° angle position. For this, remove the spring clip and pull out the bending pin.
4. Insert the bending pin into the hole for the 40° angle position and secure it with the spring clip.

- Lower the telescopic boom completely and unwind the hoisting rope until the boom end slightly above the ground.

**⚠️ DANGER!** Luff down the boom with jib carefully. If the jib hits the ground, the jib and/or mobile crane may be damaged.

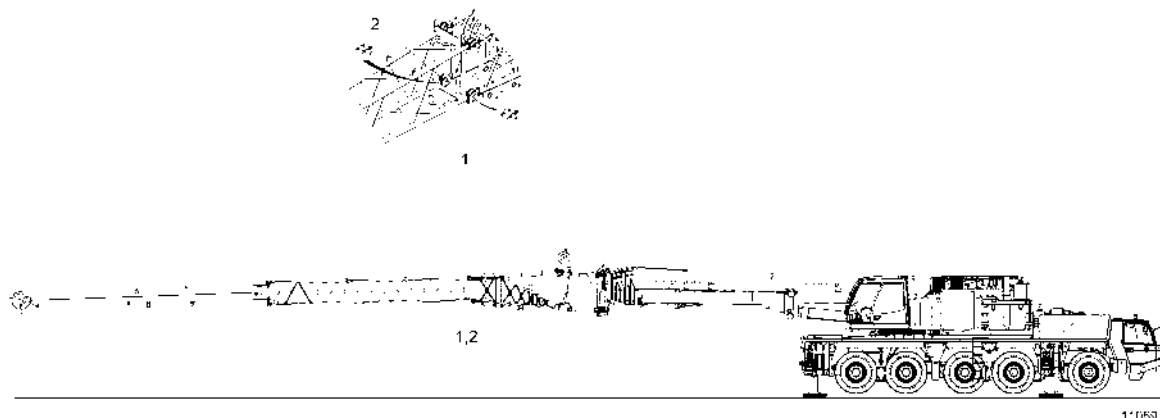

- Remove both the lower pins (1) and (2). For this, pull the spring clip and pins, insert them into the pin compartment and secure them.
- Unwind the hoisting rope carefully and slowly until the boom end and the 6.0-m-stinger (19.7 foot) foot lie on the ground. Support the tip properly.

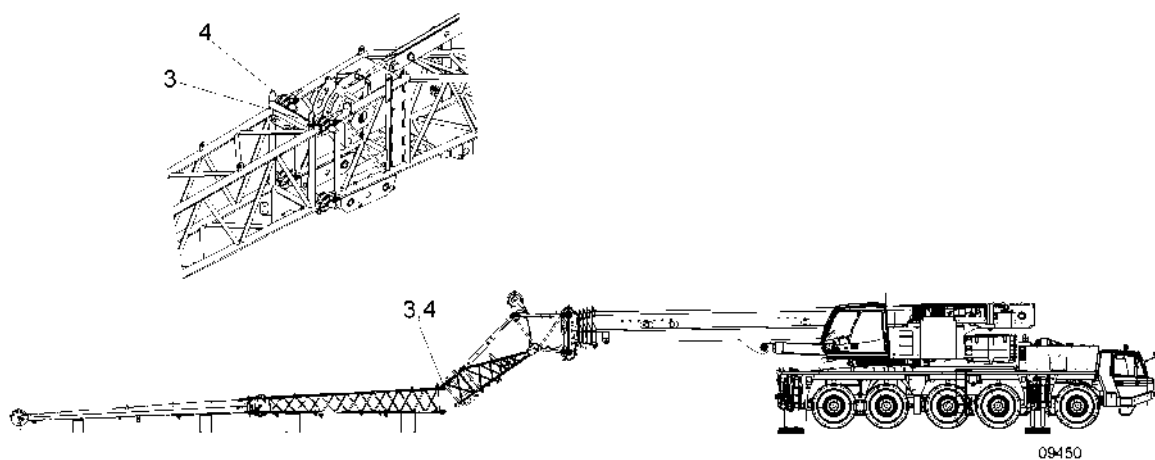

- Remove both the upper pins (3) and (4). For this, pull the spring clip and pins, insert them into the pin compartment and secure them.

### Attaching the intermediate sections

Position the intermediate section(s) and the 6.0-m-stinger foot (19.7 ft) with the boom end in front of the 3.8-m-stinger (12.5 ft) such that they can be attached one after the other.



09502



09503

#### Attaching the first intermediate section

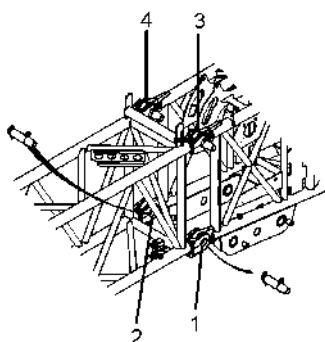

09501

- The 3.8-m-stinger (12.5 ft) is bent to 40°.
  - The hoisting rope is pinned and secured with the rope clamp at the fixing point of the 3.8-m-stinger (12.5 ft).
1. Lower the telescopic boom until the upper holes of the 3.8-m-fly jib (12.5 ft) (3) and (4) align with the upper holes of the first intermediate section.
  2. Remove the pins from the pin holder of the intermediate section, insert them into holes (3) and (4) sideways and secure them using the spring clip.
  3. Remove the bending pin from the 40° angle position, insert it into the 20° angle position and secure it with the spring clip.
  4. Raise the telescopic boom carefully until the intermediate section no longer touches the ground and the lower holes of the 3.8-m-stinger (12.5 ft) (1) and (2) align with the lower holes of the intermediate section.
  5. Remove the pins from the pin holder of the intermediate section, insert them into holes (1) and (2) sideways and secure them using the spring clip.
  6. Establish an electrical connection for the anti-twoblock device and the aircraft warning lamp\* between the 3.8-m-stinger (12.5 ft) and the intermediate section.



### Attaching the second intermediate section

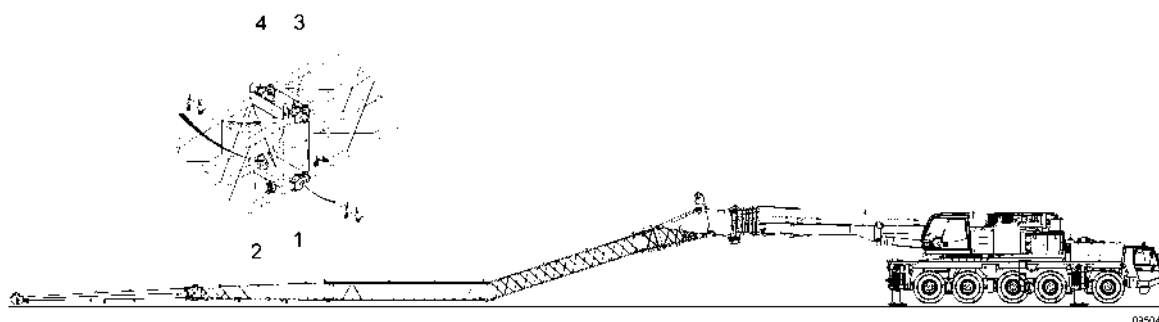

- The 3.8-m-stinger (12.5 ft) is bent to 20°.
  - The hoisting rope is pinned and secured with the rope clamp at the fixing point of the 3.8-m-stinger (12.5 ft).
1. Lower the telescopic boom until the upper holes of the first intermediate section (3) and (4) align with the upper holes of the second intermediate section.
  2. Remove the pins from the pin compartment of the intermediate section, insert them into holes (3) and (4) sideways and secure them using the spring clip.
  3. Raise the telescopic boom carefully until the second intermediate section no longer touches the ground and the lower holes of the first intermediate section align with the lower holes of the second intermediate section.
  4. Remove the pins from the pin compartment of the intermediate section, insert them into holes (1) and (2) sideways and secure them using the spring clip.
  5. Establish an electrical connection for the anti-twoblock device and the aircraft warning lamp\*) between both the intermediate sections.

### Attaching the 6.0-m-stinger foot (19.7 ft) with the boom end

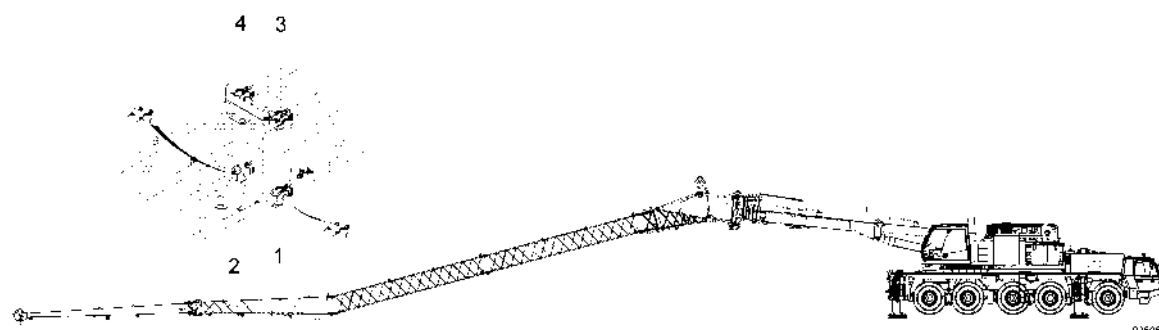

1. Lower the telescopic boom until the upper holes of the intermediate section (3) and (4) are flush with the upper holes of the 6.0-m-fly jib foot (19.7 ft).
2. Remove the pins from the pin compartment of the 6.0-m-fly jib foot (19.7 ft), insert them laterally into holes (3) and (4) and secure them with spring clips.

3. Carefully luff up the telescopic boom until the boom tip no longer touches the ground and the lower holes of the intermediate section are flush with the lower holes of the 6.0-m-fly jib foot (19.7 ft).
4. Remove the pins from the pin compartment of the 6.0-m-fly jib foot (19.7 ft), insert them laterally into holes (1) and (2) and secure them with spring clips.
5. Establish an electrical connection for the anti-twoblock device and the aircraft warning lamp\*) between the intermediate section and the 6.0-m-fly jib foot (19.7 ft).
6. Unwind the hoisting rope under tension along the entire length of the jib.
7. Place the hoisting rope on the sheave of the boom tip. To do this, pull the spring clip, remove the securing clamp and fit the hoisting rope. Secure the hoisting rope again with the securing clamp and spring clip.

#### Finishing work

1. Lift the mobile crane using the rear outriggers again and level it.
2. Mount the anti-twoblock device, *anemometer [page 160]* and *aircraft warning lamp [page 162\*]* on the head of the jib.
3. Guide the hoisting rope through the release weight of the anti-twoblock device.
4. Mount the *bottom block [page 403]*.
5. Enter the setup condition in the automatic safe load indicator.

#### Examples of rope reeving

Depending on the required lifting load, determine the bottom block and the required number of rope falls with the help of "Notes regarding the lifting capacity chart" and the lifting capacity charts.

Reeve the hoisting rope depending on the required number of rope falls as described below:

	If possible, the reeving in the bottom block should be done such that the bottom block is suspended vertically especially in case of a small number of ropes.
---	---

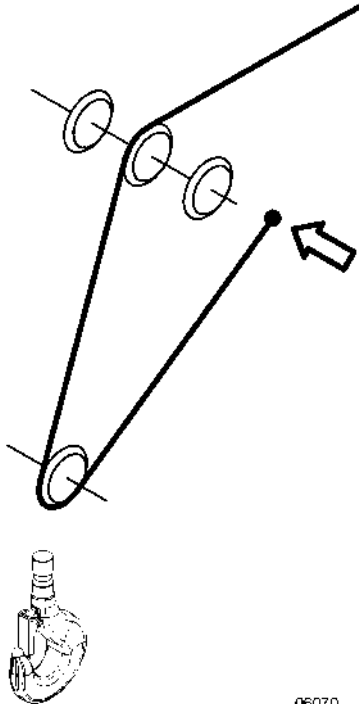
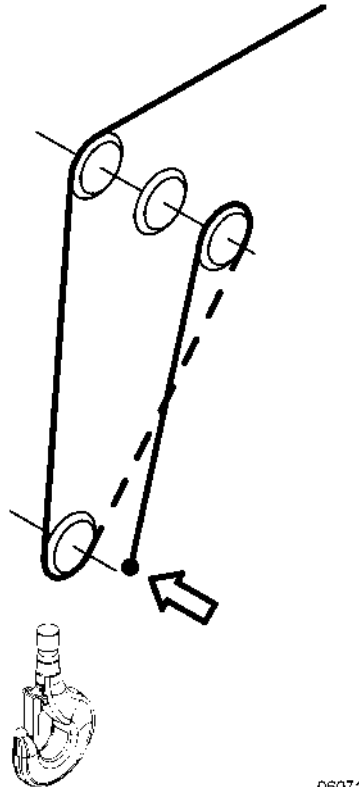

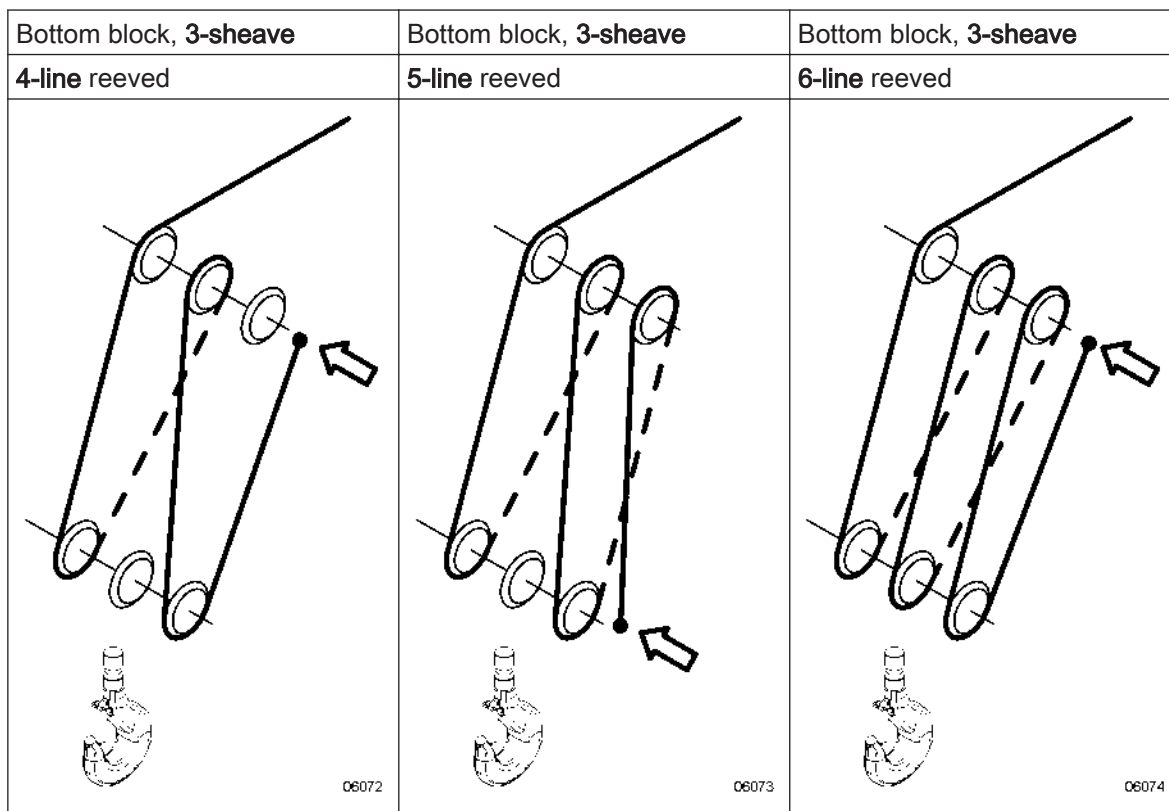
Bottom block, 1-sheave	Bottom block, 1-sheave	Bottom block, 1-sheave
1-line reeved	2-line reeved	3-line reeved
 <p data-bbox="549 920 600 936">06069</p>	 <p data-bbox="963 987 1015 1003">06070</p>	 <p data-bbox="1378 1070 1430 1086">06071</p>
<p data-bbox="400 1160 427 1238"><b>i</b></p>	<p data-bbox="576 1144 1433 1256">If the 3.8 m (12.5 ft) fly jib is at a small angle, the maximum angle of the boom is limited by the automatic safe load indicator to prevent the hoisting rope colliding with the lower sheaves on the boom head.</p>	



#### Removing of the fly jib - transport position

##### Requirements

- The mobile crane is supported as prescribed.
- The slewing gear brake is engaged.
- All telescopes are retracted.
- The superstructure is slewed to the back or side.
- The telescopic boom is luffed down (0° position).
- The jib is luffed up (0° position).
- The bottom block was placed on the ground and decoupled. The rope clamp and the release weight of the anti-two-block device were removed from the hoisting rope.
- The double ladder, crank handle and the remote control for the slewing cylinder are ready.

	 <b>WARNING</b>
	<p><b>Risk of skidding and accident!</b></p> <p>When climbing and stepping on ladders and access ladders, take utmost care especially in case of humid weather.</p> <ol style="list-style-type: none"> <li>1. Always keep the ladders and access ladders clean.</li> <li>2. Remove dirt and other greasy substances immediately and thoroughly.</li> <li>3. Always hold the ladder beams or handles while climbing up or down.</li> <li>4. Wear non-slip shoes and keep them clean.</li> <li>5. Ensure that the ladders are safe.</li> </ol>

### Preparations

1. Remove the anti-twoblock device, anemometer and aircraft warning lamp\*) from the head of the jib. Fit the anti-twoblock device to the 3.8-m-fly jib (12.5 ft), secure the anemometer and aircraft warning lamp\*) to the holder for the anemometer and aircraft warning lamp\*) in the cab.
2. Detach electrical connections for the anti-twoblock device and the aircraft warning lamp\*) between all parts of the jib.
3. When the boom end is dismantled: Remove the hoisting rope from the sheave of the boom end. For this, pull the spring clip, remove the securing clamp and remove the hoisting rope. Insert the securing clamp again and secure it using the spring clip.
4. Remove the hoisting rope from the sheave of the 3.8-m-fly jib (12.5 ft). For this, pull the spring clip, remove the securing clamp and remove the hoisting rope. Insert the securing clamp again and secure it using the spring clip.
5. Start the superstructure engine.
6. Activate the  setup mode in the automatic safe load indicator.
7. Wind in the hoisting rope under tension until the rope end projects beyond the telescopic boom and stow it to the side.
8. Switch off the superstructure engine.

### Removing the boom tip

1. Fix the guide belt on the head of the boom end.

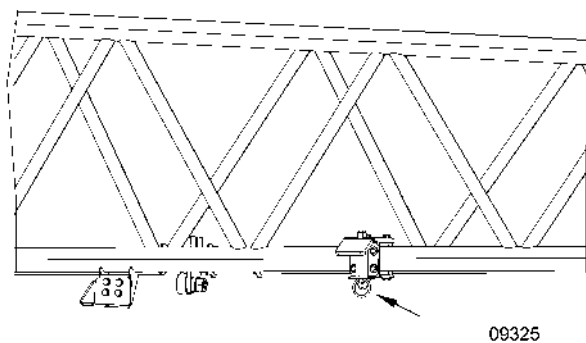

- Loosen the lock. For this, pull the retaining spring washer (using the crank handle) and turn it by 90°.

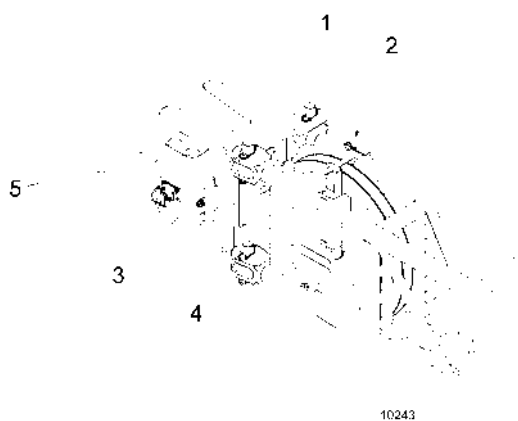

- Remove pins from holes (3) and (4). For this, pull the spring clip, pull out the pins, insert them into the pin compartment (5) and secure them.

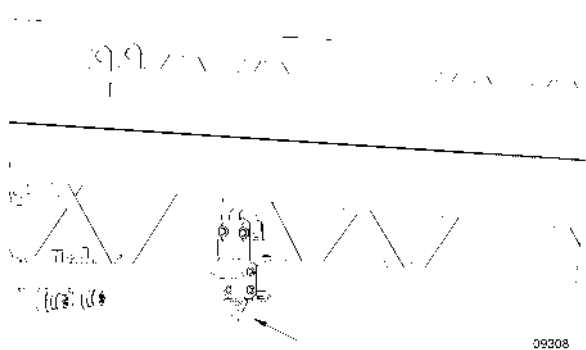

- Slew back the boom end using the guide belt until the lock engages.  
⇒ The boom tip is fixed on the 6.0-m-fly jib foot (19.7 ft).
- Loosen the guide belt from the boom tip.

## Removing the fly jib

### Preparing the transporting support

➤ Electrical connections for the anti-twoblock device and the aircraft warning lamp\*) is disconnected.

1. Fix the guide belt on the head of the 6.0-m-stinger foot (19.7 ft).

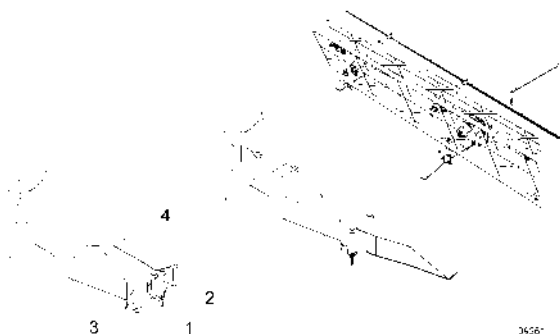

2. Fold out the middle transporting support. Remove the folding plug (1) and pull the bolt (2) downwards. Fold out the transporting support extension (4), insert the bolt (2) in the hole (3) from bottom and secure using the folding plug (1).

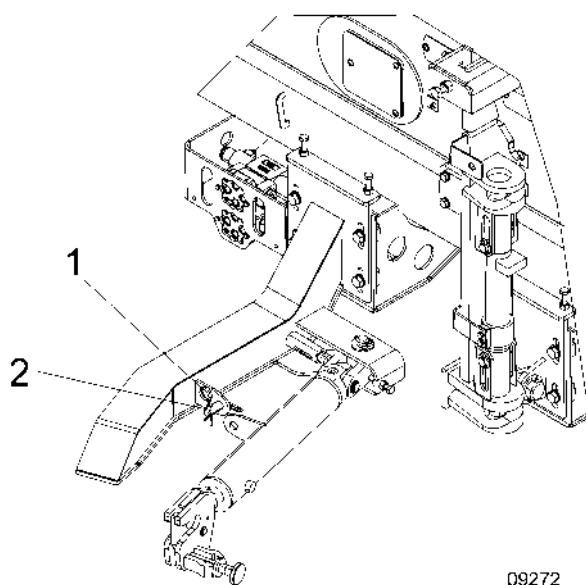

3. Loosen the pin between the slewing cylinder and the transporting support. Pull the spring clip (1) and bolt (2) for this. Press the slewing cylinder to the right. Re-insert the bolt (2) into the hole of the transporting support and secure using the spring clip (1).

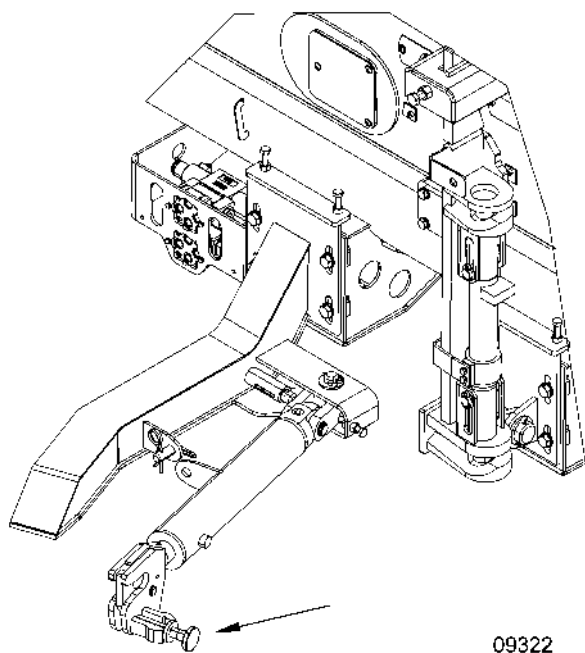

4. Pull the lock on the slewing cylinder until the hook lock opens.
5. Connect the remote control.
6. Start the superstructure engine.

#### Removing the hoisting rope

1. Extend the slewing cylinder completely using the remote control (the right lever to the front).
2. Due to the dead weight of the fly jib, the upper threaded bolt cannot yet be unscrewed from the upper hole of the bearing bracket. To do this, lift the fly jib slightly using the hoisting gear, after the hoisting rope has been positioned and fixed to the rope fixing point of the 6.0-m-fly jib foot (19.7 ft).

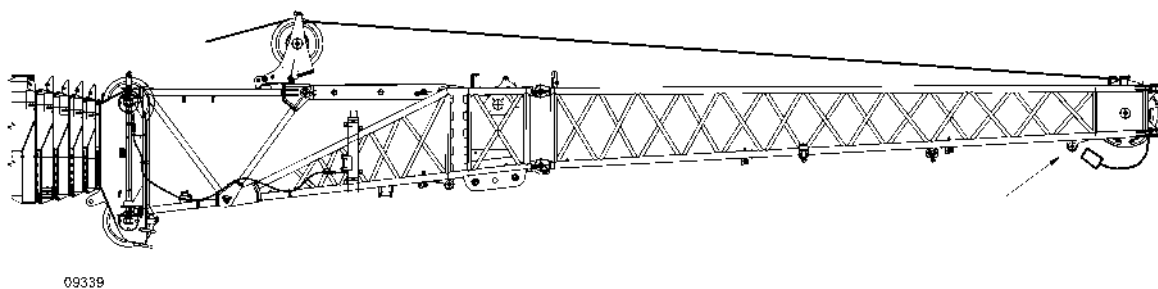



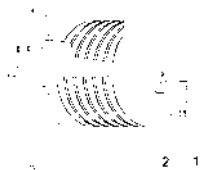

3. Check the lock on the left-hand side of the boom head. Pin (2) must point towards the telescopic boom. **⚠️ DANGER! If the lock is not engaged, the fly jib may pivot out uncontrollably when pins are removed.**
4. Loosen the pin on the left side of the boom head. Insert the crank handle into the threaded bolt and turn it up to the end stop.  
**NOTICE! The upper and lower bolt elements must be extended from the holes of bearing brackets on the boom head.**
5. Remove the crank handle again.
6. Release the hoisting rope from the rope fixing point on the 6.0-m-fly jib foot (19.7 ft), wind it up under tension until the end of the rope protrudes over the boom head and stow it to the side. For this, pull the spring clip, remove the securing clamp and remove the hoisting rope. Refit the securing clamp and secure with the spring clip. Next, take the hoisting rope from the sheave on the 3.8-m-fly jib (12.5 ft) by pushing the securing clamp down and turning it to the locked position. Turn the securing clamp back up once you have taken out the hoisting rope.  
**NOTICE! Do not drag the hoisting rope on the ground.**

#### Connecting the fly jib with the locking cylinder

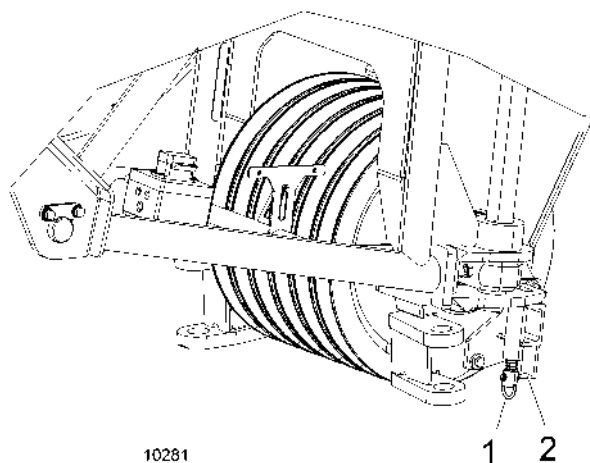

1. Loosen the lock on the left side of the boom head. For this, pull the ring (1) down and turn it by 90°.

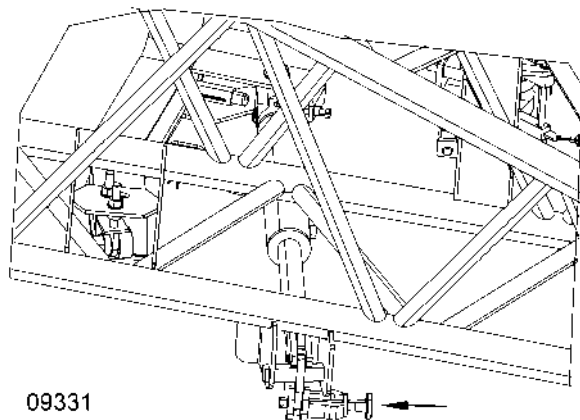

2. Slew back the stinger using the guide belt until it engages in the lock of the slewing cylinder.

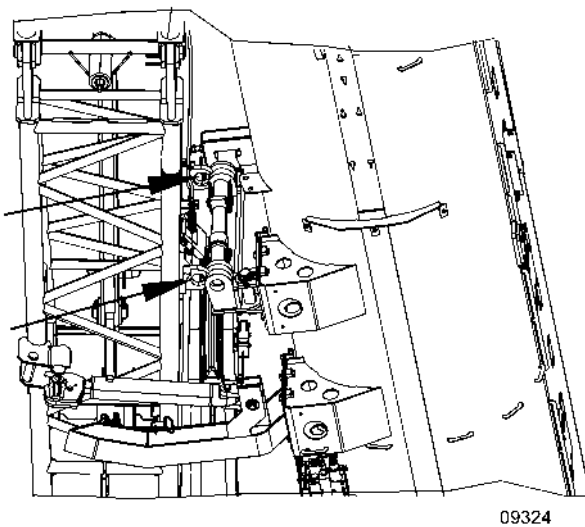

3. Retract the slewing cylinder using the remote control (the right lever to the back) until the holes on the locking cylinder align with the holes on the 6.0-m-stinger foot (19.7 ft).
4. Pin the stinger with the telescopic boom. Extend the locking bolts using the remote control (the left lever to the front). **⚠️ WARNING! The locking cylinder must be extended completely. If the locking cylinder is not fully extended, the fly jib may fall.**

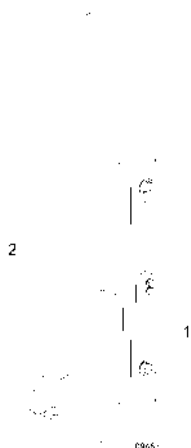

5. Check whether the locking cylinder is extended completely. The height of the tip of the indicator arrow (1) and the tip of the red marking (2) must be the same.

### Releasing the fly jib from the boom head

1. Release the slewing cylinder. Extend the slewing cylinder by 1 to 2 mm (0.039-0.078 in) using the remote control (the right lever to the front).

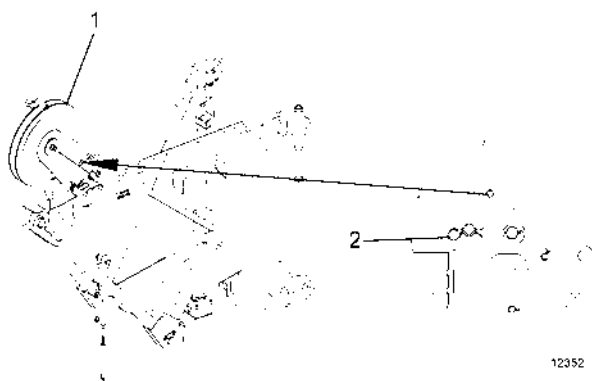

2. Remove spring clips and pins.
3. Wind down the sheave on the 3.8-m-stinger (12.5 ft) up to the end stop using the crank handle.

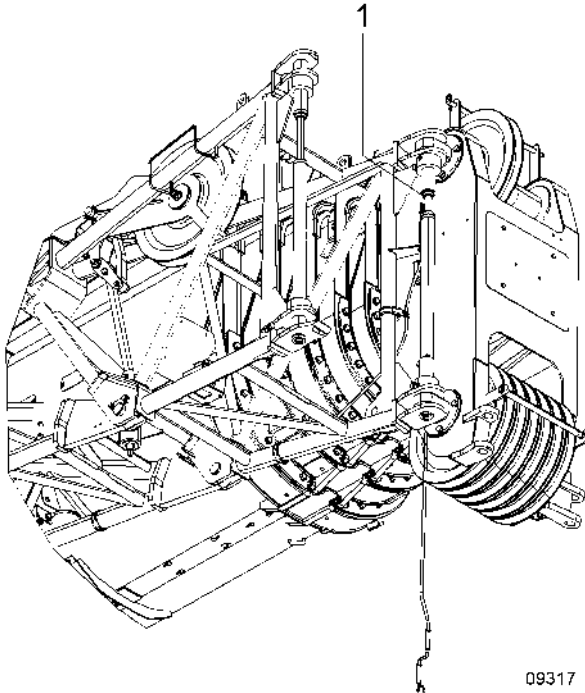

4. Loosen the pin on the right side of the boom head. Insert the crank handle into the threaded bolt and turn it up to the end stop. **NOTICE! The upper and lower bolt elements must be extended from the holes of bearing brackets on the boom head.**

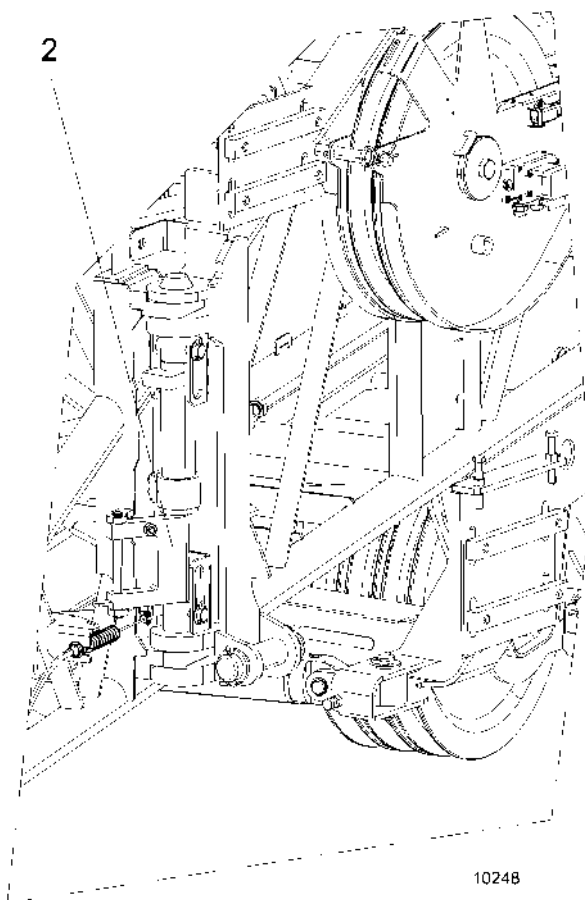

⇒ The safety flap (2) is fixed on the locking cylinder.

5. Remove the crank handle again.
6. Retract the slewing cylinder up to the end stop using the remote control (the right lever to the back).

### Pinning the fly jib on the telescopic boom

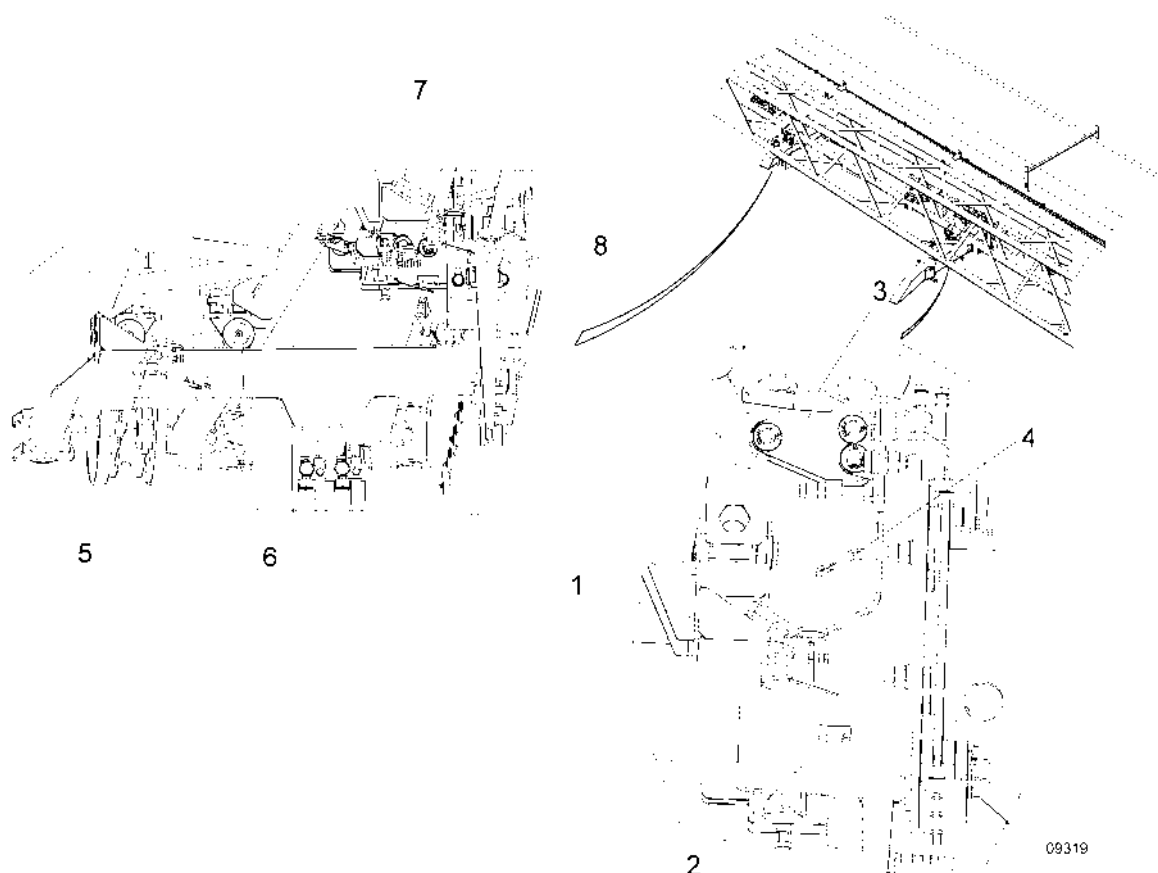

1. Fix the pins (1) and (3) on the **middle** transporting support.  
 Pull the locking pin from the pin holder (2), insert it into the hole (1) and secure it again using the spring clip.  
 Pull the locking pin from the pin holder (4), insert it into the hole (3) and secure it again using the spring clip.
2. Fix the pins (5) and (7) on the **rear** transporting support.  
 Pull the locking pin from the pin holder (6), insert it into the hole (5) and secure it again using the spring clip.  
 Pull the locking pin from the pin holder (8), insert it into the hole (7) and secure it again using the spring clip.
3. Remove the guide belt from the 6.0-m-stinger foot (19.7 ft).
4. Switch off the engine and the ignition.
5. Detach the remote control.
6. Fold back the middle transporting support, pin and secure it.

#### Installing the fly jib on the mobile crane - transport position

The following section describes the installation of the 3-piece fly jib to the telescopic boom of the mobile crane.

	<b>⚠ WARNING</b>
	<p><b>Risk of accident!</b> An incorrectly bolted jib may come off and fall on the ground. In the driving mode, all parts of the stinger must be locked and bolted together as well as bolted on the base boom.</p> <ol style="list-style-type: none"><li>1. Always ensure that all lock pins, retaining pins and swivel pins are in the prescribed positions.</li></ol>

#### Requirements

- The mobile crane is supported as prescribed.
- The slewing gear brake is engaged.
- All telescopes are retracted.
- The superstructure is slewed to the back or side.
- The telescopic boom is set horizontally ( $\pm 1^\circ$ ).

**⚠ WARNING!** In case of larger angles, there is a risk of accident and personal injuries.

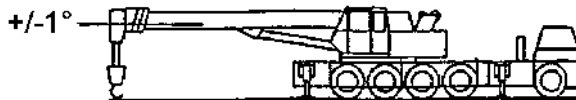

09412

- Parts of the stinger are corrected bolted with each other using lock pins.
- The double ladder, crank handle and the remote control for the slewing cylinder/locking cylinder are ready.

	<b>⚠ WARNING</b>
	<p><b>Risk of skidding and accident!</b> When climbing and stepping on ladders and access ladders, take utmost care especially in case of humid weather.</p> <ol style="list-style-type: none"><li>1. Always keep the ladders and access ladders clean.</li><li>2. Remove dirt and other greasy substances immediately and thoroughly.</li><li>3. Always hold the ladder beams or handles while climbing up or down.</li><li>4. Wear non-slip shoes and keep them clean.</li><li>5. Ensure that the ladders are safe.</li></ol>

### Preparing the transporting support

1. Fix the guide belt on the head of the 6.0-m-stinger foot (19.7 ft).

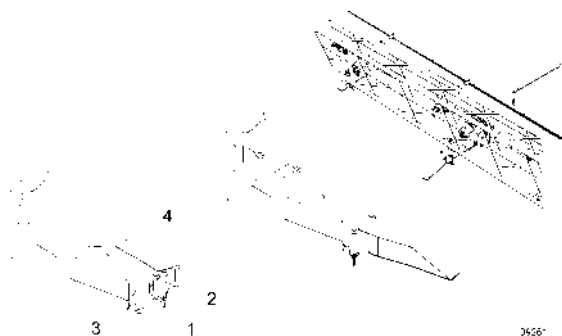

2. Fold out the middle transporting support. Remove the folding plug (1) and pull the bolt (2) downwards. Fold out the transporting support extension (4), insert the bolt (2) in the hole (3) from bottom and secure using the folding plug (1).

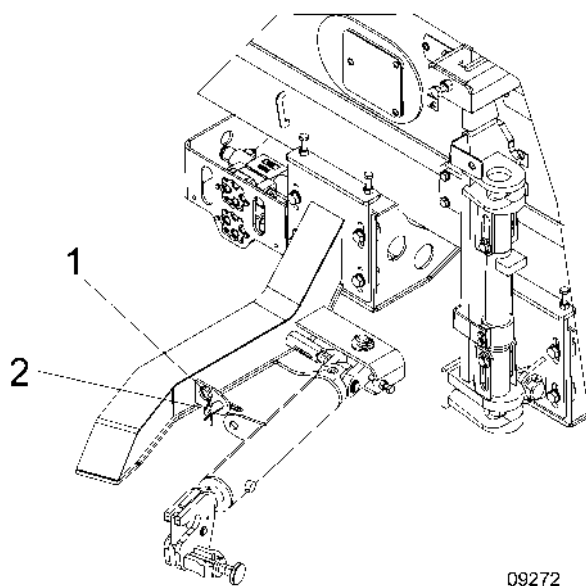

3. Loosen the pin between the slewing cylinder and the transporting support. Pull the spring clip (1) and bolt (2) for this. Press the slewing cylinder to the right. Re-insert the bolt (2) into the hole of the transporting support and secure using the spring clip (1).

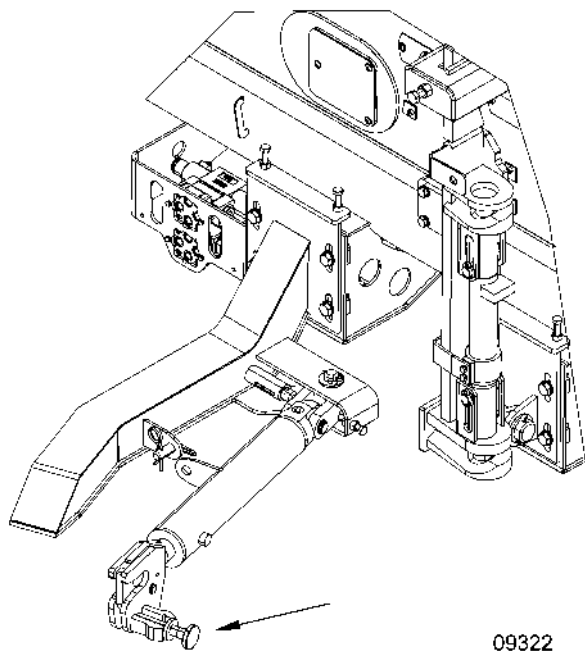

4. Pull the lock on the slewing cylinder until the hook lock opens.
5. Connect the remote control.
6. Switch on the battery main switch and the ignition in the crane cab. Start the superstructure engine.
7. Activate the  setup mode in the automatic safe load indicator.

#### Bolting one side of the fly jib to the boom head

1. Lift the 18-m-fly jib (59.1 ft) with the roller carrier using the auxiliary crane.  
Use suitable slinging aids, see *Slings points on fly jib* [page 256].

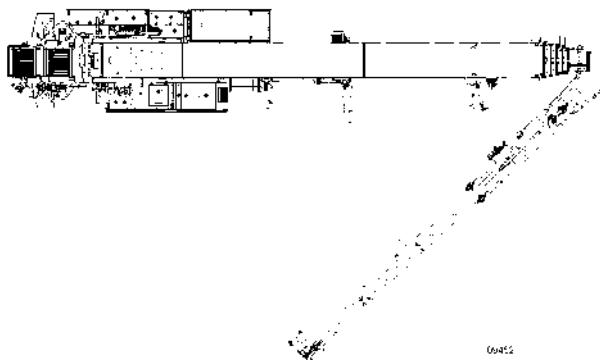

2. Adjust the fly jib on the telescopic boom so that the holes of the 3.8-m-fly jib (12.5 ft) are aligned on the right side of the boom head.



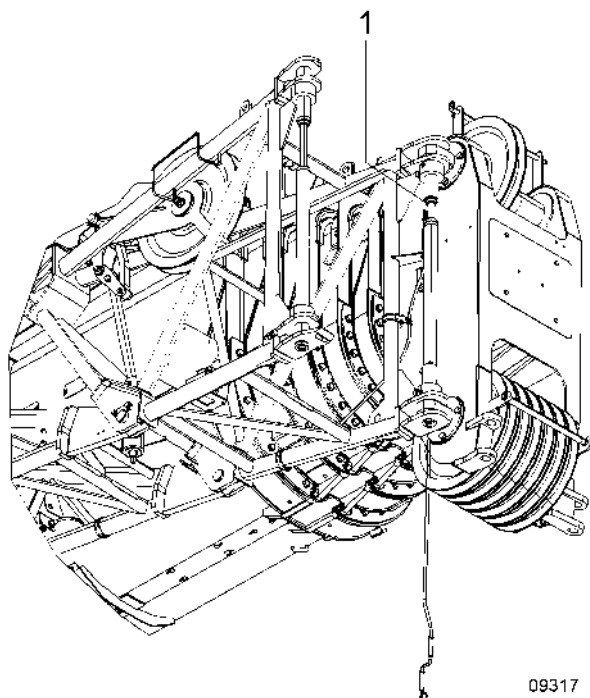

3. Insert the crank handle into the threaded bolt and turn until the third red marking (1) is completely visible. **⚠️ WARNING!** The upper and lower bolt elements must be retracted completely (up to the end stop) in the bearing brackets on the boom head. Since both bolt ends are not retracted completely, the stinger may fall.
4. Remove the crank handle again.
5. Detach the sling gear from the lifting eyes of the fly jib.

#### Connecting the fly jib with the locking cylinder

1. Extend the slewing cylinder completely using the remote control (the right lever to the front).

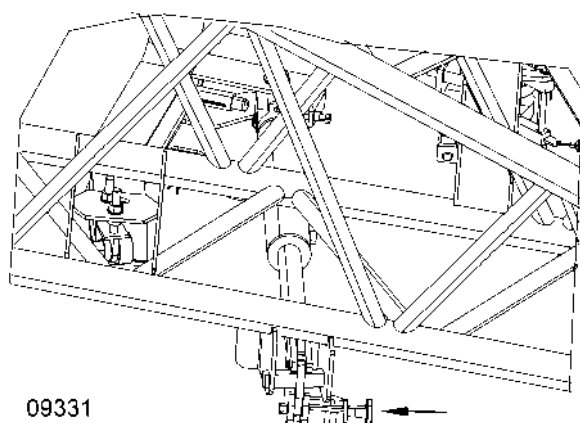

2. Slew back the stinger using the guide belt until it engages in the lock of the slewing cylinder.

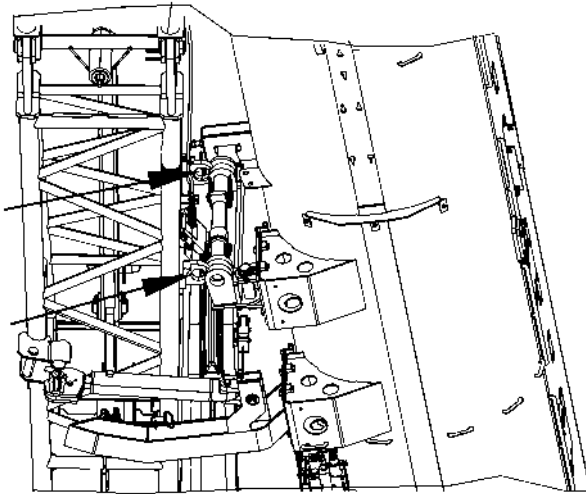

09324

3. Retract the slewing cylinder using the remote control (the right lever to the back) until the holes on the locking cylinder align with the holes on the stinger foot.
4. Pin the stinger with the telescopic boom. Extend the locking bolts using the remote control (the left lever to the front). **⚠️ WARNING! The locking cylinder must be extended completely. If the locking cylinder is not fully extended, the fly jib may fall.**



5. Check whether the locking cylinder is extended completely. The height of the tip of the indicator arrow (1) and the tip of the red marking (2) must be the same.

### Releasing the fly jib from the boom head

1. Release the slewing cylinder. Extend the slewing cylinder by 1 to 2 mm (0.039-0.078 in) using the remote control (the right lever to the front).

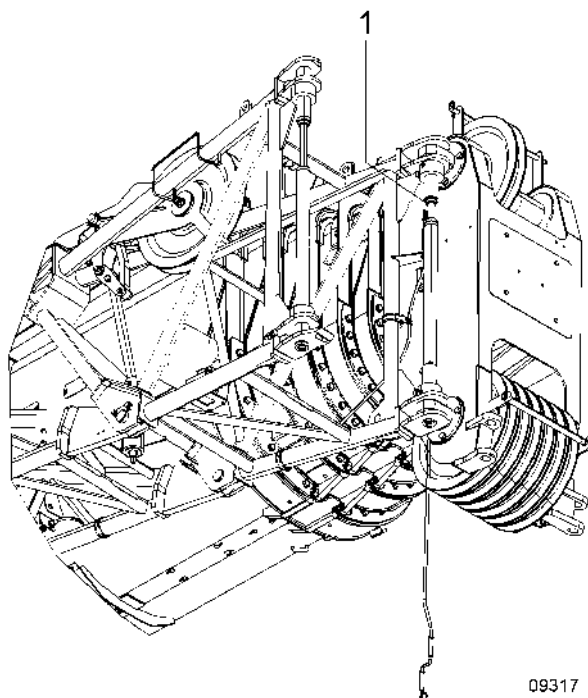

2. Loosen the pin on the right side of the boom head. Insert the crank handle into the threaded bolt and turn it up to the end stop. **NOTICE! The upper and lower bolt elements must be extended from the holes of bearing brackets on the boom head.**
  - ⇒ The safety flap (2) is fixed on the locking cylinder.

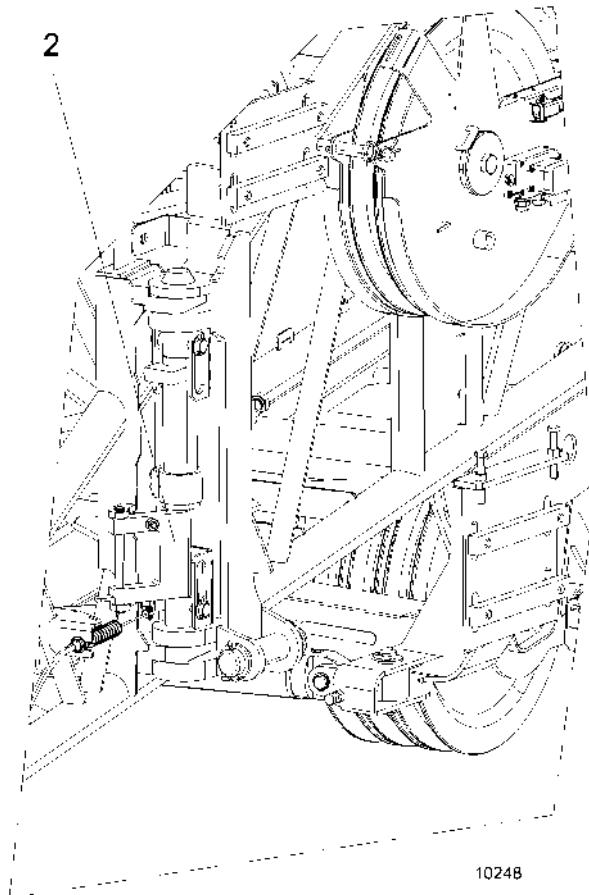

3. Remove the crank handle again.
4. Retract the slewing cylinder up to the end stop using the remote control (the right lever to the back).

### Pin the fly jib on the telescopic boom

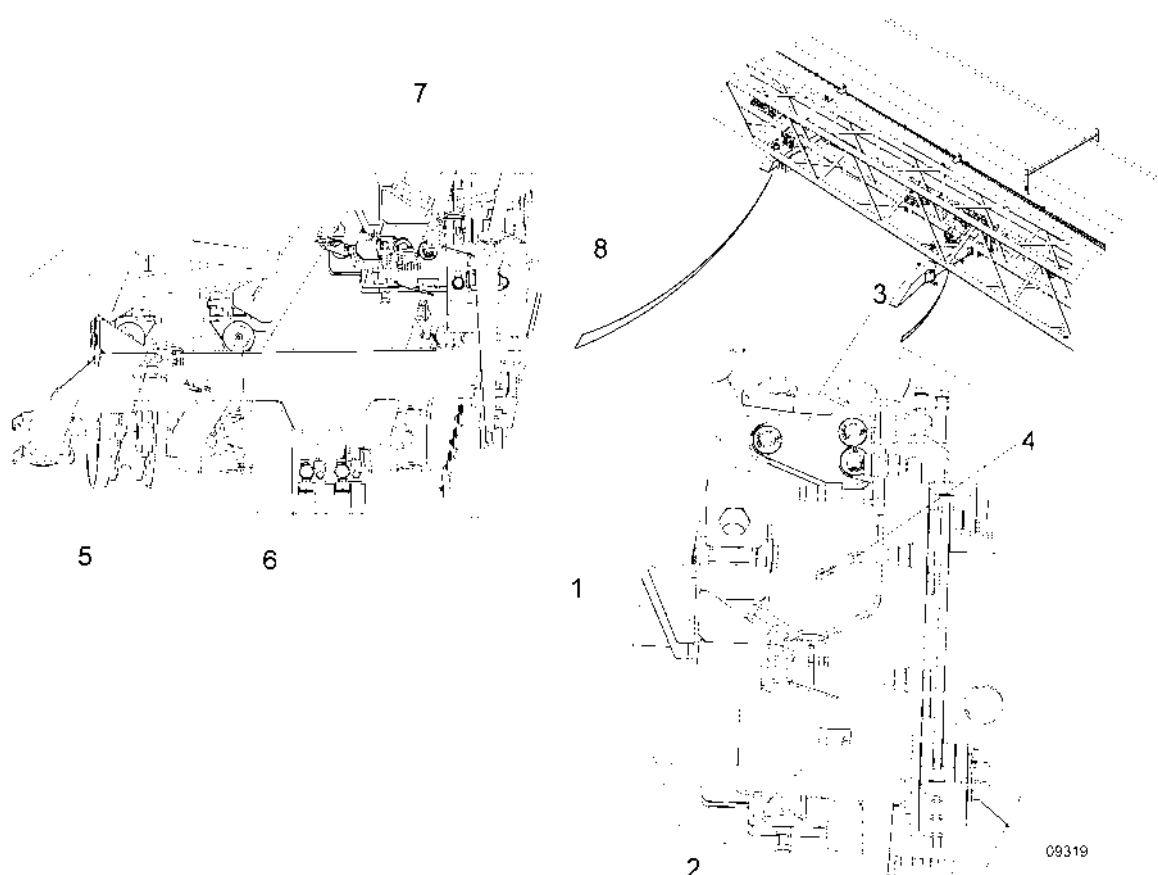

1. Fix the pins (1) and (3) on the **middle** transporting support.  
 Pull the lock pin from the pin compartment (2), insert it into the hole (1) and secure it again using the spring clip.  
 Pull the lock pin from the pin compartment (4), insert it into the hole (3) and secure it again using the spring clip.
2. Fix the pins (5) and (7) on the **rear** transporting support.  
 Pull the lock pin from the pin compartment (6), insert it into the hole (5) and secure it again using the spring clip.  
 Pull the lock pin from the pin compartment (8), insert it into the hole (7) and secure it again using the spring clip.
3. Switch off the engine and the ignition.
4. Detach the remote control.
5. Remove the guide belt.
6. Fold back the middle transporting support, pin and secure it.

### Detaching the fly jib

The fly jib is detached in the reverse order.

	<b>NOTICE</b>
	<p><b>Fly jib set down incorrectly!</b>                  If the fly jib is set down on dirty ground or too quickly, it may be damaged.</p> <ol style="list-style-type: none"> <li>1. Once it has been detached, always place the fly jib on timbers or trestles with sufficient load-bearing capacity.</li> <li>2. Set the fly jib down slowly and carefully.</li> </ol>

**Hydraulically angled fly jib\*)**

The fly jib consists of 3 parts and can be extended with max. 2 intermediate pieces.

For information about angling the fly jib hydraulically, see *Assigning the crane control levers [page 204]*.

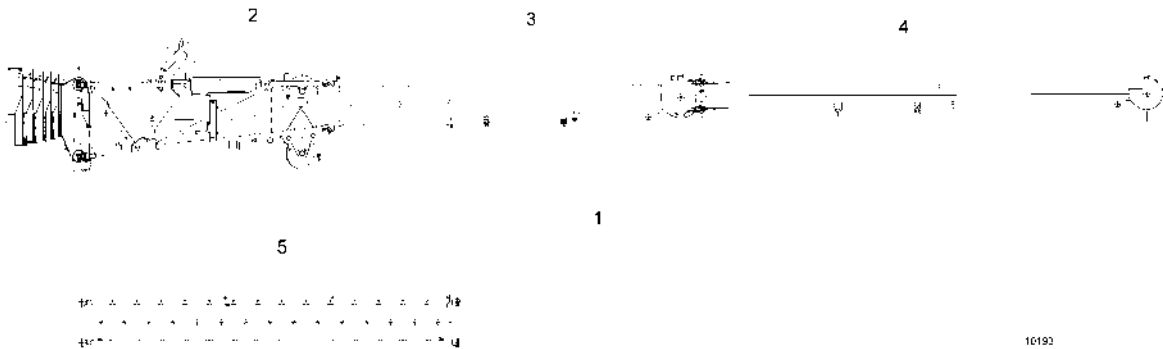



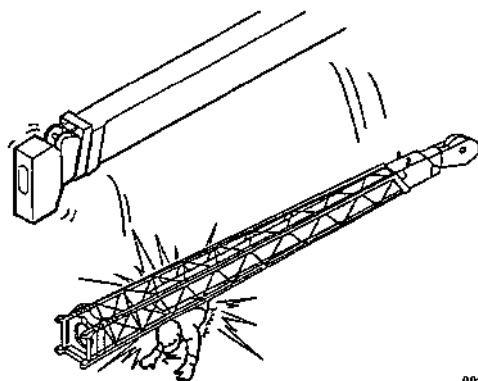

1	3-piece fly jib, 18 m (59.1 ft), with roller carrier	4	7.5-m-boom tip (24.6 ft)
2	3.8-m-fly jib (12.5 ft), with roller carrier	5	7.0-m-intermediate section (23.0 ft)
3	6-m-stinger foot (19.7 ft)		

	<b>⚠ DANGER</b>
	<p><b>Danger due to falling jib!</b>                  An incorrectly bolted jib may come off and fall on the ground. Persons under or in the range of the jib may get injured.</p> <ol style="list-style-type: none"> <li>1. Always ensure that all lock pins, retaining pins and swivel pins are in the prescribed positions.</li> <li>2. Ensure that nobody is present in the slewing range of the jib when carrying out rigging work.</li> </ol>



99127

	<p><b>! DANGER</b></p> <p><b>Risk of falling!</b> When working at heights, installation personnel may fall and be seriously or fatally injured.</p> <ol style="list-style-type: none"> <li>1. Make sure that personnel cannot fall with suitable aids for installation and dismantling work (e.g. work platform, railing).</li> <li>2. Use the available access steps and double ladder that are provided.</li> </ol>
	<p><b>! WARNING</b></p> <p><b>Risk of skidding and accident!</b> When climbing and stepping on ladders and access ladders, take utmost care especially in case of humid weather.</p> <ol style="list-style-type: none"> <li>1. Always keep the ladders and access ladders clean.</li> <li>2. Remove dirt and other greasy substances immediately and thoroughly.</li> <li>3. Always hold the ladder beams or handles while climbing up or down.</li> <li>4. Wear non-slip shoes and keep them clean.</li> <li>5. Ensure that the ladders are safe.</li> </ol>
	<p><b>! DANGER</b></p> <p><b>Overloading of the mobile crane!</b> Lifting the loads on the ground by raising the boom can lead to boom overload or can also cause the crane to tilt. Raising movements are not switched off via the automatic safe load indicator.</p> <ul style="list-style-type: none"> <li>▶ Loads may not be dragged.</li> </ul> <ol style="list-style-type: none"> <li>1. Carry out load movements only using the hoisting winch.</li> <li>2. Lift the loads only vertically.</li> </ol>

	<p><b>NOTICE</b></p> <p><b>Slewing range too small!</b>                  If the slewing range of the jib has buildings, trees or other obstacles, collisions may occur when slewing and it will lead to damage.</p> <ol style="list-style-type: none"> <li>1. Select a suitable location for mounting the jib.</li> </ol>
<p><b>i</b></p>	<p>When operating the crane with the jib folded in the transport position on the telescopic boom or when working using the telescopic boom with the attached jib, the bearing loads specified in the lifting capacity charts are reduced by the values specified in the notes regarding the lifting capacity charts.</p>
<p><b>i</b></p>	<p>The automatic safe load indicator has a setup mode for installing and dismantling the jib. In this setup mode, the anti-twoblock device has automatic bridging. The operation should be carried out in unloaded condition and with utmost care.</p>
<p><b>i</b></p>	<p>The slewing range is increased after mounting the jib.</p> <ol style="list-style-type: none"> <li>1. Attach the counterweights in advance.</li> </ol>

**Sling points on fly jib**

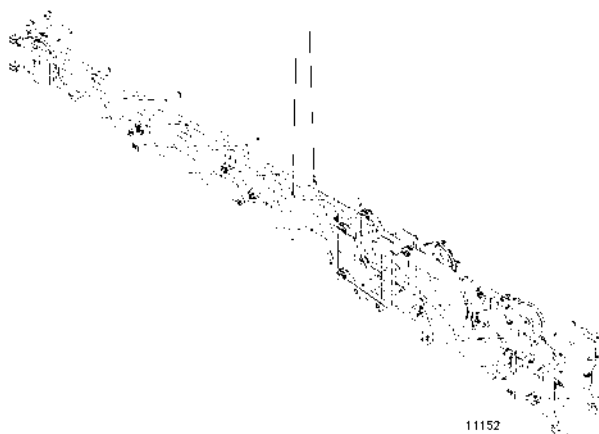



3-piece fly jib, 18 m (59.1 ft) (approx. 1830 kg (4034.6 lbs)).

Suitable slinging aids: Chains or ropes.

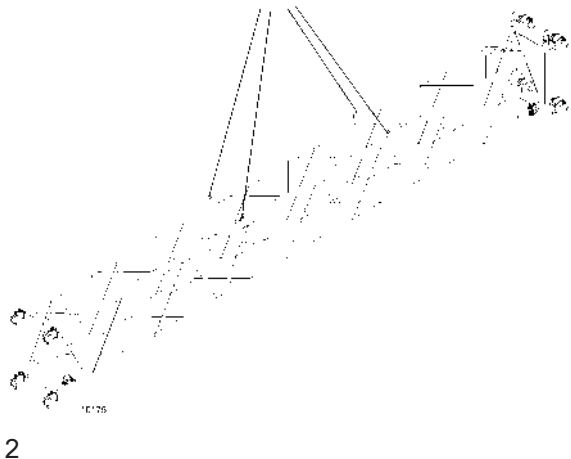
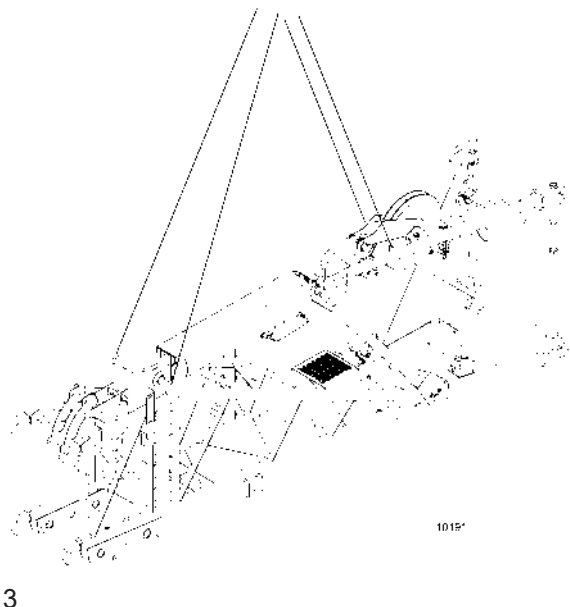
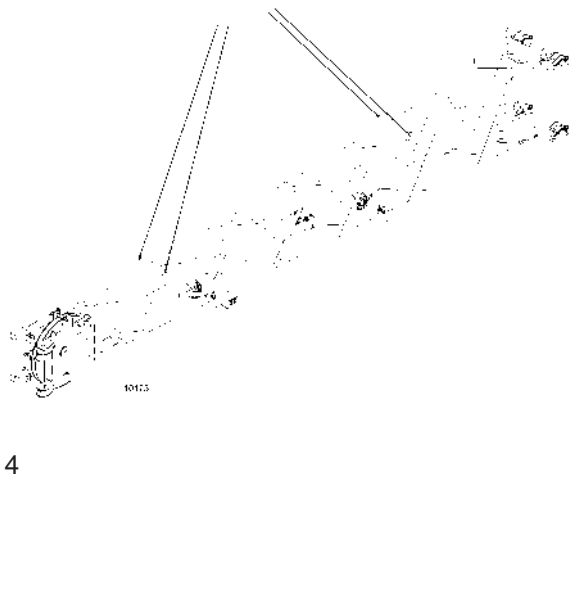
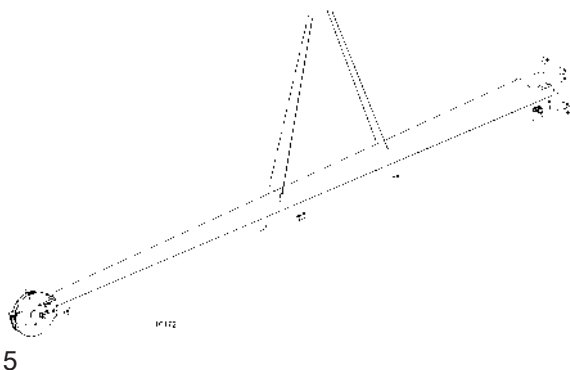

 <p>1</p>	 <p>2</p>
 <p>3</p>	 <p>4</p>
 <p>5</p>	
<p>1 2-piece stinger, 10 m (32.8 ft) (approx. 1410 kg (3108.5 lbs))</p>	<p>2 7-m-intermediate section (23.0 ft) (approx. 480 kg (1058.2 lbs))</p>
<p>3 3.8-m-fly jib (12.5 ft) (approx. 950 kg (2094.4 lbs))</p>	<p>4 6-m-fly jib foot (19.7 ft) (approx. 460 kg (1014.1 lbs))</p>
<p>5 7.5-m-boom tip (24.6 ft) (approx. 420 kg (926.0 lbs))</p>	

	<p><b>⚠ DANGER</b></p> <p><b>Incorrect slinging aids used!</b>                  The jib may fall on the ground if unsuitable slinging aids are used. This may damage the jib. Persons under the jib may get injured.</p> <p>1. Fix a suitable slinging aid to the lifting lugs of the stinger.</p>
	<p><b>⚠ DANGER</b></p> <p><b>Incorrect slinging points used!</b>                  If the wrong slinging points are used, the jib may become unstable. This may damage the jib. Persons under the jib may get injured.</p> <p>1. Use the specified slinging points when attaching the jib.</p>

**Description of remote control**

The telescopic boom is equipped with a hydraulic folding aid and a hydraulic locking bolt for the jib. A remote control is used for controlling them.

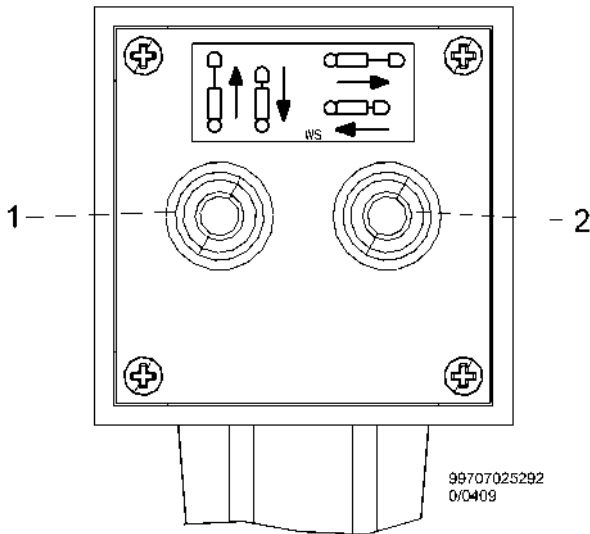

<p>1 Lock/unlock connecting bolt:                  Lever to the front: lock the connecting bolt                  Lever to the back: unlock the connecting bolt</p>	<p>2 Retract/extend slewing cylinder:                  Lever to the front: extend the slewing cylinder                  Lever to the back: retract the slewing cylinder</p>
--	---

## Connecting the remote control

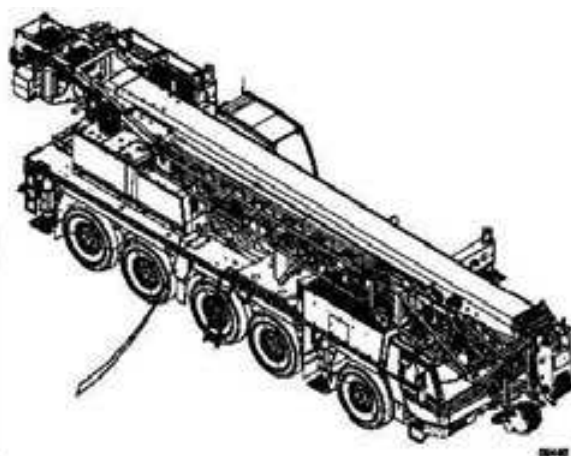

1. Connect the remote control at the front-right on the superstructure.

## Working with the 18-m-stinger foot (59.1 ft)

The following section describes the structure of the 3-piece fly jib, i.e. the hydraulically angled 3.8-m-fly jib (12.5 ft), 6.0-m-fly jib foot (19.7 ft) and the 7.5-m-boom tip (24.6 ft).



### Requirements

- The mobile crane is supported as prescribed.
- Counterweights required for the crane operation are attached.
- The slewing gear brake is engaged.
- All telescopes are retracted.
- The superstructure is slewed to the back or side.
- The telescopic boom is set horizontally ( $\pm 1^\circ$ ).

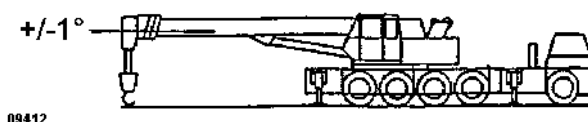
**⚠ WARNING!** In case of larger angles, there is a risk of accident and personal injuries.





- The stinger (3-piece) is mounted at the transport position on the telescopic boom.
- The hydraulic lines from the luffing jib are connected to the mobile crane.
- The bottom block was placed on the ground and decoupled. The rope clamp and the release weight of the anti-twoblock device were removed from the hoisting rope. **NOTICE!** This point is not necessary for crane work using hoisting gear 1 via the boom head or hoisting gear 2 via the jib.
- The double ladder, crank handle and the remote control for the slewing cylinder are ready.

	 <b>WARNING</b>
	<p><b>Risk of skidding and accident!</b></p> <p>When climbing and stepping on ladders and access ladders, take utmost care especially in case of humid weather.</p> <ol style="list-style-type: none"> <li>1. Always keep the ladders and access ladders clean.</li> <li>2. Remove dirt and other greasy substances immediately and thoroughly.</li> <li>3. Always hold the ladder beams or handles while climbing up or down.</li> <li>4. Wear non-slip shoes and keep them clean.</li> <li>5. Ensure that the ladders are safe.</li> </ol>

- The pressure gauge on the hydraulic cylinder shows more than 100 bar (1450.4 psi).

**Checking the hydraulic oil pressure in the hydraulic cylinder of the fly jib**

	 <b>WARNING</b>
	<p><b>Insufficient pressure in the hydraulic cylinder!</b></p> <p>If the pressure in the hydraulic cylinder is too low, the jib may fold down uncontrollably when it is being fitted to the boom or pivoted out.</p> <ol style="list-style-type: none"> <li>1. Every time the jib is to be fitted or pivoted out, you must first check that the pressure in the hydraulic cylinder is more than 100 bar (1,450.4 PSI).</li> <li>2. If the pressure shown is less than 100 bar (1,450.4 PSI), the jib must not be fitted or pivoted out.</li> </ol>

There is a pressure gauge under the hydraulic cylinder (1) for the hydraulically angled jib.

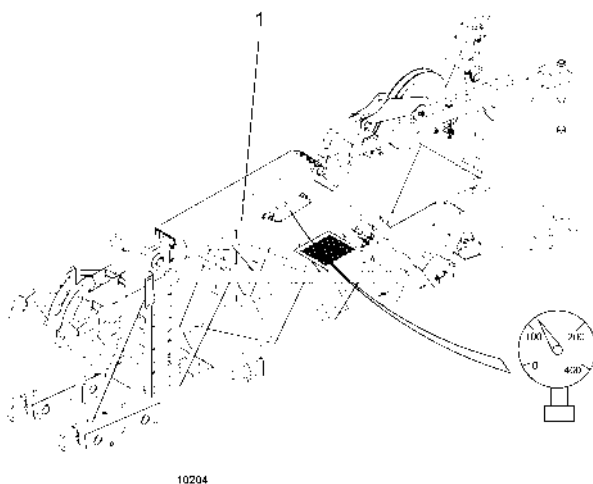



If the pressure gauge shows a pressure of less than 100 bar (1450.4 psi), the pressure must be increased.

To build up the pressure in the hydraulic cylinder, proceed as follows:

1. Switch on the battery main switch and the ignition in the crane cab. Start the superstructure engine.
2. Operate the "Activate jib luffing" rocker switch.
3. Carefully operate the crane control lever in the "Raise luffing jib" function until the pressure gauge shows a pressure of more than 100 bar (1450.4 psi).

The "Jib, luffing cylinder not retracted" warning lamp must not light up as you do this.

- The "Jib luffing cylinder not retracted" warning lamp does not light up.

	 <b>WARNING</b>
	<p><b>"Jib luffing cylinder not retracted" warning lamp lights up!</b></p> <p>If the "Jib luffing cylinder not retracted" warning lamp lights up, the luffing jib cannot be correctly fitted to the boom. This may cause the jib to drop and people may be injured.</p> <ol style="list-style-type: none"> <li>1. Before fitting the jib to the boom, check the "Jib luffing cylinder not retracted" warning lamp.</li> <li>2. Do not fit the luffing jib if the warning lamp is lit.</li> </ol>

To check the "Jib luffing cylinder not retracted" warning lamp, proceed as follows:

1. Start the superstructure engine.
2. Operate the "Activate jib luffing" rocker switch.
3. If the "Jib, luffing cylinder not retracted" warning lamp does **not** light up, the jib can be attached and pivoted out.
4. If the "Jib, luffing cylinder not retracted" warning lamp lights up, carefully operate the "Raise luffing jib" function on the crane control lever until the warning lamp goes out.



Further prerequisite:

- The hydraulic connections on the hose drum are in the working position.

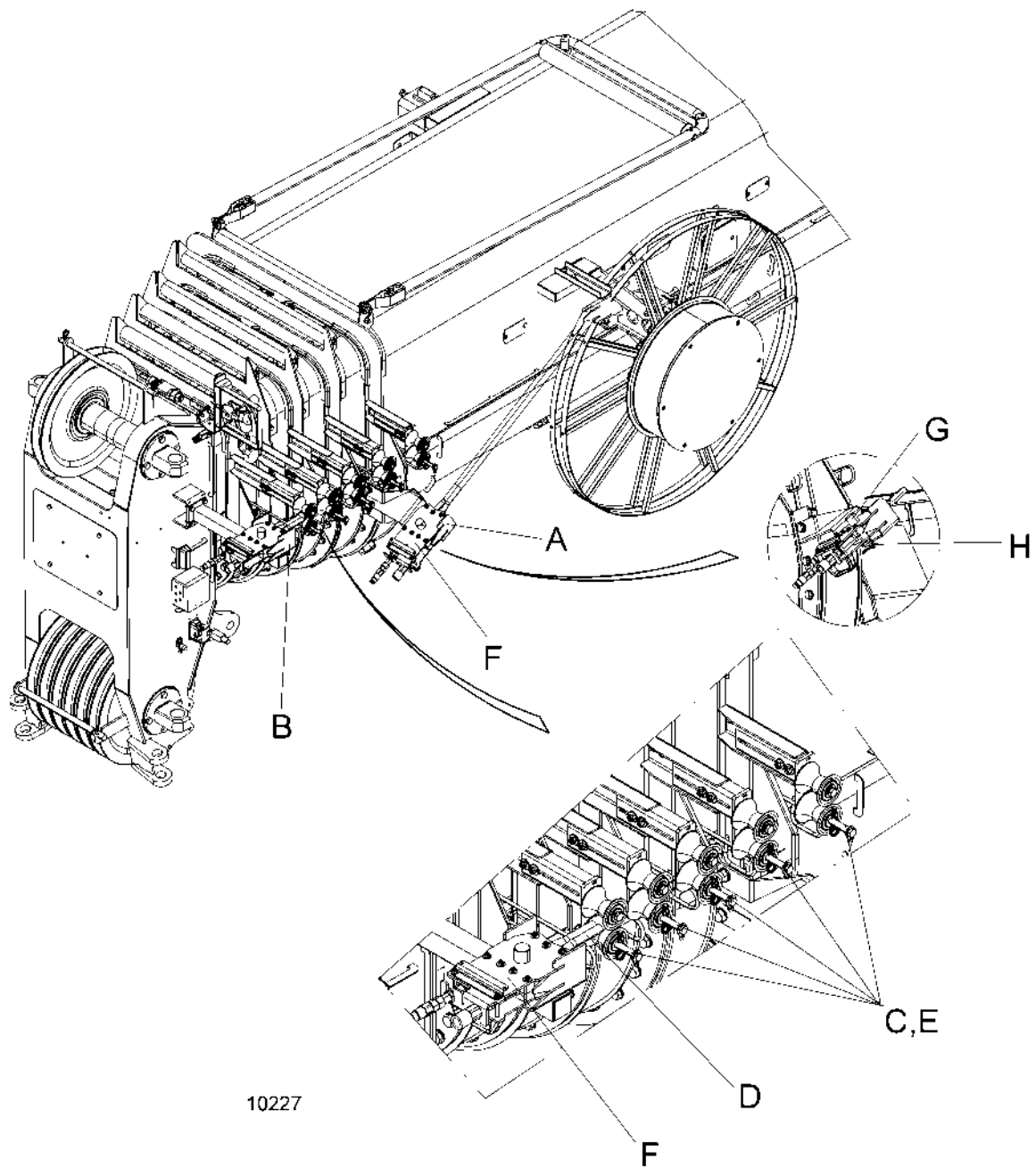
#### Bringing the hydraulic connections into the working position



A	Transport position	E	Guide pulleys
B	Working position	F	Console with hydraulic connector
C	Spring clip	G	Pin
D	Hydraulic lines	H	Spring clip

	 <b>WARNING</b>
	<p><b>Risk of accident from rebounding hydraulic lines!</b></p> <p>The hose drum is under spring tension. People could be injured if the console with hydraulic connector (F) is released.</p> <ol style="list-style-type: none"> <li>1. Use the double ladder.</li> <li>2. Make sure you have a firm footing when moving the console with hydraulic connector (F).</li> <li>3. Make sure you have a firm hold on the console with hydraulic connector (F).</li> </ol>

1. Release the spring clip (C) and move the guide pulleys (E).
2. Take the console with hydraulic connector (F) out of the transport position (A). To do this, pull the spring clip (H) and pin (G).
3. Insert the console with hydraulic connector (F) into the working position (B) and secure with the pin (G) and spring clip (H).
4. Thread the hydraulic lines (D) into the guide. Slide the guide pulleys (E) back and secure with the spring clip (C).

**The hydraulic connections on the hose drum are now in the working position.**

The hose drum is returned to the transport position in the reverse order.

### Bringing the fly jib into the working position

#### Preparations

1. Switch on the battery main switch and the ignition in the crane cab. Start the superstructure engine.
2. Activate the  setup mode in the automatic safe load indicator.

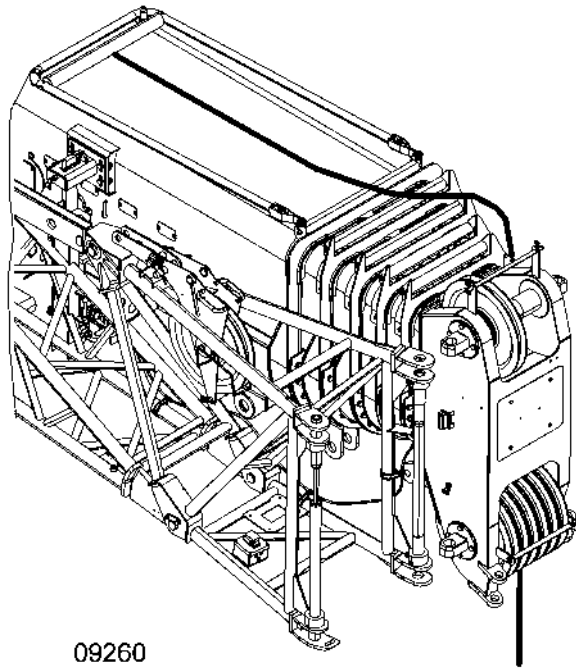

3. Wind/unwind the hoisting rope until the rope end projects above the boom head and stow it to the side. **NOTICE! Do not drag the hoisting rope on the ground.**

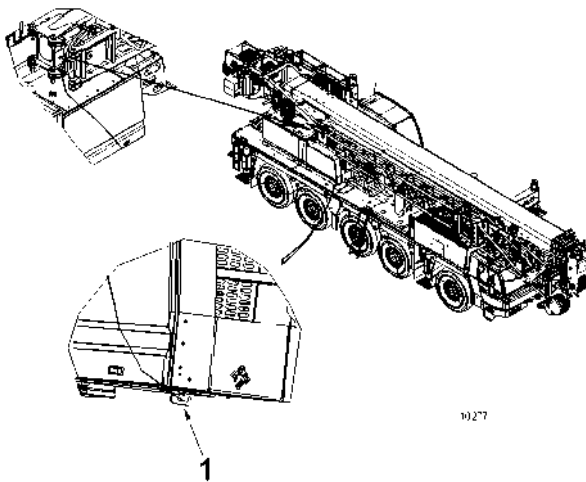

4. Fix the guide belt on the 6.0-m-stinger foot (19.7 ft). Secure the other end of the guide belt to the superstructure (1) to prevent the fly jib from pivoting out uncontrollably.



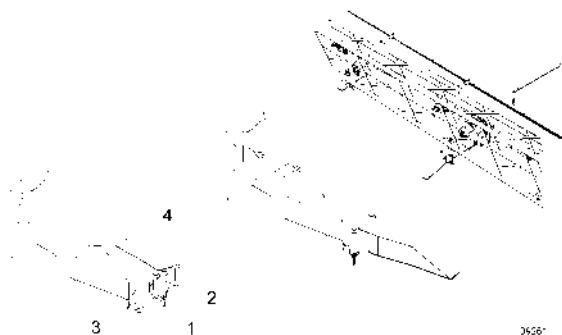

5. Fold out the transporting support. Remove the folding plug (1) and pull the bolt (2) downwards. Fold out the transporting support extension (4), insert the bolt (2) in the hole (3) from bottom and secure using the folding plug (1).
6. Connect the remote control.

#### Disconnecting the hydraulic and electrical connections

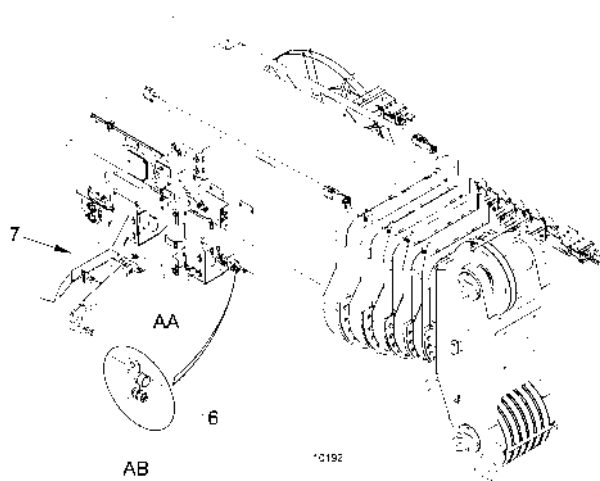

1. Disconnect the luffing jib hydraulic lines on the telescopic boom (6). Observe the following order when disconnecting:
  - ⇒ 1. Disconnect line (AA) for the luff up function.
  - ⇒ 2. Disconnect line (AB) for the luff down function.

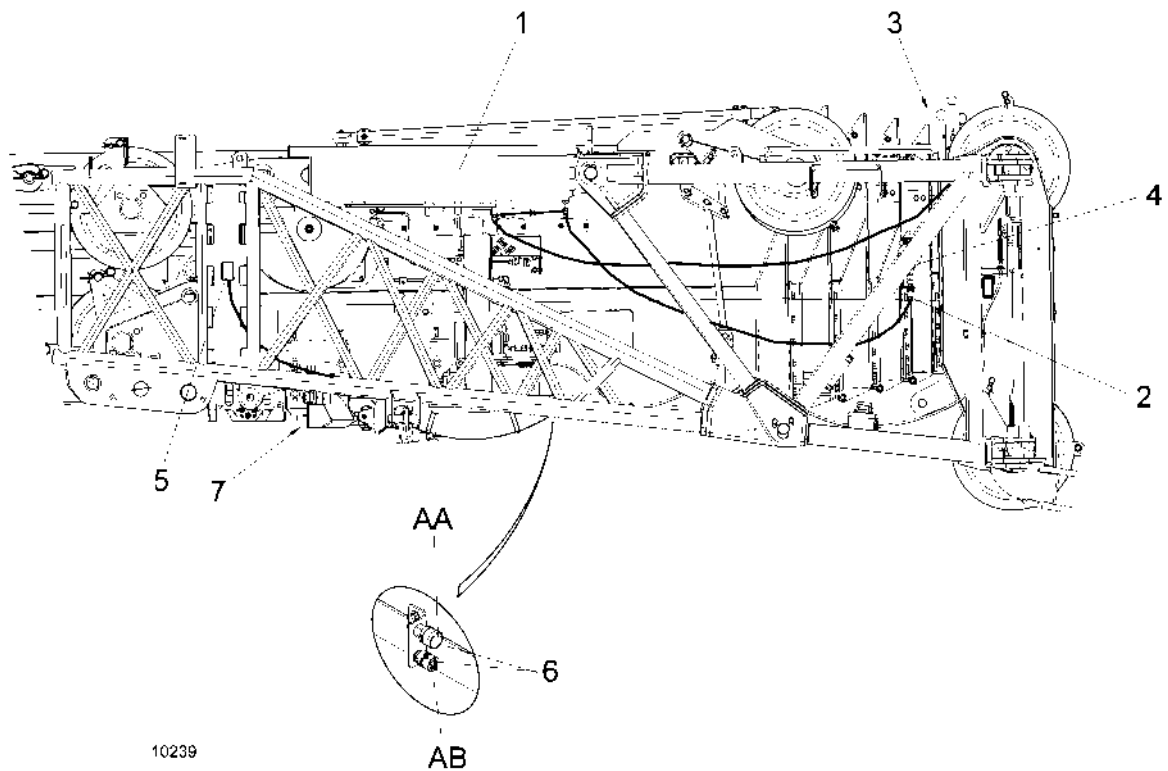

10239

2. Fit protective caps to the hydraulic connections (6). Place the luffing jib hydraulic lines in the clamp-fitted buffer (3) or fit to the expansion tank (4).
3. Disconnect the electrical connection from the telescopic boom (7), plug the line into the dummy connector housing (5) on the luffing jib.

## Pivoting the fly jib to the boom head

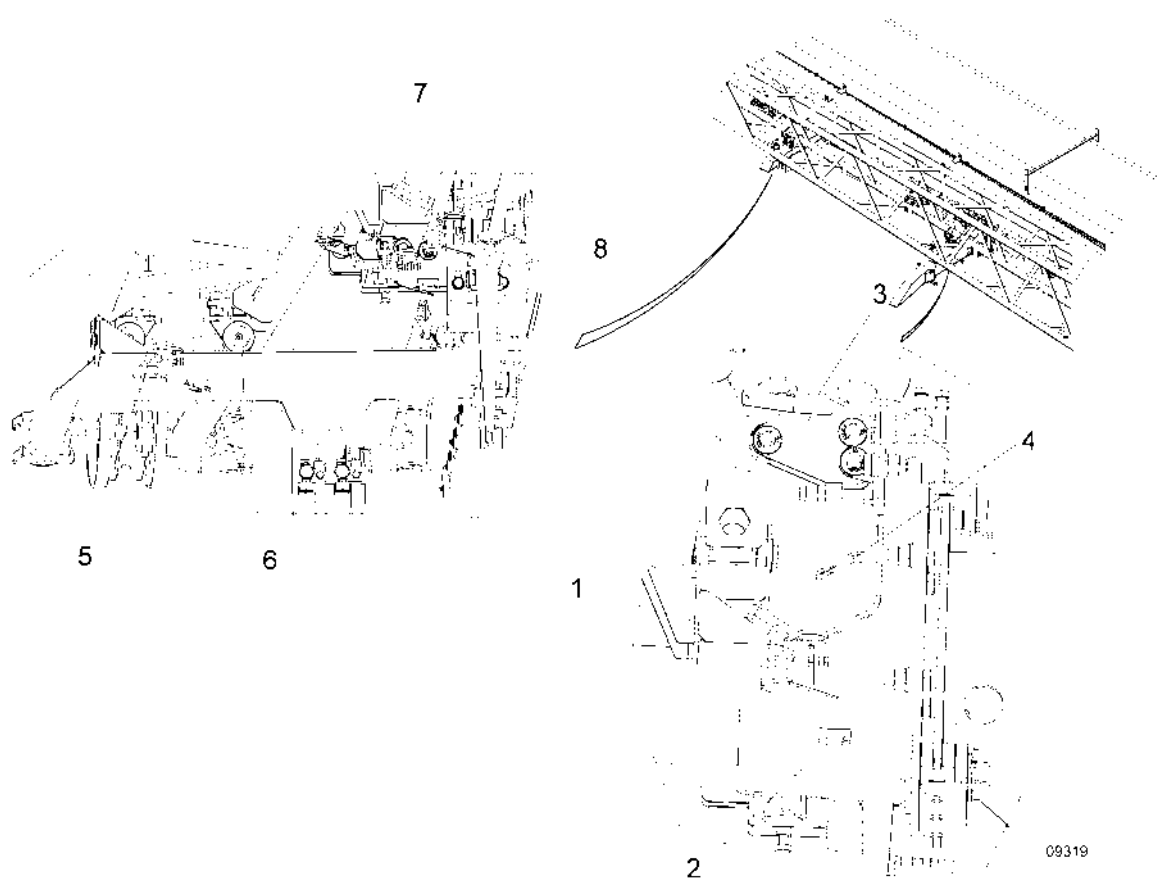

1. Loosen the pins (1) and (3) on the **middle** transporting support.  
Pull the spring clip and the locking pin, insert in the pin holder (2) or (4) and secure again using the spring clip.
2. Loosen the pins (5) and (7) on the **rear** transporting support.  
Pull the spring clip and the locking pin, insert in the pin holder (6) or (8) and secure again using the spring clip.
3. Extend the slewing cylinder using the remote control (right lever forwards) until the holes on the 3.8-m-fly jib (12.5 ft) are flush with the holes on the right-hand side of the boom head.

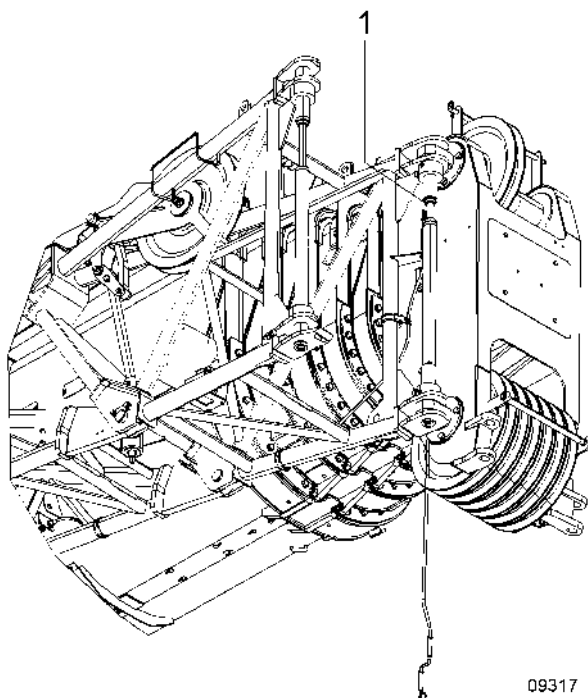

4. Insert the crank handle into the threaded bolt and turn until the third red marking (1) is completely visible. **⚠️ WARNING!** The upper and lower bolt elements must be retracted completely (up to the end stop) in the bearing brackets on the boom head. Since both bolt ends are not retracted completely, the stinger may fall.

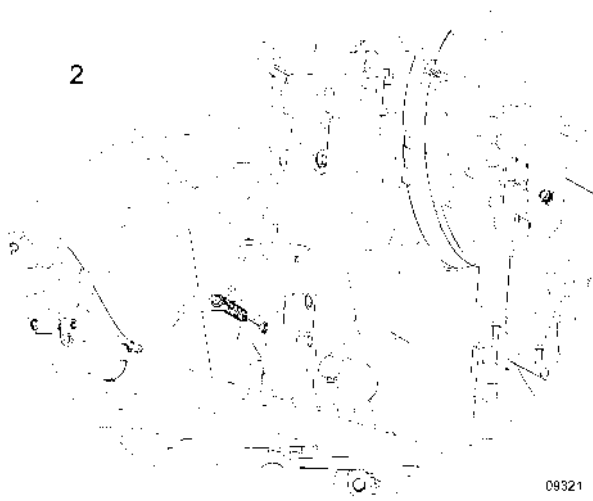

⇒ The safety flap (2) on the locking cylinder was turned using the rope arrangement.

5. Remove the crank handle again.

## Slewing the fly jib to the boom head

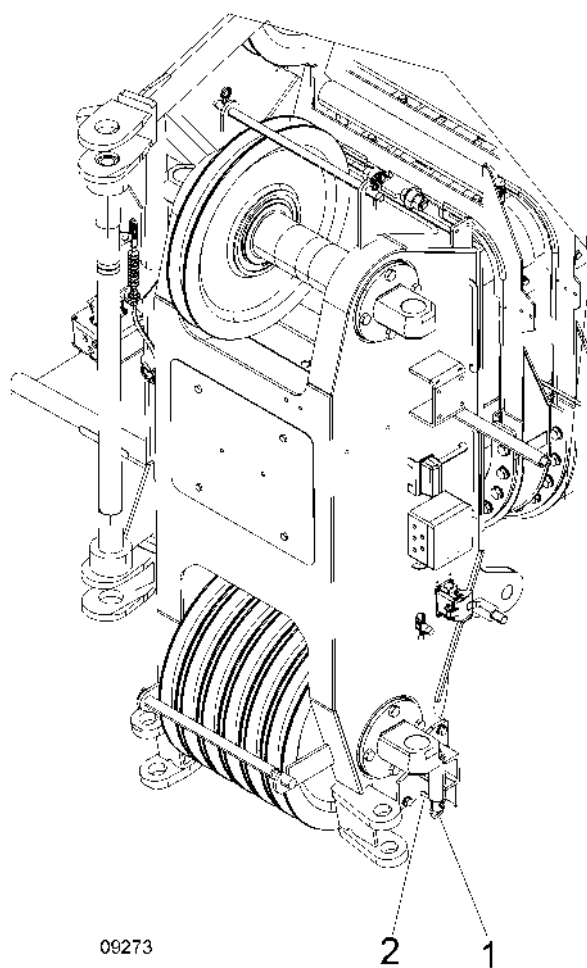

1. Release the lock on the left side of the boom head. For this, pull the ring (1) down and turn it by 90°. The pin (2) points towards the telescopic boom.
2. Loosen the hydraulic locking bolts between the telescopic boom and the stinger using the remote control (the left lever to the back).

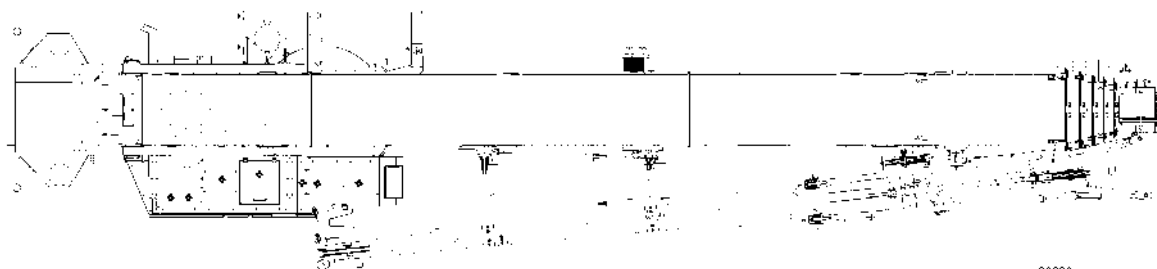

3. Extend the slewing cylinder completely using the remote control (the right lever to the front).  
 ⇒ The stinger rolls from the transporting supports.

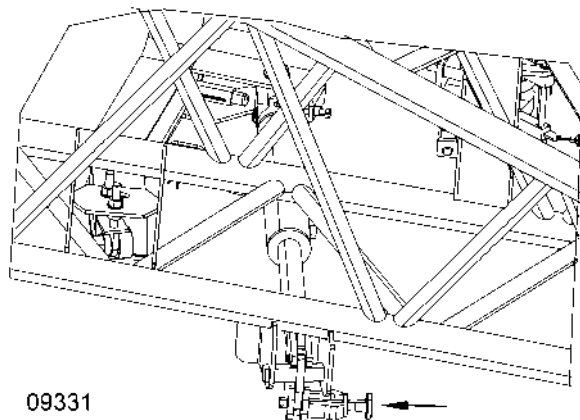

4. Pull the lock on the slewing cylinder.  
⇒ The stinger can be swiveled freely.
5. Loosen the guide belt of the mobile crane from below.
6. Swing open the stinger with the guide belt until it engages in the lock on the left side of the boom head.  
⇒ The holes on the 3.8-m-fly jib (12.5 ft) align with the holes on the left side of the boom head.

#### Connecting the hydraulic connections

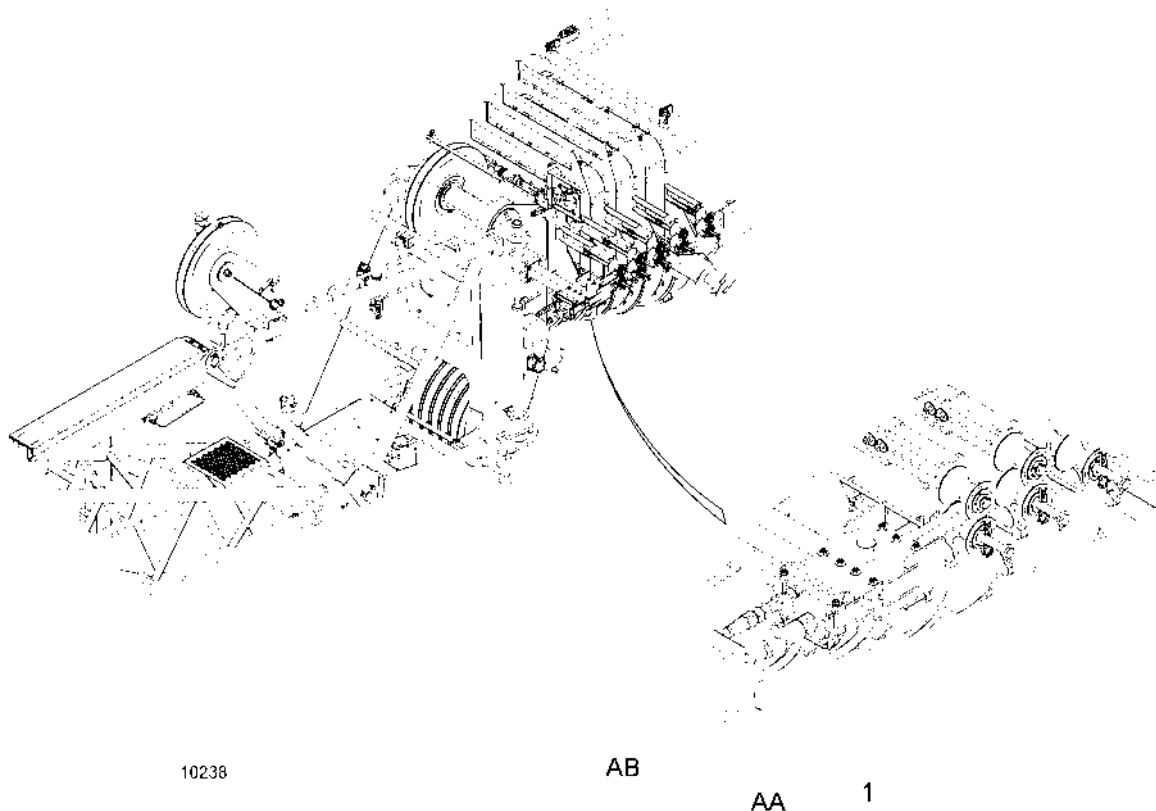

1. Establish a hydraulic connection by removing the hydraulic lines of the 3.8-m-fly jib (12.5 ft) from the clamp-fitted buffer or the expansion tank and connecting them to the connection (1) on the boom. Observe the following order for connecting to the telescopic boom:  
⇒ 1. Connect line (AB) for the luff down function.

- ⇒ 2. Connect line (AA) for the luff up function.

### Erecting and securing the sheave

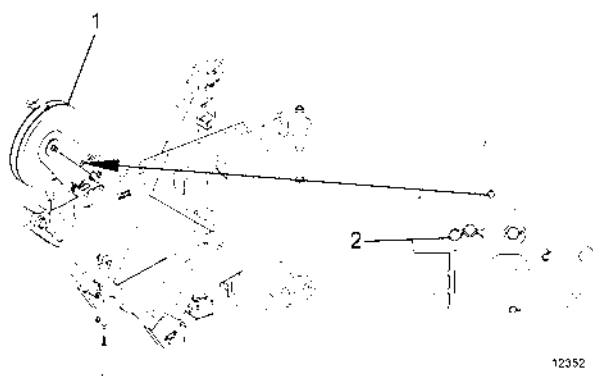

1. Wind the sheave of the 3.8-m-fly jib (12.5 ft) using the crank handle until further turning is not possible and the sheave is completely supported on the adapter. **⚠ CAUTION! If the sheave is not completely supported on the adapter, it may lead to uncontrolled lowering of the lifting load.**
2. Secure the supported sheave with a pin. Secure the pin using a spring clip.
3. Remove the crank handle again.

### Bolting the fly jib on the boom head

1. Unwind the hoisting rope until the rope end projects above the complete fly jib and stow it to the side. **NOTICE! Do not drag the hoisting rope on the ground.**

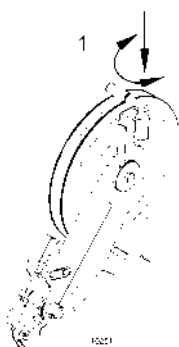

2. Place the hoisting rope on the sheave of the 3.8-m-stinger foot (12.5 ft). To do so, push the securing clamp (1) down and turn to the locked position (2). Place the hoisting rope on the sheave and turn back the securing clamp.

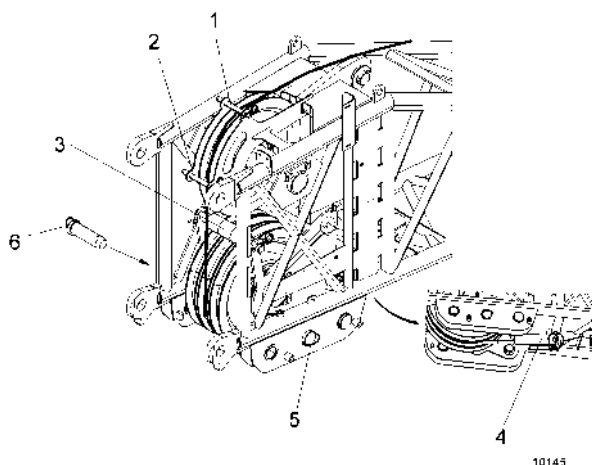

3. Owing to the dead weight of the stinger, the upper threaded bolt cannot be screwed in the upper hole of the bearing bracket as yet. To do this, lift the fly jib slightly using the hoisting gear, after the hoisting rope has been positioned and fixed to the rope fixing point of the fly jib.
4. Insert the crank handle into the threaded bolt and turn until the third red marking is completely visible.

**⚠WARNING!** The upper and lower bolt elements must be retracted completely (up to the end stop) in the bearing brackets on the boom head. Since both bolt ends are not retracted completely, the stinger may fall!

5. Remove the crank handle again.
6. Establish electrical connection for the anti-twoblock device and the aircraft warning lamp\*) between the telescopic boom and the stinger.

### Securing the transporting support

1. Retract the slewing cylinder using the remote control (the right lever to the back).



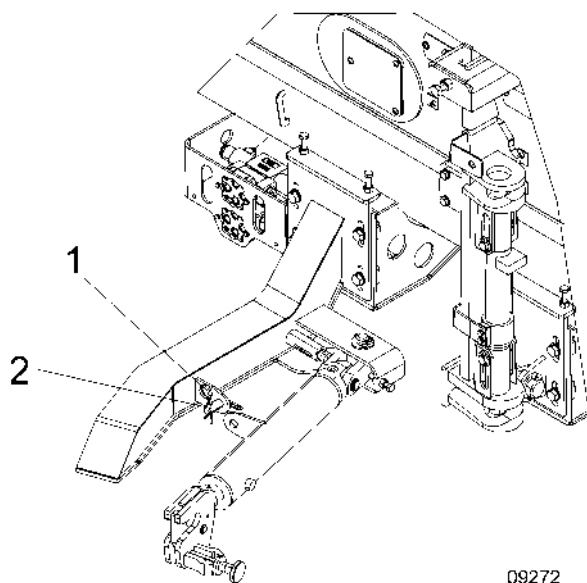

09272

2. Pin the slewing cylinder with the transporting support. Pull the spring clip (1) and bolt (2) for this. Push the slewing cylinder to the left until the hole on the transporting support aligns with the hole on the slewing cylinder. Loosen the bolt (2) and secure with the spring clip (1).
3. Switch off the engine and the ignition.
4. Detach the remote control.
5. Fold back the middle transporting support, pin and secure it.
6. Remove the guide belt from the fly jib.

### Bringing the boom tip into the working position

1. Fix the guide belt on the head of the boom end. Secure the other end of the belt to the 3.8-m-fly jib (12.5 ft) to prevent the boom tip from pivoting out uncontrollably.

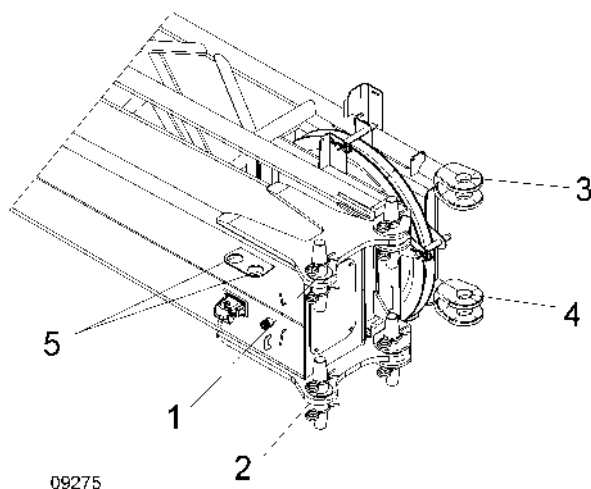

09275

2. Remove pins from holes (1) and (2). For this, pull the spring clip, pull out the pins, insert them into the pin compartment (5) and secure them.

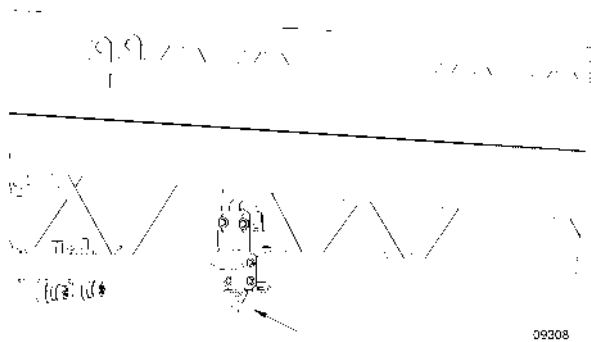

3. Loosen the pins between the 6.0-m-stinger foot (19.7 ft) and the boom end. For this, pull the retaining spring washer (using the crank handle) and turn it by 90°.
  - ⇒ The boom tip can be slewed freely.
4. Release the guide belt from the 3.8-m-fly jib foot (12.5 ft).

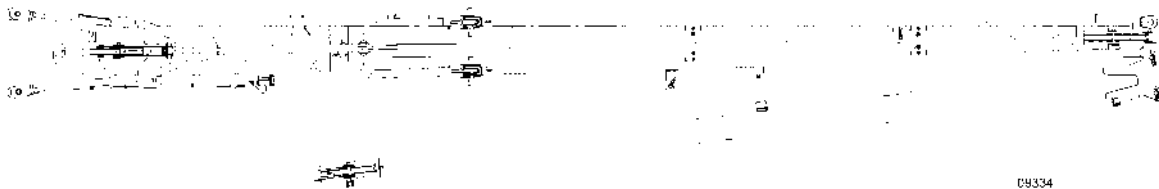

5. Pivot up the boom tip with the guide belt until the holes in the fly jib are flush with the holes on the fly jib foot.

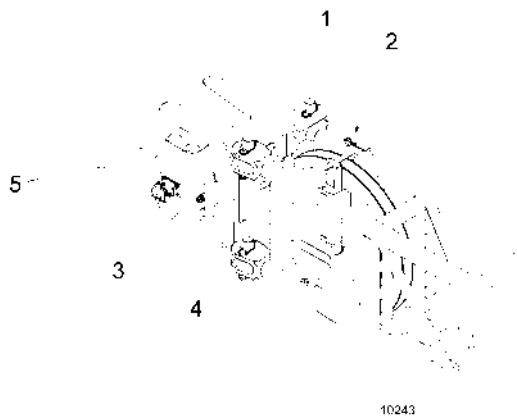

6. Take the pins out of the pin compartment (5), insert them into the holes (3) and (4) and secure them with spring clips.
7. Remove the guide belt from the boom tip.

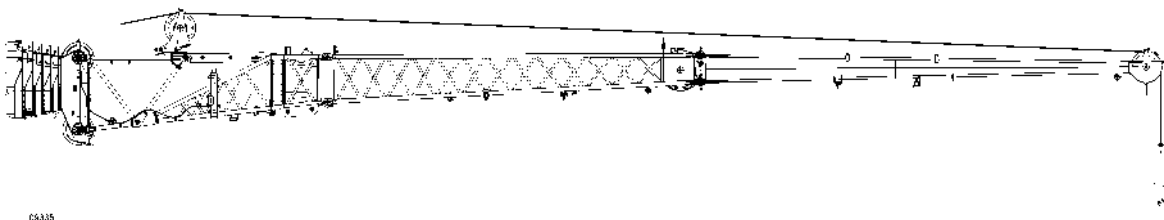

8. Place the hoisting rope on the sheave of the boom tip. To do this, pull the spring clip, remove the securing clamp and fit the hoisting rope. Secure the hoisting rope again with the securing clamp and spring clip.
9. Establish an electrical connection for the anti-twoblock device and the aircraft warning lamp\*) between the 6.0-m-fly jib foot (19.7 ft) and the boom tip.

### Finishing work

1. Mount the anti-twoblock device, *anemometer [page 160]* and *aircraft warning lamp [page 162]\**) on the head of the jib.
2. Guide the hoisting rope through the release weight of the anti-twoblock device.
3. Mount the *bottom block [page 403]*.
4. Enter the setup condition in the automatic safe load indicator.

### Working with the 10.2-m-stinger foot (33.5 ft)

The following section describes the structure of the 2-piece fly jib, i.e. the hydraulically angled 3.8-m-fly jib (12.5 ft), and the 6.0-m-fly jib foot (19.7 ft).



### Requirements

- The mobile crane is supported as prescribed.
- Counterweights required for the crane operation are attached.
- The slewing gear brake is engaged.
- All telescopes are retracted.
- The superstructure is slewed to the back or side.
- The telescopic boom is set horizontally ( $\pm 1^\circ$ ).

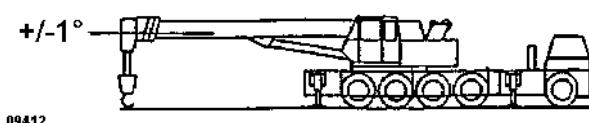
**⚠ WARNING!** In case of larger angles, there is a risk of accident and personal injuries.





- The fly jib (2-piece) is mounted on the telescopic boom in the transport position; the luffing jib hydraulic lines are connected to the mobile crane.
- The bottom block was placed on the ground and decoupled. The rope clamp and the release weight of the anti-twoblock device were removed from the hoisting rope. **NOTICE!** This point is not necessary for crane work using hoisting gear 1 via the boom head or hoisting gear 2 via the jib.
- The double ladder, crank handle and the remote control for the slewing cylinder are ready.

	 <b>WARNING</b>
	<p><b>Risk of skidding and accident!</b></p> <p>When climbing and stepping on ladders and access ladders, take utmost care especially in case of humid weather.</p> <ol style="list-style-type: none"> <li>1. Always keep the ladders and access ladders clean.</li> <li>2. Remove dirt and other greasy substances immediately and thoroughly.</li> <li>3. Always hold the ladder beams or handles while climbing up or down.</li> <li>4. Wear non-slip shoes and keep them clean.</li> <li>5. Ensure that the ladders are safe.</li> </ol>

- The pressure gauge on the hydraulic cylinder shows more than 100 bar (1450.4 psi).

**Checking the hydraulic oil pressure in the hydraulic cylinder of the fly jib**

	 <b>WARNING</b>
	<p><b>Insufficient pressure in the hydraulic cylinder!</b></p> <p>If the pressure in the hydraulic cylinder is too low, the jib may fold down uncontrollably when it is being fitted to the boom or pivoted out.</p> <ol style="list-style-type: none"> <li>1. Every time the jib is to be fitted or pivoted out, you must first check that the pressure in the hydraulic cylinder is more than 100 bar (1,450.4 PSI).</li> <li>2. If the pressure shown is less than 100 bar (1,450.4 PSI), the jib must not be fitted or pivoted out.</li> </ol>

There is a pressure gauge under the hydraulic cylinder (1) for the hydraulically angled jib.

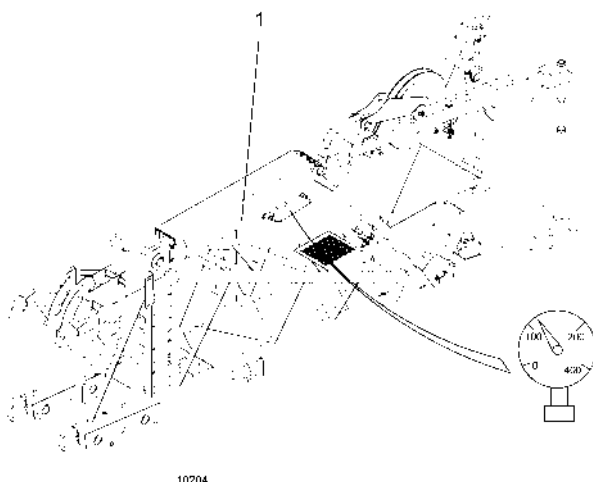

If the pressure gauge shows a pressure of less than 100 bar (1450.4 psi), the pressure must be increased.

To build up the pressure in the hydraulic cylinder, proceed as follows:

1. Switch on the battery main switch and the ignition in the crane cab. Start the superstructure engine.
2. Operate the "Activate jib luffing" rocker switch.
3. Carefully operate the crane control lever in the "Raise luffing jib" function until the pressure gauge shows a pressure of more than 100 bar (1450.4 psi).

The "Jib, luffing cylinder not retracted" warning lamp must not light up as you do this.

- The "Jib luffing cylinder not retracted" warning lamp does not light up.

	<p><b>! WARNING</b></p>
<p><b>"Jib luffing cylinder not retracted" warning lamp lights up!</b></p> <p>If the "Jib luffing cylinder not retracted" warning lamp lights up, the luffing jib cannot be correctly fitted to the boom. This may cause the jib to drop and people may be injured.</p> <ol style="list-style-type: none"> <li>1. Before fitting the jib to the boom, check the "Jib luffing cylinder not retracted" warning lamp.</li> <li>2. Do not fit the luffing jib if the warning lamp is lit.</li> </ol>	

To check the "Jib luffing cylinder not retracted" warning lamp, proceed as follows:

1. Start the superstructure engine.
2. Operate the "Activate jib luffing" rocker switch.
3. If the "Jib, luffing cylinder not retracted" warning lamp does **not** light up, the jib can be attached and pivoted out.
4. If the "Jib, luffing cylinder not retracted" warning lamp lights up, carefully operate the "Raise luffing jib" function on the crane control lever until the warning lamp goes out.



Further prerequisite:

- The hydraulic connections on the hose drum are in the working position.

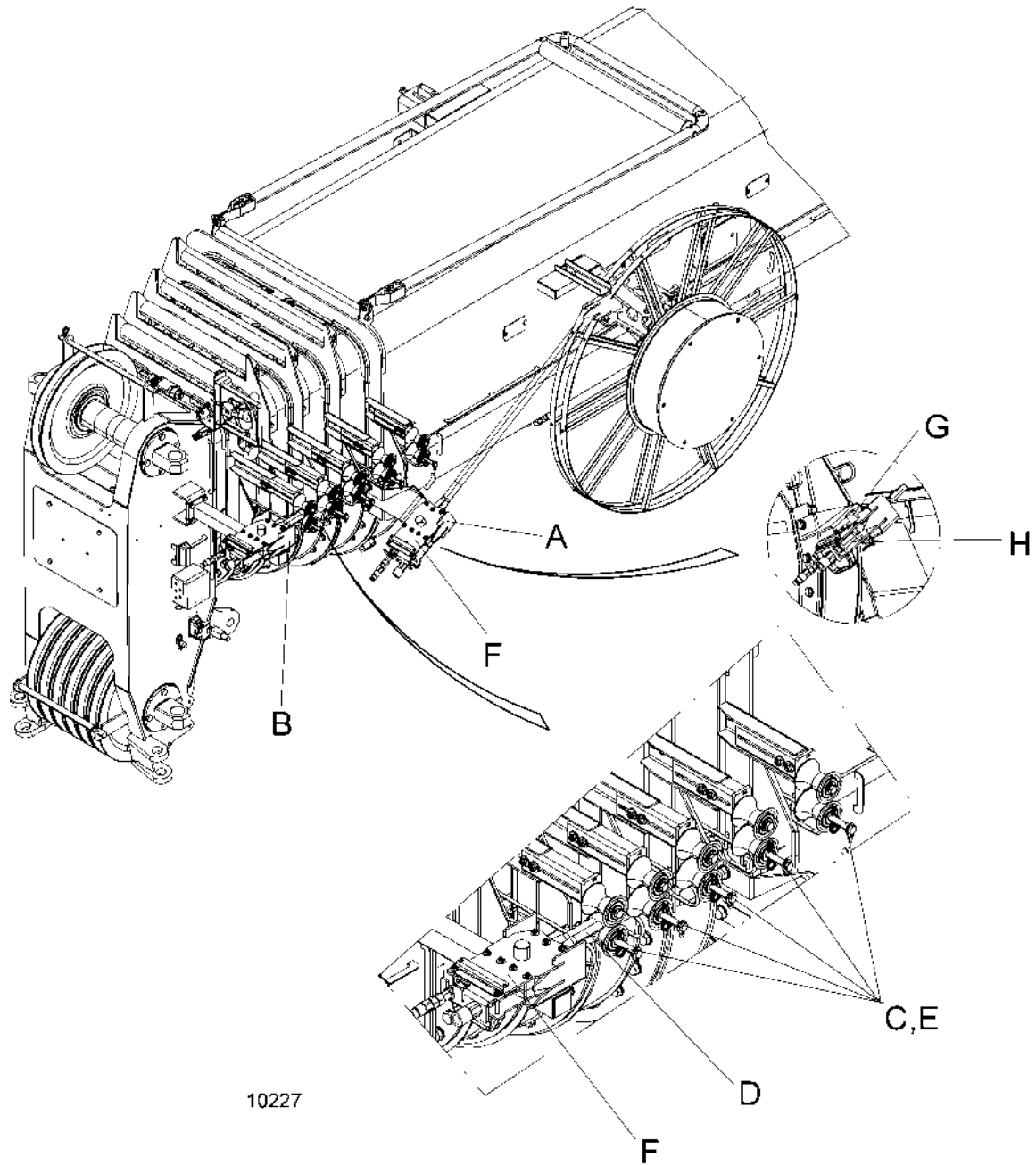
The procedure for switching the hydraulic connections from the transport position to the working position is described below.



A	Transport position	E	Guide pulleys
B	Working position	F	Console with hydraulic connector
C	Spring clip	G	Pin
D	Hydraulic lines	H	Spring clip

	 <b>WARNING</b>
	<p><b>Risk of accident from rebounding hydraulic lines!</b></p> <p>The hose drum is under spring tension. People could be injured if the console with hydraulic connector (F) is released.</p> <ol style="list-style-type: none"> <li>1. Use the double ladder.</li> <li>2. Make sure you have a firm footing when moving the console with hydraulic connector (F).</li> <li>3. Make sure you have a firm hold on the console with hydraulic connector (F).</li> </ol>

1. Release the spring clip (C) and move the guide pulleys (E).
2. Take the console with hydraulic connector (F) out of the transport position (A). To do this, pull the spring clip (H) and pin (G).
3. Insert the console with hydraulic connector (F) into the working position (B) and secure with the pin (G) and spring clip (H).
4. Thread the hydraulic lines (D) into the guide. Slide the guide pulleys (E) back and secure with the spring clip (C).

**The hydraulic connections on the hose drum are now in the working position.**

The hose drum is returned to the transport position in the reverse order.

### Bringing the fly jib into the working position

#### Preparations

1. Switch on the battery main switch and the ignition in the crane cab. Start the superstructure engine.
2. Activate the  setup mode in the automatic safe load indicator.

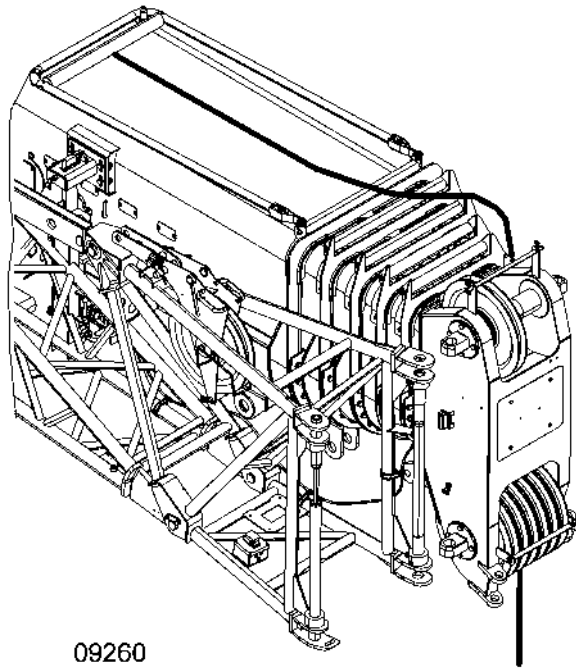

3. Wind/unwind the hoisting rope until the rope end projects above the boom head and stow it to the side. **NOTICE! Do not drag the hoisting rope on the ground.**

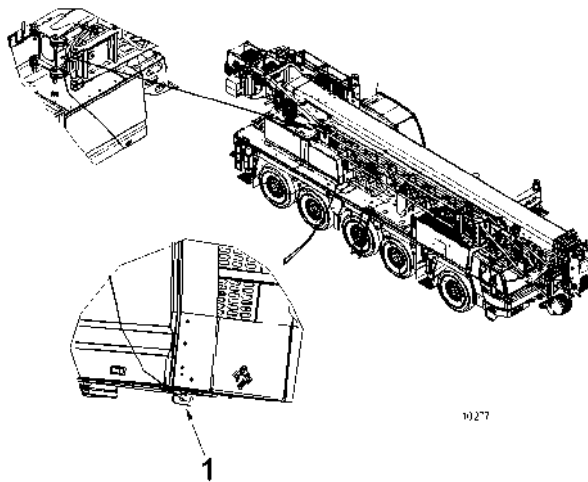

4. Fix the guide belt on the 6.0-m-stinger foot (19.7 ft). Secure the other end of the guide belt to the superstructure (1) to prevent the fly jib from pivoting out uncontrollably.



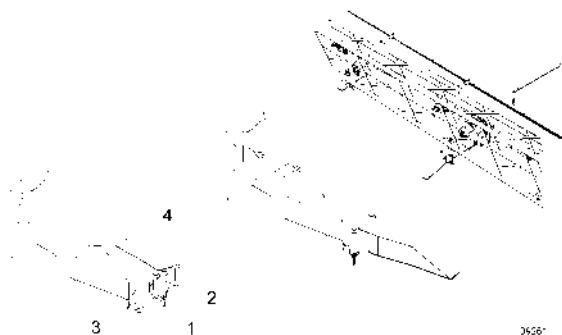

5. Fold out the transporting support. Remove the folding plug (1) and pull the bolt (2) downwards. Fold out the transporting support extension (4), insert the bolt (2) in the hole (3) from bottom and secure using the folding plug (1).
6. Connect the remote control.

#### Disconnecting the hydraulic and electrical connections

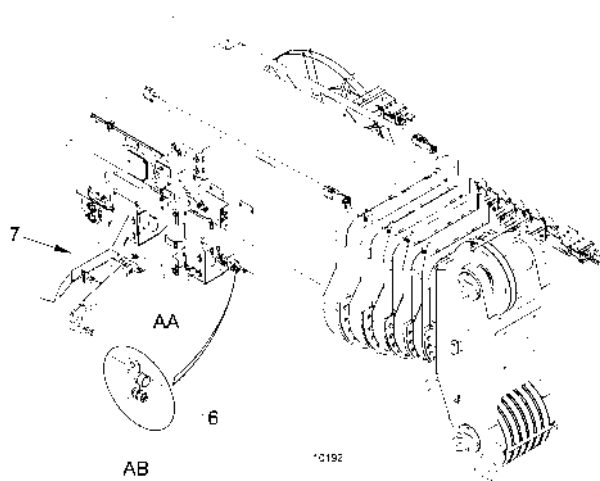

1. Disconnect the luffing jib hydraulic lines on the telescopic boom (6). Observe the following order when disconnecting:
  - ⇒ 1. Disconnect line (AA) for the luff up function.
  - ⇒ 2. Disconnect line (AB) for the luff down function.

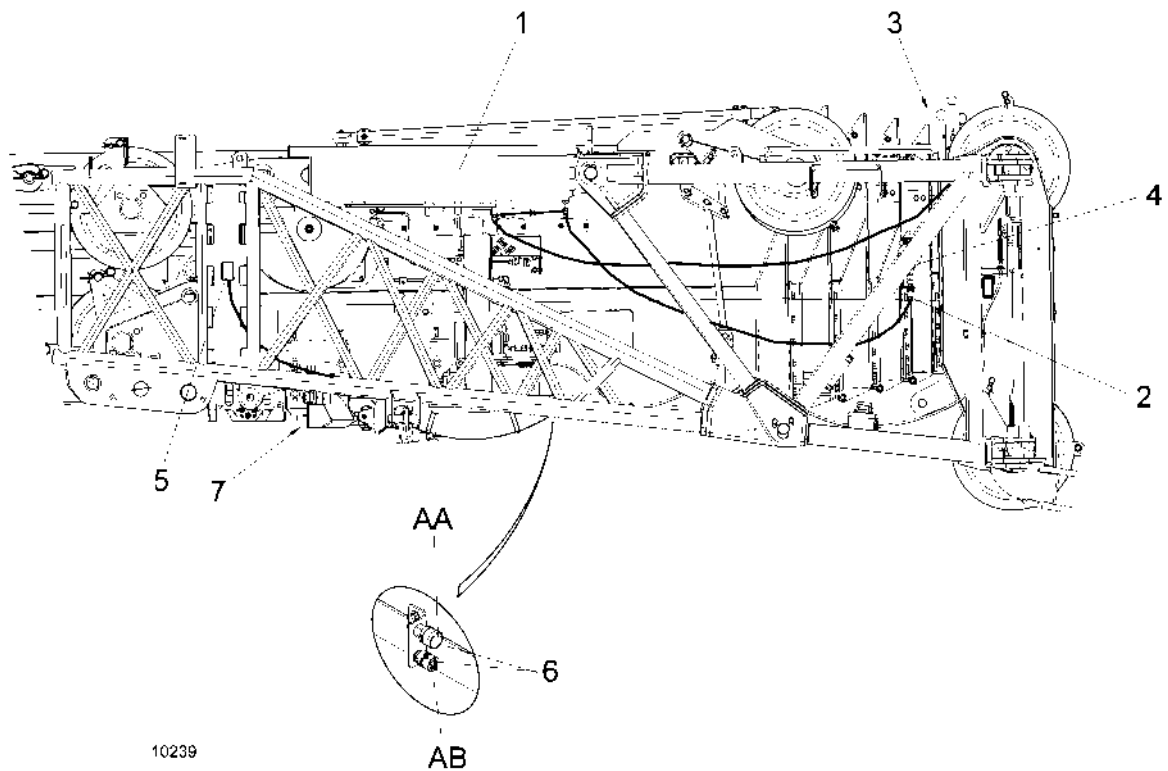

2. Fit protective caps to the hydraulic connections (6). Place the luffing jib hydraulic lines in the clamp-fitted buffer (3) or fit to the expansion tank (4).
3. Disconnect the electrical connection from the telescopic boom (7), plug the line into the dummy connector housing (5) on the luffing jib.

### Disconnecting the boom tip from the 6.0-m-stinger foot (19.7 ft)

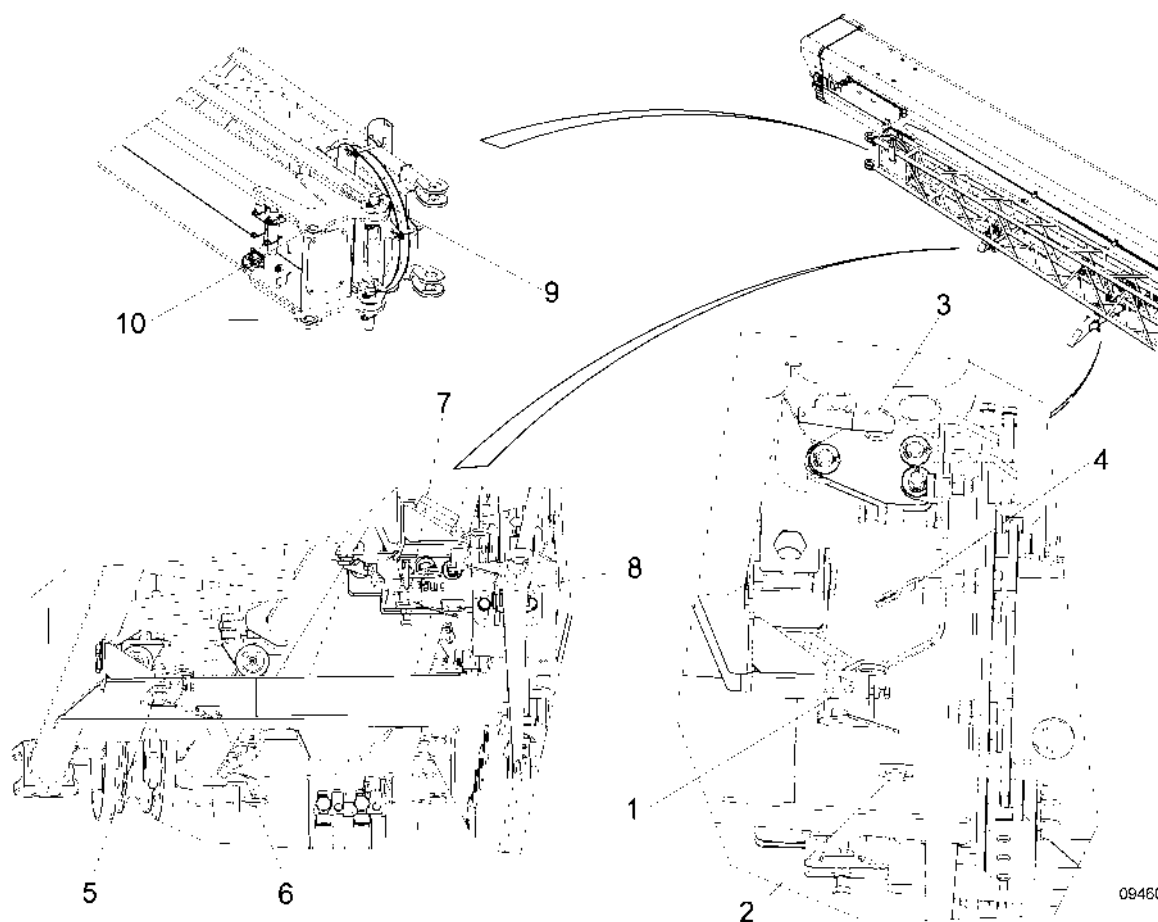

1. Release the pin (9) between the 6.0-m-fly jib foot (19.7 ft) and the boom tip.  
Pull the spring clip and the locking pin, insert into the hole (10) and secure again using the spring clip.
2. Loosen the pin (1) on the **middle** transporting support.  
Pull the spring clip and the locking pin, insert in the pin holder (2) and secure again using the spring clip.
3. Loosen the pin (5) on the **rear** transporting support.  
Pull the spring clip and the locking pin, insert in the pin holder (6) and secure again using the spring clip.

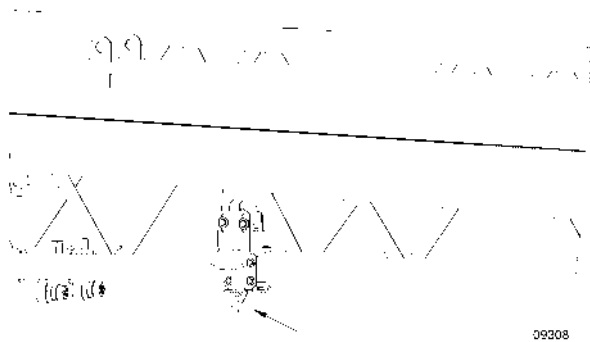

4. Loosen the pins between the 6.0-m-stinger foot (19.7 ft) and the boom tip. For this, pull the retaining spring washer (using the crank handle) and turn it by 90°.

#### Pivoting the fly jib to the boom head

1. Extend the slewing cylinder using the remote control (right lever forwards) until the holes on the 3.8-m-fly jib (12.5 ft) are flush with the holes on the right-hand side of the boom head.

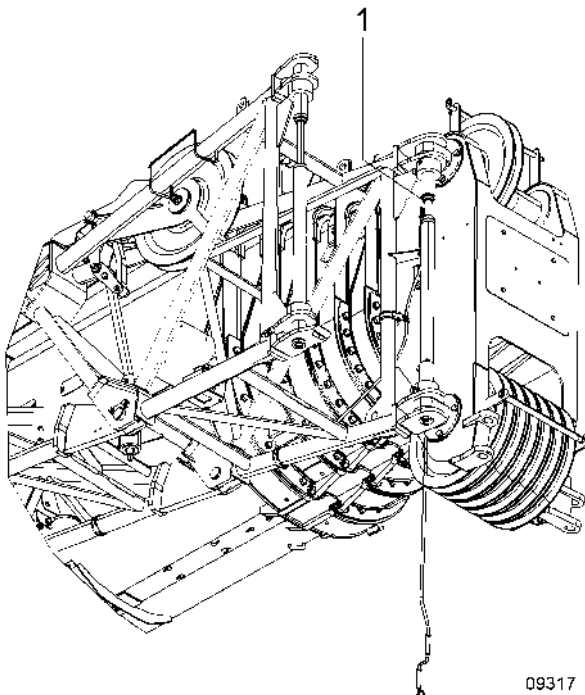

2. Insert the crank handle into the threaded bolt and turn until the third red marking (1) is completely visible. **⚠️WARNING!** The upper and lower bolt elements must be retracted completely (up to the end stop) in the bearing brackets on the boom head. Since both bolt ends are not retracted completely, the stinger may fall.

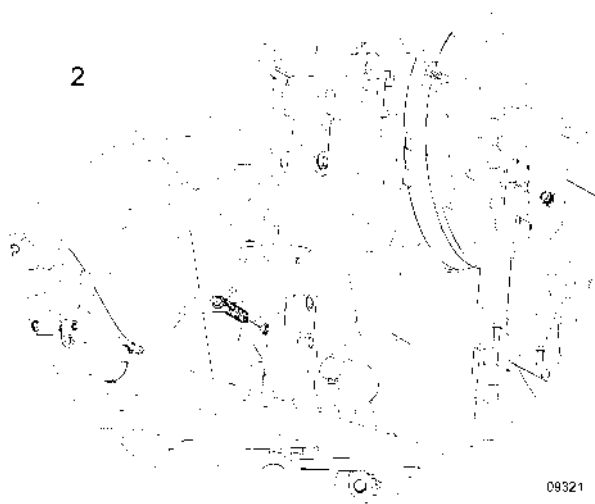

⇒ The safety flap (2) on the locking cylinder was turned using the rope arrangement.

3. Remove the crank handle again.

### Slewing the fly jib to the boom head

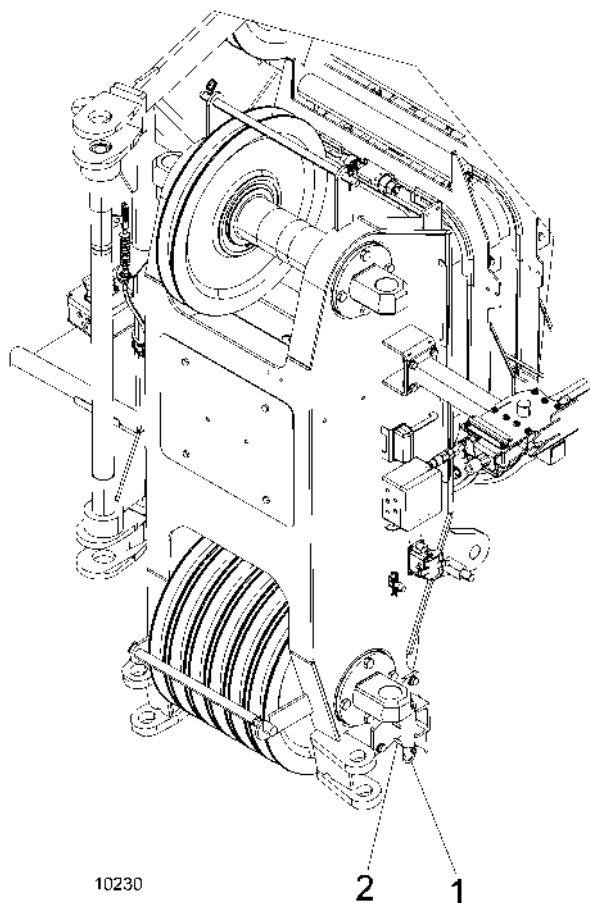

1. Release the lock on the left side of the boom head. For this, pull the ring (1) down and turn it by 90°. The pin (2) points towards the telescopic boom.

2. Loosen the hydraulic locking bolts between the telescopic boom and the stinger using the remote control (the left lever to the back).

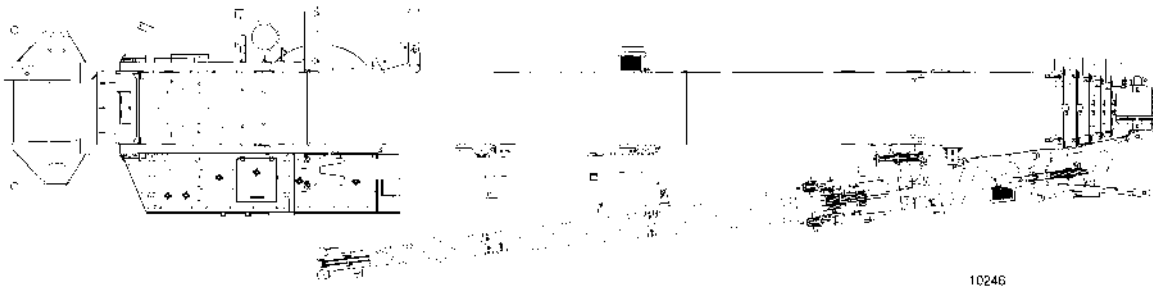

3. Extend the slewing cylinder completely using the remote control (the right lever to the front).  
⇒ The stinger rolls from the transporting supports.

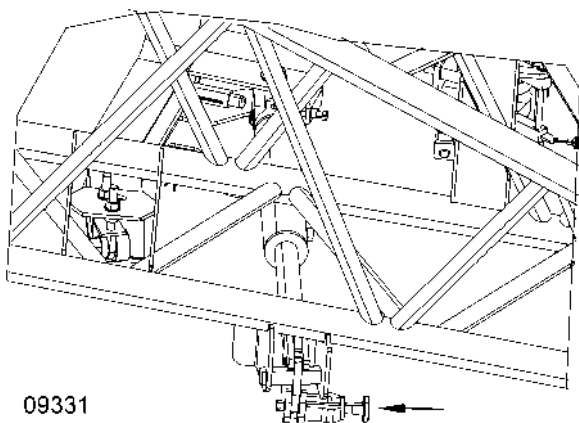

4. Pull the lock on the slewing cylinder.  
⇒ The stinger can be swiveled freely.
5. Loosen the guide belt of the mobile crane from below.
6. Swing open the stinger with the guide belt until it engages in the lock on the left side of the boom head.  
⇒ The holes on the 3.8-m-fly jib (12.5 ft) align with the holes on the left side of the boom head.

## Connecting the hydraulic connections

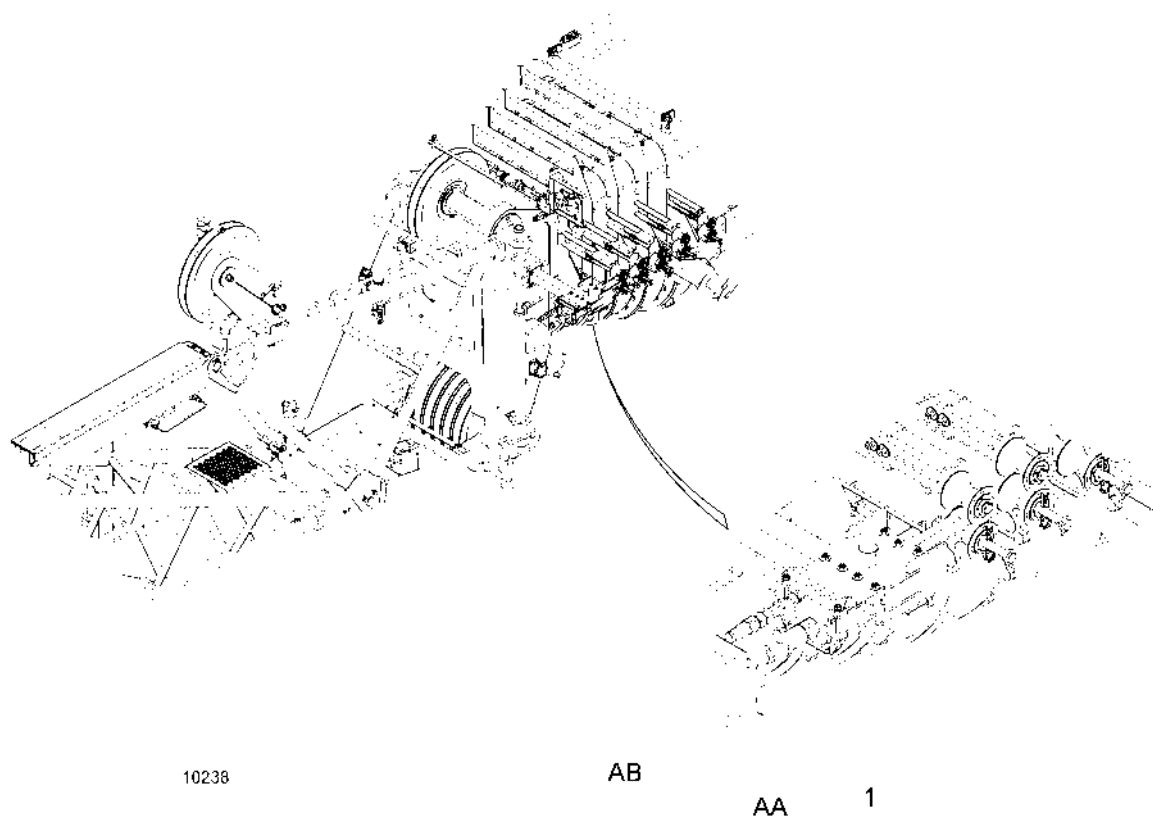

1. Establish a hydraulic connection by removing the hydraulic lines of the 3.8-m-fly jib (12.5 ft) from the clamp-fitted buffer or the expansion tank and connecting them to the connection (1) on the boom. Observe the following order for connecting to the telescopic boom:
  - ⇒ 1. Connect line (AB) for the luff down function.
  - ⇒ 2. Connect line (AA) for the luff up function.

### Erecting and securing the sheave

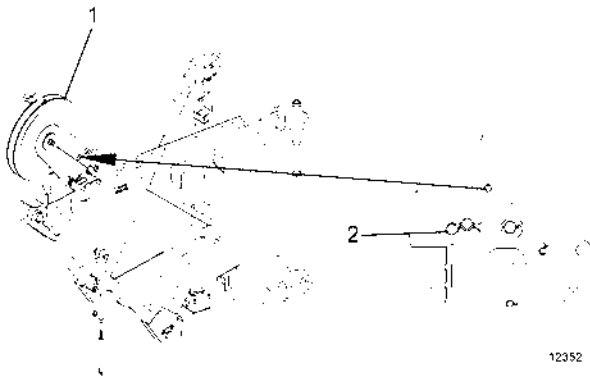

1. Wind the sheave of the 3.8-m-fly jib (12.5 ft) using the crank handle until further turning is not possible and the sheave is completely supported on the adapter. **⚠ CAUTION! If the sheave is not completely supported on the adapter, it may lead to uncontrolled lowering of the lifting load.**
2. Secure the supported sheave with a pin. Secure the pin using a spring clip.
3. Remove the crank handle again.

### Bolting the fly jib on the boom head

1. Unwind the hoisting rope until the rope end projects above the complete fly jib and stow it to the side. **NOTICE! Do not drag the hoisting rope on the ground.**



2. Place the hoisting rope on the sheave of the 3.8-m-stinger foot (12.5 ft). To do so, push the securing clamp (1) down and turn to the locked position (2). Place the hoisting rope on the sheave and turn back the securing clamp.



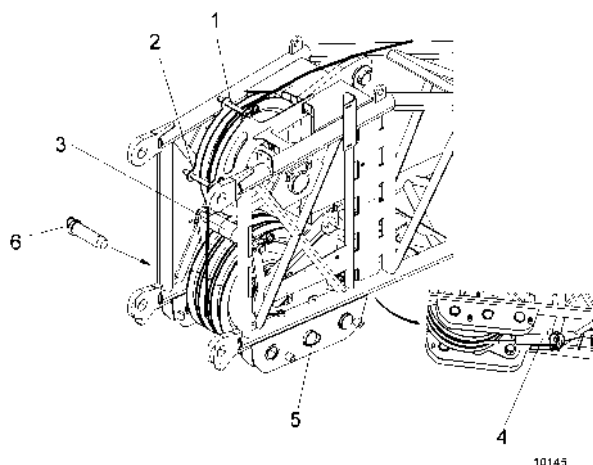

3. Owing to the dead weight of the stinger, the upper threaded bolt cannot be screwed in the upper hole of the bearing bracket as yet. To do this, lift the fly jib slightly using the hoisting gear, after the hoisting rope has been positioned and fixed to the rope fixing point of the fly jib.
4. Insert the crank handle into the threaded bolt and turn until the third red marking is completely visible.

**⚠ WARNING!** The upper and lower bolt elements must be retracted completely (up to the end stop) in the bearing brackets on the boom head. Since both bolt ends are not retracted completely, the stinger may fall!

5. Remove the crank handle again.
6. Establish electrical connection for the anti-two-block device and the aircraft warning lamp\*) between the telescopic boom and the stinger.

### Securing the transporting support

1. Retract the slewing cylinder using the remote control (the right lever to the back).

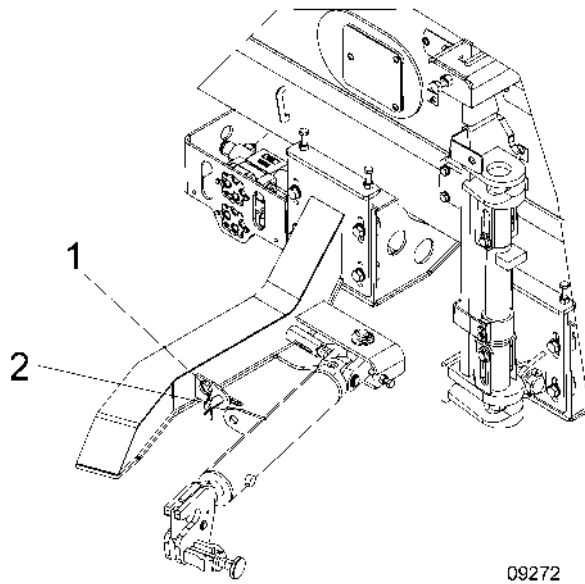

- 
2. Pin the slewing cylinder with the transporting support. Pull the spring clip (1) and bolt (2) for this. Push the slewing cylinder to the left until the hole on the transporting support aligns with the hole on the slewing cylinder. Loosen the bolt (2) and secure with the spring clip (1).
3. Switch off the engine and the ignition.
4. Detach the remote control.
5. Fold back the transporting support, pin and secure it.
6. Remove the guide belt from the 6.0-m-stinger foot (19.7 ft).
7. Place the hoisting rope on the head of the 6.0-m-stinger foot (19.7 ft) and secure it using securing clamps.

### Finishing work

1. Mount the anti-twoblock device, *anemometer* [page 160] and *aircraft warning lamp* [page 162<sup>\*</sup>) on the head of the jib.
2. Guide the hoisting rope through the release weight of the anti-twoblock device.
3. Mount the *bottom block* [page 403].
4. Enter the setup condition in the automatic safe load indicator.

### Working with the 3.8-m-stinger foot (12.5 ft)

The following section describes the structure of the 3.8-m-fly jib (12.5 ft).

### Requirements

- The mobile crane is supported as prescribed.
- Counterweights required for the crane operation are attached.
- The slewing gear brake is engaged.

- All telescopes are retracted.
- The superstructure is slewed to the back or side.
- The telescopic boom is set horizontally ( $\pm 1^\circ$ ).

**⚠ WARNING!** In case of larger angles, there is a risk of accident and personal injuries.

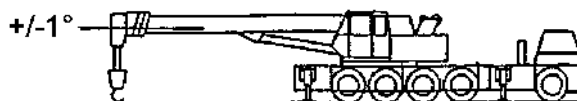

09412

- The stinger (3-piece) is mounted at the transport position on the telescopic boom.
- The heavy-lift sheave is mounted on the 3.8-m-stinger foot (12.5 ft).
- The bottom block was placed on the ground and decoupled. The rope clamp and the release weight of the anti-twoblock device were removed from the hoisting rope.
- The double ladder, crank handle and the remote control for the slewing cylinder are ready.

	<b>⚠ WARNING</b>
	<p><b>Risk of skidding and accident!</b></p> <p>When climbing and stepping on ladders and access ladders, take utmost care especially in case of humid weather.</p> <ol style="list-style-type: none"> <li>1. Always keep the ladders and access ladders clean.</li> <li>2. Remove dirt and other greasy substances immediately and thoroughly.</li> <li>3. Always hold the ladder beams or handles while climbing up or down.</li> <li>4. Wear non-slip shoes and keep them clean.</li> <li>5. Ensure that the ladders are safe.</li> </ol>

- The pressure gauge on the hydraulic cylinder shows more than 100 bar (1450.4 psi).

#### Checking the hydraulic oil pressure in the hydraulic cylinder of the fly jib

	<b>⚠ WARNING</b>
	<p><b>Insufficient pressure in the hydraulic cylinder!</b></p> <p>If the pressure in the hydraulic cylinder is too low, the jib may fold down uncontrollably when it is being fitted to the boom or pivoted out.</p> <ol style="list-style-type: none"> <li>1. Every time the jib is to be fitted or pivoted out, you must first check that the pressure in the hydraulic cylinder is more than 100 bar (1,450.4 PSI).</li> <li>2. If the pressure shown is less than 100 bar (1,450.4 PSI), the jib must not be fitted or pivoted out.</li> </ol>

There is a pressure gauge under the hydraulic cylinder (1) for the hydraulically angled jib.



If the pressure gauge shows a pressure of less than 100 bar (1450.4 psi), the pressure must be increased.

To build up the pressure in the hydraulic cylinder, proceed as follows:

1. Switch on the battery main switch and the ignition in the crane cab. Start the superstructure engine.
2. Operate the "Activate jib luffing" rocker switch.
3. Carefully operate the crane control lever in the "Raise luffing jib" function until the pressure gauge shows a pressure of more than 100 bar (1450.4 psi).

The "Jib, luffing cylinder not retracted" warning lamp must not light up as you do this.

- The "Jib luffing cylinder not retracted" warning lamp does not light up.

	<p><b>! WARNING</b></p>
	<p><b>"Jib luffing cylinder not retracted" warning lamp lights up!</b></p> <p>If the "Jib luffing cylinder not retracted" warning lamp lights up, the luffing jib cannot be correctly fitted to the boom. This may cause the jib to drop and people may be injured.</p> <ol style="list-style-type: none"> <li>1. Before fitting the jib to the boom, check the "Jib luffing cylinder not retracted" warning lamp.</li> <li>2. Do not fit the luffing jib if the warning lamp is lit.</li> </ol>

To check the "Jib luffing cylinder not retracted" warning lamp, proceed as follows:

1. Start the superstructure engine.
2. Operate the "Activate jib luffing" rocker switch.
3. If the "Jib, luffing cylinder not retracted" warning lamp does **not** light up, the jib can be attached and pivoted out.
4. If the "Jib, luffing cylinder not retracted" warning lamp lights up, carefully operate the "Raise luffing jib" function on the crane control lever until the warning lamp goes out.



Further prerequisite:

- The hydraulic connections on the hose drum are in the working position.

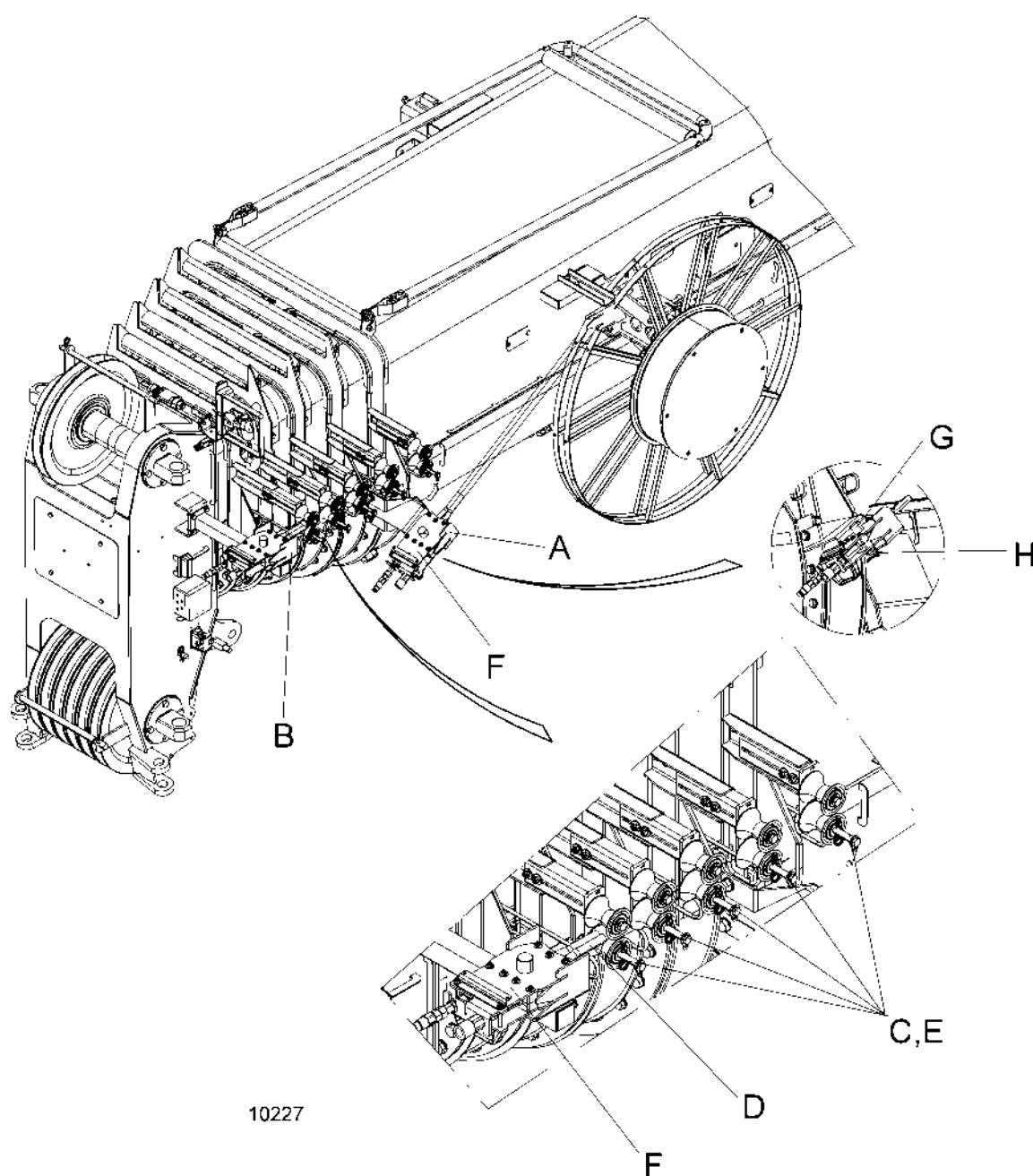
## Bringing the hydraulic connections into the working position



A	Transport position	E	Guide pulleys
B	Working position	F	Console with hydraulic connector
C	Spring clip	G	Pin
D	Hydraulic lines	H	Spring clip

	 <b>WARNING</b>
	<p><b>Risk of accident from rebounding hydraulic lines!</b></p> <p>The hose drum is under spring tension. People could be injured if the console with hydraulic connector (F) is released.</p> <ol style="list-style-type: none"> <li>1. Use the double ladder.</li> <li>2. Make sure you have a firm footing when moving the console with hydraulic connector (F).</li> <li>3. Make sure you have a firm hold on the console with hydraulic connector (F).</li> </ol>

1. Release the spring clip (C) and move the guide pulleys (E).
2. Take the console with hydraulic connector (F) out of the transport position (A). To do this, pull the spring clip (H) and pin (G).
3. Insert the console with hydraulic connector (F) into the working position (B) and secure with the pin (G) and spring clip (H).
4. Thread the hydraulic lines (D) into the guide. Slide the guide pulleys (E) back and secure with the spring clip (C).

**The hydraulic connections on the hose drum are now in the working position.**

The hose drum is returned to the transport position in the reverse order.

#### Separating the 3.8-m-stinger foot (12.5 ft) from the 6.0-m-stinger foot (19.7 ft)

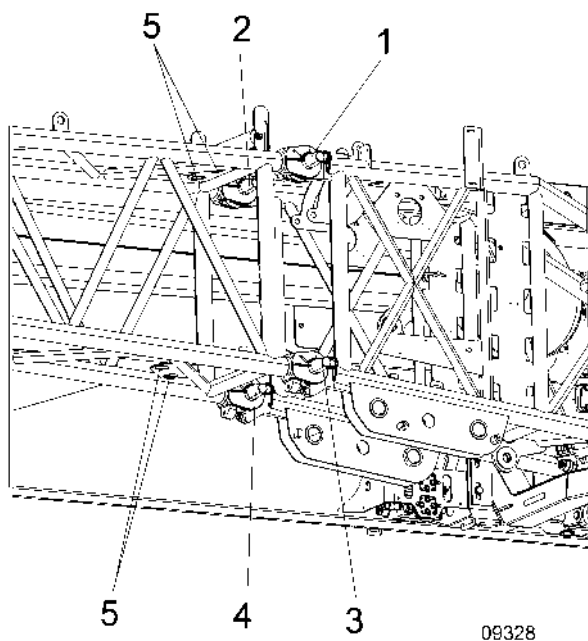

1. Remove the pins from holes (1), (2), (3) and (4), insert them into pin compartments (5) and secure them.

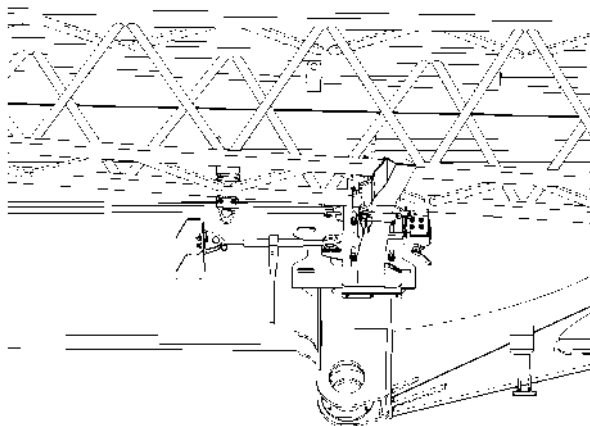

09327

2. Move the 6.0-m-stinger foot (19.7 ft) up to the left end stop using the ratchet chain clamp. The 3.8-m-stinger (12.5 ft) is connected with the 6.0-m-stinger foot (19.7 ft) in the logical reverse order.

### Bringing the fly jib into the working position

#### Preparations

1. Switch on the battery main switch and the ignition in the crane cab. Start the superstructure engine.
2. Activate the  setup mode in the automatic safe load indicator.

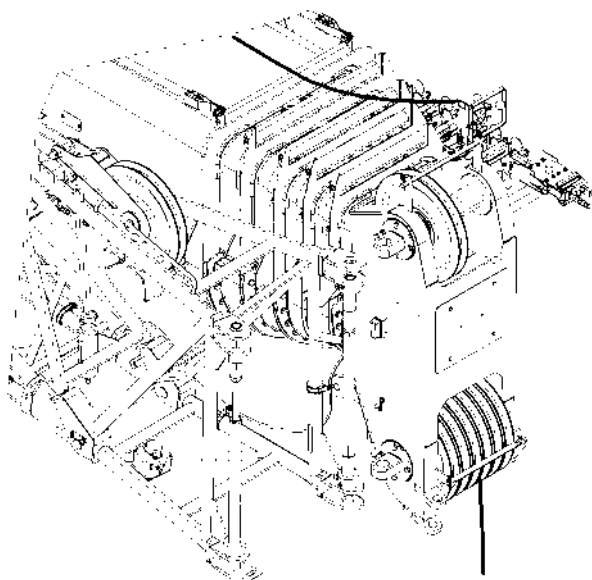

10195

3. Wind/unwind the hoisting rope until the rope end projects above the boom head and stow it to the side. **NOTICE! Do not drag the hoisting rope on the ground.**

4. Fix the guide belt on the 3.8-m-stinger (12.5 ft). Secure the other end of the guide belt to the mobile crane at a suitable point to prevent the fly jib from pivoting out uncontrollably.
5. Connect the remote control.

#### Disconnecting the hydraulic and electrical connections

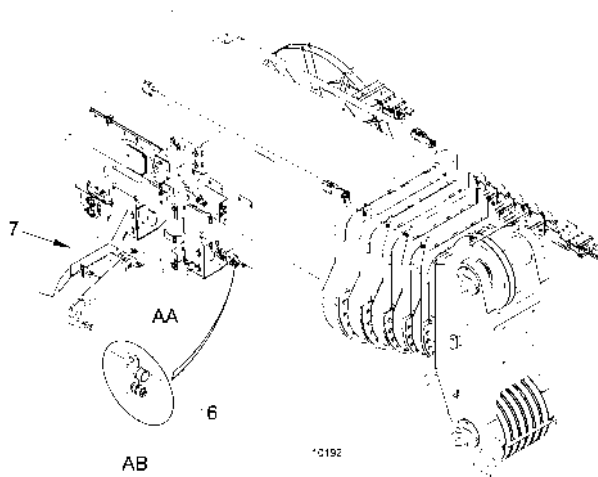

1. Disconnect the luffing jib hydraulic lines on the telescopic boom (6). Observe the following order when disconnecting:
  - ⇒ 1. Disconnect line (AA) for the luff up function.
  - ⇒ 2. Disconnect line (AB) for the luff down function.

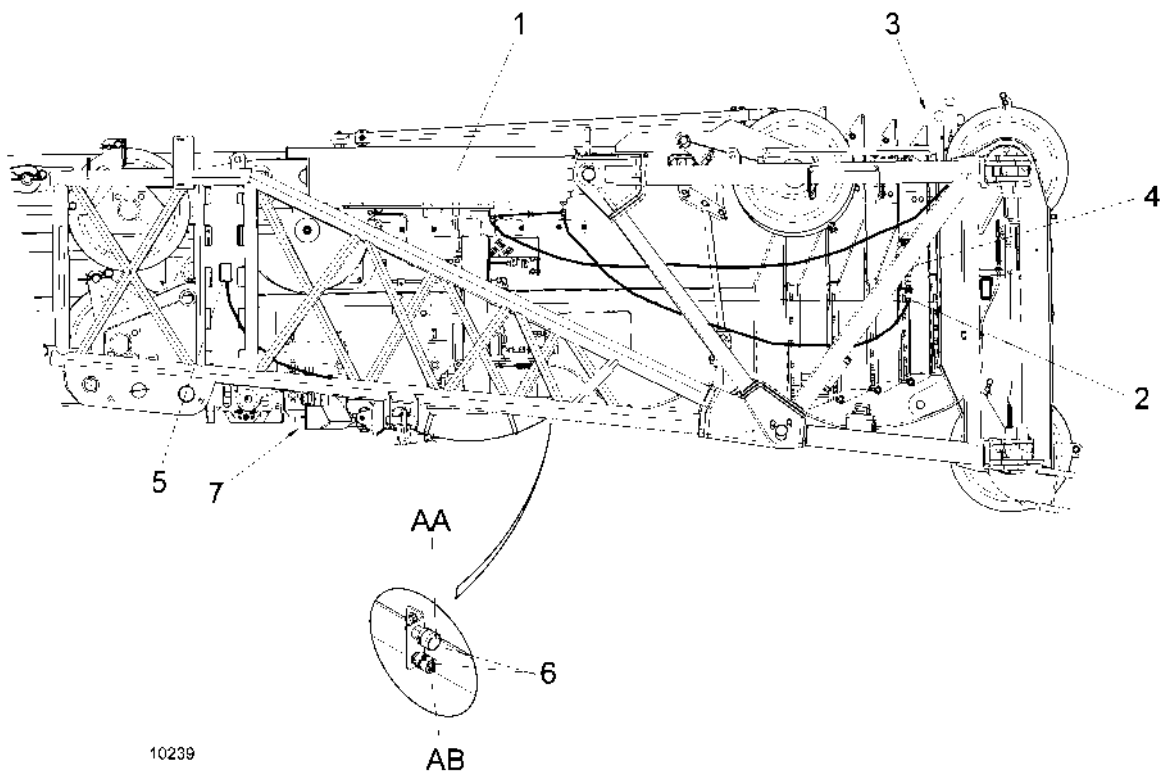

2. Fit protective caps to the hydraulic connections (6). Place the luffing jib hydraulic lines in the clamp-fitted buffer (3) or fit to the expansion tank (4).



3. Disconnect the electrical connection from the telescopic boom (7), plug the line into the dummy connector housing (5) on the luffing jib.

#### Pivoting the fly jib to the boom head

1. Extend the slewing cylinder using the remote control (right lever forwards) until the holes on the 3.8-m-fly jib (12.5 ft) are flush with the holes on the right-hand side of the boom head.

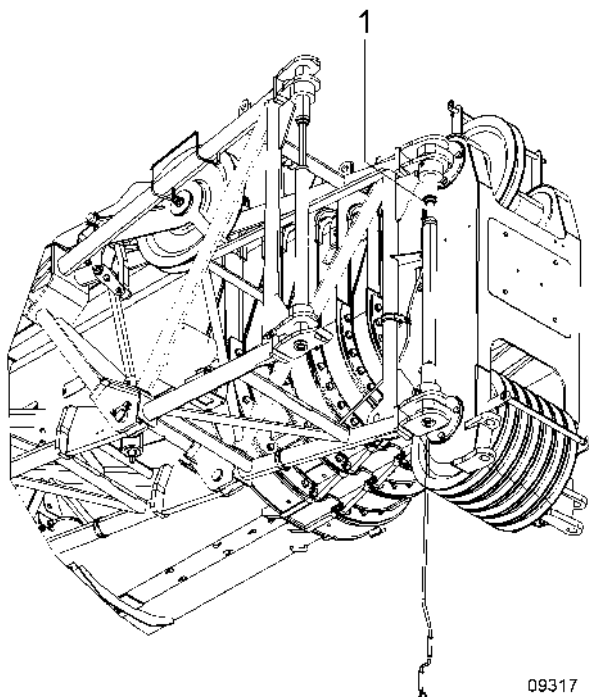

2. Insert the crank handle into the threaded bolt and turn until the third red marking (1) is completely visible. **⚠️ WARNING! The upper and lower bolt elements must be retracted completely (up to the end stop) in the bearing brackets on the boom head. Since both bolt ends are not retracted completely, the stinger may fall.**

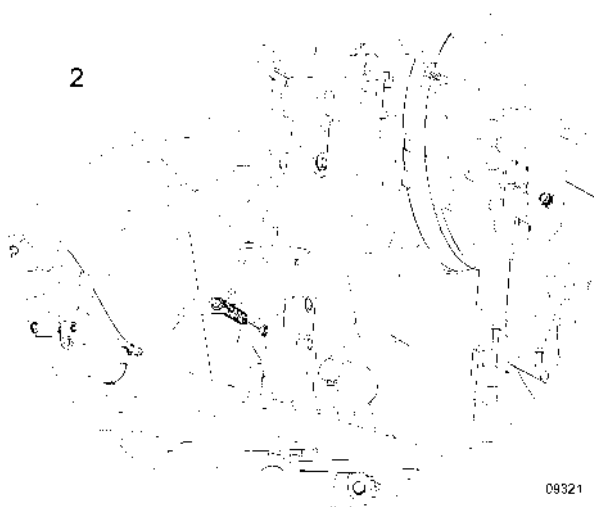

⇒ The safety flap (2) on the locking cylinder was turned using the rope arrangement.

3. Remove the crank handle again.

#### Slewing the fly jib to the boom head

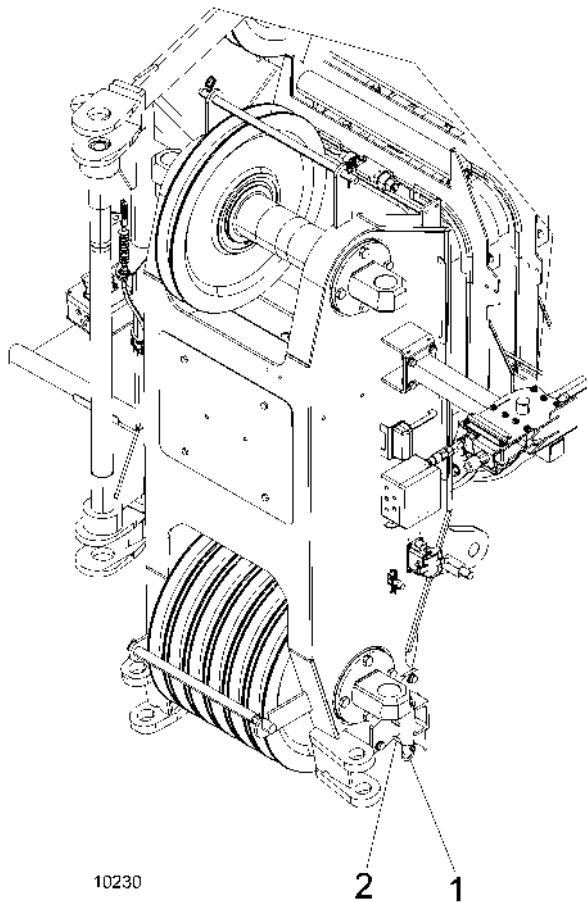

1. Release the lock on the left side of the boom head. For this, pull the ring (1) down and turn it by 90°. The pin (2) points towards the telescopic boom.
2. Loosen the hydraulic locking bolts between the telescopic boom and the stinger using the remote control (the left lever to the back).

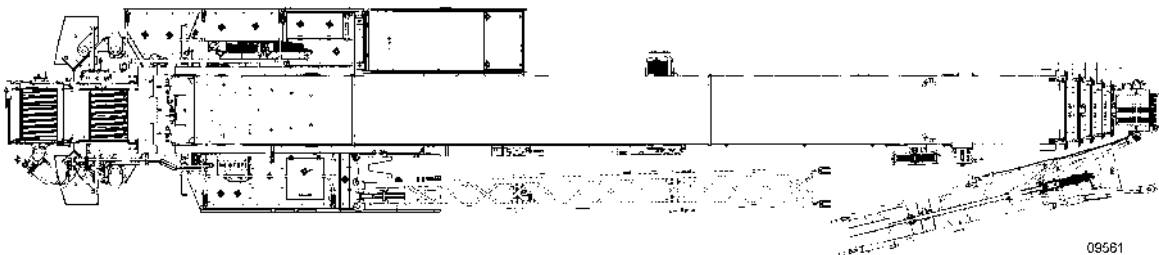

3. Extend the slewing cylinder completely using the remote control (the right lever to the front).  
⇒ The stinger foot rolls from the transporting support.

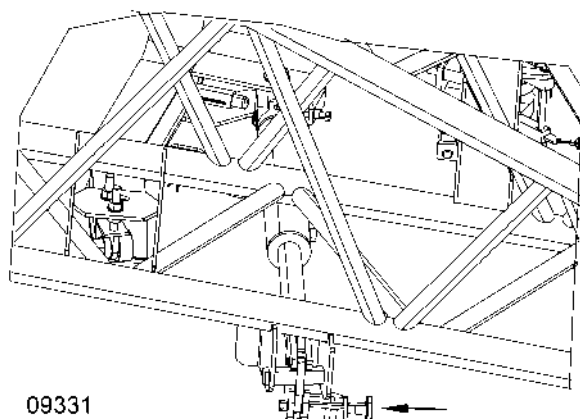

4. Pull the lock on the slewing cylinder.
  - ⇒ The stinger can be swiveled freely.
5. Loosen the guide belt of the mobile crane from below.
6. Swing open the stinger with the guide belt until it engages in the lock on the left side of the boom head.
  - ⇒ The holes on the 3.8-m-fly jib (12.5 ft) align with the holes on the left side of the boom head.

#### Connecting the hydraulic connections

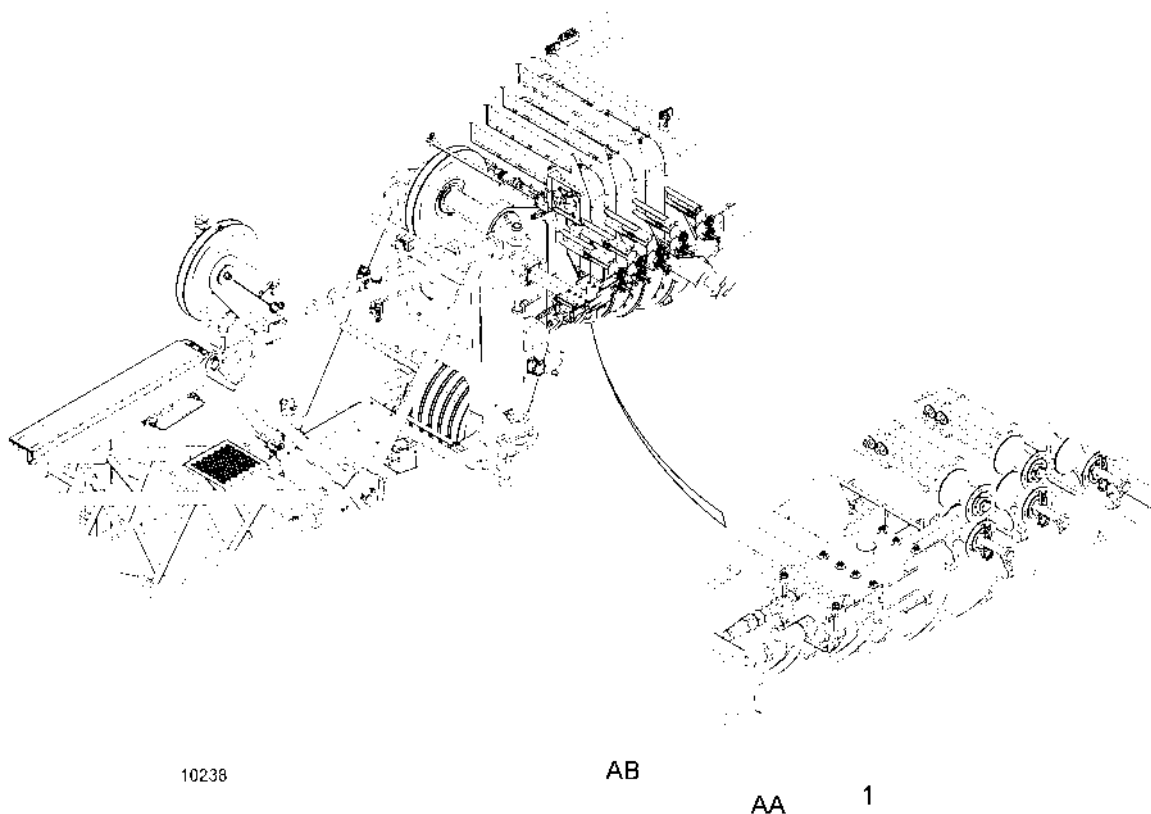

1. Establish a hydraulic connection by removing the hydraulic lines of the 3.8-m-fly jib (12.5 ft) from the clamp-fitted buffer or the expansion tank and connecting them to the connection (1) on the boom. Observe the following order for connecting to the telescopic boom:
  - ⇒ 1. Connect line (AB) for the luff down function.

- ⇒ 2. Connect line (AA) for the luff up function.

### Erecting and securing the sheave

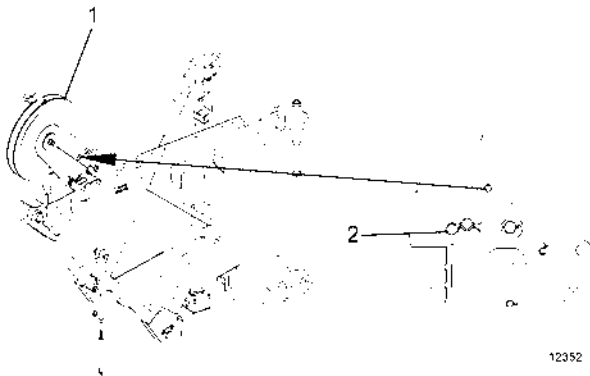

1. Wind the sheave of the 3.8-m-fly jib (12.5 ft) using the crank handle until further turning is not possible and the sheave is completely supported on the adapter. **⚠ CAUTION! If the sheave is not completely supported on the adapter, it may lead to uncontrolled lowering of the lifting load.**
2. Secure the supported sheave with a pin. Secure the pin using a spring clip.
3. Remove the crank handle again.

### Bolting the fly jib on the boom head

1. Unwind the hoisting rope until the rope end projects above the complete fly jib and stow it to the side. **NOTICE! Do not drag the hoisting rope on the ground.**



2. Place the hoisting rope on the sheave of the 3.8-m-stinger foot (12.5 ft). To do so, push the securing clamp (1) down and turn to the locked position (2). Place the hoisting rope on the sheave and turn back the securing clamp.

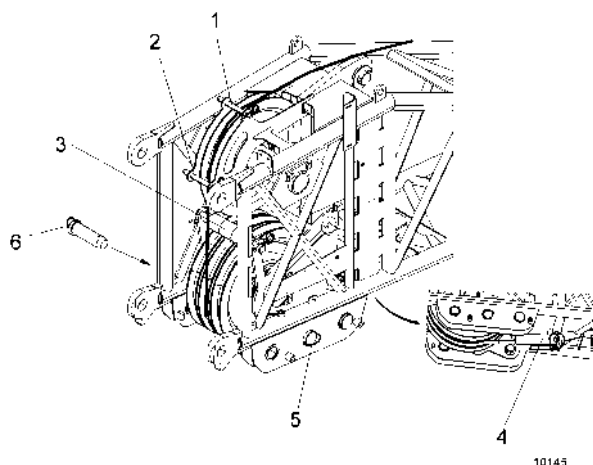

3. Owing to the dead weight of the stinger, the upper threaded bolt cannot be screwed in the upper hole of the bearing bracket as yet. To do this, lift the fly jib slightly using the hoisting gear, after the hoisting rope has been positioned and fixed to the rope fixing point of the fly jib.
4. Insert the crank handle into the threaded bolt and turn until the third red marking is completely visible.

**⚠ WARNING!** The upper and lower bolt elements must be retracted completely (up to the end stop) in the bearing brackets on the boom head. Since both bolt ends are not retracted completely, the stinger may fall!

5. Remove the crank handle again.
6. Establish electrical connection for the anti-two-block device and the aircraft warning lamp\*) between the telescopic boom and the stinger.

### Securing the transporting support

1. Retract the slewing cylinder using the remote control (the right lever to the back).

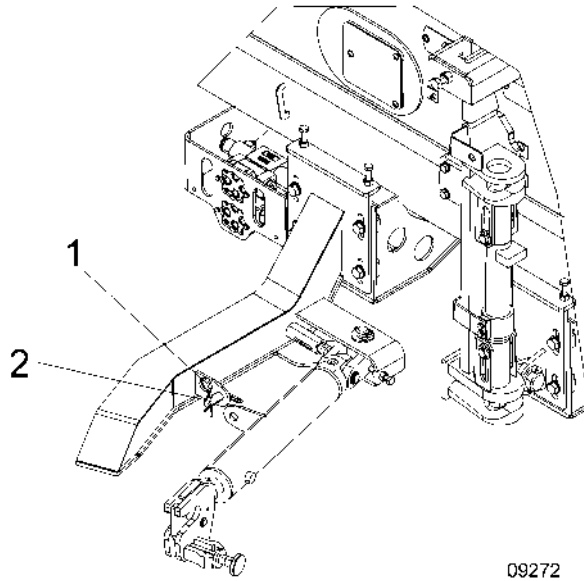

09272

2. Pin the slewing cylinder with the transporting support. Pull the spring clip (1) and bolt (2) for this. Push the slewing cylinder to the left until the hole on the transporting support aligns with the hole on the slewing cylinder. Loosen the bolt (2) and secure with the spring clip (1).
3. Switch off the engine and the ignition.
4. Detach the remote control.
5. Remove the guide belt from the 3.8-m-fly jib (12.5 ft).

#### Folding down the roller carrier - working position

	<p>In the working position, the sheave carrier must be folded down and secured.</p> <p>In the transport position, the sheave carrier must be folded up and secured.</p>
---	---

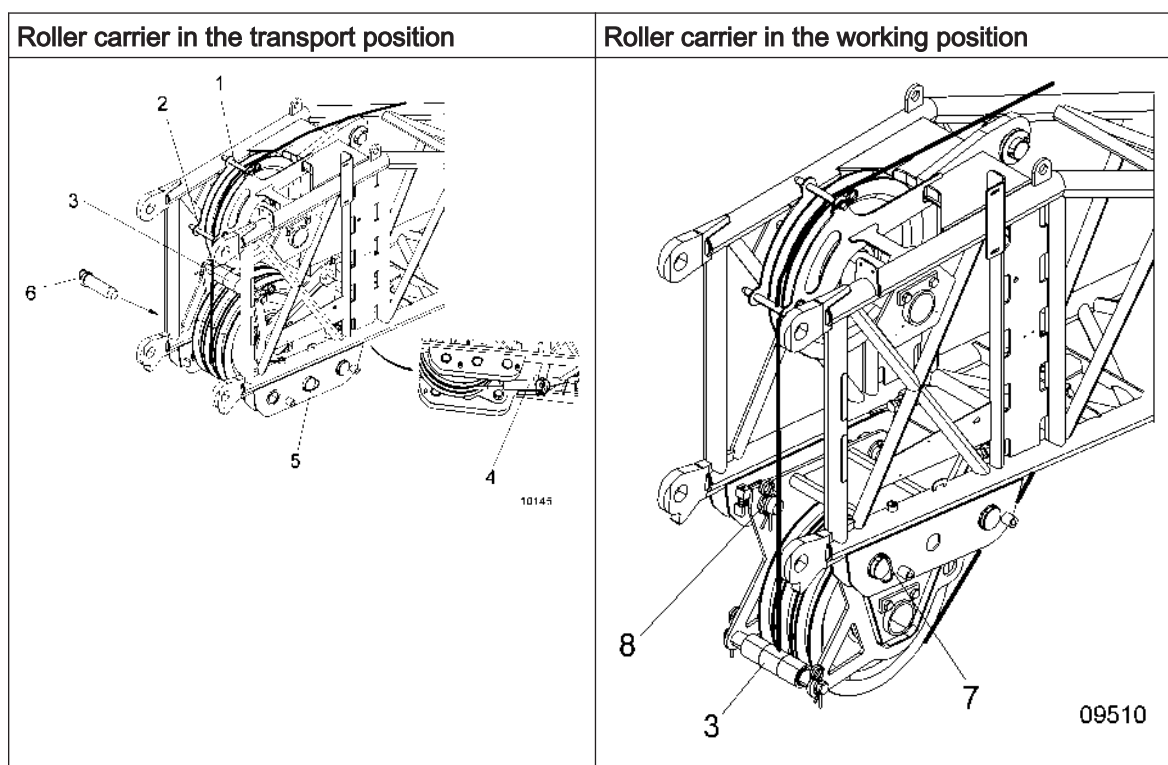

1. Place the hoisting rope on the upper sheave on the head of the 3.8 m (12.5 ft) stinger foot. For this, pull the spring clip and the securing clamps (1), (2). Place the hoisting rope on the sheave and secure again using the securing clamps (1), (2) and the spring clip.
  2. Place the hoisting rope on the sheaves of the roller carrier. Remove the rope holding sheaves (3). For this, pull the spring clip and remove the securing clamp and rollers.
  3. Fix the hoisting rope with the rope clamp at the fixing point of the 3.8 m (12.5 ft) stinger foot (4).
  4. Tension the hoisting rope by carefully winding it in. The pressure on pins (5) and (6) is relieved.
  5. Remove the spring clip and pins from holes (5) and (6).
  6. Unwind the hoisting rope carefully until the sheave carrier folds down up to the end stop.
  7. Pin the sheave carrier. For this, insert the pins into holes (7) and (8) and secure them using the spring clip.
    - ⇒ The sheave carrier is in the working position.
  8. Loosen the hoisting rope from the fixing point.
  9. Reeve the hoisting rope on the sheave carrier and the bottom block.
  10. Secure the hoisting rope using rope holding sheaves (3). For this, attach the securing clamp and rollers again and secure them using the spring clip.
- Fold up the sheave carrier in the transport position in the logical reverse order. **NOTICE! Remove the rope holding sheaves (3) before folding up.**

#### Finishing work

1. Mount the anti-twoblock device, *anemometer* [page 160] and *aircraft warning lamp* [page 162\*]) on the head of the jib.
2. Guide the hoisting rope through the release weight of the anti-twoblock device.
3. Enter the setup condition in the automatic safe load indicator.

#### Installing of the intermediate sections

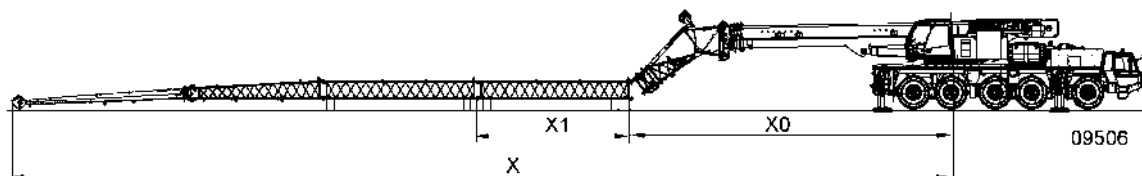

X	Distance from the rotation centre up to the jib head = 42.0 m (137.8 ft)
X0	Distance from the rotation centre up to the 1st intermediate section = 14.5 m (47.6 ft)
X1	Length of an intermediate section = 7.0 m (23.0 ft)

Intermediate sections are mounted between the 3.8-m-stinger (12.5 ft) and the 6.0-m-stinger foot (19.7 ft). **NOTICE! A maximum of two intermediate sections can be mounted.**

#### Prerequisite:

- There should be no obstacles in the movement range.
- The mobile crane is supported as prescribed.
- The slewing gear brake is engaged.
- All telescopes are retracted.
- The superstructure is slewed to the back.
- The telescopic boom is lowered.
- The stinger (3-piece) is mounted at the working position on the telescopic boom.
- The setup mode in the automatic safe load indicator is activated.
- The bottom block was placed on the ground and decoupled. The release weight of the anti-two-block device was removed from the hoisting rope.
- Wind up the hoisting rope under tension until the rope end can be placed in front of the sheave on the 3.8-m-fly jib (12.5 ft). **NOTICE! Do not drag the hoisting rope on the ground.**

1. Lower the mobile crane using the rear outriggers.

#### Separating the 6.0 m (19.7 ft) stinger foot with the boom end from the 3.8 m (12.5 ft) stinger foot

The 6.0-m-stinger foot (19.7 ft) remains pinned with the boom end.

1. Disconnect the electrical connection for the anti-twoblock device and the aircraft warning lamp\*) between the 3.8-m-stinger (12.5 ft) and the 6.0-m-stinger foot (19.7 ft).
2. Lower the telescopic boom completely and unwind the hoisting rope until the boom end slightly above the ground.
3. Luff up the fly jib.



**⚠ DANGER!** Luff down the telescopic boom with jib carefully. If the jib hits the ground, the jib and/or mobile crane may be damaged.

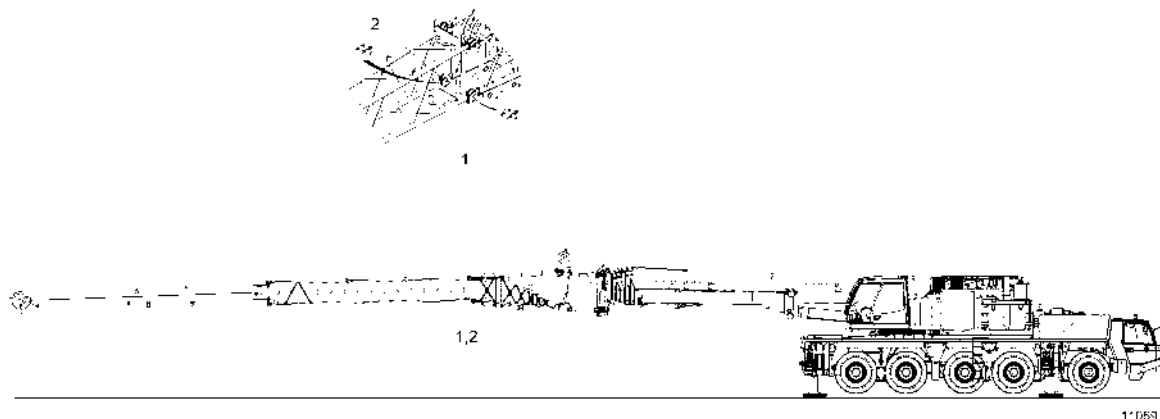

1. Remove both the lower pins (1) and (2). For this, pull the spring clip and pins, insert them into the pin compartment and secure them.
2. Carefully luff down the fly jib until the boom tip and the 6.0-m-fly jib foot (19.7 ft) are resting on the ground. Support the tip properly or position the mobile crane at an angle (retract the rear outrigger cylinders, extend the front outrigger cylinders).

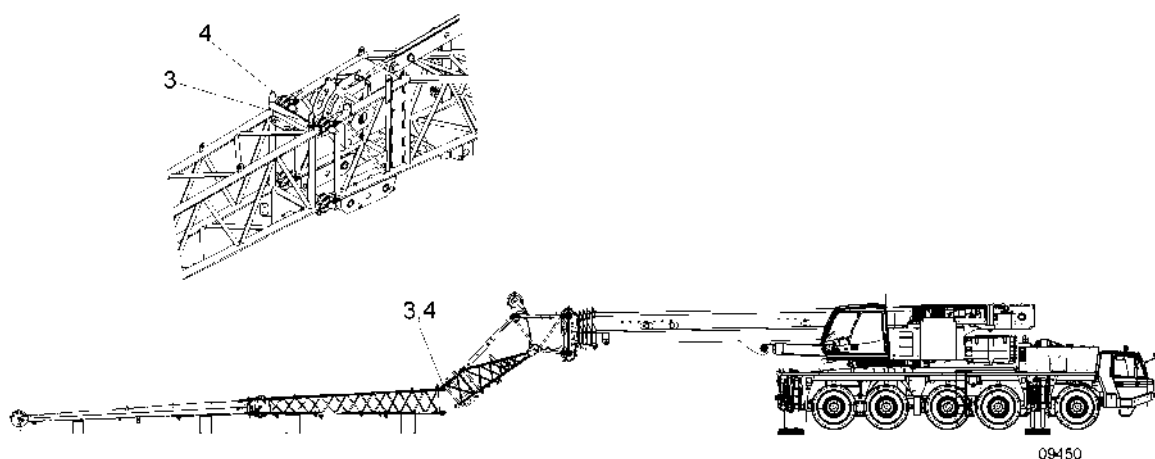

3. Remove both the upper pins (3) and (4). For this, pull the spring clip and pins, insert them into the pin compartment and secure them.

#### Attaching the intermediate sections

Position the intermediate section(s) and the 6.0 m (19.7 ft) stinger foot with the boom end in front of the 3.8 m (12.5 ft) stinger foot such that they can be attached one after the other.

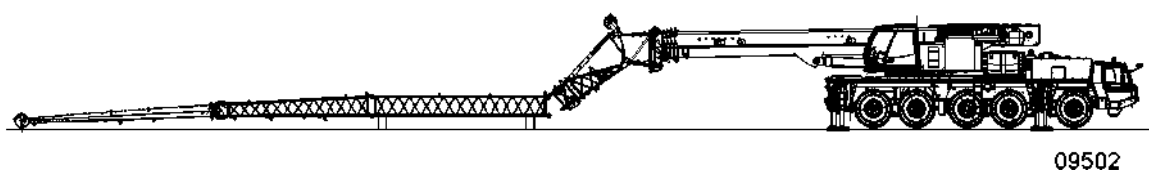

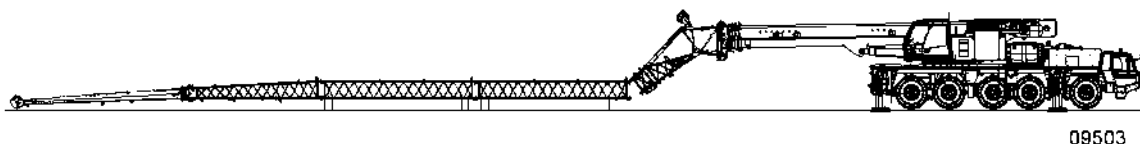

09503

#### Attaching the first intermediate section

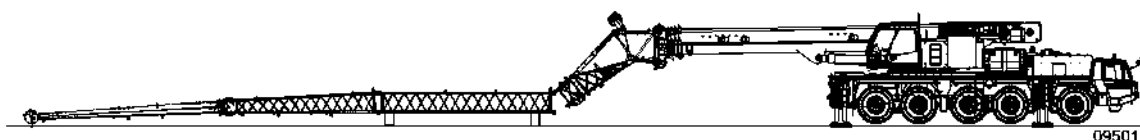
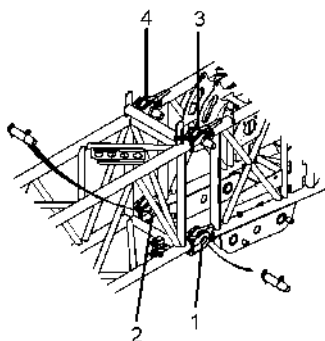

09501

- The 3.8-m-stinger (12.5 ft) is bent to 40°.
  - The jib is properly supported or the mobile crane is positioned at an angle (rear outrigger cylinders are retracted, front outrigger cylinders are extended).
1. Luff up the telescopic boom until the upper holes of the 3.8-m-fly jib (12.5 foot) (3) and (4) align with the upper holes of the first intermediate section.
  2. Remove the pins from the pin compartment of the intermediate section, insert them into holes (3) and (4) sideways and secure them using the spring clip.
  3. Raise the telescopic boom carefully until the intermediate section no longer touches the ground and the lower holes of the 3.8-m-stinger (12.5 ft) (1) and (2) align with the lower holes of the intermediate section.
  4. Remove the pins from the pin compartment of the intermediate section, insert them into holes (1) and (2) sideways and secure them using the spring clip.
  5. Establish an electrical connection for the anti-twoblock device and the aircraft warning lamp\* between the 3.8-m-stinger foot (12.5 ft) and the intermediate section.

### Attaching the second intermediate section

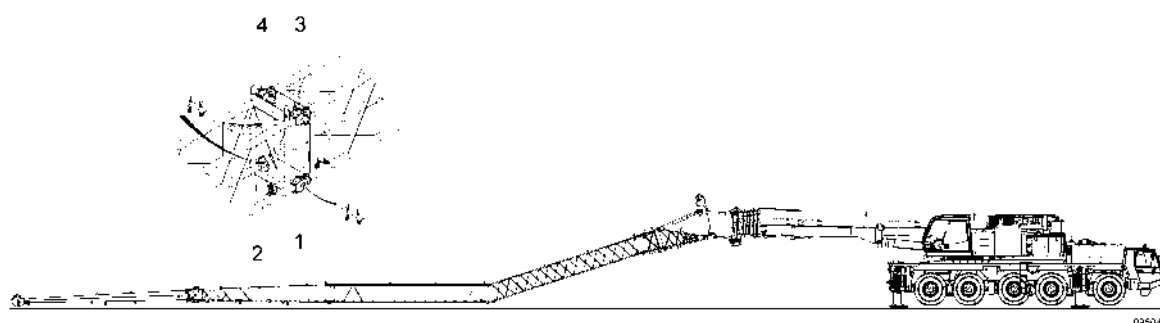

➤ The 3.8-m-stinger (12.5 ft) is bent to approx. 20°.

1. Luff up the telescopic boom until the upper holes of the first intermediate section (3) and (4) align with the upper holes of the second intermediate section.
2. Remove the pins from the pin compartment of the intermediate section, insert them into holes (3) and (4) sideways and secure them using the spring clip.
3. Raise the telescopic boom carefully until the second intermediate section no longer touches the ground and the lower holes of the first intermediate section align with the lower holes of the second intermediate section.
4. Remove the pins from the pin compartment of the intermediate section, insert them into holes (1) and (2) sideways and secure them using the spring clip.
5. Establish an electrical connection for the anti-twoblock device and the aircraft warning lamp\*) between both the intermediate sections.

### Attaching the 6.0 m (19.7 ft) stinger foot with the boom end

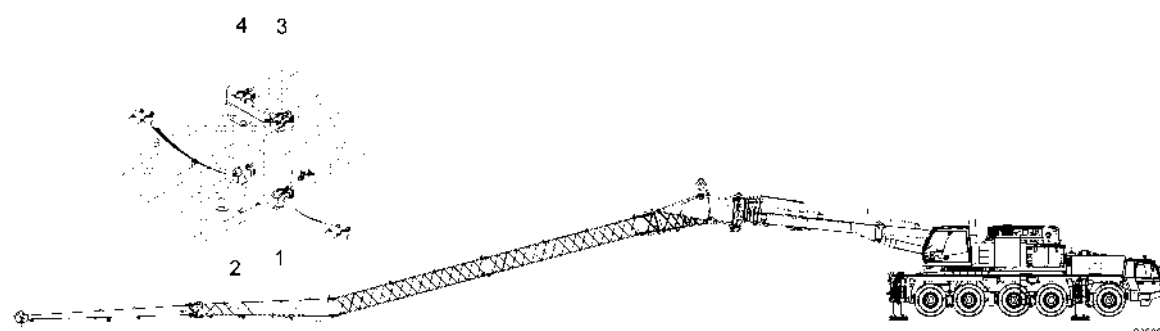

1. Luff up the telescopic boom until the upper holes of the intermediate section (3) and (4) are flush with the upper holes of the 6.0-m-fly jib foot (19.7 ft).
2. Remove the pins from the pin compartment of the 6.0-m-fly jib foot (19.7 ft), insert them laterally into holes (3) and (4) and secure them with spring clips.
3. Carefully luff up the telescopic boom until the boom tip no longer touches the ground and the lower holes of the intermediate section are flush with the lower holes of the 6.0-m-fly jib foot (19.7 ft).

4. Remove the pins from the pin compartment of the 6.0-m-fly jib foot (19.7 ft), insert them laterally into holes (1) and (2) and secure them with spring clips.
5. Establish an electrical connection for the anti-twoblock device and the aircraft warning lamp\* between the intermediate section and the 6.0-m-fly jib foot (19.7 ft).
6. Unwind the hoisting rope under tension along the entire length of the jib.
7. Place the hoisting rope on the sheave of the boom tip. To do this, pull the spring clip, remove the securing clamp and fit the hoisting rope. Secure the hoisting rope again with the securing clamp and spring clip.

### Finishing work

1. Lift the mobile crane using the rear outriggers again and level it.
2. Mount the anti-twoblock device, anemometer and aircraft warning lamp\* on the head of the jib.
3. Guide the hoisting rope through the release weight of the anti-twoblock device.
4. Mount the bottom block.
5. Enter the setup condition in the automatic safe load indicator.

### See also

- 📖 Aircraft warning lamp\* [→ 162]
- 📖 Anemometer [→ 160]
- 📖 Hook tackle/bottom block [→ 403]

### Attaching the boom tip, the 6.0-m-fly jib foot (19.7 ft) and intermediate sections

- The 7.5-m-boom tip (24.6 ft), 6.0-m-fly jib foot (19.7 ft) and the two intermediate sections are bolted together and positioned in front of the mobile crane so that they can be attached to the 3.8-m-fly jib (12.5 ft).
- The telescopic boom is lowered.
- The 3.8-m-stinger (12.5 ft) is bent to 40°.
- The jib is properly supported or the mobile crane is positioned at an angle (rear outrigger cylinders are retracted, front outrigger cylinders are extended).
- Establish an electrical connection for the anti-twoblock device and the aircraft warning lamp\* between the 7.5-m-boom tip (24.6 ft), the 6.0-m-fly jib foot (19.7 ft) and the two intermediate sections.

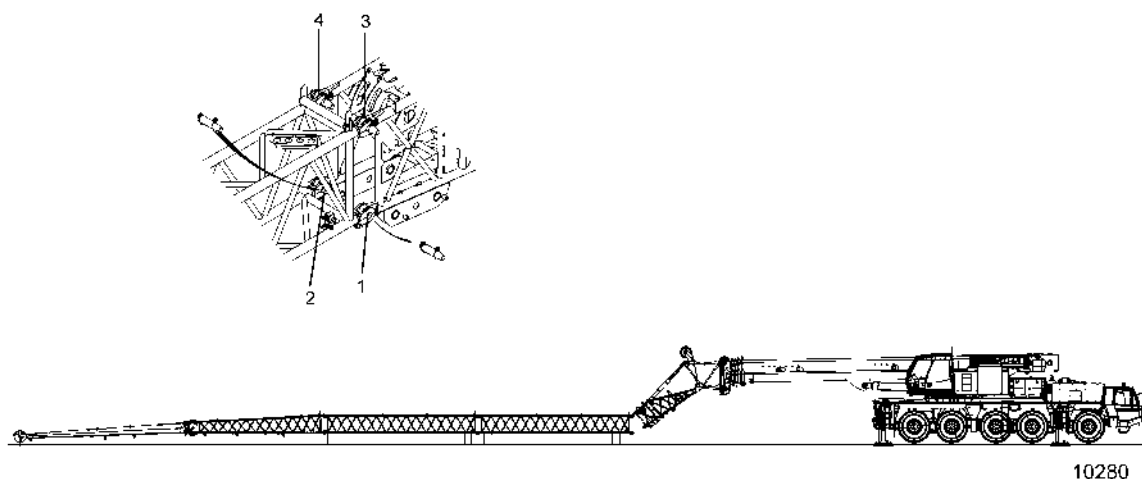

1. Luff up the telescopic boom until the upper holes of the 3.8-m-fly jib foot (12.5 ft) (3) and (4) are flush with the upper holes of the intermediate section.
2. Remove the pins from the pin compartment of the intermediate section, insert them into holes (3) and (4) sideways and secure them using the spring clip.
3. Carefully luff up the telescopic boom until the boom tip no longer touches the ground and the lower holes of the intermediate section are flush with the lower holes of the boom tip.
4. Remove the pins from the pin compartment of the intermediate section, insert them into holes (1) and (2) sideways and secure them using the spring clip.
5. Establish electrical connection for the anti-twoblock device and the aircraft warning lamp\*) between the jib and the 3.8-m-fly jib (12.5 ft).
6. Unwind the hoisting rope under tension along the entire length of the jib.
7. Place the hoisting rope on the sheave of the boom tip. To do this, pull the spring clip, remove the securing clamp and fit the hoisting rope. Secure the hoisting rope again with the securing clamp and spring clip.

### Finishing work

1. Lift the mobile crane using the rear outriggers again and level it.
2. Mount the anti-twoblock device, anemometer and aircraft warning lamp\*) on the head of the jib.
3. Guide the hoisting rope through the release weight of the anti-twoblock device.
4. Mount the bottom block.
5. Enter the setup condition in the automatic safe load indicator.

### Examples of rope reeving

Depending on the required lifting load, determine the bottom block and the required number of rope falls with the help of "Notes regarding the lifting capacity chart" and the lifting capacity charts.

Reeve the hoisting rope depending on the required number of rope falls as described below:

**i** If possible, the reeving in the bottom block should be done such that the bottom block is suspended vertically especially in case of a small number of ropes.

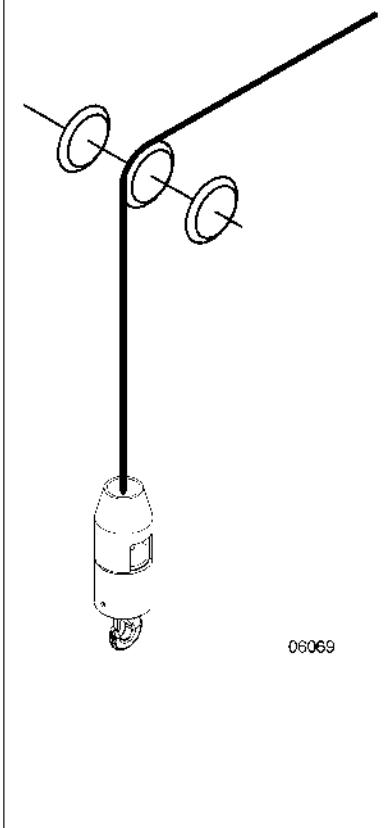
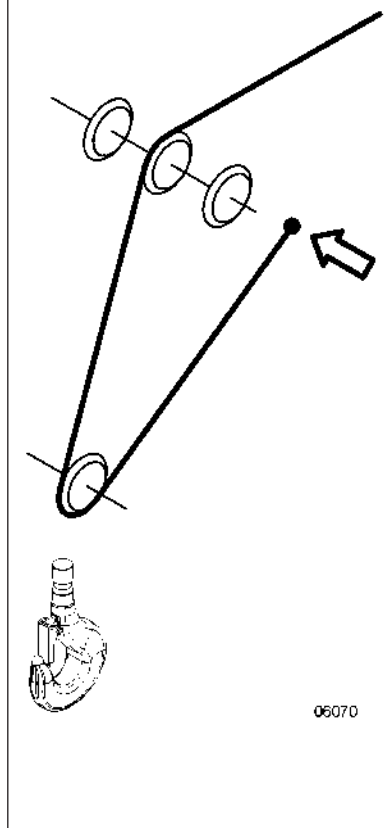
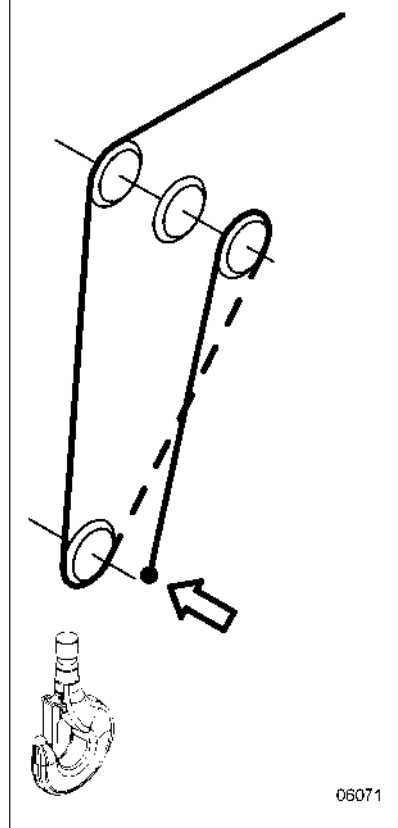
Bottom block, 1-sheave 1-line reeved	Bottom block, 1-sheave 2-line reeved	Bottom block, 1-sheave 3-line reeved
 <p>Diagram showing a single rope line from the top sheave to the bottom sheave. The bottom block is suspended vertically. Reference number 06069.</p>	 <p>Diagram showing two rope lines from the top sheave to the bottom sheave. The bottom block is tilted. Reference number 06070.</p>	 <p>Diagram showing three rope lines from the top sheave to the bottom sheave. The bottom block is tilted. Reference number 06071.</p>

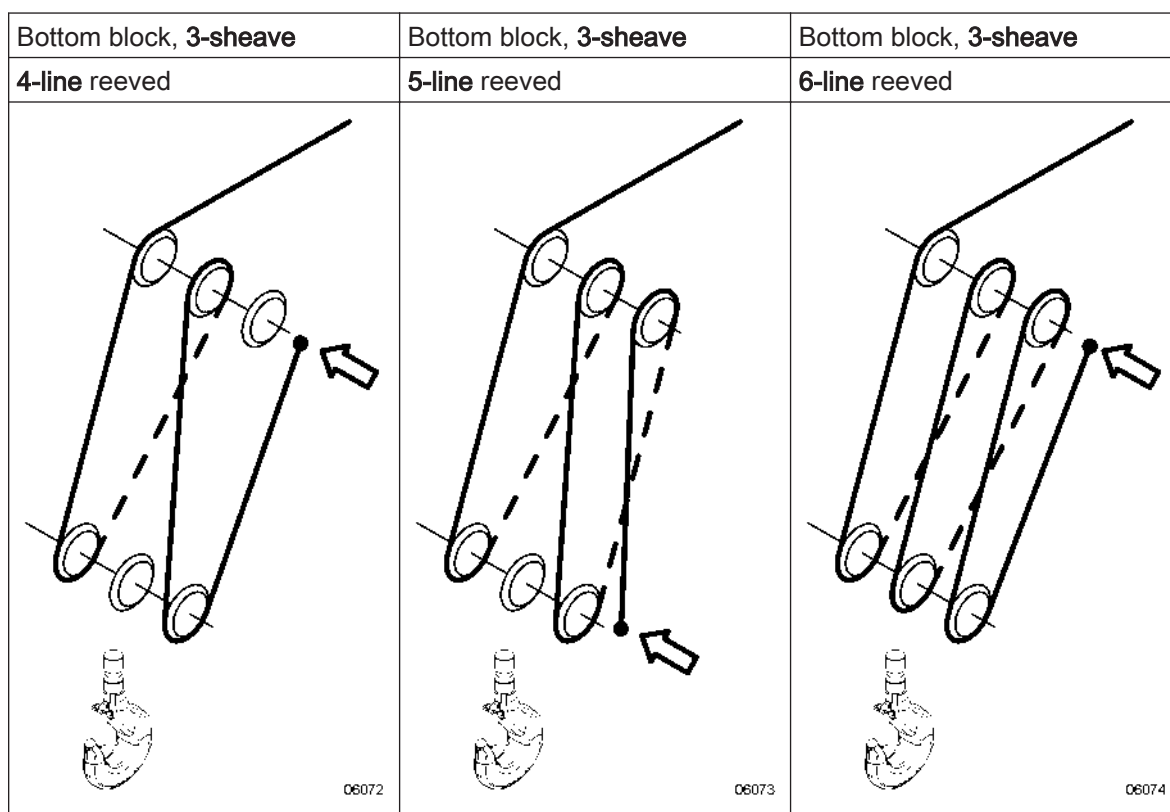

**i** If the 3.8 m (12.5 ft) fly jib is at a small angle, the maximum angle of the boom is limited by the automatic safe load indicator to prevent the hoisting rope colliding with the lower sheaves on the boom head.



### Removing of the fly jib - transport position



#### Requirements

- The mobile crane is supported as prescribed.
- The slewing gear brake is engaged.
- All telescopes are retracted.
- The superstructure is slewed to the back or side.
- The telescopic boom is luffed down (0° position).
- The jib is luffed up (0° position).
- The bottom block was placed on the ground and decoupled. The rope clamp and the release weight of the anti-twoblock device were removed from the hoisting rope.
- The double ladder, crank handle and the remote control for the slewing cylinder are ready.

	 <b>WARNING</b>
	<p><b>Risk of skidding and accident!</b></p> <p>When climbing and stepping on ladders and access ladders, take utmost care especially in case of humid weather.</p> <ol style="list-style-type: none"> <li>1. Always keep the ladders and access ladders clean.</li> <li>2. Remove dirt and other greasy substances immediately and thoroughly.</li> <li>3. Always hold the ladder beams or handles while climbing up or down.</li> <li>4. Wear non-slip shoes and keep them clean.</li> <li>5. Ensure that the ladders are safe.</li> </ol>

- The pressure gauge on the jib hydraulic cylinder shows more than 100 bar (1450.4 psi).

**Checking the hydraulic oil pressure in the hydraulic cylinder of the fly jib**

	 <b>WARNING</b>
	<p><b>Insufficient pressure in the hydraulic cylinder!</b></p> <p>If the pressure in the hydraulic cylinder is too low, the jib may fold down uncontrollably when it is pivoted back.</p> <ol style="list-style-type: none"> <li>1. Every time the jib is to be pivoted back, you must first check that the pressure in the hydraulic cylinder is more than 100 bar (1450.4 psi).</li> <li>2. If the pressure shown is less than 100 bar (1450.4 psi), the jib must not be pivoted back.</li> </ol>

There is a pressure gauge under the hydraulic cylinder (1) for the hydraulically angled jib.

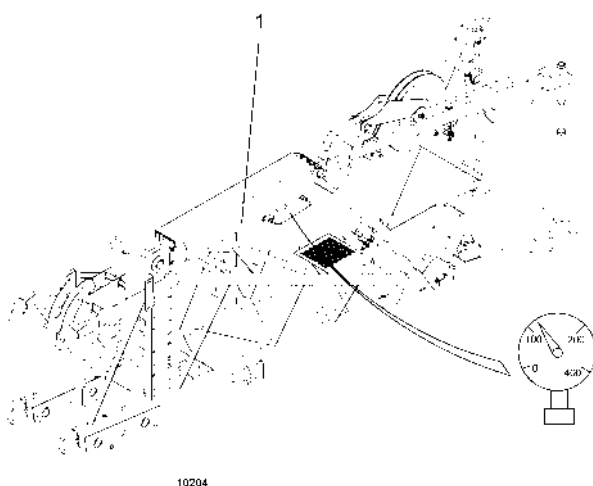

If the pressure gauge shows a pressure of less than 100 bar (1450.4 psi), the pressure must be increased.

To build up the pressure in the hydraulic cylinder, proceed as follows:



1. Switch on the battery main switch and the ignition in the crane cab. Start the superstructure engine.
2. Operate the "Activate jib luffing" rocker switch.
3. Carefully operate the crane control lever in the "Raise luffing jib" function until the pressure gauge shows a pressure of more than 100 bar (1450.4 psi).

The "Jib, luffing cylinder not retracted" warning lamp must not light up as you do this.

### Preparations

1. Remove the anti-twoblock device, anemometer and aircraft warning lamp\*) from the head of the jib. Fit the anti-twoblock device to the 3.8-m-fly jib (12.5 ft), secure the anemometer and aircraft warning lamp\*) to the holder for the anemometer and aircraft warning lamp\*) in the cab.
2. Detach electrical connections for the anti-twoblock device and the aircraft warning lamp\*) between all parts of the jib.
3. When the boom end is dismantled: Remove the hoisting rope from the sheave of the boom end. For this, pull the spring clip, remove the securing clamp and remove the hoisting rope. Insert the securing clamp again and secure it using the spring clip.
4. Remove the hoisting rope from the sheave of the 3.8-m-fly jib (12.5 ft). To do so, push the securing clamp down and pivot to the locked position, then remove the hoisting rope. Pivot the securing clamp back.
5. Start the superstructure engine.
6. Activate the  setup mode in the automatic safe load indicator.
7. Wind up the hoisting rope under tension and place the rope end in front of the sheave on the 3.8-m-fly jib (12.5 ft).
8. Switch off the superstructure engine.

### Removing the boom tip

1. Fix the guide belt on the head of the boom end.

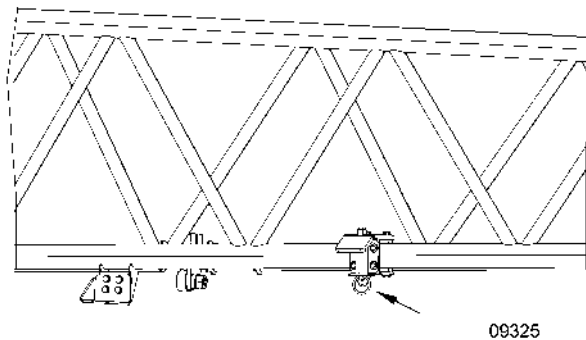

- Loosen the lock. For this, pull the retaining spring washer (using the crank handle) and turn it by 90°.

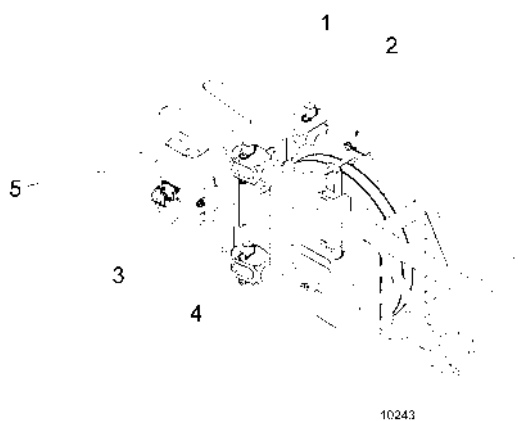

- Remove pins from holes (3) and (4). For this, pull the spring clip, pull out the pins, insert them into the pin compartment (5) and secure them.

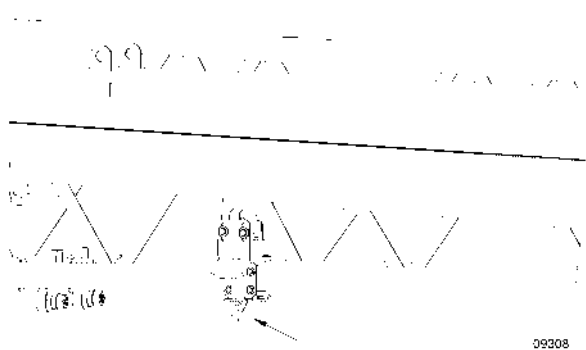

- Slew back the boom end using the guide belt until the lock engages.  
⇒ The boom tip is fixed on the 6.0-m-fly jib foot (19.7 ft).
- Loosen the guide belt from the boom tip.

## Removing the fly jib

### Preparing the transporting support

➤ Electrical connections for the anti-twoblock device and the aircraft warning lamp\*) is disconnected.

1. Fix the guide belt on the head of the 6.0-m-stinger foot (19.7 ft).

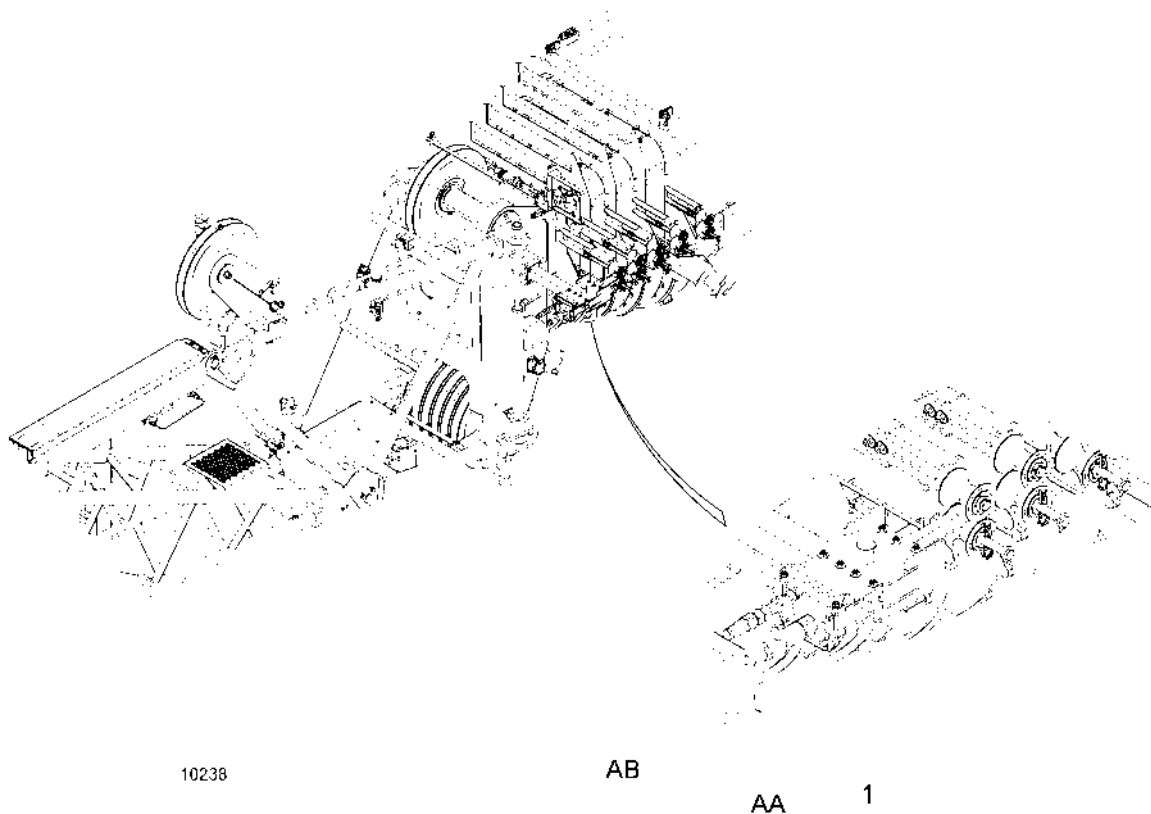

2. Disconnect the jib hydraulic lines on the telescopic boom (1). Observe the following order when disconnecting:
  - ⇒ 1. Disconnect line (AA) for the luff up function.
  - ⇒ 2. Disconnect line (AB) for the luff down function.

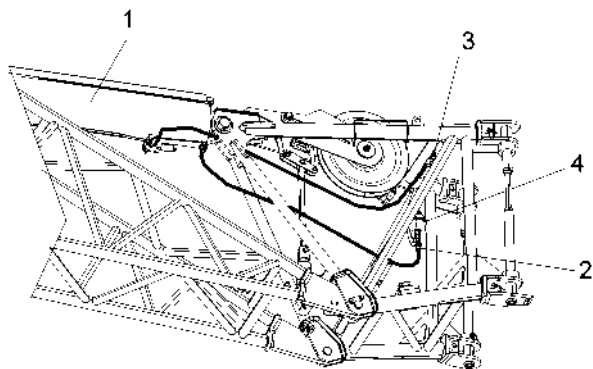

10208

3. Fit protective caps to the hydraulic connections (1) on the boom. Place the jib hydraulic lines in the clamp-fitted buffer (3) or connect to the expansion tank (4).

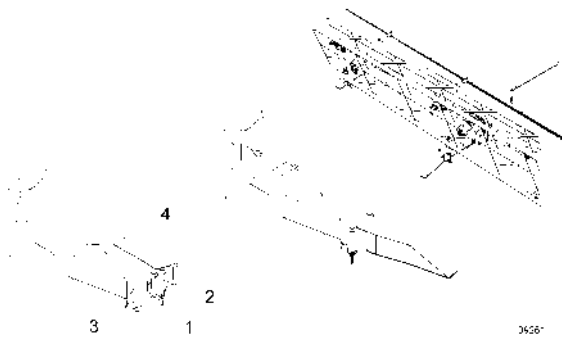

3656

4. Fold out the middle transporting support. Remove the folding plug (1) and pull the bolt (2) downwards. Fold out the transporting support extension (4), insert the bolt (2) in the hole (3) from bottom and secure using the folding plug (1).

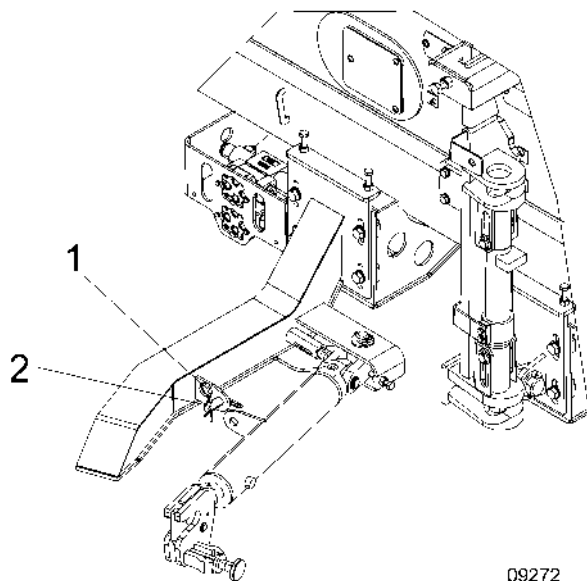

09272

5. Loosen the pin between the slewing cylinder and the transporting support. Pull the spring clip (1) and bolt (2) for this. Press the slewing cylinder to the right. Re-insert the bolt (2) into the hole of the transporting support and secure using the spring clip (1).

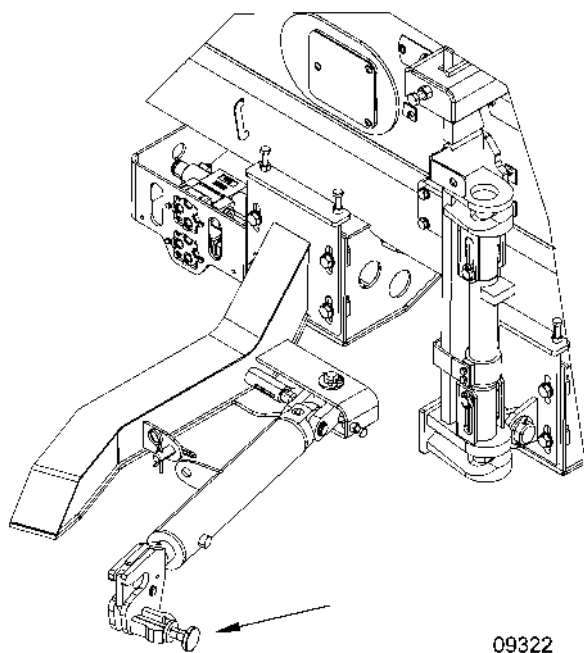

09322

6. Pull the lock on the slewing cylinder until the hook lock opens.
7. Connect the remote control.
8. Start the superstructure engine.

### Removing the hoisting rope

1. Extend the slewing cylinder completely using the remote control (the right lever to the front).
2. Due to the dead weight of the fly jib, the upper threaded bolt cannot yet be unscrewed from the upper hole of the bearing bracket. To do this, lift the fly jib slightly using the hoisting gear, after the hoisting rope has been positioned and fixed to the rope fixing point of the 6.0-m-fly jib foot (19.7 ft).

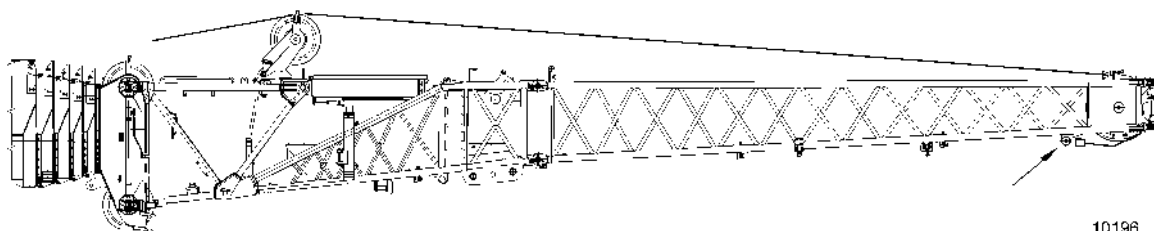

10196

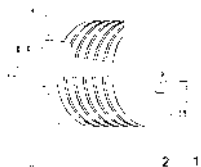

3. Check the lock on the left-hand side of the boom head. Pin (2) must point towards the telescopic boom. **⚠ DANGER!** If the lock is not engaged, the fly jib may pivot out uncontrollably when pins are removed.

4. Loosen the pin on the left side of the boom head. Insert the crank handle into the threaded bolt and turn it up to the end stop.

**NOTICE! The upper and lower bolt elements must be extended from the holes of bearing brackets on the boom head.**

5. Remove the crank handle again.
  6. Release the hoisting rope from the rope fixing point on the 6.0-m-fly jib foot (19.7 ft), wind it up under tension until the end of the rope protrudes over the boom head and stow it to the side. For this, pull the spring clip, remove the securing clamp and remove the hoisting rope. Refit the securing clamp and secure with the spring clip. Next, take the hoisting rope from the sheave on the 3.8-m-fly jib (12.5 ft) by pushing the securing clamp down and turning it to the locked position. Turn the securing clamp back up once you have taken out the hoisting rope.
- NOTICE! Do not drag the hoisting rope on the ground.**

#### Connecting the fly jib with the locking cylinder

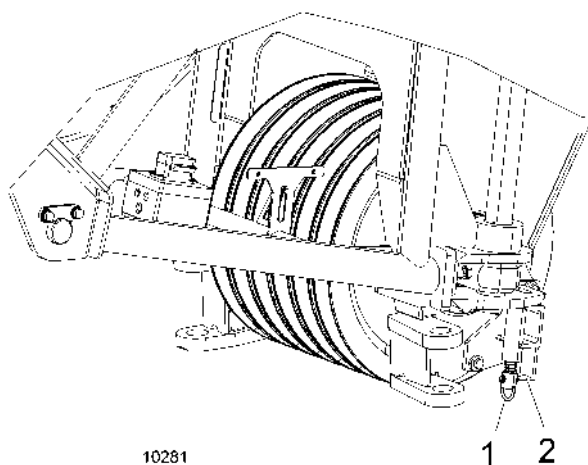

1. Loosen the lock on the left side of the boom head. For this, pull the ring (1) down and turn it by 90°.

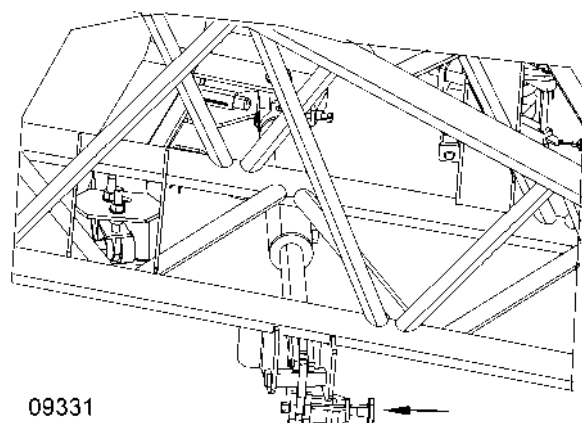

2. Slew back the stinger using the guide belt until it engages in the lock of the slewing cylinder.

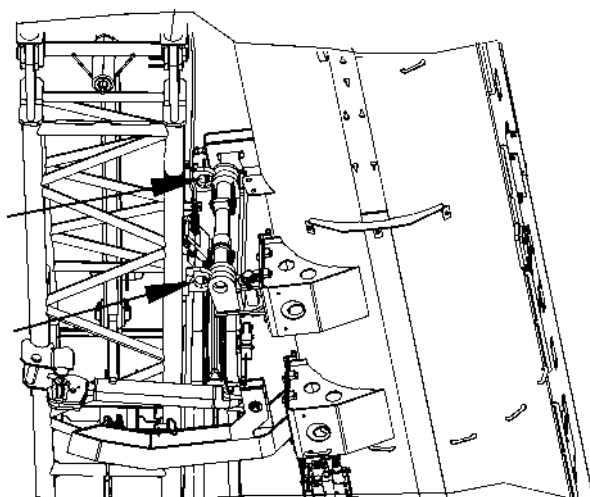

09324

3. Retract the slewing cylinder using the remote control (the right lever to the back) until the holes on the locking cylinder align with the holes on the 6.0-m-stinger foot (19.7 ft).
4. Pin the stinger with the telescopic boom. Extend the locking bolts using the remote control (the left lever to the front). **⚠️WARNING! The locking cylinder must be extended completely. If the locking cylinder is not fully extended, the fly jib may fall.**

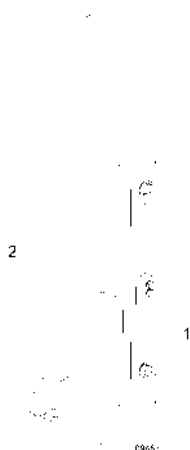

5. Check whether the locking cylinder is extended completely. The height of the tip of the indicator arrow (1) and the tip of the red marking (2) must be the same.

#### Releasing the fly jib from the boom head

1. Release the slewing cylinder. Extend the slewing cylinder by 1 to 2 mm (0.039-0.078 in) using the remote control (the right lever to the front).

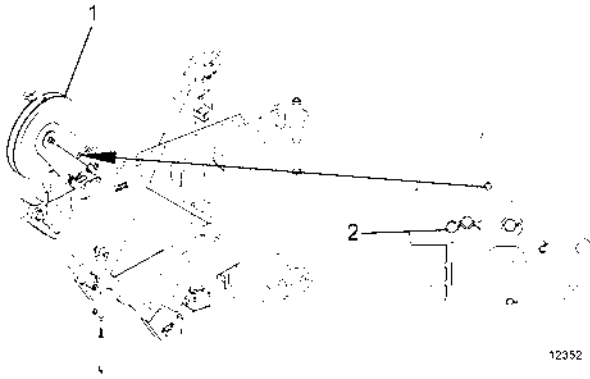

2. Remove spring clips and pins.
3. Wind down the sheave on the 3.8-m-stinger (12.5 ft) up to the end stop using the crank handle.

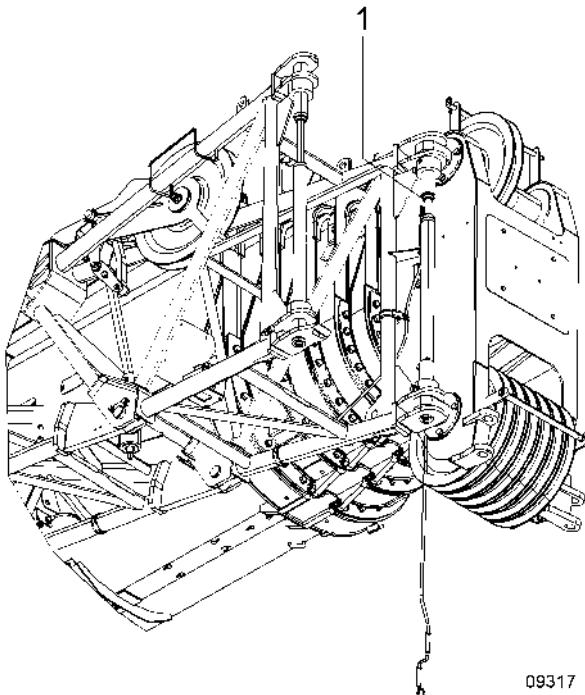

4. Loosen the pin on the right side of the boom head. Insert the crank handle into the threaded bolt and turn it up to the end stop. **NOTICE! The upper and lower bolt elements must be extended from the holes of bearing brackets on the boom head.**



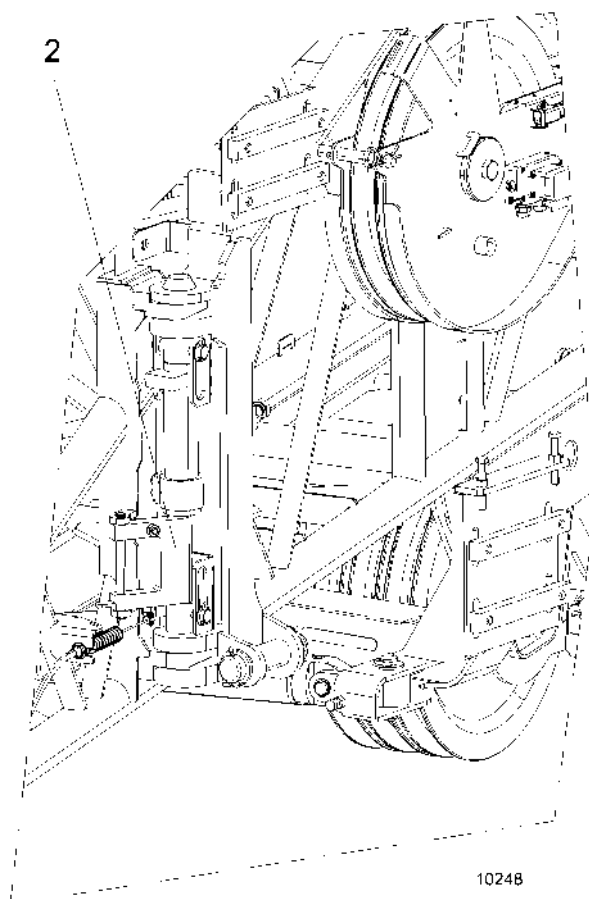

⇒ The safety flap (2) is fixed on the locking cylinder.

5. Remove the crank handle again.
6. Retract the slewing cylinder up to the end stop using the remote control (the right lever to the back).

### Pinning the fly jib on the telescopic boom

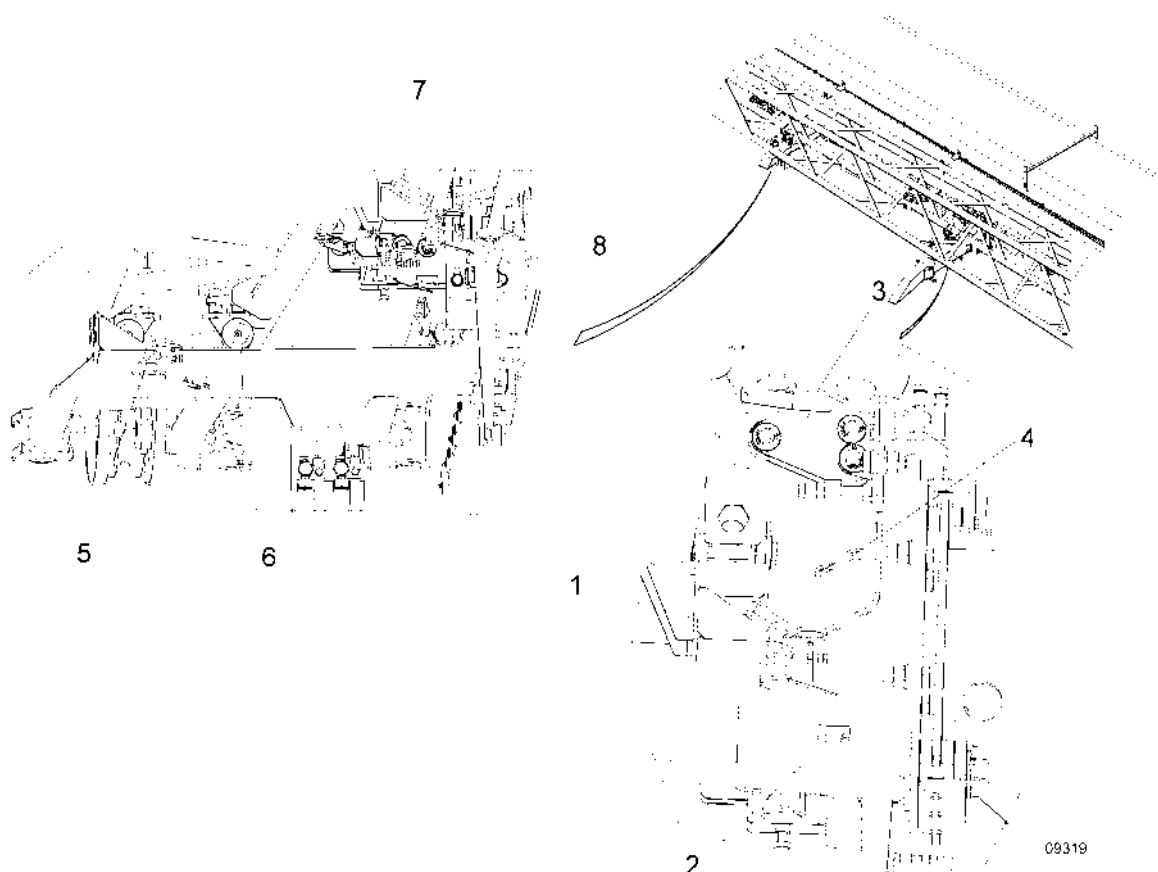

1. Fix the pins (1) and (3) on the **middle** transporting support.  
Pull the locking pin from the pin holder (2), insert it into the hole (1) and secure it again using the spring clip.  
Pull the locking pin from the pin holder (4), insert it into the hole (3) and secure it again using the spring clip.
2. Fix the pins (5) and (7) on the **rear** transporting support.  
Pull the locking pin from the pin holder (6), insert it into the hole (5) and secure it again using the spring clip.  
Pull the locking pin from the pin holder (8), insert it into the hole (7) and secure it again using the spring clip.
3. Remove the guide belt from the 6.0-m-stinger foot (19.7 ft).
4. Switch off the engine and the ignition.
5. Detach the remote control.
6. Fold back the middle transporting support, pin and secure it.

### Connecting the hydraulic and electrical lines

1. Remove the hydraulic lines on the hydraulic cylinder (1) from the storage position (2) on the expansion tank (4) and from the clamp-fitted buffer (3) and connect them to the appropriate ports (6) on the telescopic boom. Observe the following order when connecting:

- ⇒ 1. Connect line (AB) for the luff down function.
  - ⇒ 2. Connect line (AA) for the luff up function.
2. Remove the electrical line for the "Jib, luffing cylinder not retracted" display from the dummy connector housing (5) on the boom foot and connect it to the telescopic boom (7).

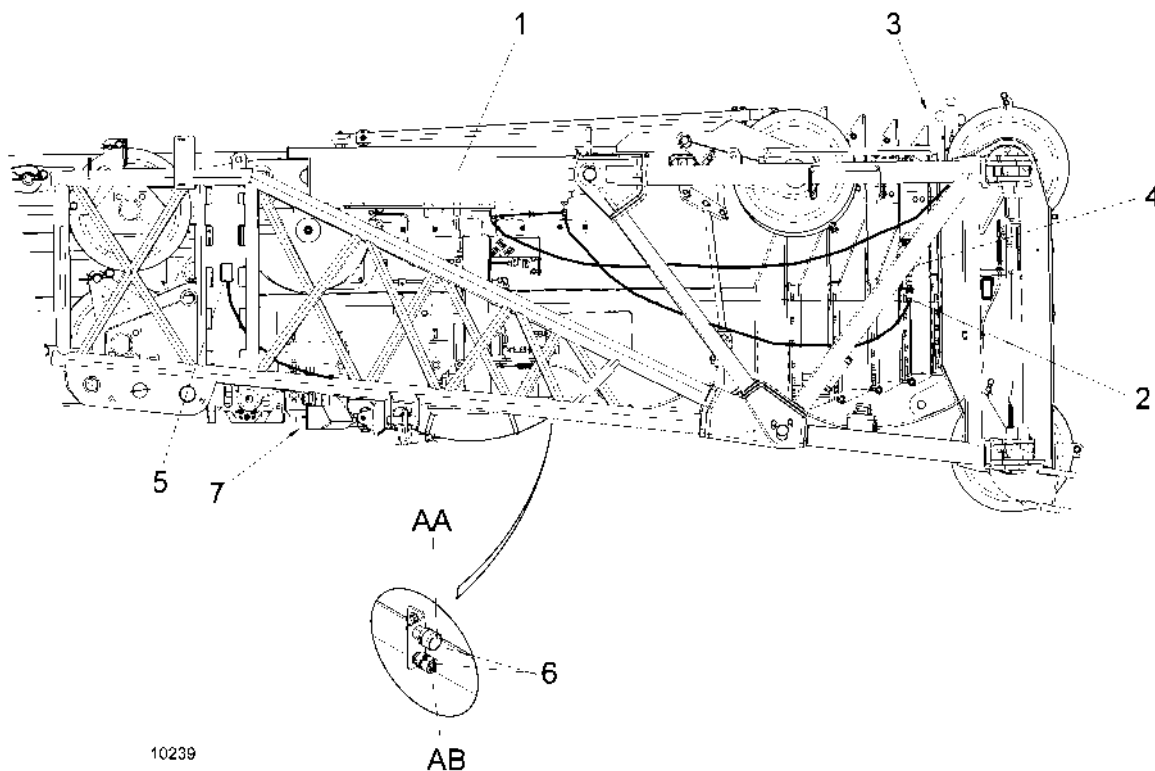

### NOTICE

#### Hydraulic lines not connected to the mobile crane!

Temperature fluctuations may cause pressure fluctuations in the hydraulic cylinder, which may damage the hydraulic cylinder.

While the vehicle is being driven, the hydraulic lines must always be connected to the luffing jib on the mobile crane.



### NOTICE

#### Insufficient pressure in the hydraulic cylinder!

Before starting any journey or if the mobile crane has been out of use for long periods, check the pressure in the luffing jib pressure gauge and if necessary increase it to 100 bar (1,450.4 PSI). To do this, operate the "Luffing jib on" rocker switch and carefully operate the "Raise luffing jib" function on the crane control lever until the pressure gauge shows a pressure of more than 100 bar (1,450.4 PSI). The "Jib luffing cylinder not retracted" warning lamp must not light up as you do this.

#### Installing the fly jib on the mobile crane - transport position

The following section describes the installation of the 3-piece fly jib to the telescopic boom of the mobile crane.

	<b>! WARNING</b>
	<p><b>Risk of accident!</b> An incorrectly bolted jib may come off and fall on the ground. In the driving mode, all parts of the stinger must be locked and bolted together as well as bolted on the base boom.</p> <ol style="list-style-type: none"><li>1. Always ensure that all lock pins, retaining pins and swivel pins are in the prescribed positions.</li></ol>

#### Requirements

- The mobile crane is supported as prescribed.
- The slewing gear brake is engaged.
- All telescopes are retracted.
- The superstructure is slewed to the back or side.
- The telescopic boom is set horizontally ( $\pm 1^\circ$ ).

**! WARNING!** In case of larger angles, there is a risk of accident and personal injuries.

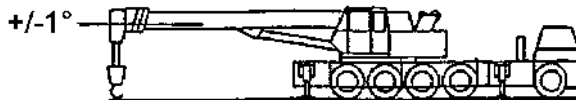



09412

- Parts of the stinger are corrected bolted with each other using lock pins.
- The double ladder, crank handle and the remote control for the slewing cylinder/locking cylinder are ready.

	<b>! WARNING</b>
	<p><b>Risk of skidding and accident!</b> When climbing and stepping on ladders and access ladders, take utmost care especially in case of humid weather.</p> <ol style="list-style-type: none"><li>1. Always keep the ladders and access ladders clean.</li><li>2. Remove dirt and other greasy substances immediately and thoroughly.</li><li>3. Always hold the ladder beams or handles while climbing up or down.</li><li>4. Wear non-slip shoes and keep them clean.</li><li>5. Ensure that the ladders are safe.</li></ol>

- The pressure gauge on the hydraulic cylinder shows more than 100 bar (1450.4 psi).

### Checking the hydraulic oil pressure in the hydraulic cylinder of the fly jib

	 <b>WARNING</b>
	<p><b>Insufficient pressure in the hydraulic cylinder!</b></p> <p>If the pressure in the hydraulic cylinder is too low, the jib may be unstable when it is raised. The fly jib may fold down in an uncontrolled manner.</p> <ol style="list-style-type: none"> <li>1. Every time the jib is to be lifted, you must first check that the pressure in the hydraulic cylinder is more than 100 bar (1450.4 psi).</li> <li>2. If the pressure shown is less than 100 bar (1450.4 psi), the jib must not be lifted.</li> </ol>

There is a pressure gauge under the hydraulic cylinder (1) for the hydraulically angled jib.



If the pressure gauge shows a pressure of more than 100 bar (1450.4 psi), the jib can be raised. If the pressure gauge shows a pressure of less than 100 bar (1450.4 psi), the pressure must be increased.

To build up the pressure in the hydraulic cylinder, proceed as follows:

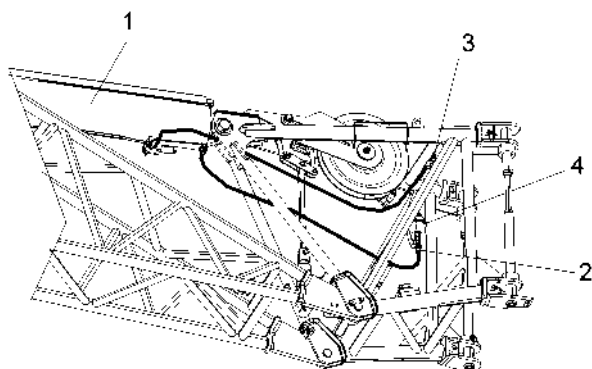

10208

1. Remove the hydraulic lines from the storage position (2) on the expansion tank (4) or from the clamp-fitted buffer (3).

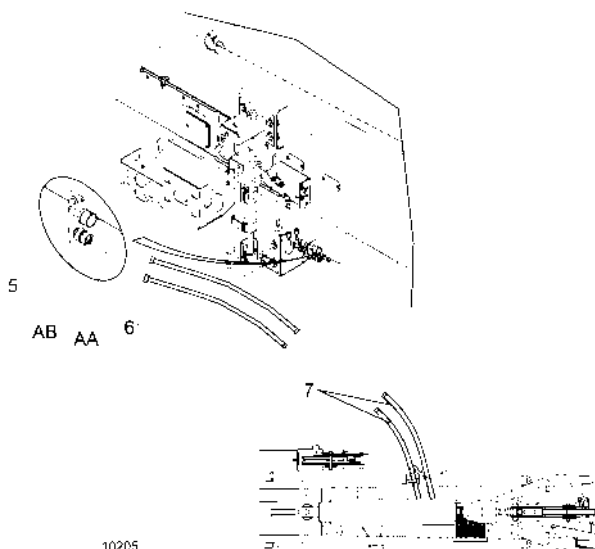

10205

2. Connect suitable extension lines (6) to the ports (5) on the telescopic boom and on the jib (7).  
Observe the following order for connecting to the telescopic boom:
  - 1. Connect line (AB) for the luff down function.
  - 2. Connect line (AA) for the luff up function.
 Extension lines can be purchased from TADANO.
3. Switch on the battery main switch and the ignition in the crane cab. Start the superstructure engine.
4. Operate the "Activate jib luffing" rocker switch, then carefully operated the "Raise luffing jib" function until the pressure gauge shows a pressure of more than 100 bar (1450.4 psi).
5. Switch off the superstructure engine.
6. Disconnect the hydraulic lines first from port (5) on the telescopic boom. Observe the following order when disconnecting:
  - 1. Disconnect line (AA) for the luff up function.
  - 2. Disconnect line (AB) for the luff down function.
7. Connect lines (7) to port (2) of the expansion tank (4) and in clamp-fitted buffer (3).

For information about the crane control lever, see the Functions of the control lever and pedals section.

### Preparing the transporting support

1. Fix the guide belt on the head of the 6.0-m-stinger foot (19.7 ft).

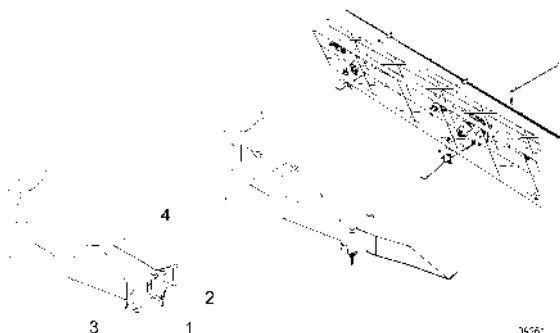

2. Fold out the middle transporting support. Remove the folding plug (1) and pull the bolt (2) downwards. Fold out the transporting support extension (4), insert the bolt (2) in the hole (3) from bottom and secure using the folding plug (1).

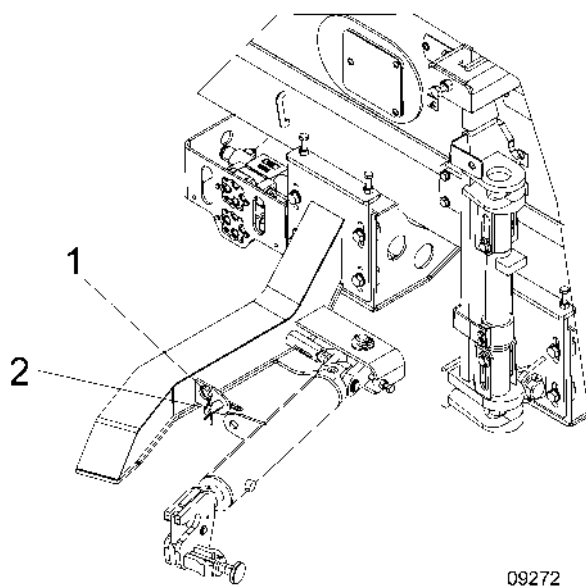

3. Loosen the pin between the slewing cylinder and the transporting support. Pull the spring clip (1) and bolt (2) for this. Press the slewing cylinder to the right. Re-insert the bolt (2) into the hole of the transporting support and secure using the spring clip (1).

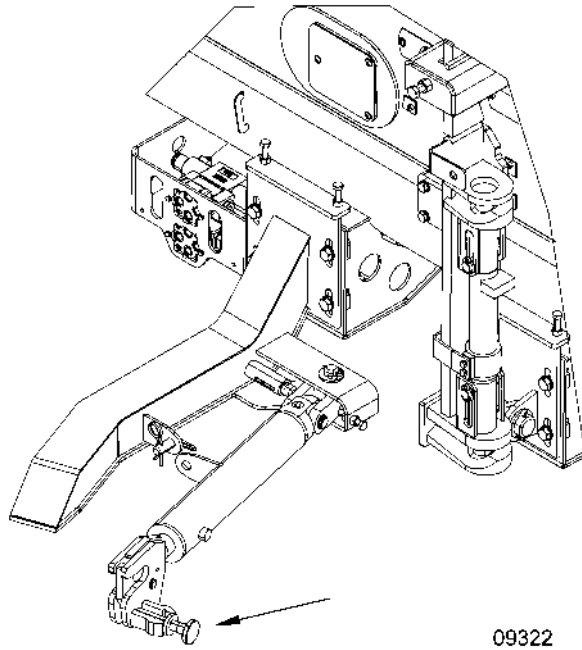

4. Pull the lock on the slewing cylinder until the hook lock opens.
5. Connect the remote control.
6. Start the superstructure engine.
7. Activate the  setup mode in the automatic safe load indicator.

#### Bolting one side of the fly jib to the boom head

1. Lift the 18-m-fly jib (59.1 ft) with the roller carrier using the auxiliary crane.  
Use suitable slinging aids, see *Sling points on fly jib [page 316]*.

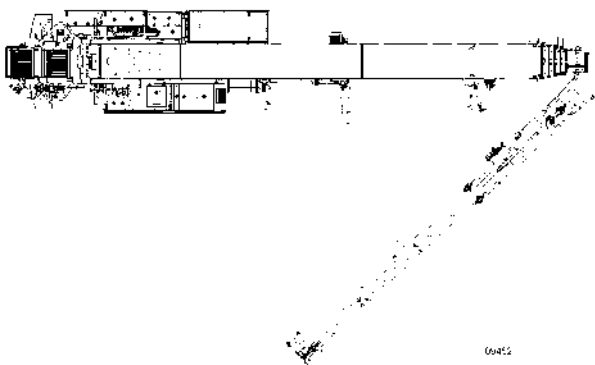

2. Adjust the fly jib on the telescopic boom so that the holes of the 3.8-m-fly jib (12.5 ft) are aligned on the right side of the boom head.



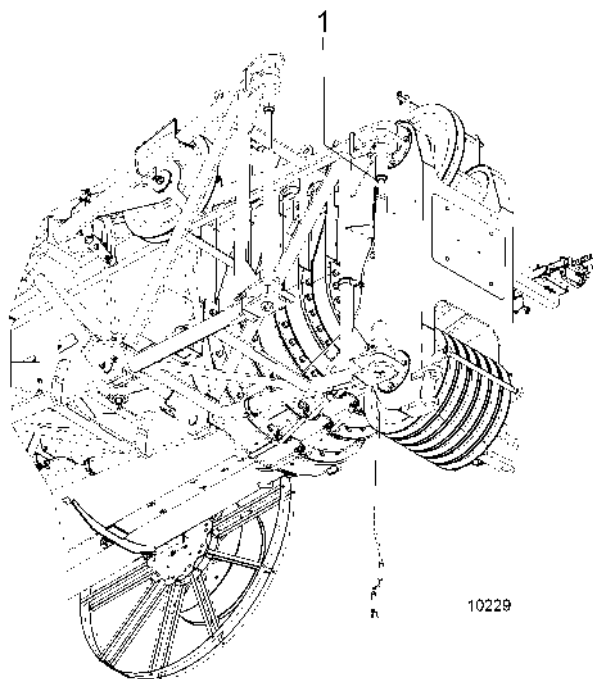

3. Insert the crank handle into the threaded bolt and turn until the third red marking (1) is completely visible. **⚠️ WARNING! The upper and lower bolt elements must be retracted completely (up to the end stop) in the bearing brackets on the boom head. Since both bolt ends are not retracted completely, the stinger may fall!**
4. Remove the crank handle again.
5. Detach the sling gear from the lifting eyes of the fly jib.

#### Connecting the fly jib with the locking cylinder

1. Extend the slewing cylinder completely using the remote control (the right lever to the front).

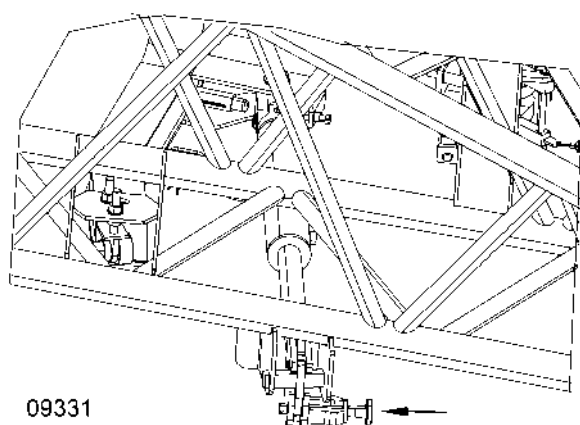

2. Slew back the stinger using the guide belt until it engages in the lock of the slewing cylinder.

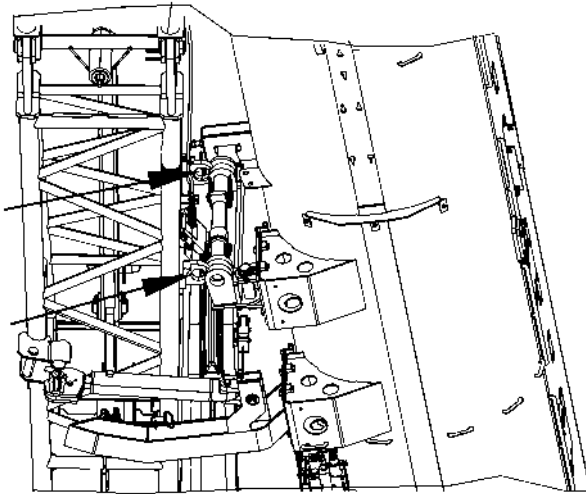

09324

3. Retract the slewing cylinder using the remote control (the right lever to the back) until the holes on the locking cylinder align with the holes on the 3.8-m-fly jib (12.5 ft).
4. Pin the stinger with the telescopic boom. Extend the locking bolts using the remote control (the left lever to the front). **⚠️ WARNING! The locking cylinder must be extended completely. If the locking cylinder is not fully extended, the fly jib may fall.**



5. Check whether the locking cylinder is extended completely. The height of the tip of the indicator arrow (1) and the tip of the red marking (2) must be the same.

### Releasing the fly jib from the boom head

1. Release the slewing cylinder. Extend the slewing cylinder by 1 to 2 mm (0.039-0.078 in) using the remote control (the right lever to the front).

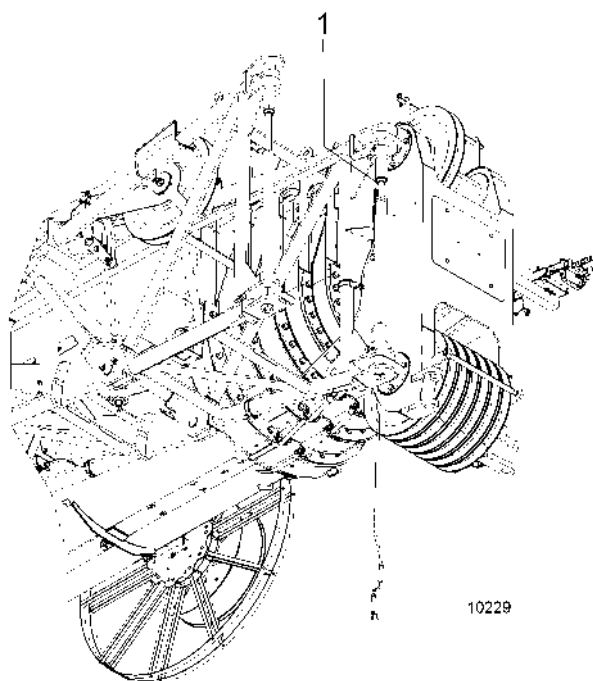

2. Loosen the pin on the right side of the boom head. Insert the crank handle into the threaded bolt and turn it up to the end stop. **NOTICE! The upper and lower bolt elements must be extended from the holes of bearing brackets on the boom head.**
  - ⇒ The safety flap (2) is fixed on the locking cylinder.

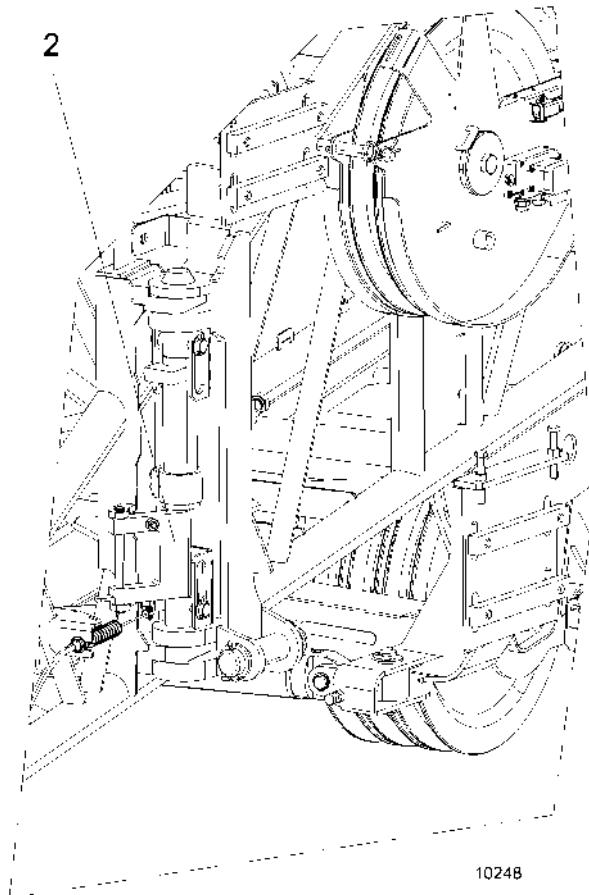

3. Remove the crank handle again.
4. Retract the slewing cylinder up to the end stop using the remote control (the right lever to the back).

### Pin the fly jib on the telescopic boom

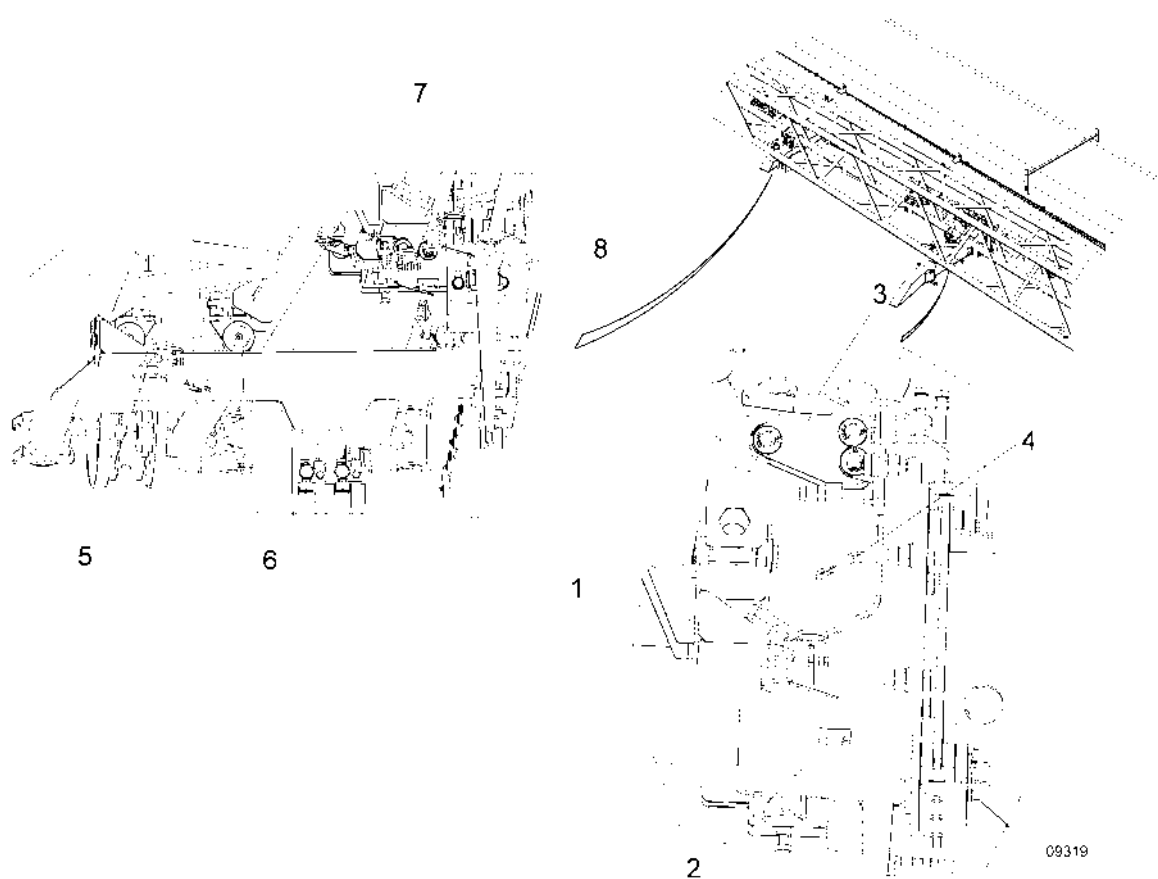

1. Fix the pins (1) and (3) on the **middle** transporting support.  
 Pull the lock pin from the pin compartment (2), insert it into the hole (1) and secure it again using the spring clip.  
 Pull the lock pin from the pin compartment (4), insert it into the hole (3) and secure it again using the spring clip.
2. Fix the pins (5) and (7) on the **rear** transporting support.  
 Pull the lock pin from the pin compartment (6), insert it into the hole (5) and secure it again using the spring clip.  
 Pull the lock pin from the pin compartment (8), insert it into the hole (7) and secure it again using the spring clip.
3. Switch off the engine and the ignition.
4. Detach the remote control.
5. Remove the guide belt.
6. Fold back the middle transporting support, pin and secure it.

### Connecting the hydraulic and electrical lines

1. Remove the hydraulic lines on the hydraulic cylinder (1) from the storage position (2) on the expansion tank (4) and from the clamp-fitted buffer (3) and connect them to the appropriate ports (6) on the telescopic boom. Observe the following order when connecting:

- ⇒ 1. Connect line (AB) for the luff down function.
- ⇒ 2. Connect line (AA) for the luff up function.

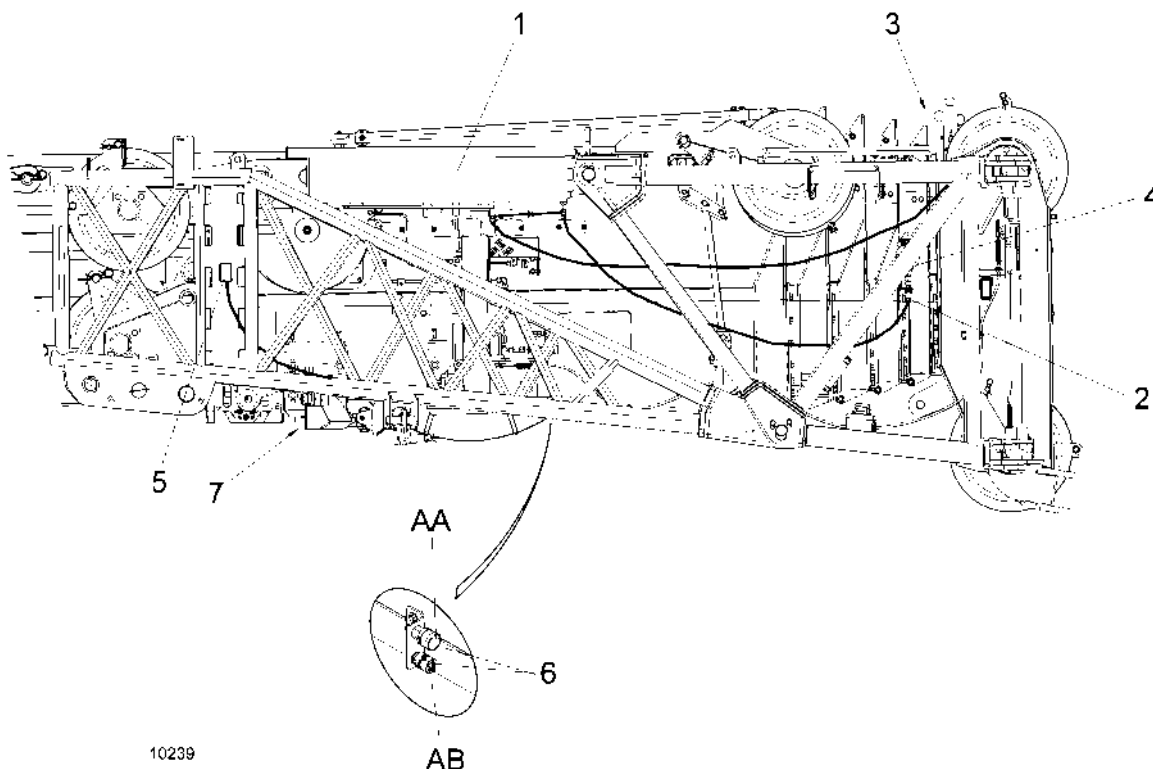

- 2. Remove the electrical line for the "Jib, luffing cylinder not retracted" display from the dummy connector housing (5) on the boom foot and connect it to the telescopic boom (7).

#### Detaching the fly jib

The fly jib is detached in the reverse order, during which the pressure gauge on the hydraulic cylinder must show more than 100 bar (1450.4 psi).

	<p><b>⚠ WARNING</b></p>
	<p><b>Insufficient pressure in the hydraulic cylinder!</b></p> <p>If the pressure in the hydraulic cylinder is too low, the jib may be unstable when it is raised. The fly jib may fold down in an uncontrolled manner.</p> <ol style="list-style-type: none"> <li>1. Every time the jib is to be lifted, you must first check that the pressure in the hydraulic cylinder is more than 100 bar (1450.4 psi).</li> <li>2. If the pressure shown is less than 100 bar (1450.4 psi), the jib must not be lifted.</li> </ol>



### NOTICE

#### Fly jib set down incorrectly!

If the fly jib is set down on dirty ground or too quickly, it may be damaged.

1. Once it has been detached, always place the fly jib on timbers or trestles with sufficient load-bearing capacity.
2. Set the fly jib down slowly and carefully.

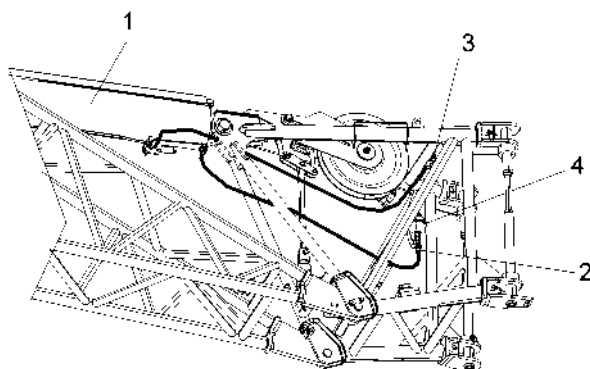

10208





### NOTICE

#### Fluid escaping from the expansion tank!

When the luffing jib is removed, temperature fluctuations may cause pressure fluctuations in the hydraulic cylinder (1). This may cause hydraulic fluid to escape.

1. Make sure that the hose lines from the hydraulic cylinder (1) are connected to the expansion tank (4) and stored in the clamp-fitted buffer (3).
2. When the luffing jib is removed, make sure that the expansion tank (4) is checked and any escaped fluid emptied on a daily basis. Excess fluid must be emptied into a suitable container.

## 3.10.3 Lifting work

	 <b>WARNING</b>
	<p><b>Loads not slung correctly!</b></p> <p>If the load is not slung correctly, it may come off and fall on the ground. When lifting multiple loads simultaneously, their equilibrium may be affected and they may fall on the ground. Risk of accident!</p> <ol style="list-style-type: none"> <li>1. Load slung correctly.</li> <li>2. Always sling only one load.</li> <li>3. Follow the following points.</li> </ol>

As a rule, ropes may not be loaded beyond their maximum permissible load.

When slinging the ropes, an opening angle of  $120^\circ$  may not be exceeded (the opening angle is the angle between the ropes). The inclination angle is  $60^\circ$  in this case.

At an inclination angle of  $60^\circ$ , the traction force in slinging ropes doubles. In such a case, the ropes must be dimensioned for the double load.

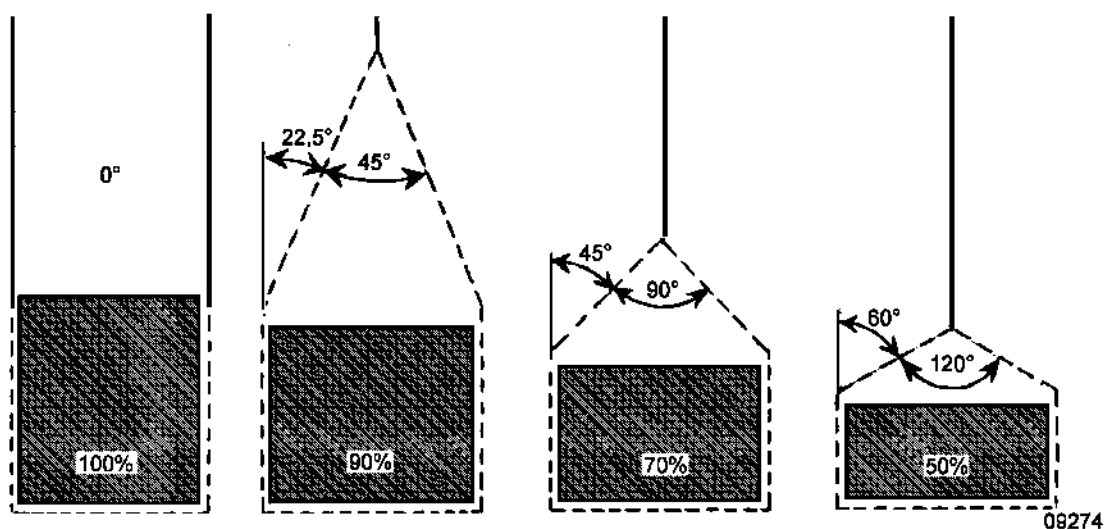

Check the ropes for wear, breakages and strand breakage. Check the rope lock fastener.

Never use old or shortened load ropes as slinging ropes.

In case of sharp-edged loads, attach suitable pads such as wood to prevent the slinging ropes and the load from damaging.



End joints of ropes must comply with the intended use.

Wire ropes may not be knotted.

The legal regulations for the area of application must be adhered to.



## Fixing the hoisting rope

	 <b>WARNING</b>
	<p><b>The hoisting rope is overloaded!</b></p> <p>If the hoisting rope is used excessively less rope falls, it may break. The load may fall. Risk of accident!</p> <p>1. Select the number of rope falls such that the permissible load for the hoisting rope is not exceeded. Refer to the technical data for permissible values.</p>

## Reeving

Outrig the mobile crane.

Slew the main boom and/or the jib such that the crane can be operated easily.

Lower the main boom and/or the jib to the maximum possible extent.

Place the bottom block on the ground.

Remove the anti-twoblock device weight from the hoisting rope.

Remove the securing clamp from the head of the boom or the jib.

Remove the linch pin. Fold down the covers of the bottom block.

Reeve the hoisting rope as described in "Hoisting rope reeving examples".

	<p>If the hoisting rope needs to be unwound, it should be pulled manually and the winch must be actuated simultaneously.</p>
---	--

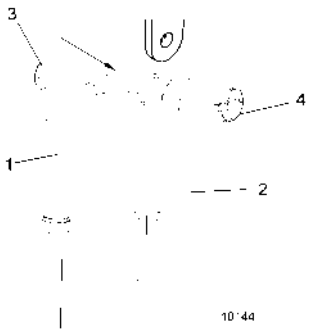
	<p>The basic model of the mobile crane is equipped with a hoisting rope with a steel rope clip (1) and a rope clamp (2).</p> <p>In case of the even number of rope falls, the rope clamp is fixed on the boom head, whereas it is fixed on the bottom block if this number is odd.</p> <p>The steel rope clip of the hoisting rope attached to the rope clamp as shown in the image. Insert the pin (3) in the arrow direction and pin it with the boom head or the bottom block to ensure that the steel rope clip no longer unhooks from the rope clamp. After inserting the pin in the arrow direction, secure it immediately using the folding plug (4).</p>
---	--

When installing a new rope clamp or a hoisting rope, use only original TADANO spare parts (see the specifications embossed on the rope clamp).

The number of rope falls depends on the load to be lifted.

The lifting or lowering speed of the bottom block decreases with increasing number of rope falls.



#### **WARNING**

##### **Lock pin mounted incorrectly!**

The folding plug (4) may come off the lock pin (3) can be lost. The rope socket may come off and the load may fall. Risk of accident!

1. The locking pin (3) must always be inserted in the arrow direction and secured using the folding plug (4).

#### **Fastening the rope clamp**

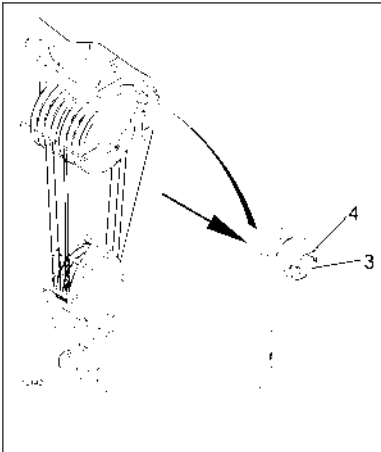

In case of the even number of rope falls/ropes on the boom head

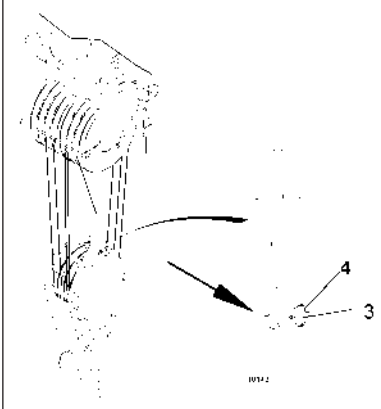

In case of the odd number of rope falls/ropes on the bottom block

## Attaching the anti-twoblock device weight

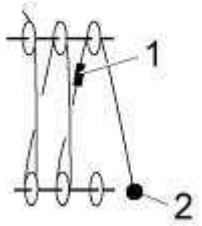
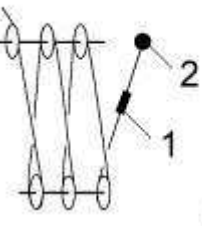
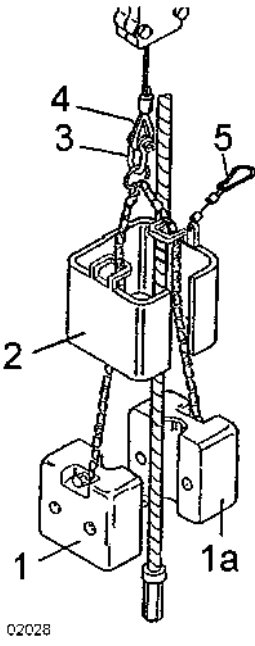
 <p>09276</p>	<p>In case of the odd number of rope falls/ropes, attach the release weight (1) on the pinned rope fall. 2 = hoisting rope fixing.</p>
 <p>09277</p>	<p>In case of the even number of rope falls/ropes, attach the release weight (1) on the last rope fall. 2 = hoisting rope fixing.</p>
 <p>02028</p>	<p>The anti-twoblock device weight comprises two sections (1 and 1a) with a retaining device (2) Fix the shackle (3) of the chain in the retaining thimble (4) of the anti-twoblock device. Place both sections of the release weight around the hoisting rope and fix them such that pins of one weight half can be inserted into the holes of the second weight half. Press the weights together and move the retaining device (2) over the release weight. Attach a snap hook (5) in the first chain link over the retaining device. Note: Fit country-specific chain extension.</p>

Attach the securing clamp on the head of the boom or the jib.

Fold up the covers of the bottom block. Attach the linch pin.

Ensure that the hoisting rope remains in the retaining sheave.

Raise until the hoisting rope becomes taut. Then wind the hoisting rope.

## Customary rope clamp type (rope end clamp)

	<p><b>! WARNING</b></p>
	<p><b>The rope clamp is subjected to shock-type loads!</b> The hoisting rope may break from the rope clamp. The load may fall.</p> <p>1. Avoid shock-type loads before the final wedge fit.</p>

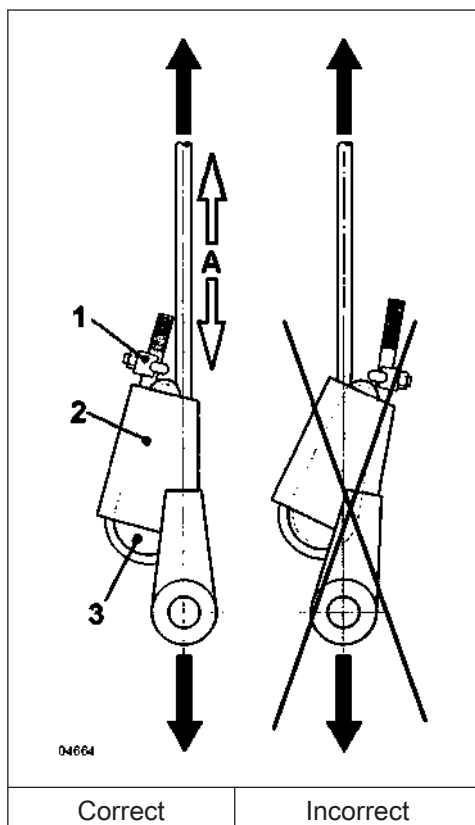

The rope socket of the customary rope clamp is attached as follows:

Fix the rope end to the bottom block (in case of the odd number of rope falls) or the boom head (in case of the even number of rope falls) using a rope clamp.

Since the rope clamp (2) is a connection that is safely closed only under a tensile stress, the free end of the rope must be secured against pulling even in case of a self-inhibiting rope wedge (3).

Observe the following important instructions:

Always insert the hoisting rope such that the pulling rope runs along the pulling axis of the rope clamp (A).

If the hoisting rope is inserted incorrectly, it will kink, break and wear out early.

The free end of the rope must be secured using a rope clamp (1).

Do not use any devices for securing if they connect the free end of the rope to the carrying rope fall such that forces can be transferred.

After pinning the rope clamp on the boom head or the bottom block, increase the load gradually until the rope wedge reaches its end stop.

#### Hoisting rope reeving examples

Depending on the required lifting load, determine the bottom block and the required number of rope falls with the help of "Notes regarding the lifting capacity chart" and the lifting capacity charts.

Reeve the hoisting rope depending on the required number of rope falls as described below:

If possible, the reeving in the bottom block should be done such that the bottom block is suspended vertically especially in case of a small number of ropes (see the 4-line example).

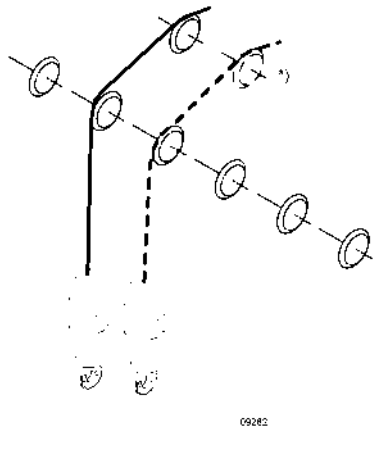
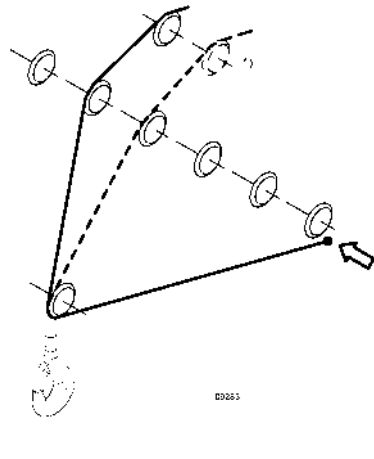
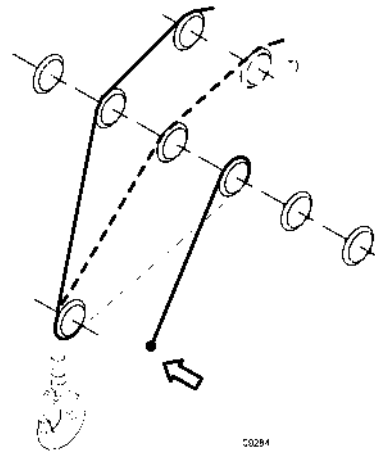
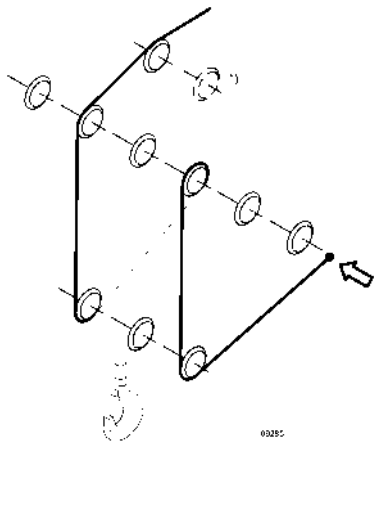
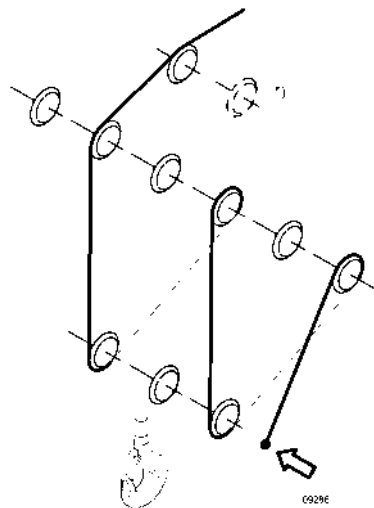
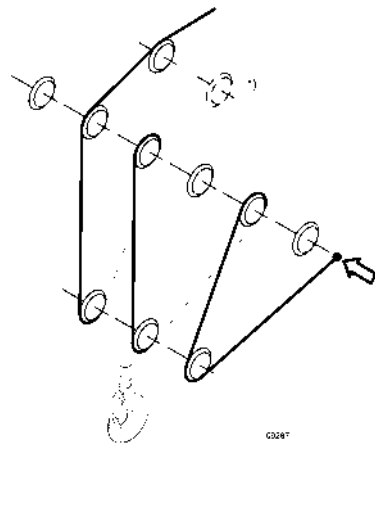
<b>Bottom block</b>	<b>Bottom block, 1-sheave,</b>	<b>Bottom block, 1-sheave</b>
1-line reeved	2-line reeved	3-line reeved
		
<b>Bottom block, 3-sheave</b>	<b>Bottom block, 3-sheave</b>	<b>Bottom block, 3-sheave</b>
4-line reeved	5-line reeved	6-line reeved
		

<p><b>Bottom block, 3-sheave</b></p>	<p><b>Bottom block, 5-sheave</b></p>	<p><b>Bottom block, 5-sheave</b></p>
<p>7-line reeved</p>	<p>8-line reeved</p>	<p>9-line reeved</p>
<p><b>Bottom block, 5-sheave</b></p>	<p><b>Bottom block, 5-sheave</b></p>	<p><b>Bottom block, 7-sheave</b></p>
<p>10-line reeved</p>	<p>11-line reeved</p>	<p>12-line reeved</p>

## 3.10.4 Hook tackle/bottom block

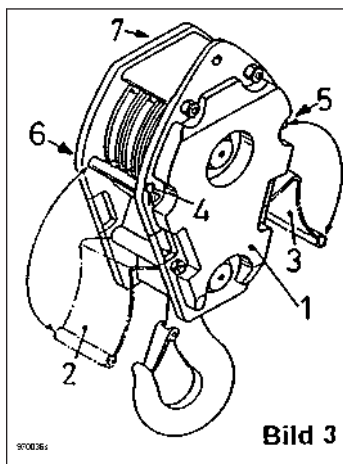

1. Remove the folding plugs (4 and 5).
2. Pull both the pins (6 and 7) from the bottom block (1).
3. Fold down the plates (2) and (3) from the side.
4. Place the hoisting rope. **NOTICE! The hoisting rope may not fall from the rope groove and clamp between the sheaves.**
5. Fold up the plates (2) and (3) again.
6. Insert the pins (6 and 7).
7. Attach the folding plugs (4 and 5).

## 3.10.5 Bottom block holder\*)

	<p style="text-align: center;"><b>! DANGER</b></p> <p><b>The bottom block may oscillate.</b> When storing or removing the bottom block from the bottom block holder, the bottom block may oscillate. This may damage the superstructure cabin. Persons located between the bottom block holder and the superstructure may get crushed.</p> <ol style="list-style-type: none"> <li>1. Inform the assistant personnel and point out the hazards.</li> <li>2. All lifting movements must be carried out slowly with utmost care.</li> <li>3. Assistant personnel should not be present between the bottom block holder and the superstructure cabin.</li> </ol>
	<p style="text-align: center;"><b>! CAUTION</b></p> <p><b>Risk of crushing!</b> There is a risk of crushing when storing or removing the bottom block from the bottom block holder.</p> <ol style="list-style-type: none"> <li>1. Inform the assistant personnel regarding the risk of crushing.</li> </ol>

	<b>⚠ WARNING</b>
	<p><b>Risk of skidding and accident!</b></p> <p>When climbing and stepping on ladders and access ladders, take utmost care especially in case of humid weather.</p> <ol style="list-style-type: none"><li>1. Always keep the ladders and access ladders clean.</li><li>2. Remove dirt and other greasy substances immediately and thoroughly.</li><li>3. Always hold the ladder beams or handles while climbing up or down.</li><li>4. Wear non-slip shoes and keep them clean.</li><li>5. Ensure that the ladders are safe.</li></ol>

**Prerequisites:**

- Assistant personnel are available.
- The mobile crane is supported as prescribed.
- All telescopes are retracted.
- The slewing gear brake is engaged.
- The superstructure is slewed sideways to the left so that the assistant personnel can safely stand on the carrier.
- Only the 25-t bottom block (1-sheave, 375 kg) or the 63-t bottom block (3-sheave, 600 kg) can be stored.





- The bottom block to be stored must be attached to the bottom block eyelet on the bottom block of the crane using suitable slinging aids.

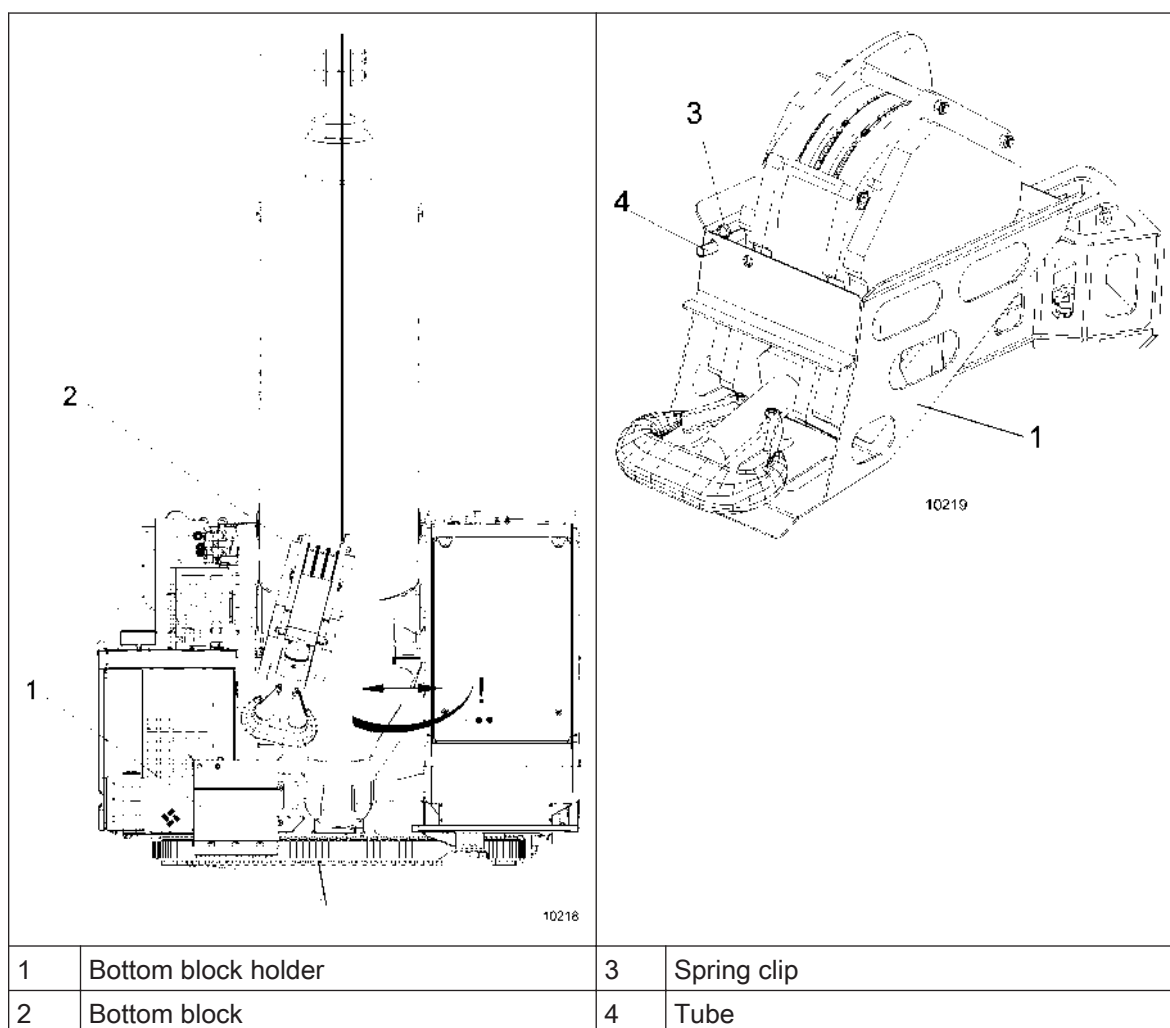



1. Assistant personnel can now climb on the crane using access steps.
  2. Remove the tube (4) from the bottom block holder. For this, pull the spring clip (3).
  3. Release the bottom block (2) slowly until the assistant personnel can hold the bottom block (2).
  4. Continue releasing the bottom block (2) slowly; the assistant personnel must keep the bottom block (2) in the bottom block holder (1) as shown.
  5. Insert the tube (4) again into the bottom block holder (1) as per the width of the bottom block (2).
  6. Secure the tube (4) using a spring clip (3).
  7. Secure the bottom block (2) in the bottom block holder (1) against slipping.
- Remove the bottom block logically in the reverse order.

### 3.10.6 Single top

	 <b>WARNING</b>
	<p><b>Crossing and scuffing of hoisting ropes!</b> Hoisting ropes may break. The load may fall. Risk of accident!</p> <ol style="list-style-type: none"> <li>1. When working with two hoisting ropes, guide the hoisting rope over sheaves as illustrated below.</li> </ol>

**i**

The single top is always operated 1-line.

#### Mounting the single top on the boom head

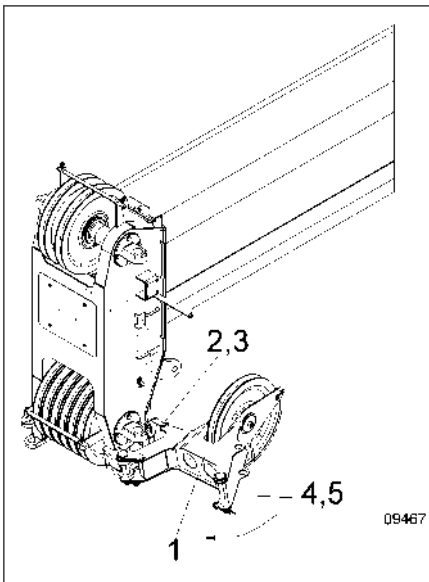

Remove the spring clip and pin (items 4, 5).  
Loosen the transport clamp, loosen the spring clip of the lock pin (items 2, 3) and remove the lock pin.

Slew the single top (item 1) up to the end stop

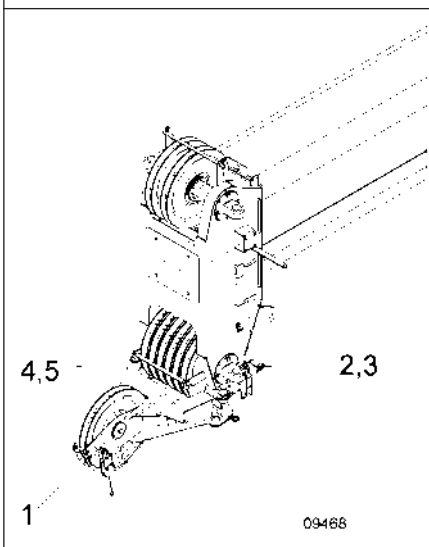

Mount the transport clamps (items 2, 3) again to ensure that they are not lost.

Fix the single top (item 1) on the boom head by inserting the pin (item 4).

Secure the pin (item 4) using the spring clip (item 5).

## Rope fall when operating with hoisting gear 1

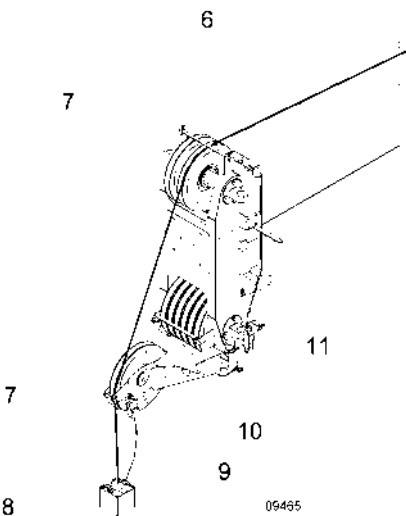
 <p>Diagram showing the assembly of hoisting gear 1. A hoisting rope (item 6) is shown being placed over a single top. A securing clamp (item 7) is mounted. The rope is guided through a release weight (item 8) and an anti-two-block device (item 9). An electrical plug is disconnected from a blind socket (item 10) and inserted into a plugbox (item 11). A blind plug is inserted into the blind socket (item 10) for safety. The diagram is labeled with part numbers 6, 7, 8, 9, 10, 11 and a reference number 09465.</p>	<p>Remove the securing clamp (7). Place the hoisting rope (item 6) over the single top. Mount the securing clamp (item 7) again. Guide the hoisting rope through the release weight (item 8) and fix the anti-two-block device (item 9). Disconnect the electrical plug from the blind socket (item 10) and insert it into the plugbox (item 11). Insert the blind plug into the blind socket (item 10) to keep it safe. After completing work, dismantle the single top in the logical reverse order.</p>
--	--

## Rope fall when operating with hoisting gears 1 and 2

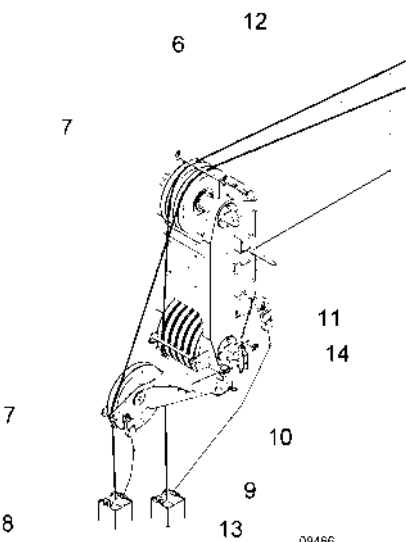
 <p>Diagram showing the assembly of hoisting gears 1 and 2. The hoisting rope of the 1st hoisting gear (item 6) is placed over the boom head and secured with a securing clamp (item 7). It is guided through a release weight (item 13) and an anti-two-block device (item 14). The hoisting rope of the 2nd hoisting gear (item 12) is placed over the single top and secured with a securing clamp (item 7). It is guided through a release weight (item 8) and an anti-two-block device (item 9). An electrical plug is disconnected from a blind socket (item 10) and inserted into a plugbox (item 11). A blind plug is inserted into the blind socket (item 10) for safety. The diagram is labeled with part numbers 6, 7, 8, 9, 10, 11, 12, 13, 14 and a reference number 09466.</p>	<p>Place the hoisting rope (item 6) of the 1st hoisting gear over the boom head and secure it using the securing clamp (item 7). Guide the hoisting rope of the 1st hoisting gear through the release weight (item 13) and fix the anti-two-block device (item 14). Place the hoisting rope (item 12) of the 2nd hoisting gear over the single top and secure it using the securing clamp (item 7). Guide the hoisting rope of the 2nd hoisting gear through the release weight (item 8) and fix the anti-two-block device (item 9). Disconnect the electrical plug from the blind socket (item 10) and insert it into the plugbox (item 11). Insert the blind plug into the blind socket (item 10) to keep it safe. After completing work, dismantle the single top in the logical reverse order.</p>
--	--

## 3.10.7 Removing the second hoisting gear, mounting the balancing counterweight

	<p><b>! WARNING</b></p> <p><b>Crane operation without the second hoisting gear and the balancing counterweight!</b></p> <p>The 2nd winch is part of the counterweight. The mobile crane may become unstable and overturn if this is missing.</p> <ol style="list-style-type: none"> <li>1. If the 2nd winch is removed, operating the crane without mounting the 1.5-t (3307.5 lbs) balancing counterweight is prohibited.</li> <li>2. On-road travel is allowed only if the 2nd winch or the 1.5-t (3307.5 lbs) balancing counterweight is mounted.</li> </ol>
---	---

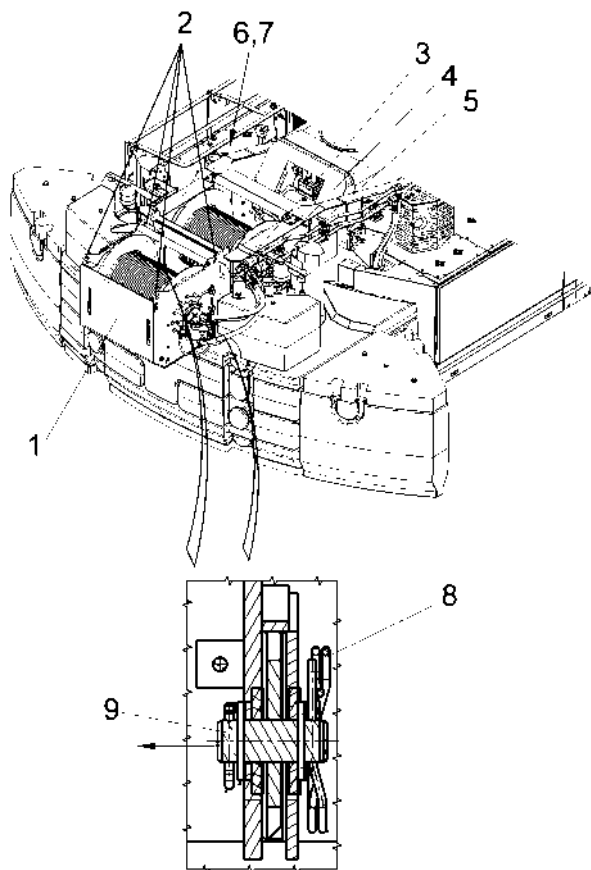

00525

The second hoisting gear is removed in the following steps:

1. Sling the second hoisting gear (1) on the attaching points (2) using suitable slinging aids.
2. Loosen the hydraulic quick-locking couplings (3, 4 and 5). Use suitable aids to collect the hydraulic oil that may drain. Fix the caps.
3. Disconnect the electrical plug (6).
4. Disconnect the plug of the central lubricating system (7).
5. Remove the right and left spring clips (8).
6. Remove the right and left pins (9). Pay attention to washers!
7. Push the second hoisting gear (1) upwards.

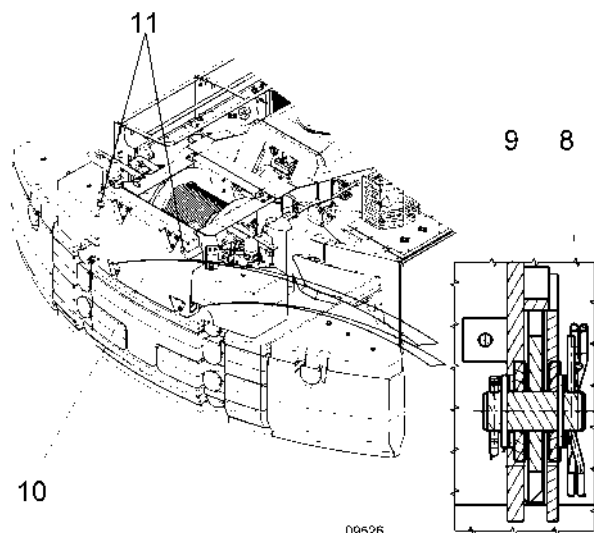

The balancing counterweight is mounted in the following steps:

1. Sling the balancing counterweight (10) on the attaching points (11) using suitable slinging aids.
2. Attach the balancing counterweight (10) in place of the second hoisting gear.
3. Attach the right and left pins (9). Pay attention to washers!
4. Attach the right and left spring clips (8).

Remove the balancing counterweight and the mount the auxiliary winch in the logical reverse order.

### 3.10.8 Two-hook operation

<b>i</b>	<p>The following specifications are applicable for operating with the hoisting gear over the boom head and the 2nd hoisting gear over a jib.</p> <p>If two hoisting gears are available, the use of jib and single top socket provides the option of placing the correspondingly positioned loads accurately or using loads.</p>
----------	--

Prerequisite:

The jib or the single top has been mounted on the telescopic boom head as prescribed. The mobile crane is supported as prescribed.

	<b>! WARNING</b>
	<p><b>Lifting or releasing with the incorrect hoisting gear!</b></p> <p>Components may be overloaded and may break. The load may fall. Risk of accident!</p> <ol style="list-style-type: none"> <li>1. A load must always be lifted or released with the component having the least loading capacity.</li> <li>2. The load must always be lifted or released completely.</li> </ol>



**! WARNING**

**Incorrect entry in the automatic safe load indicator!**

Components may be overloaded. The mobile crane may be overloaded and may overturn. Risk of accident!

1. The values to be entered in the automatic safe load indicator must match the configuration of the jib as well as the counterweight and the outrigger base. Always enter the actual number of ropes available on the jib.

The load ratings of the jib permissible for this case correspond to the maximum load ratings specified in the respective lifting capacity charts for the jib. The total load including the bottom block and all slinging aids may not exceed the specified load ratings for the setup condition of the mobile crane.



**! WARNING**

**Incorrect rope fall!**

Incorrect rope fall may lead to the failure of the hoisting gear or the hoisting rope on the telescopic boom head.

1. The reeving on the telescope boom head should never be less than the reeving of the jib. It must always be either equal to or greater than the reeving on the jib.



**! WARNING**

**Crossing and scuffing of hoisting ropes!**



Hoisting ropes may break. The load may fall. Risk of accident!

1. When working with two hoisting ropes, guide the hoisting rope over the sheaves such that crossing and scuffing are not possible.

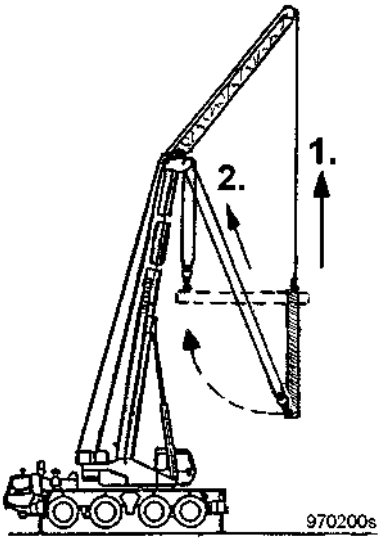
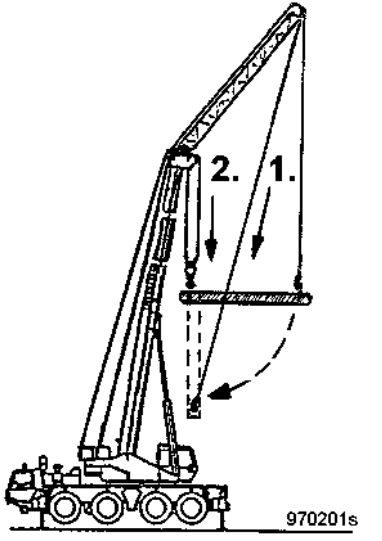

	<p><b>! WARNING</b></p>
	<p><b>Incorrect operation in the 2-hook mode!</b>                  Components may be overloaded. The mobile crane could turn over.                  Risk of accident!</p> <ol style="list-style-type: none"> <li>1. As a rule, every load must be lifted freely from the ground using the bottom block having the largest horizontal distance from the rotation centre.</li> <li>2. If the bottom block on the telescope boom head is loaded in case of a lifted load, the load display of the automatic safe load indicator displays an incorrect value.</li> <li>3. The telescopic boom should never be lowered when load is attached to both of the bottom blocks.</li> <li>4. Execute the crane work with utmost care.</li> </ol>

 <p style="text-align: right; font-size: small;">970200s</p>	<p>⇄</p>	 <p style="text-align: right; font-size: small;">970201s</p>
<ol style="list-style-type: none"> <li>1. Freely lift the load using the 2nd hoisting gear.</li> <li>2. Lift the load using the 1st hoisting gear.</li> </ol>		<ol style="list-style-type: none"> <li>1. Release the load using the 2nd hoisting gear.</li> <li>2. Stow the load using the 2nd hoisting gear.</li> </ol>

### 3.11 Crane operation with load

	 <b>WARNING</b>
	<p><b>Operating the crane without familiarizing adequately with mobile crane!</b> Incorrect operations may cause accidents that may lead to material damage and/or personal injuries.</p> <ol style="list-style-type: none"><li>1. The crane operator may work on the superstructure only after reading the previous chapters and after familiarizing himself/herself with the operating elements, safety instructions and warning devices.</li><li>2. The operator must especially observe all the following notes regarding different operating states and the "Notes regarding lifting capacity charts".</li><li>3. The mobile crane must be checked for its operational safety before every crane operation.</li><li>4. Observe the safety instructions.</li></ol>

#### 3.11.1 Influence of the temperature difference in case of heating of the boom due to solar radiation

	 <b>WARNING</b>
	<p><b>Boom overloaded!</b> The mobile crane may become unstable and overturn.</p> <ol style="list-style-type: none"><li>1. If the maximum angular load on the long telescopic boom or the jib is to be utilized completely, the lateral deformation of the boom must be checked visually before lifting the load.</li></ol>



In case of long-term solar radiation acting on one side of the telescopic boom, there is a temperature difference between the sun-side and the shadow-side of the boom. This temperature difference between the two sides of the boom leads to bending or lateral deformation of the boom owing to different thermal expansions.

A lateral deformation, if any, caused due to solar radiation may lead to the failure of the boom owing to the developed stresses.

Before lifting the load, the mobile crane must therefore be turned towards the sun such that both sides of the boom have approximately the same temperature to ensure that there is no lateral deformation owing to a temperature difference.



### 3.11.2 Crane operation on outriggers

	 <b>WARNING</b>
	<p><b>Crane control lever improperly actuated.</b> Very fast lifting, derricking, turning and braking movements can lead to the load swinging.</p> <ol style="list-style-type: none"> <li>1. The larger the load or the greater the boom length, the more careful the movements should be.</li> <li>2. Execute the crane work with utmost care.</li> </ol>

Check the ground conditions.

Lock the suspension and support the mobile crane such that it is in the horizontal position as prescribed (follow the spirit levels). Raise the tires completely off the ground.

When extending the outrigger beams to the half outrigger base, the applicable lifting capacity chart must be used and the correct values must be entered in the automatic safe load indicator.

The weight of the load to be lifted must be determined.

The bottom block and rope falls must be dimensioned adequately.

The permissible values given in the lifting capacity chart must be adhered to.

Weights of the bottom block, slinging ropes, cross beams, etc. must be deducted from the lifting capacity.

The selected lifting capacity chart must be exactly identical to the desired working state.

The wind speed may not overshoot the values specified in the notes regarding the lifting capacity chart.

The wind contact surface may not overshoot the values specified in the notes regarding the lifting capacity chart.

The maximum permissible load may not be exceeded.

Crane movements (speeds) must be selected such that jerk-free operations are possible.

Dragging is not allowed.

The load may be lifted and derricked only in the range of permissible values specified in lifting capacity charts.

The instruments, warning, indicator and pilot lamps as well as the display of the automatic safe load indicator must be monitored when operating the crane.

The crane must always be operated with the minimum possible working radius.

Check whether the jib has been mounted correctly and the program of the automatic safe load indicator is set to the required setup condition.

#### Overriding outrigger length sensor \*)

If the outrigger length sensor is defective, the outrigger base must be entered manually. The outrigger length sensors must be overridden with the "outrigger length sensor override" key-operated switch.

	<p>After completing the crane work, have the outrigger length sensor repaired by the nearest TADANO representative or the nearest TADANO dealer.</p>
---	--

#### Activating the override



1	Warning lamp for length sensor overridden	2	Key-operated switch for overriding outrigger length sensor
---	---	---	--

1. Turn the "override outrigger length sensor" clockwise.
  - ⇒ The "length sensor overridden" warning lamp lights up.
  - ⇒ The outrigger length sensors are overridden and the outrigger base must be entered manually.

#### Entering outrigger base manually

The outrigger base must be entered manually in the automatic safe load indicator, see *Entering the operating conditions [page 105]*.

## Deactivating the override



1 Warning lamp for length sensor overridden	2 Key-operated switch for overriding outrigger length sensor
---	--



1. Turn the "override outrigger length sensor" anticlockwise.
  - ⇒ The "length sensor overridden" warning lamp goes out.
  - ⇒ The outrigger length sensors are not overridden.

<b>i</b>	As long as the fault is not remedied, the mobile crane is not ready for operation.
----------	--

## 3.11.3 Crane operations on wheels

Not allowed (see instructions regarding the load bearing tables)

### 3.12 Ladders, access steps, railing

	<p><b>⚠ WARNING</b></p> <p><b>Risk of skidding and accident!</b> When climbing and stepping on ladders and access ladders, take utmost care especially in case of humid weather.</p> <ol style="list-style-type: none"> <li>1. Always keep the ladders and access ladders clean.</li> <li>2. Remove dirt and other greasy substances immediately and thoroughly.</li> <li>3. Always hold the ladder beams or handles while climbing up or down.</li> <li>4. Wear non-slip shoes and keep them clean.</li> <li>5. Ensure that the ladders are safe.</li> </ol>
	<p><b>⚠ WARNING</b></p> <p><b>Access steps and platforms not used!</b> If the provided devices are not used when working on the superstructure, there is a risk of the superstructure overturning.</p> <ol style="list-style-type: none"> <li>1. Use the provided access step to climb on the superstructure.</li> <li>2. Fold out the railing in the working position when working on the superstructure.</li> </ol>
	<p><b>⚠ WARNING</b></p> <p><b>The railing is not folded in the driving position in the driving mode!</b> If the railing the not folded in driving position during the driving mode, it may lead to collisions when driving over bridges or overpasses. It may lead to material damage and/or personal injuries.</p> <ol style="list-style-type: none"> <li>1. The railing must be folded in the driving position during the driving mode.</li> </ol>

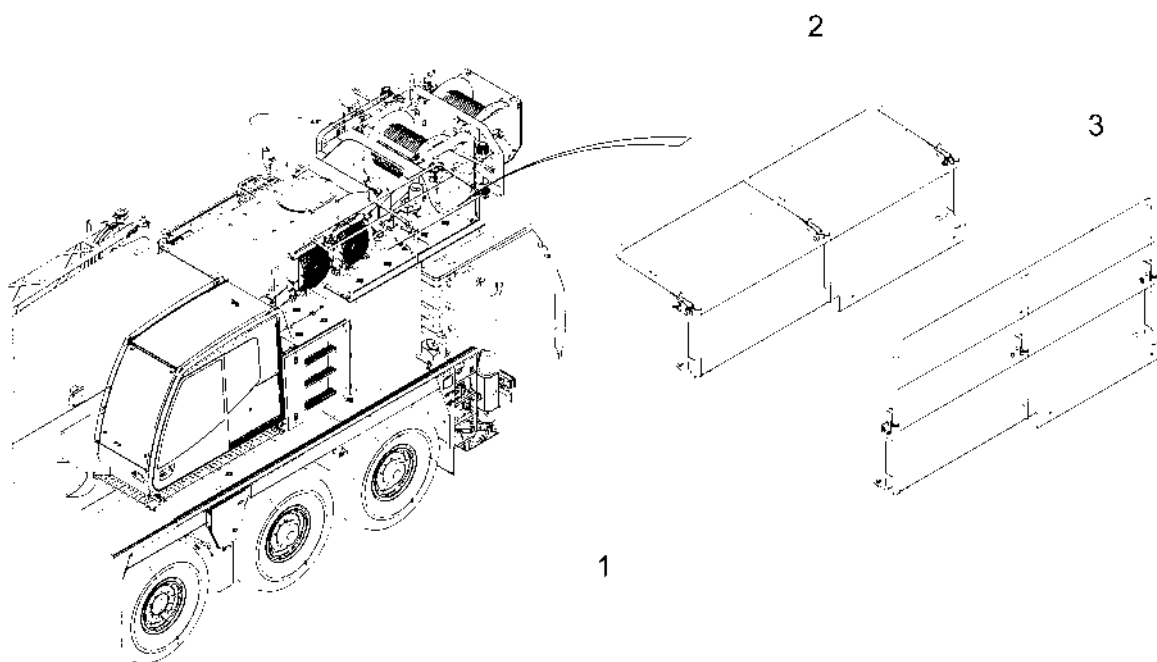



09445

1	Access step	3	Railing folded out (working position)
2	Railing folded (driving position)		

### 3.12.1 Double ladder

A stepladder is provided with the mobile crane for carrying out mounting and maintenance activities on the jib. The ladder is provided under the driver's cab.

	 <b>DANGER</b>
	<p><b>Risk of falling!</b> Improperly attached ladders and their improper use may pose the risk of falling.</p> <ol style="list-style-type: none"> <li>1. Place the ladder only on the plane and non-slippery surface having adequate load-bearing capacity.</li> <li>2. Check the stability.</li> <li>3. Follow the accident prevention regulations when using ladders and access steps.</li> </ol>

#### Removing the stepladder

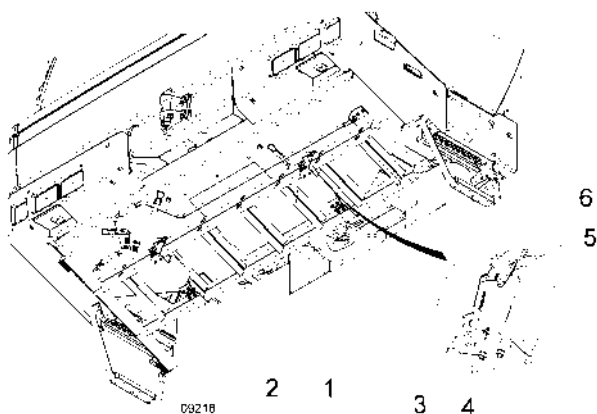

1	Angle bracket	4	Spring latch
2	Turnbuckle	5	Turnbuckle eye
3	Lock tab	6	Locating cramp

Removing the stepladder:

1. Remove the padlock.
2. Turn the lock tab upwards by 180°.
3. Press the spring latch up.
4. Release the turnbuckle eye and lower the bracket.
5. Open the second turnbuckle.
6. Remove the stepladder.

#### Stowing and securing the stepladder



#### **WARNING**

##### **Risk of accident!**

If ladders come off when driving, they may result in serious accidents.

1. Check the ladders for secure fastening and firmness.

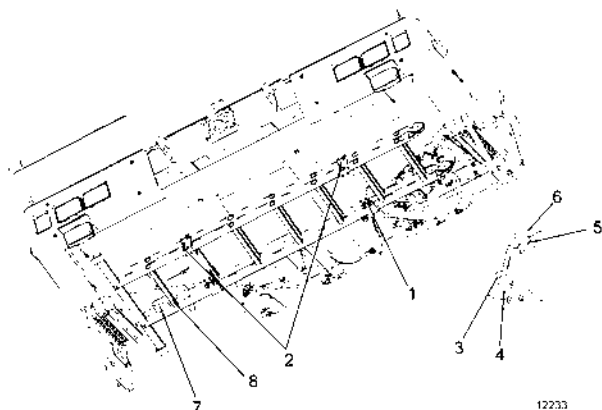

1	Angle bracket	5	Turnbuckle eye
2	Turnbuckle	6	Locating cramp
3	Lock tab	7	Retaining plate
4	Spring latch	8	Top rung

Stowing the stepladder:

1. Fold up the stepladder.
2. Mount the retaining plate on the top rung of the stepladder.  
**NOTICE! The retaining plate must face onwards.**
3. Push the ladder into the rear part of the angle brackets.  
**NOTICE! The bars on the movable part of the brackets must rest against one of the ladder's rungs in order to secure the ladder against shifting to the side.**
4. Attach the turnbuckle eye at the top in the locating cramp.
5. Press the spring latch down
6. Turn the lock tab downwards by 180°.
7. Close and secure the second turnbuckle.
8. Attach the provided padlock into one of the two catch levers and lock it.

### Fixing the ladders

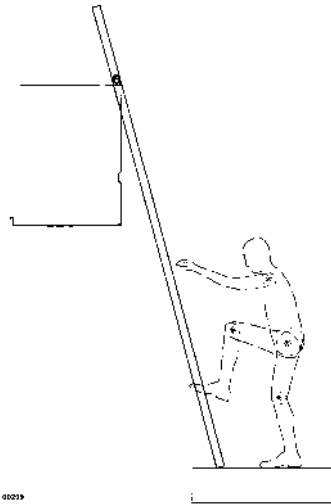
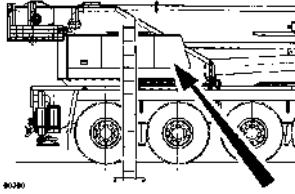

1. Fold out the ladders completely and rest at a suitable position. Remove and stow away the ladders in the logical reverse order.



### 3.13 Add-on parts, special and ancillary equipment

#### 3.13.1 Hourmeter for hoisting gear 1

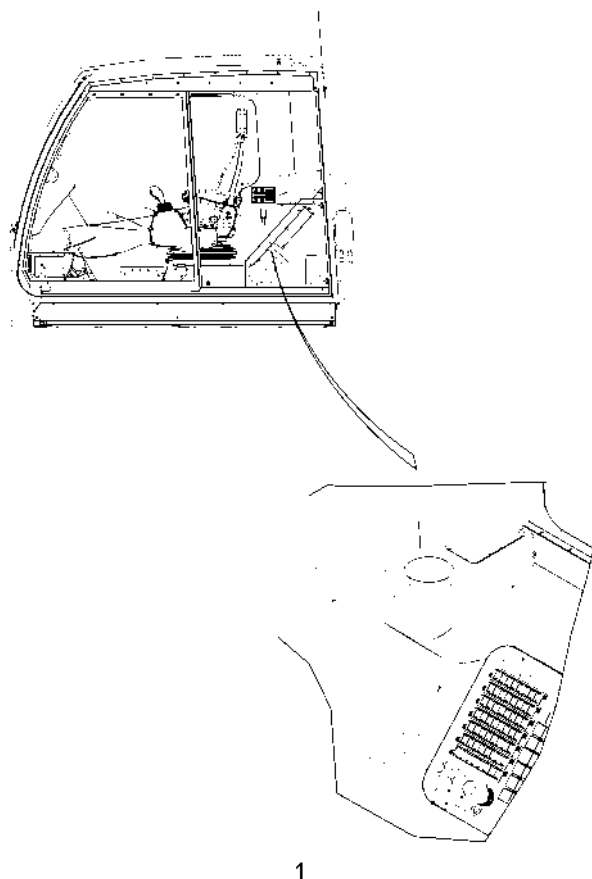

00520

A separate hourmeter (1) is provided for monitoring the operating hours of hoisting gear 1. The hourmeter starts functioning as soon as the winch is activated.

### 3.13.2 Hourmeter for hoisting gear 2

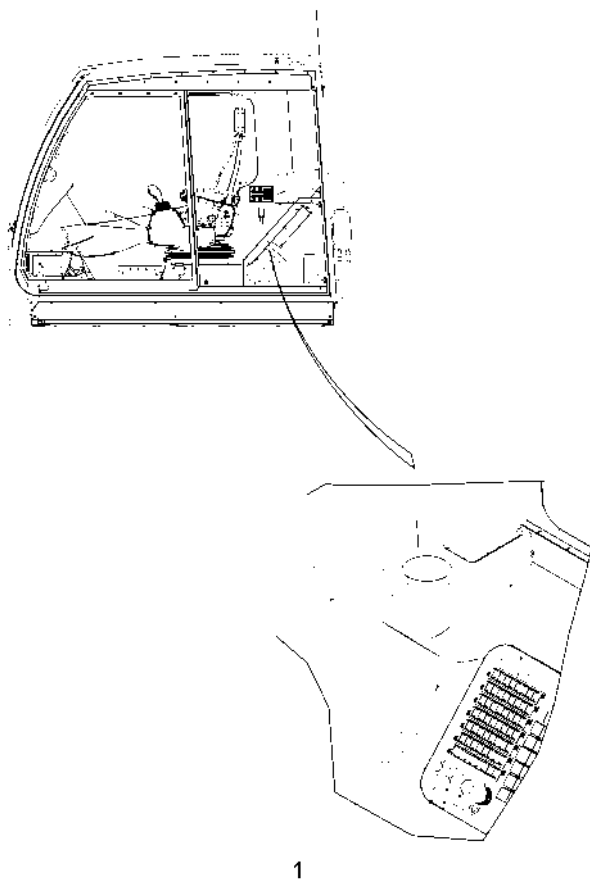

0052B

A separate hourmeter (2) is provided for monitoring the operating hours of hoisting gear 1. The hourmeter starts functioning as soon as the winch is activated.

### 3.13.3 Observation mirror of hoisting gear 1



#### **NOTICE**

**The observation mirror is not folded in the driving mode!**

The observation mirror may tear off when driving over bridges, access roads, etc. having low access height. This may result in material damage to the mobile crane.

1. Fold the observation mirror before driving.

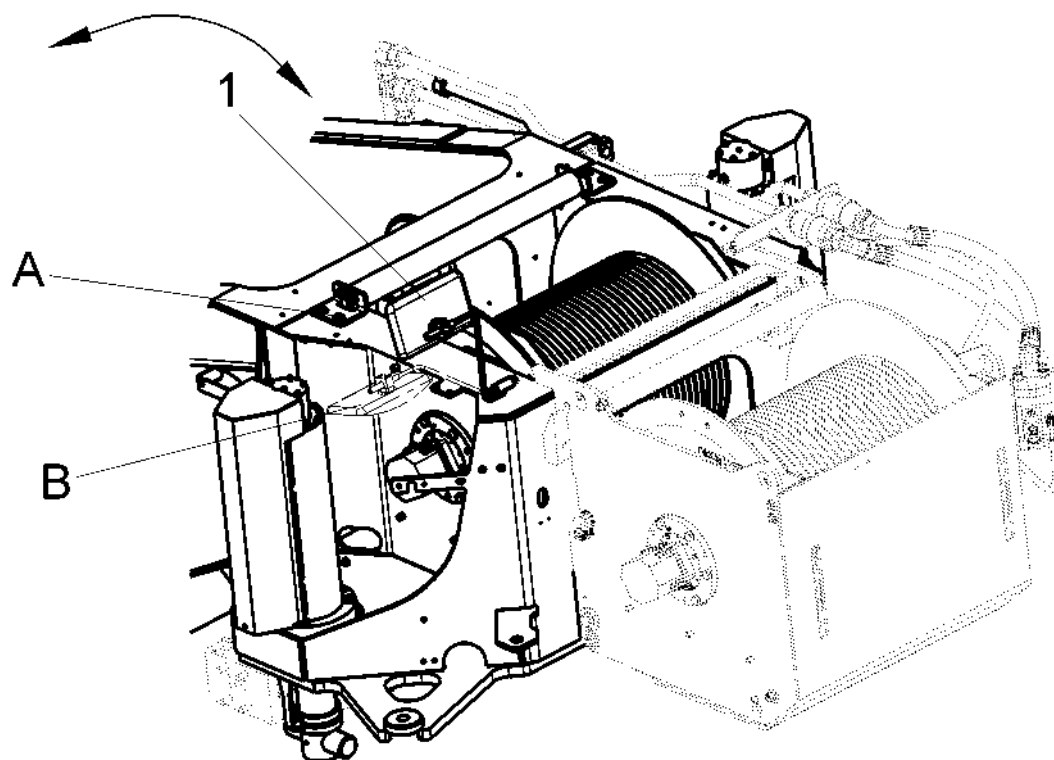

99707028566  
0/0209

Crane operation: observation mirror (1) in position A.

Driving mode: observation mirror (1) in position B.

### 3.13.4 Observation mirror of hoisting gear 2



#### **NOTICE**

**The observation mirror is not folded in the driving mode!**

The observation mirror may tear off when driving over bridges, access roads, etc. having low access height. This may result in material damage to the mobile crane.

1. Fold the observation mirror before driving.

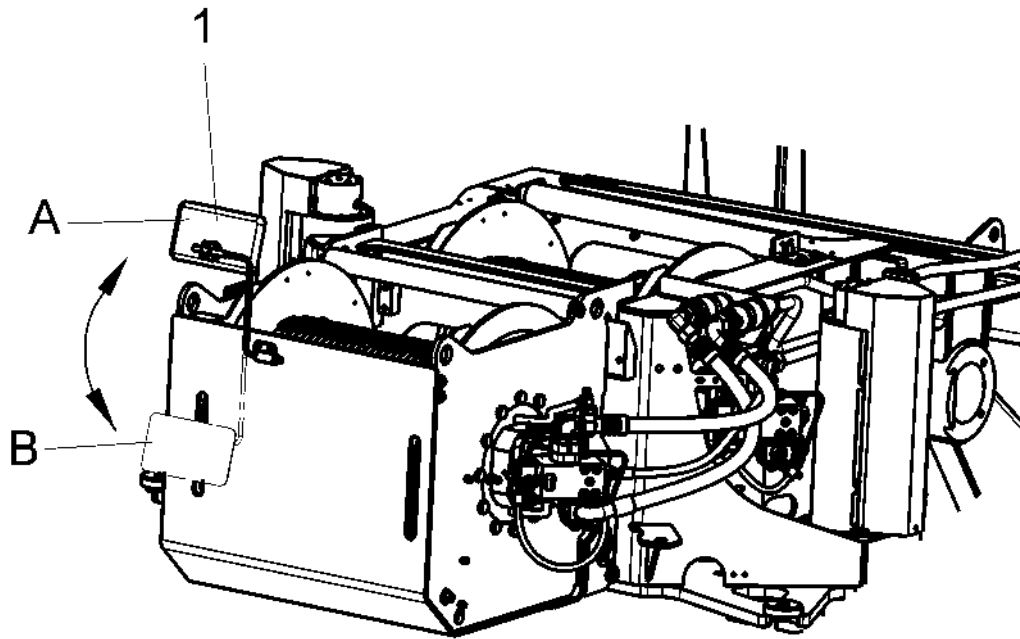

99707028567  
0/0209

Crane operation: observation mirror (1) in position A.  
Driving mode: observation mirror (1) in position B.

### 3.13.5 Charging socket and plugbox for starting via an external power source

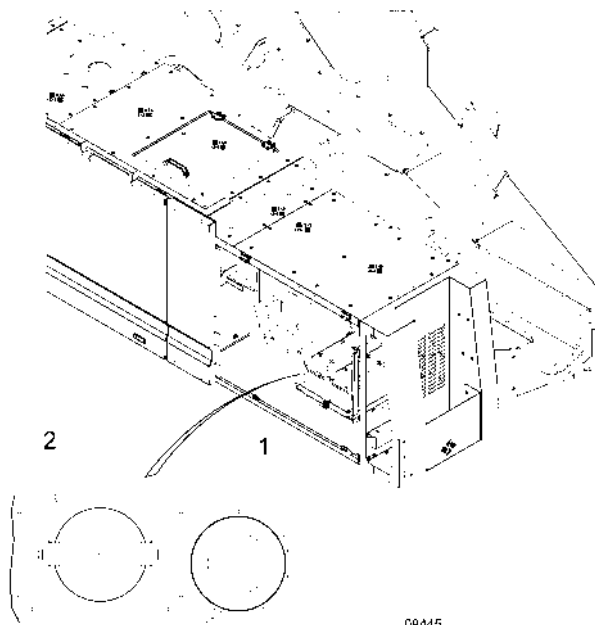

09445

1 Charging socket	2 Plugbox for starting via an external power source
-------------------	---

## Charging socket

	<b>NOTICE</b>
<p><b>Danger of short-circuit</b></p> <p>Do not use the charging socket for jump starting when the charger is connected. It is intended for charging the battery.</p>	

The charging socket (1) is provided on the battery compartment on the right side of the vehicle.

Charge the battery only with 24 V direct current.

Switch off all electrical consumers and the main switch of the battery during the charging process.

## Plugbox for starting via an external power source

The use of a plugbox for starting via an external power source is described in *Starting the Superstructure using External Current [page 457]*.

## 3.13.6 Load view camera\*)

Press the "Load view camera" rocker switch (1) down to switch on the load view camera on the boom head. The green pilot lamp in the switch lights up.

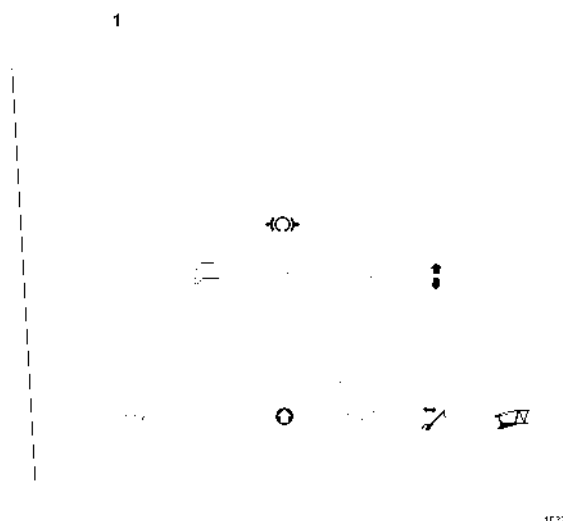

The camera image is displayed on the monitor (2).

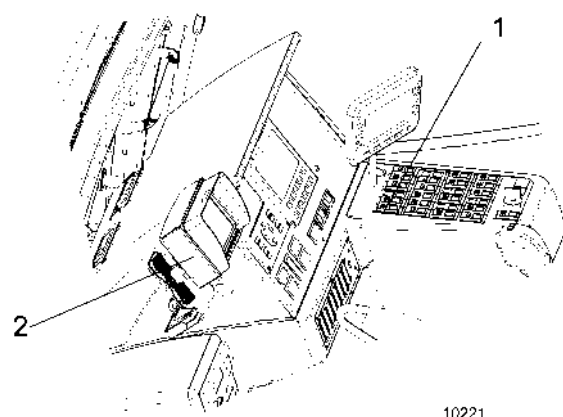

Press the "Load view camera" rocker switch (1) up to switch off the load view camera on the boom head. The green pilot lamps on the switch and the monitor go out.

### 3.13.7 Amot Control (engine stop)

#### Location

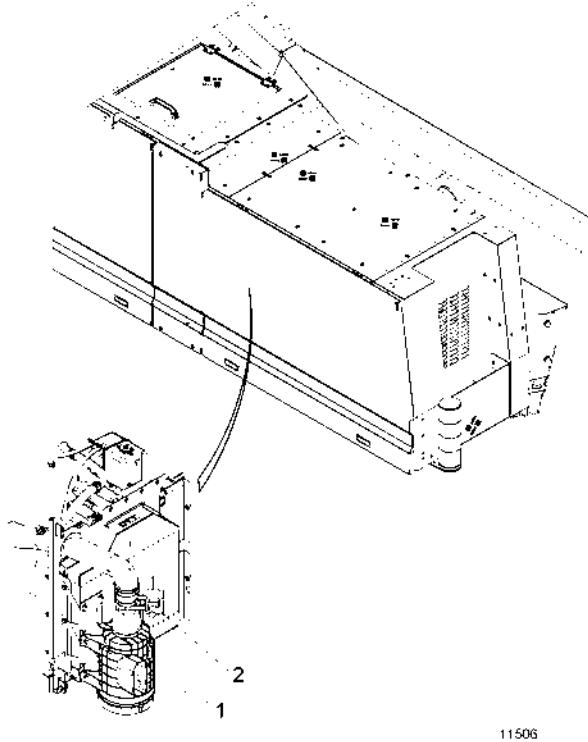

11506

1	Air cleaner	2	Air shut-off valve
3	Panel		

The air shut-off valve is located under the panelling.

#### Function

If the engine speed is too high, the air shut-off valve closes automatically and blocks the engine's air supply. The engine is stopped.

The air shut-off valve must be opened manually before the engine can be restarted.

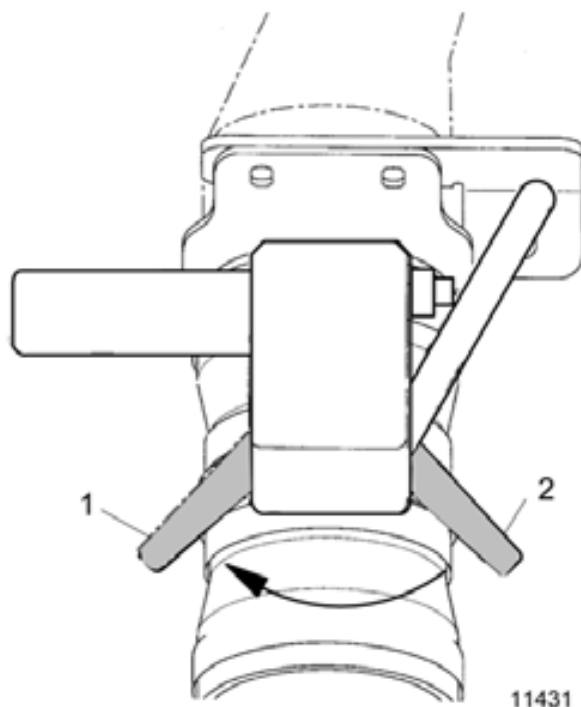

## Opening the air shut-off valve manually



1	Reset lever, open position	2	Reset lever, closed position
---	----------------------------	---	------------------------------

1. Open air shut-off valve.
2. Check the intake hoses for deformation and replace if necessary.

## 3.14 Winter operation

	 <b>WARNING</b>
	<p><b>Risk of accident due to snow and ice!</b></p> <p>Roof loads such as snow and ice can endanger the operator as well as other persons.</p> <p>Layers of snow and ice form a dangerous covering on roof surfaces, platforms and access steps of the mobile crane.</p> <ol style="list-style-type: none"> <li>1. Remove unsafe roof loads such as snow and loose chunks of ice before starting work.</li> <li>2. Remove snow and ice from windshields and mirrors before starting work.</li> <li>3. Remove snow and ice from the access steps and platforms before climbing up.</li> </ol>

	<b>⚠ CAUTION</b>
	<p><b>Freezing of uncovered skin!</b> In case of severe frost, uncovered skin can freeze onto bare metal surfaces.</p> <ol style="list-style-type: none"><li>1. Do not touch metal surfaces with uncovered skin.</li><li>2. Wear gloves to protect hands.</li></ol>

Keep the following points in mind for a smooth and safe winter operation.

#### 3.14.1 Engine

##### Fuel

	<b>NOTICE</b>
	<p><b>Malfunctions due to incorrect fuel!</b> At low ambient temperatures, the flowability of diesel drops and can cause malfunctions.</p> <ol style="list-style-type: none"><li>1. Use antifreezing diesel in the months of winter.</li><li>2. Follow the enclosed operating manual of the engine manufacturer.</li></ol>

##### Engine oil

	<b>NOTICE</b>
	<p><b>Damage to the engine due to incorrect engine oil!</b> Engine oil with incorrect viscosity can damage the engine.</p> <ol style="list-style-type: none"><li>1. Choose the SAE class corresponding to the expected ambient temperatures during the utilization period. For approved engine oils, please refer to the fuel specifications of the engine manufacturer.</li><li>2. Follow the enclosed operating manual of the engine manufacturer.</li></ol>

##### Coolant and anti-freeze

	<b>NOTICE</b>
	<p><b>Damage to the engine due to missing antifreezing agent!</b> The coolant can freeze and damage the engine.</p> <ol style="list-style-type: none"><li>1. Check the antifreeze property of the coolant in time and increase the percentage of antifreezing agents if required.</li><li>2. Follow the enclosed operating manual of the engine manufacturer.</li></ol>



## AdBlue® in winter operation

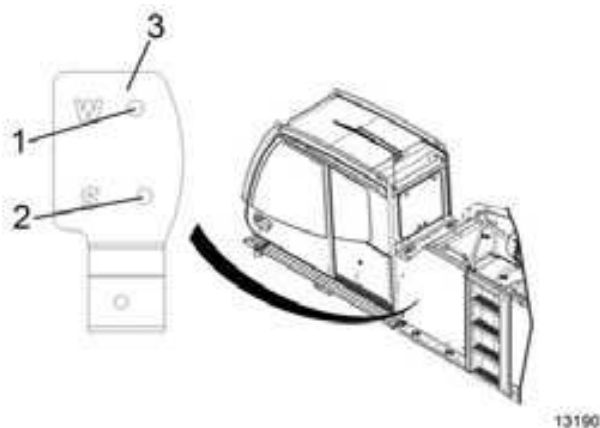

1	Winter operation (W)	3	Locking plate
2	Summer operation (S)		

**NOTICE****Frozen AdBlue®.**

Malfunction in the SCR system (exhaust treatment) in winter.

1. Switch heating for AdBlue® ON in time at temperatures below freezing point.

AdBlue® freezes at temperatures below  $-11\text{ °C}$  ( $12\text{ °F}$ ).

Depending on the outside temperature, switch the supplementary heater unit in the crane cab ON approx. 1 hour before starting work.

AdBlue® must be liquid at the time when working is started!

**Switching heating ON**

1. Switch change-over valve behind the crane cab to winter operation; to do this lift the locking plate and switch change-over valve from summer operation to winter operation. Release locking plate.
2. Switch supplementary heater unit in crane cab ON.

**NOTICE****Overheated AdBlue®.**

Malfunction in the SCR system (exhaust treatment) while the heating is switched ON in summer.



1. At summer temperatures, switch heating for AdBlue® OFF in time.

AdBlue® flocculates at temperatures above approx.  $60\text{ °C}$  ( $140\text{ °F}$ ) and becomes useless.

**Switching heating OFF**

1. Switch change-over valve behind the crane cab to summer operation; to do this lift the locking plate and switch change-over valve from winter operation to summer operation. Release locking plate.

#### 3.14.2 Hydraulic system

	<p><b>NOTICE</b></p> <p><b>Damage to the hydraulic pump due to high speed at very low oil temperatures!</b></p> <p>Higher engine speeds and cold hydraulic oils can damage the hydraulic pumps.</p> <p>There is the risk of failure of hydraulic pumps.</p> <ol style="list-style-type: none"><li>1. Ensure that engine speeds are not high when cold hydraulic oils are used.</li><li>2. Preheat the oil according to heating instructions.</li><li>3. Exchange the hydraulic oil</li></ol>
	<p>In case of wintry ambient temperatures and cold hydraulic oil, the "Hydraulic filter contaminated" symbol may light up due to the cold hydraulic oil.</p> <p>The warning lamp disappears when the hydraulic oil attains the operating temperature.</p> <p>If the symbol continues to glow when the hydraulic oil is warm, change the hydraulic oil filter.</p>

Pay attention to the minimum temperature limit of the oil.

The hydraulic oil used may still be used up to 10 °C (50 °F) below its minimum temperature limit. If the ambient temperature is below this limit, use a suitable oil. Keep the recommended oils in mind.

#### Heating instructions for hydraulic oils

The hydraulic oil will soon be brought closer to the operating temperature by "lowering" (moving on the block) or "extending or retracting" several times.

The maximum permissible operating temperature is approximately 70-80 °C (158-176 °F).

## Switching to another oil

	<b>NOTICE</b>
	<p><b>Hydraulic pump damage due to choosing the wrong oil!</b></p> <p>When the hydraulic system is operated with hydraulic oil such as Renolin Xtreme Temp 46+, damage to the hydraulic pumps can occur in wintry ambient temperatures.</p> <p>There is the risk of failure of hydraulic pumps.</p> <ol style="list-style-type: none"> <li>1. Change oils and use the hydraulic oils specified for the ambient temperatures.</li> </ol>



The oil may only be changed at a specialist workshop.

## 3.14.3 Windshield washing system

	<b>! WARNING</b>
	<p><b>Freezing up of the splash water nozzles!</b></p> <p>If the washer nozzle freezes up, the windshields can no longer be cleaned using the windshield washing system. The vision is severely impaired in such cases and it may lead to accidents.</p> <ol style="list-style-type: none"> <li>1. Increase the percentage of the antifreezing agent corresponding to the ambient temperature.</li> </ol>

## 3.15 Operation in case of an emergency

	<b>! WARNING</b>
	<p><b>Risk of accident!</b></p> <p>Operating a mobile crane with failures is prohibited. The operational safety is no longer ensured. This may result in severe accidents.</p> <ol style="list-style-type: none"> <li>1. Initiate emergency measures.</li> <li>2. Contact the TADANO dealers responsible for maintenance and inspection.</li> </ol>

	<p><b>⚠ WARNING</b></p> <p><b>Risk of accident!</b>          Never substitute the use of regular operating elements with emergency controls.</p> <ol style="list-style-type: none"> <li>1. Repair the damaged control and operating elements immediately.</li> </ol>
	<p><b>⚠ WARNING</b></p> <p><b>Valve failure!</b>          Damage to the rubber caps of emergency controls may lead to the valve failure.</p> <ol style="list-style-type: none"> <li>1. Do not operate emergency controls having rubber caps using sharp-edged or pointed objects.</li> <li>2. Replace the damaged rubber caps immediately.</li> </ol>

3.15.1 Crane control

	<p><b>⚠ WARNING</b></p> <p><b>Risk of accident while resetting!</b>          The lack of circumspection when resetting may lead to accidents.</p> <ol style="list-style-type: none"> <li>1. If the superstructure is moved using emergency controls, unauthorized persons may not be present in the movement range.</li> <li>2. The operator must be able to see the movement range. If this is not the case, the operator must work with another person, i.e. a marshaler.</li> </ol>
<p><b>i</b></p>	<p>In case of a failure or malfunctions in different control or actuating elements or faults in the electric system, failed functions can sometimes be executed using emergency controls. These emergency controls must however be used only for stopping the crane movements and dismantling the crane. The cause of the damage must then be determined immediately and rectified. See the following graphics for the position of solenoid valves.</p>

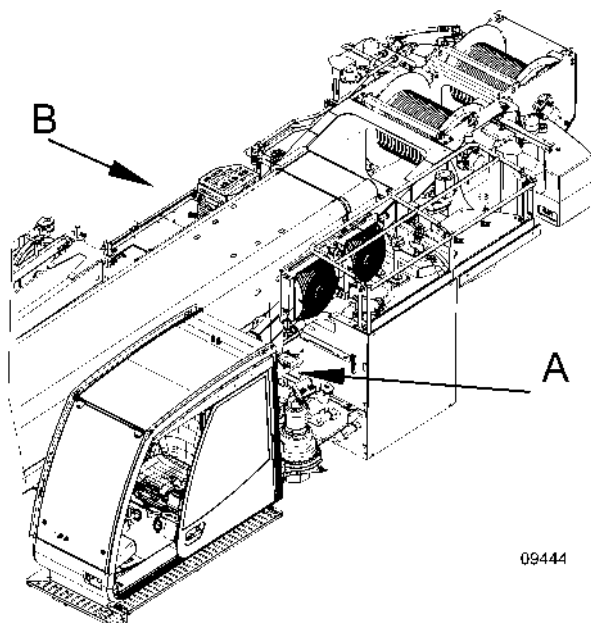



09444

**Prerequisite:**

- The engine is in the idling mode.
- The mobile crane is supported.

**Counterweight:**

Counterweights up/down; lock/unlock	A	A
1 = lock counterweight 2 = counterweight up, 6 = counterweight down, 7 = unlock counterweight, For this, press 2 = activate counterweight.	 <p style="text-align: center;">Driving direction</p>	 <p style="text-align: center;">Driving direction</p>

**Slewing the superstructure**

Before actuating control valves 8 and 9, the plugs must be disconnected and connected again after actuation.

5 = release the slewing gear brake

For this,

8 = turn to the right

or

9 = turn to the left

and

4 = arm rest override  
must be actuated.

#### Hydraulic pumps for crane control

<b>i</b>	<p>If the pump controller fails, the hydraulic pumps can be activated via emergency control. Crane movements are then possible.</p> <p>Before actuating control valves 1 and 2, the plugs must be disconnected and connected again after actuation.</p>
<p>1 = hydraulic pump 1 2 = hydraulic pump 2</p>	<p>B</p>  <p>Driving direction</p>

#### 3.15.2 Failure of components or central unit of the safe load indicator

	<p><b>! WARNING</b></p>
	<p><b>Crane operations with overridden automatic safe load indicator!</b></p> <p>The mobile crane can be overloaded if the automatic safe load indicator is overridden. This may lead to an accident.</p> <p>Only the authorized personnel may use the override function in emergency cases and when the automatic safe load indicator fails.</p>
<b>i</b>	<p><b>Overriding the automatic safe load indicator when its central unit is failed leads to:</b></p> <ol style="list-style-type: none"> <li>1. Reduction in operating speeds.</li> <li>2. Deactivation of sensitive control of crane movements.</li> <li>3. Activation of manual telescope control.</li> <li>4. The working speeds can be regulated only to a limited extent using the engine speed.</li> </ol>

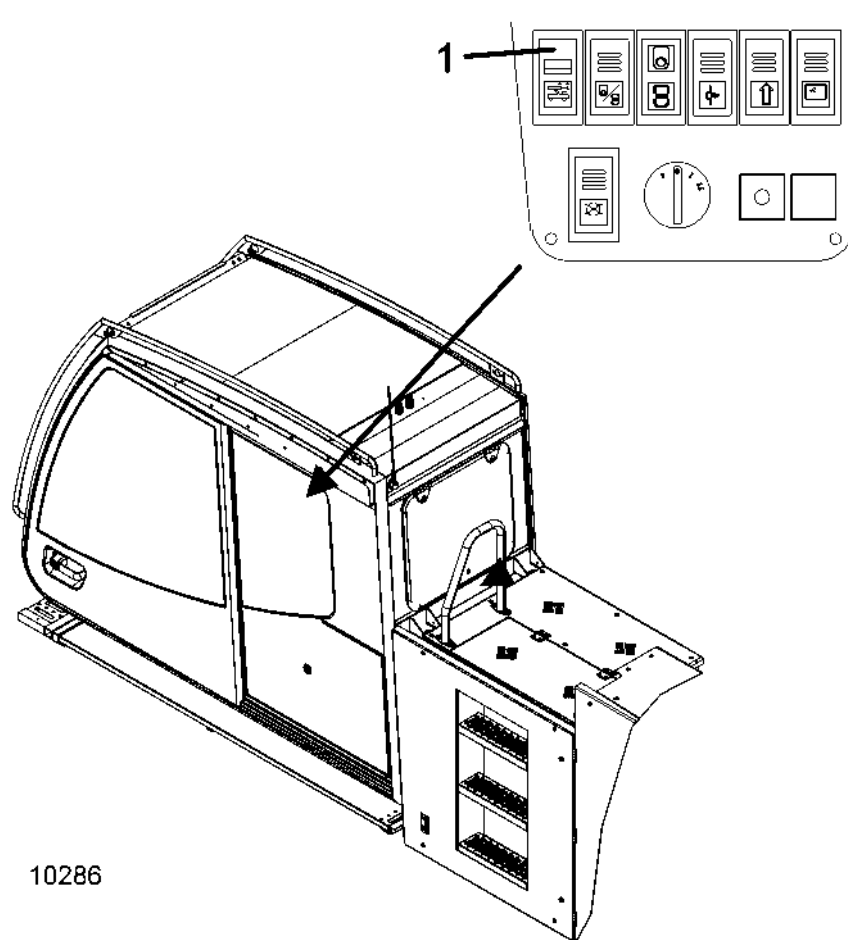

10286

1	"Manual control" switch
---	-------------------------

To override the automatic safe load indicator in an emergency or if components or the central unit of the safe load indicator fail:

operate the "Manual control" switch (3).

The overriding is automatically reset when the engine stops or after a maximum of 30 minutes.

The procedure for resetting the telescopic boom is described under "Resetting the telescope manually".

3.15.3 Resetting telescope manually

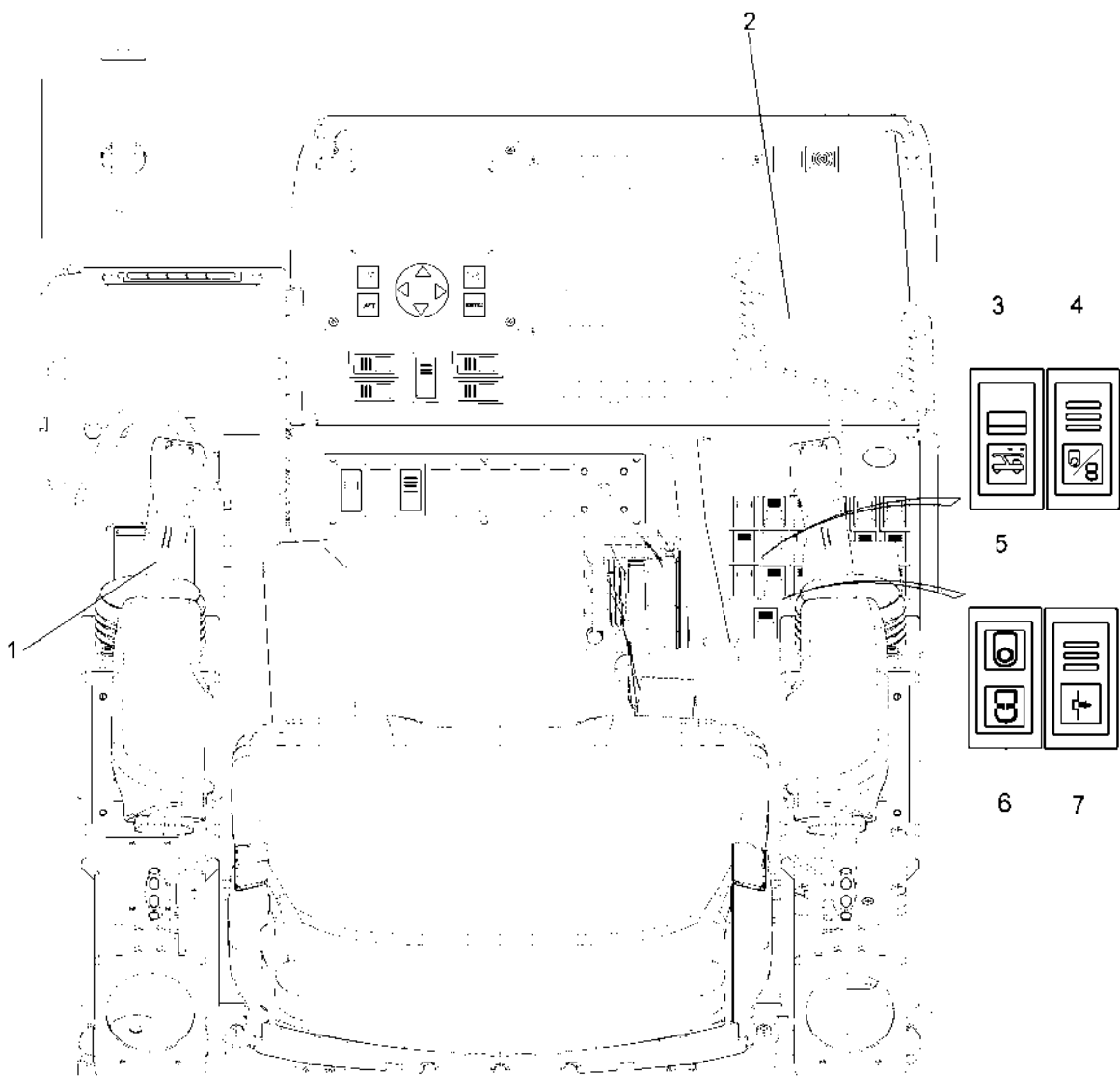

09413

1	Left crane control lever	5	Cylinder lock pilot lamp
2	Telescope monitor	6	Telescope lock pilot lamp
3	Rocker switch for manual actuation of telescope	7	Rocker tip switch for releasing the lock
4	Rocker switch for pre-selecting the telescope/ cylinder		



Pilot lamps of the control element:

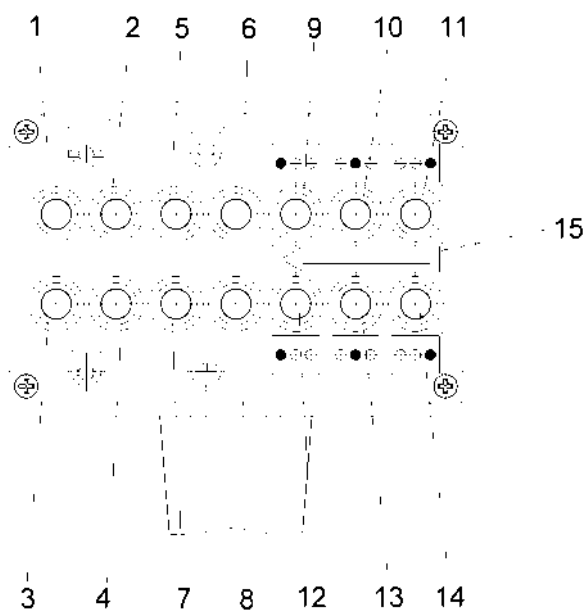

99707782469  
B/1007

1	Lock left cylinder	9	Telescope ID for telescope 2
2	Lock right cylinder	10	Telescope ID for telescope 1
3	Unlock left cylinder	11	Telescope ID for all telescopes
4	Unlock right cylinder	12	Telescope ID for telescope 5
5	Lock left telescope	13	Telescope ID for telescope 4
6	Lock right telescope	14	Telescope ID for telescope 3
7	Unlock left telescope	15	Direction arrow, extension direction
8	Unlock right telescope		

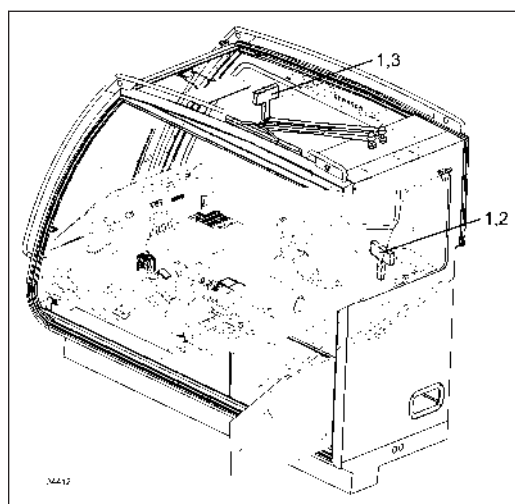

The control element (1) is provided in the crane cab. In case of manual resetting, remove the control element (1) from the bracket (2) and insert it into the bracket (3).

In case of a failure of the automatic telescope mode, the telescope can be controlled manually using the "Manual telescope control" rocker tip switch.

**Prerequisite:**

- The mobile crane is supported as prescribed.
- The boom should be raised to an angle  $> 70^\circ$ .
- If the jib is mounted, the boom should be raised to an angle  $> 75^\circ$ .
- No persons may be present during the resetting process.
- Always monitor the bottom block during the telescoping movement.
- The "Telescope control" display is shown on the Telescope monitor.

	<b>NOTICE</b>
	For manual telescoping, it is possible to extend the lifting cylinder to the front beyond the cylinder guide of the respective telescope. When retracting, the telescope ID proximity switch may get damaged under unfavorable conditions. In order to minimize this RISK, raising the boom to the maximum possible distance is recommended before retracting the lifting cylinder.

**Possible reasons for a failure of the automatic telescope mode are:**

**Functional error when telescoping**

If the automatic unit fails when unpinning the cylinder or a telescope part, relieving the stress on the telescope using the manual telescope control is recommended before complete manual resetting.

For this, activate the manual telescope control using the "Manual telescope actuation" rocker switch and pull back the crane control lever for approximately 3 - 4 seconds. Then deactivate the manual telescope control again. Normally, the automatic operation can then be carried out again. If this measure is not successful, the boom must be dismantled manually.

Follow the instructions in Table 1 for this purpose.

	<b>! DANGER</b>
	<b>Overriden automatic safe load indicator</b> The safety device of the automatic safe load indicator is overridden by activating the manual telescope control. The mobile crane may be overloaded if it is operated with active override device. Risk of accident!  1. The manual telescope control must be used only for retracting (resetting) the telescope. Carry out all crane movements with utmost care and caution.

After activating the manual telescope control, the functions such as derricking, telescoping, hoisting gear 1 and hoisting gear 2\*) as well as the swing mechanism are available.

The crane control lever can be used only for activating/deactivating the crane movement. Speeds can be regulated to a limited extent using the engine speed.

Actuate the swing mechanism only at the idling speed and when the boom length is shortest possible.

**ID errors**

When an "ID error" occurs, it is displayed.





There are two types of errors.

If one sensor triggers the error, the mobile crane can be further operated without any restrictions.

If both essential sensors trigger the error, telescopes must be reset manually.

Follow the instructions in Table 1 for this purpose.

If all sensors fail, K964 (pins 30/87) must be overridden for unlocking the telescope pins.

	 <b>DANGER</b>
	<b>Telescope cylinder not locked</b> Ensure that the telescope cylinder in a telescope is locked.
	 <b>DANGER</b>
	<b>Overriden automatic safe load indicator</b> The safety device of the automatic safe load indicator is overridden by activating the manual telescope control. The mobile crane may be overloaded if it is operated with active override device. Risk of accident!  1. The manual telescope control must be used only for retracting (re-setting) the telescope. Carry out all crane movements with utmost care and caution.

After activating the manual telescope control, the functions such as derricking, telescoping, hoisting gear 1 and hoisting gear 2\*) as well as the swing mechanism are available.



The crane control lever can be used only for activating/deactivating the crane movement. Speeds can be regulated to a limited extent using the engine speed.

Actuate the swing mechanism only at the idling speed and when the boom length is shortest possible.

**Locking error**

If a "locking error" occurs, telescopes must be reset manually.

Follow the instructions in Table 1 for this purpose.

	 <b>DANGER</b>
	<b>Overriden automatic safe load indicator</b> The safety device of the automatic safe load indicator is overridden by activating the manual telescope control. The mobile crane may be overloaded if it is operated with active override device. Risk of accident!  1. The manual telescope control must be used only for retracting (re-setting) the telescope. Carry out all crane movements with utmost care and caution.



After activating the manual telescope control, the functions such as derricking, telescoping, hoisting gear 1 and hoisting gear 2\*) as well as the swing mechanism are available.

The crane control lever can be used only for activating/deactivating the crane movement. Speeds can be regulated to a limited extent using the engine speed.

Actuate the swing mechanism only at the idling speed and when the boom length is shortest possible.

#### Error in the telescope length sensor

If an error occurs in the telescope length sensor, the ASLI is deactivated due to overload. Telescopes must be reset manually. Use the "Manual telescope actuation" rocker switch to activate the manual telescope control and follow the instructions in Table 1.

	 <b>DANGER</b>
	<p><b>Overriden automatic safe load indicator</b></p> <p>The safety device of the automatic safe load indicator is overridden by activating the manual telescope control. The mobile crane may be overloaded if it is operated with active override device. Risk of accident!</p> <ol style="list-style-type: none"> <li>1. The manual telescope control must be used only for retracting (re-setting) the telescope. Carry out all crane movements with utmost care and caution.</li> </ol>

After activating the manual telescope control, the functions such as derricking, telescoping, hoisting gear 1 and hoisting gear 2\*) as well as the swing mechanism are available.

The crane control lever can be used only for activating/deactivating the crane movement. Speeds can be regulated to a limited extent using the engine speed. Maximum speeds of all movements are considerably reduced.



Actuate the swing mechanism only at the idling speed and when the boom length is shortest possible.

#### Failure of automatic safe load indicator (ASLI)

It is deactivated due to overload. Telescopes must be reset manually. Use the "Manual telescope actuation" rocker switch to activate the manual telescope control and follow the instructions in Table 1.

K964 (pins 30/87) must be overridden for unlocking the telescope pins.



	 <b>DANGER</b>
	<p><b>Telescope cylinder not locked</b></p> <p>Ensure that the telescope cylinder in a telescope is locked.</p>

	 <b>DANGER</b>
	<p><b>Overriden automatic safe load indicator</b></p> <p>The safety device of the automatic safe load indicator is overridden by activating the manual telescope control. The mobile crane may be overloaded if it is operated with active override device. Risk of accident!</p> <ol style="list-style-type: none"><li>1. The manual telescope control must be used only for retracting (re-setting) the telescope. Carry out all crane movements with utmost care and caution.</li></ol>

After activating the manual telescope control, the functions such as derricking, telescoping, hoisting gear 1 and hoisting gear 2\*) as well as the swing mechanism are available.

The crane control lever can be used only for activating/deactivating the crane movement. Speeds can be regulated to a limited extent using the engine speed.

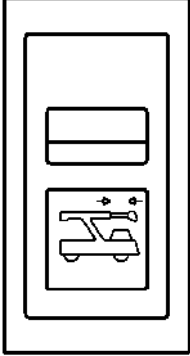
Actuate the swing mechanism only at the idling speed and when the boom length is shortest possible.

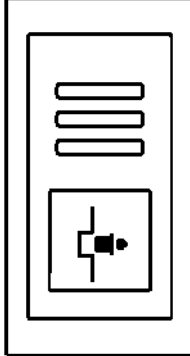
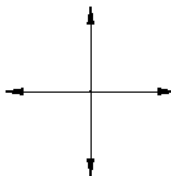
<p><b>Table 1:</b> <b>Resetting telescope manually</b></p>	<p><b>Rocker switch 3</b> (S925) Manual telescope actuation</p>	<p><b>Rocker switch 4</b> (S909) Pre-selecting the telescope/cylinder</p>	<p><b>Rocker tip switch 7</b> (S910) Release the lock</p>	<p><b>Left crane control lever (JS)</b></p>
	<p>off</p>  <p>on with locking handle</p>	<p>on (C) cylinder</p>  <p>From the central position</p> <p>on (B) telescope</p>	<p>off</p>  <p>off</p>	<p>Tele off</p>  <p>Tele on</p>
<p><b>1. Activate manual control</b> Prerequisite: Tele (B-pin) locked and cyl. (C-pin) locked in a tele (see reading in Tab. 2).</p>	<p>Locking handle downwards, "On" position, Light active</p>	off	off	neutral
<p><b>2. Telescope (B)-pins unlocked</b> and simultaneously move "Tele off" using the JS until B-pins are completely unlocked (see reading in Tab. 2).</p>		on (B)	off	Tele off
<p>3. After unlocking the B-pins, <b>keep the B-pins unlocked</b></p>		on (B)	off	neutral
<p>4. Retract the telescope completely to 0% using the JS (see reading in Tab. 3).</p>		on (B)	off	Tele on
<p><b>5.Lock B-pins</b> (see reading in Tab. 2).</p>		off	off	neutral
<p><b>6. Unlock cylinder C-pins</b> completely (see reading in Tab. 2).</p>		on (C)	off	neutral
<p>7. After unlocking the C-pins, <b>keep the C-pins unlocked.</b></p>		on (C)	off	neutral
<p>8. Extend the cylinder up to the next telescope using the JS (follow the telescope ID and the locking position, see reading in Table 3).</p>		on (C)	off	Tele off
<p><b>9. Lock C-pins</b> (see reading in Tab. 2). If required, use "Tele off"/"Tele on" to move the cylinder carefully until it is completely locked.</p>		off	off	Tele off/Tele on

10. Retract all other telescopes as described from point no. 2 onwards.		See from no. 2 onwards	See from no. 2 onwards	See from no. 2 onwards
11. After retracting the entire telescope, <b>deactivate the manual control</b> . Telescope and cylinder pins are moved to the locking position.	"Off" position, Light deactivated	off	off	neutral

<b>Table 2:</b> Control readings I	Control element Locking-pin reading	Telescope monitor Tele-cylinder length sensor reading
Cylinder (C)-pins locked and Telescope (B)-pins unlocked	 <p style="text-align: center;">10138</p>	
Cylinder (C)-pins locked and Telescope (B)-pins locked	 <p style="text-align: center;">10139</p>	
Cylinder (C)-pins unlocked and Telescope (B)-pins locked	 <p style="text-align: center;">10140</p>	

Table 3: Control readings II	Control element Telescope identification (ID)	Tele-cylinder length sensor			
		0%	46%	92%	100%
Telescope 1		0.00 m	4.32 m	8.64 m	9.48 m
Telescope 2		0.29 m	4.61 m	8.93 m	9.75 m
Telescope 3		0.57 m	4.89 m	9.21 m	9.99 m
Telescope 4		0.84 m	5.16 m	9.48 m	10.26 m
Telescope 5		1.10 m	5.42 m	9.74 m	10.52 m

Further information:



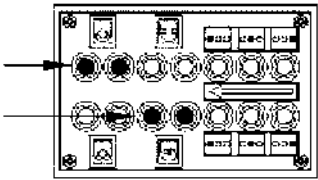
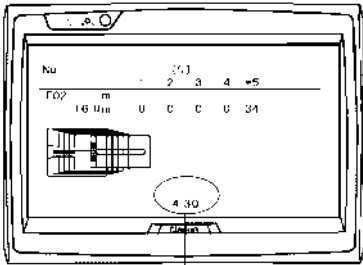
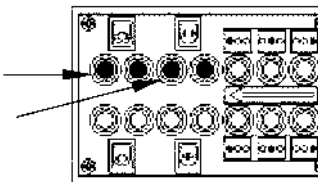
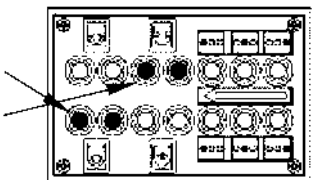
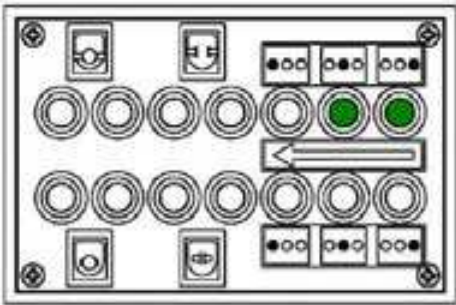
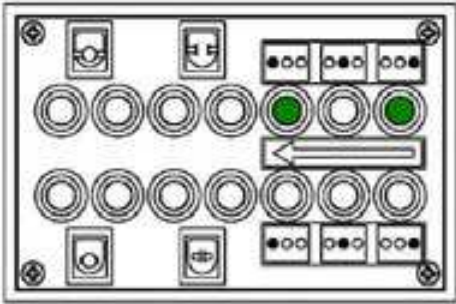
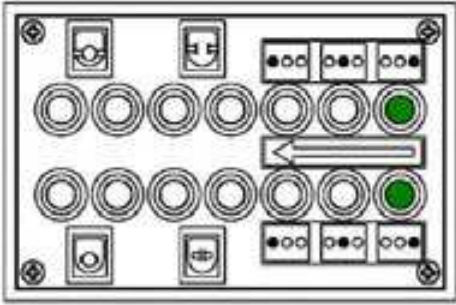
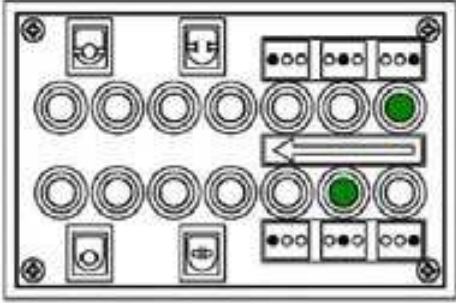
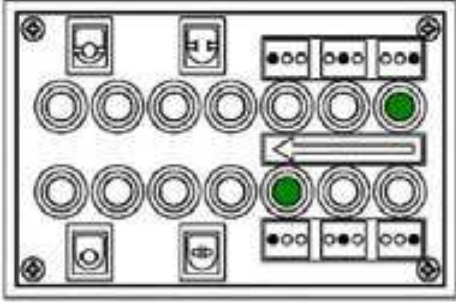

- After activating the manual control, all locks are first set to the pinned position or the floating position.
- If there is no clarity regarding the position of the lifting cylinder with respect to the first telescope to be moved, retract the lifting cylinder completely after unlocking the cylinder pins. Press the left crane control lever to the back until the cylinder length reading becomes 0. If the cylinder length has failed, monitor the cable drum at the lower side of the boom. Follow the instructions from no. 6 onwards in Table 1.
- Near the locking positions of telescopes or cylinders, move the crane control lever by short distances with the engine running at idle.

#### Initializing the telescope display

After resetting the telescopes manually and locking the telescopes and cylinders completely, an incorrect percentage display of actual telescope positions or the main boom length may be possible. In such a case, an expert must initialize the displays.

#### 3.15.4 Slewing the superstructure

	 <b>WARNING</b>
	<p><b>The counterweight is not in its correct position!</b></p> <p>The superstructure can be slewed only via the emergency control. The carrier assembly may get damaged if the counterweight is not completely at the top. Risk of accident due to damaged vehicle parts.</p> <ol style="list-style-type: none"> <li>1. Carry out slewing movements with utmost care. Find out the faults, e.g. leaking counterweight cylinders, and rectify the faults immediately.</li> </ol>

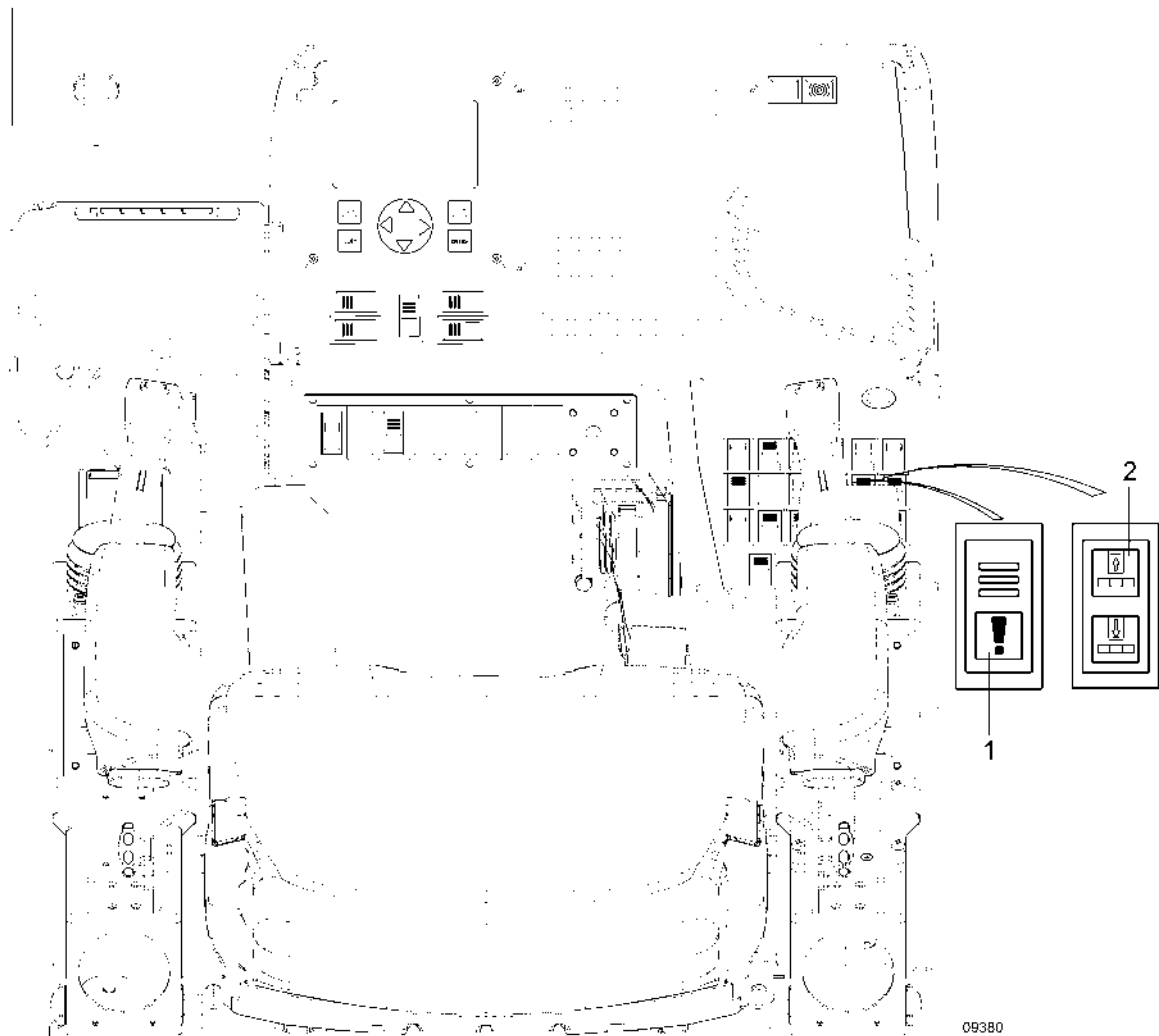

1 Rocker tip switch for overriding the swing mechanism/counterweight	2 Counterweight not up pilot lamp
--	-----------------------------------

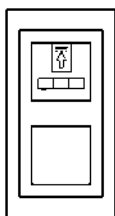
	<p>If the "Counterweight not up" warning lamp lights up when operating the crane, the counterweight is not in its correct position.</p>
---	---

The superstructure cannot be slewed!

If the counterweight cylinder cannot be retracted using the "Counterweight up/down" rocker tip switch:

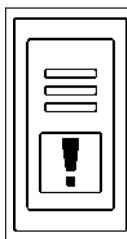

Press the "Override the swing mechanism/counterweight" rocker tip switch.  
The superstructure can be slewed.

### 3.15.5 Counterweight



#### **WARNING**

##### **Crane control in the emergency mode!**

Safety and warning devices do not function in the emergency mode.  
Risk of accident!

1. Carry out all crane movements with utmost care.

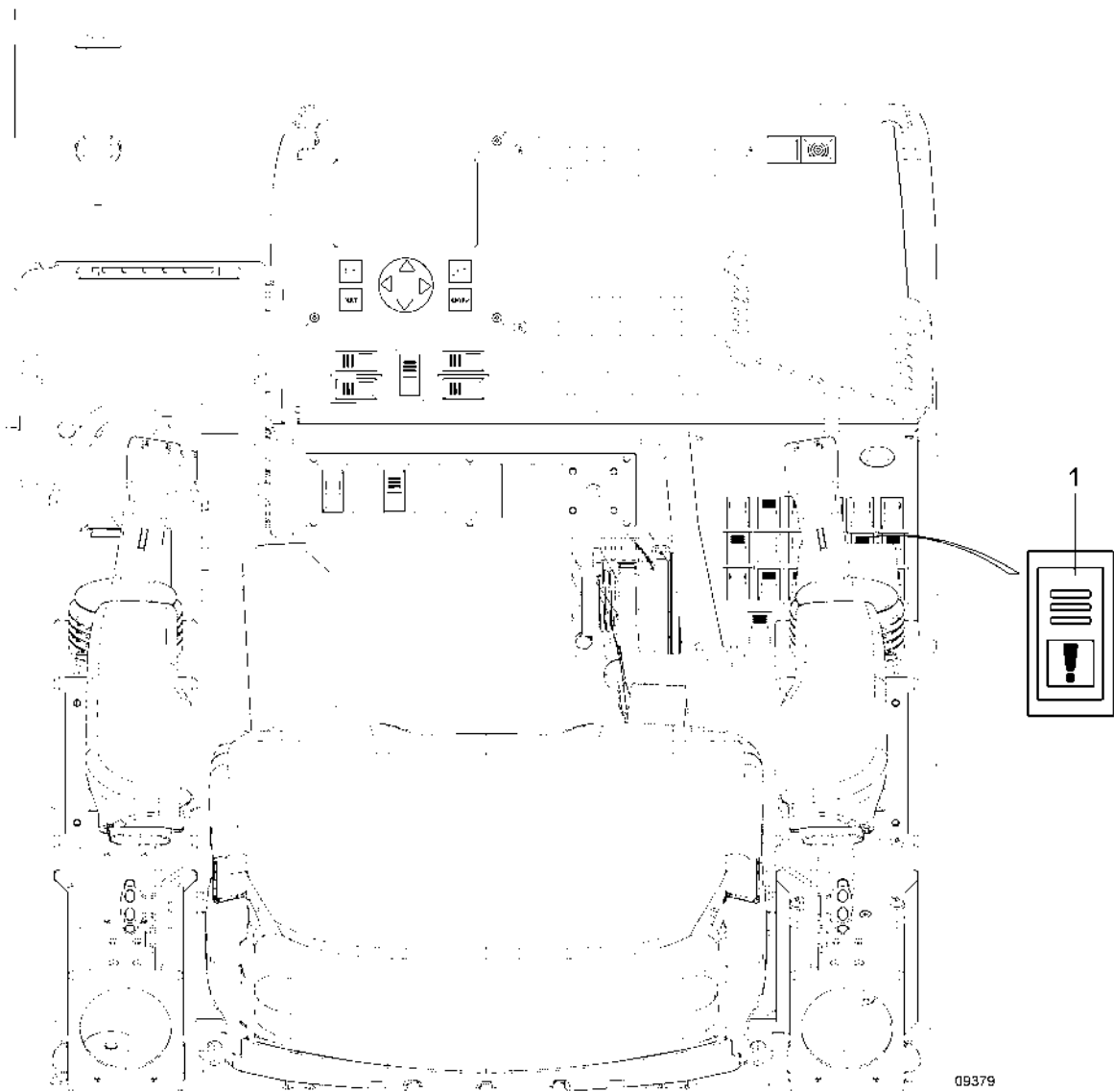

1 | Rocker tip switch for overriding the swing mechanism/counterweight





Prerequisite:

- A crane movement is stopped.
- Actuation is not possible using the regular operating elements.

Failed function	Prerequisite for overriding	Override
Counterweight cylinder down	The superstructure is mechanically locked	Press the "Override the swing mechanism/counterweight" rocker tip switch
Lock the counterweight	The superstructure is mechanically locked and the counterweight cylinder is down	Press the "Override the swing mechanism/counterweight" rocker tip switch
Unlock the counterweight	The superstructure is mechanically locked and the counterweight cylinder is down	Press the "Override the swing mechanism/counterweight" rocker tip switch

## 3.15.6 Drive unit

## Emergency start/stop

	<p style="text-align: center;"> <b>DANGER</b></p> <p><b>Risk of injuries due to rotating parts!</b> Rotating parts can crush or tear off body parts, and fatal injuries can result.</p> <ol style="list-style-type: none"> <li>1. Remove engine covers only in an emergency or to carry out maintenance work.</li> <li>2. Carry out maintenance work only when the engine is stationary.</li> <li>3. When working in the immediate proximity of the engine, make sure that you do not touch or get too close to rotating parts.</li> <li>4. Wear close-fitting clothes, tie up long hair and protect it with a hair net.</li> </ol>
	<p style="text-align: center;"> <b>CAUTION</b></p> <p><b>Risk of burns!</b> The engine and lines are hot when the engine is running.</p> <ol style="list-style-type: none"> <li>1. Do not touch hot parts when operating the emergency start/stop function of the engine.</li> </ol>
	<p>The emergency start/stop function of the engine may be used only for completing the crane movement and supporting the mobile crane. Other operations are not allowed under load.</p>

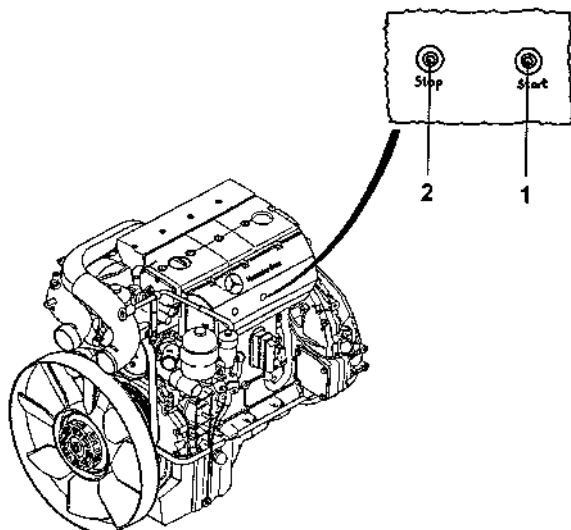

98213

1 "Engine start" button	2 "Engine stop" button
-------------------------	------------------------

The buttons for the emergency start/emergency stop function are located on the side of the engine.

#### Starting/stopping the engine using the emergency start/stop function

##### Prerequisite:

- Parking brake is engaged. The mobile crane is secured with chocks if necessary.
- The ignition in the superstructure has been switched on.
- The engine cover has been opened.

1. **Starting the engine:** Press the "Engine start" button.
  - ⇒ The engine will start and run at the idling speed.
2. **Switching off the engine:** Press the "Engine stop" button or the "Engine start" button again.
  - ⇒ The engine will stop.

##### Starting the engine and increasing the engine speed

1. Press the "Engine start" button and keep it pressed.
  - ⇒ The engine will start and run at the idling speed. The speed increases to the maximum within three seconds of starting the engine.
2. Release the "Engine start" button after reaching the required engine speed.
  - ⇒ The engine will continue to run at the current engine speed.

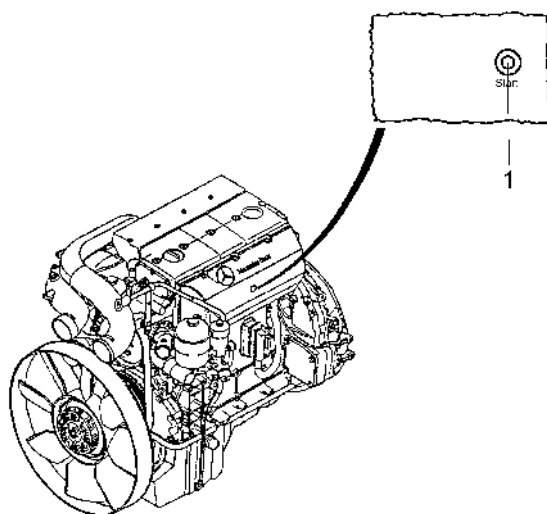
**Perform with one button**

1047

1	Button
---	--------

The buttons for the emergency start/emergency stop function are located on the side of the engine.

**Starting/stopping the engine using the emergency start/stop function**

Prerequisite:

- Parking brake is engaged. The mobile crane is secured with chocks if necessary.
- The ignition in the superstructure has been switched on.
- The engine cover has been opened.

1. **Starting the engine:** Press the "Engine start" button.
  - ⇒ The engine will start and run at the idling speed.
2. **Switching off the engine:** Press the "Engine start" button again.
  - ⇒ The engine will stop.

**Starting the engine and increasing the engine speed**

1. Press the "Engine start" button and keep it pressed.
  - ⇒ The engine will start and run at the idling speed. The speed increases to the maximum within three seconds of starting the engine.
2. Release the "Engine start" button after reaching the required engine speed.
  - ⇒ The engine will continue to run at the current engine speed.

**Fuel hand pump – fuel filter with a water separator**

The fuel filter with a water separator and a built-in hand pump are provided on the right side of the vehicle (see crane component assemblies, component installation location, item 5).

If dirt and/or air enter the fuel system, replace the filter element, clean the fuel system and bleed it.

The system needs to be bled and fuel needs to be fed using the hand pump

- after the fuel tank was empty,

- if leakages develop in the fuel system,
- after replacing the fuel filter (for replacing the filter, see Part "Servicing and maintenance of fuel superstructure").

#### Bleeding the system and feeding the fuel

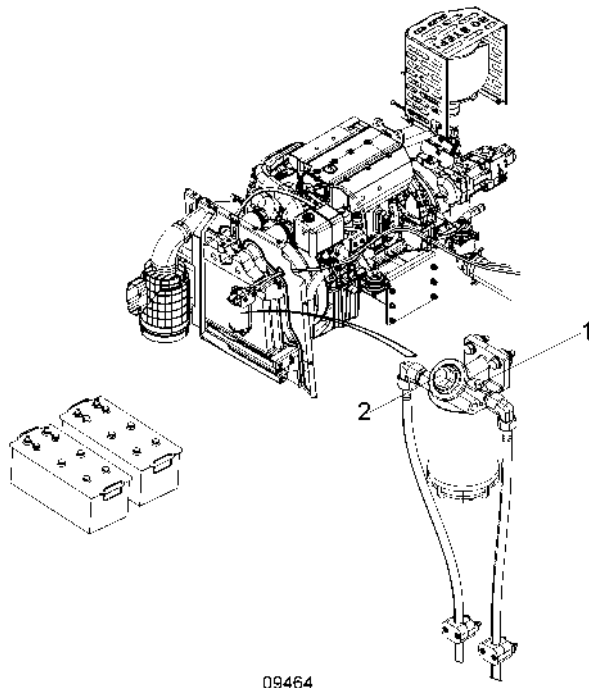



#### Prerequisite:

- Adequate fuel has been topped up.
  - Leakages have been rectified.
  - Filter cartridge has been replaced as described in Part "Servicing and maintenance of superstructure".
1. Loosen the bleed screw (1).
  2. Actuate the pump tappet (2) until the fuel emerging is free of air bubbles (collect the overflowing fuel in a suitable container and pour it in the fuel tank).
  3. Then tighten the vent screw (1) firmly.
  4. Start the engine. Start the engine. In case of starting troubles, ask an assistant to actuate the pump tappet until the engine starts running.



## Overheated drive unit

## Filling the coolant

	 <b>WARNING</b>
	<p><b>Risk of injuries!</b></p> <p>The cooling system is under excess pressure. Hot coolant can gush out when opening and scald your skin and eyes.</p> <ul style="list-style-type: none"> <li>▶ The coolant tank may be opened only when the coolant temperature drops below 90 °C (194 °F).</li> </ul> <ol style="list-style-type: none"> <li>1. Loosen the cap slowly using safety gloves or a cloth and release the excess pressure completely before opening.</li> </ol>

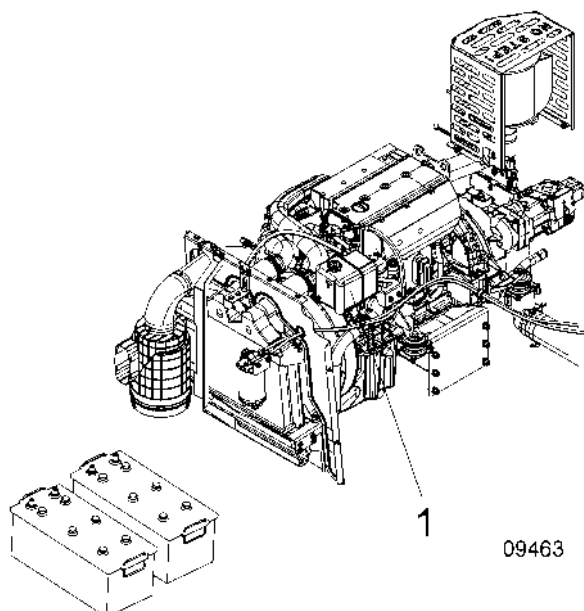

1. Remove the cap (1) of the coolant tank. If the coolant level is too low, fill the coolant in the coolant tank up to the 'Half' mark.

	<b>NOTICE</b>
	<p><b>Cold shock due to excessively cold coolant!</b></p> <p>If excessively cold water is filled in the overheated engine too quickly, the engine may get damaged. Always fill the cooling water gradually. If the coolant is not available, tap water can also be used temporarily. The tap water must be replaced with a regular coolant and, if required, the cooling system must be cleaned in the nearest workshop.</p>

2. Check whether the coolant is flowing out of the engine. Check whether the V-belt is damaged and the radiator is clogged. Other problems may occur.

### 3.15.7 Emergency stop switch for the superstructure

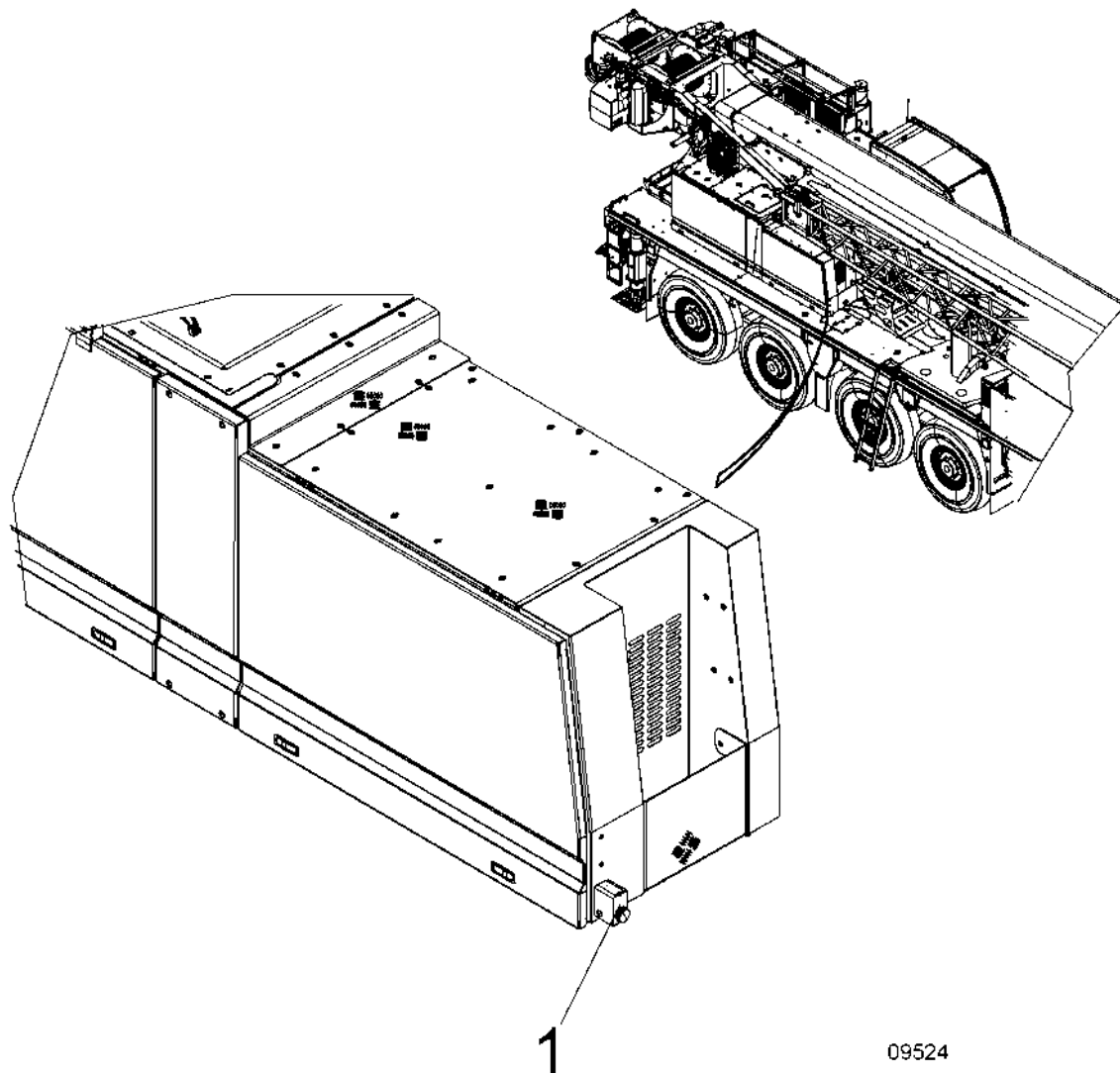

09524

Press the switch (1) to stop the running superstructure engine in case of an emergency. Press the switch again if the superstructure engine needs to be started again. The switch springs back to its initial position.

### 3.15.8 Starting the superstructure engine using external current



#### **NOTICE**

Never let the engine run without connecting a battery (either built-in or external battery).

Rectifier diodes in the three-phase generator may get damaged.

## Using the shunt cables

**NOTICE****Overvoltage!**

Carrying out these procedures incorrectly can result in damage to the generator.

The repair vehicle must have a 24 V system, the capacity of which must be at least equal to that of the broken-down vehicle (i.e. of the flat battery).

Do not touch the bare parts of the cable terminals and do not allow the positive cable (+) to touch any metal part of the chassis.

If the engine will not start due to a flat battery, it can be started with the batteries of another vehicle with the assistance of jump leads. However, only special purpose-made jump leads with a sufficient cable cross section may be used for this.

Batteries of the superstructure are provided on the right side of the vehicle.

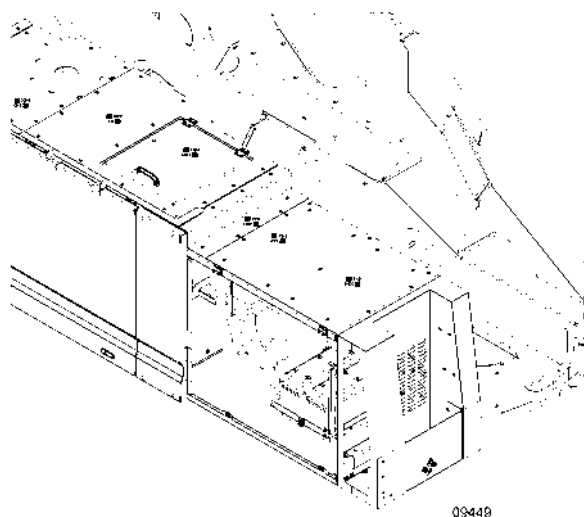

Recipient: Vehicle with a flat battery that cannot be started.

Donor: A vehicle with a charged battery that can be started.

- The batteries must be connected to the vehicles' system as specified. An interruption can cause the destruction of the generator rectifier.
  - Both vehicles must have 24 V systems. The total capacity (Ah) of the donor vehicle's batteries must not be significantly less than that of the recipient vehicle needing assistance.
  - Bring the batteries closer to each other. The chassis must not touch each other. So as to prevent a possible power flow, there must be no connection between the vehicles.
1. Open the access to the batteries (battery cover, pole protection caps).
  2. Switch off the radio and any unnecessary devices that consume power (in both the donor and recipient vehicles).

#### Connecting the jump leads

The sequence for connecting the jump leads must be followed!

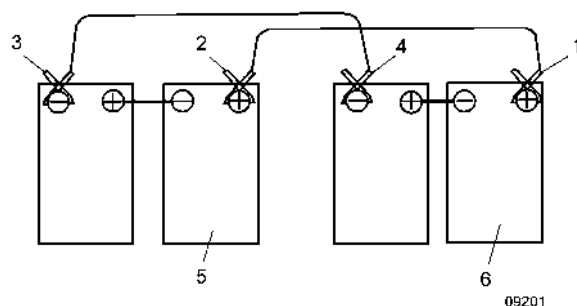

1	Positive pole (+) of the recipient battery	4	Negative pole (-) of the recipient battery
2	Positive pole (+) of the donor battery	5	Donor battery
3	Negative pole (-) of the donor battery	6	Recipient battery

1. Connect the red clamp (+) of the jump lead to the positive pole (+) of the recipient battery.
2. Connect the other red clamp (+) to the positive pole (+) of the donor battery.
3. Connect the black clamp (-) of the jump lead to the negative pole (-) of the donor battery.
4. Connect the black clamp (-) of the jump lead to the negative pole (-) of the donor battery.
5. Start the engine of the donor vehicle and allow it to run.
6. Start-up attempt on the recipient vehicle: Switch on the battery main switch, switch on the ignition, start the engine.
7. After starting the engine successfully, let it run for a few minutes.

#### Detaching the jump leads

The sequence for connecting the jump leads must be followed!

	<b>⚠ CAUTION</b>
	<p><b>Risk of burns</b></p> <p>The clamps of the jump leads may have become hot due to the high currents.</p> <ol style="list-style-type: none"> <li>1. Do not touch the bare parts of the cable terminals.</li> </ol>

1. Disconnect the black clamp (-) from the negative pole (-) of the recipient battery.
2. Disconnect the black clamp (-) from the negative pole (-) of the donor battery.
3. Disconnect the red clamp from the positive pole (+) of the donor battery.
4. Disconnect the red clamp from the positive pole (+) of the recipient battery.
5. Stow the jump leads, close the battery cover and terminal protection caps.
6. Allow the engine to run continuously for a period of time so as to charge the battery.

## Using the jump start socket\*)

**i**

The plugbox for starting via an external power source can be used to supply current for starting an external vehicle.

If the batteries of the vehicle are discharged or do not use their capacity, the engine can be started using external current.

Batteries of another vehicle having a 24-Volt system or the batteries of the carrier can be used as an external current source.

The prerequisite is that the external vehicle is equipped with a plugbox for starting via an external power source.

The plugbox for starting the superstructure via an external power source (2) is provided near the batteries

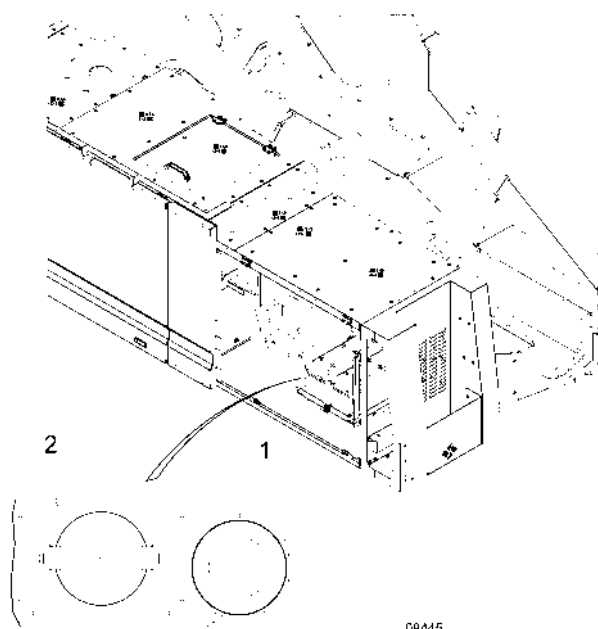

1	Charging socket	2	Plugbox for starting via an external power source
---	-----------------	---	---

The capacity (ampere) of the batteries of the current supplying vehicle must at least be equal to that of the receiver vehicle.

**Observe the following sequence in order to avoid damage to the generator.**

Current-receiving vehicle	Current-supplying vehicle
<ul style="list-style-type: none"> <li>▪ The ignition is switched off.</li> <li>▪ The main switch of the battery is switched off.</li> </ul>	<ul style="list-style-type: none"> <li>▪ The ignition is switched off.</li> <li>▪ The main switch of the battery is switched off.</li> </ul>
1. Connect the external current cable.	2. Connect the external current cable.
	3. Switch on the battery main switch. 4. Switch on the ignition. 5. Start the engine and let it run.
6. Switch on the battery main switch. 7. Switch on the ignition. 8. Start the engine and let it run for a few minutes.	
	9. Stop the engine, switch off the ignition and switch off the main switch of the battery.
10. Disconnect the external current cable.	11. Disconnect the external current cable.

#### 3.15.9 Emergency exit

If one cannot exit the crane cab through the cab door in case of an emergency, one can exit through the front windshield.

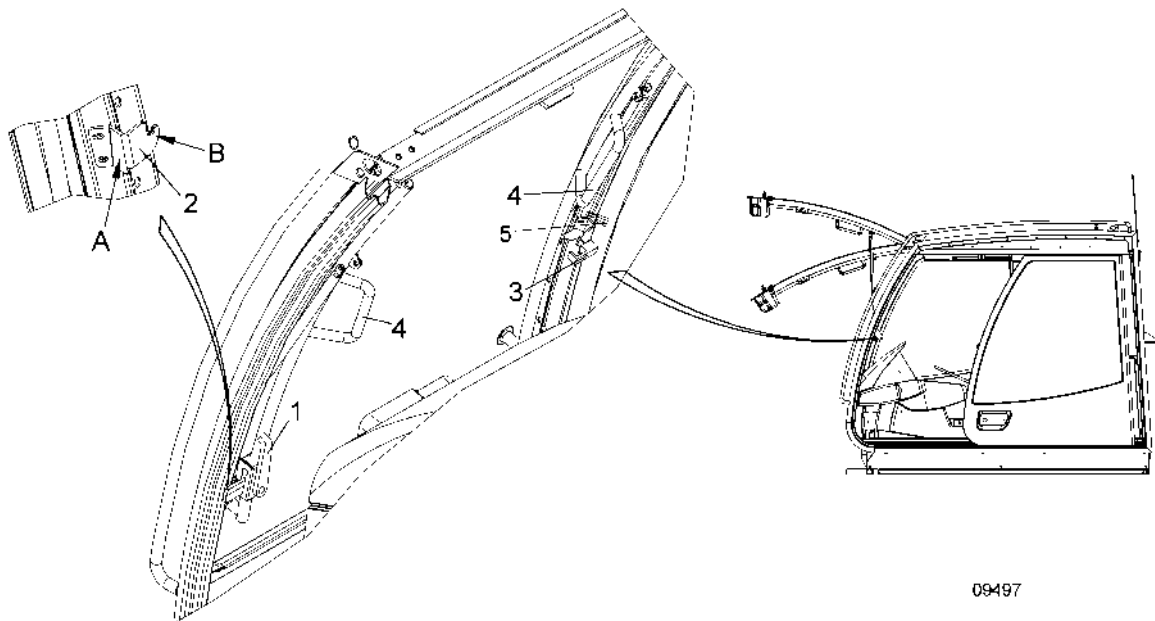

09497

#### Opening the front windshield

1. Unlock both levers.
  2. Open front windshield with both handles.
- ⇒ The front windshield slews up to the end position.

### 3.15.10 Superstructure emergency stop pushbutton

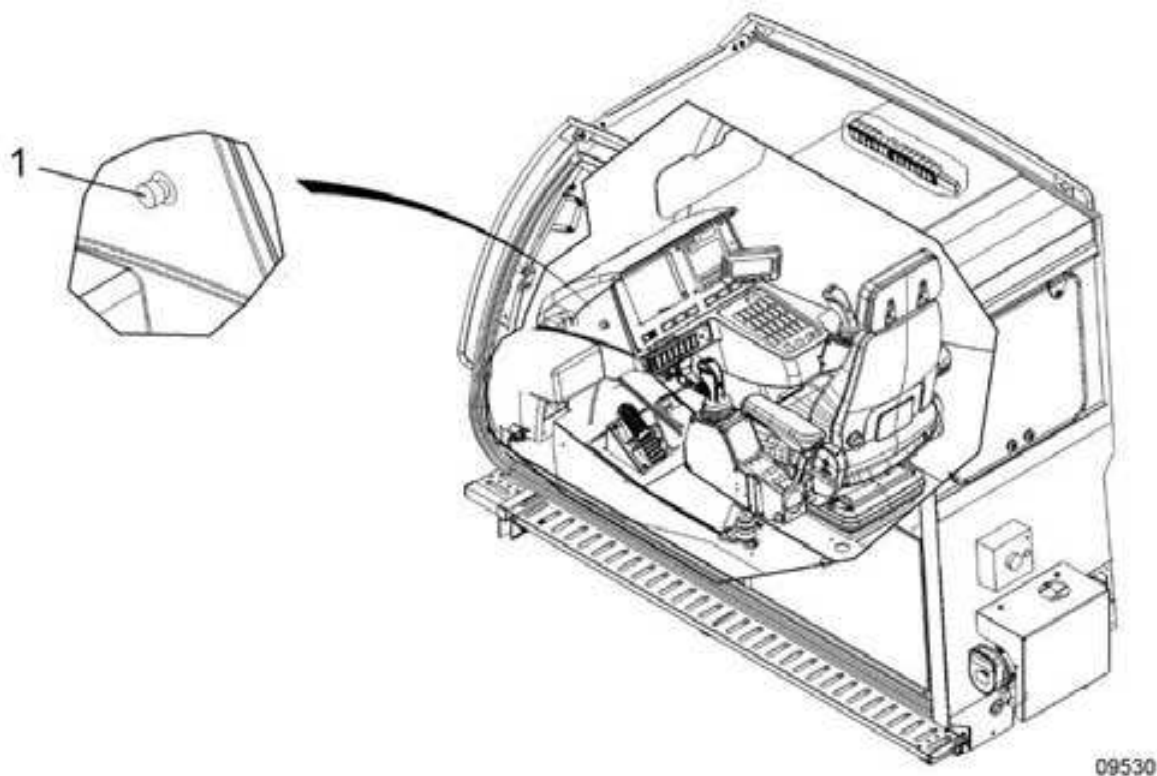

1	Superstructure emergency stop pushbutton
---	--

Press the switch (1) to stop the running superstructure engine in case of an emergency. If the superstructure engine needs to be restarted, turn the release ring in the switch in the arrow direction to the right. The switch then springs back to its initial position.

### 3.15.11 Emergency control/emergency release\*)



**i**

In case of the failure of the superstructure engine, the hydraulic pump or the electrical components in the superstructure, the oil supply connection for the superstructure hydraulic system can be established using hose assemblies with quick-locking couplings and a hydraulic engine pump unit driven by the hydraulic system of the carrier.

Owing to different sizes of quick-locking couplings, the possibility of any mix-up when connecting is ruled out.

The emergency operation of the superstructure is normally permitted only for resetting the crane from a working position in case of faults in energy supply.

The boom cannot be telescoped.

	<p style="text-align: center;"><b>! WARNING</b></p> <p><b>Persons on the working platform without functional emergency control!</b> If the superstructure engine fails, persons on the working platform cannot be rescued to a safe location under certain circumstances. Risk of accident/life.</p> <ol style="list-style-type: none"> <li>1. In case of special crane operations that may necessitate a quick emergency mode operation, the oil supply for the emergency control must be ensured before starting work. All possible resetting processes must be checked for functionality before using.</li> </ol>
	<p style="text-align: center;"><b>! WARNING</b></p> <p><b>Superstructure slews despite the connected hydraulic hoses!</b> Hydraulic hoses may get damaged and/or cracked. Escaping hydraulic oil may cause damage to the environment. The emergency control of the superstructure is no longer functional. Risk of accident/life.</p> <ol style="list-style-type: none"> <li>1. Decouple the connection lines on the superstructure to slew it.</li> </ol>
	<p style="text-align: center;"><b>! WARNING</b></p> <p><b>Carrying persons on the working platform with the 2nd hoisting gear!</b> Only the hoisting gear 1 can be reset using emergency control. Resetting is not possible in case of an emergency. Risk of accident/life.</p> <ol style="list-style-type: none"> <li>1. Persons may be carried only using the hoisting gear 1.</li> </ol>

**Establishing the oil supply between the carrier and the superstructure**

**In the carrier:**

The mobile crane is supported.

The carrier engine is stopped.

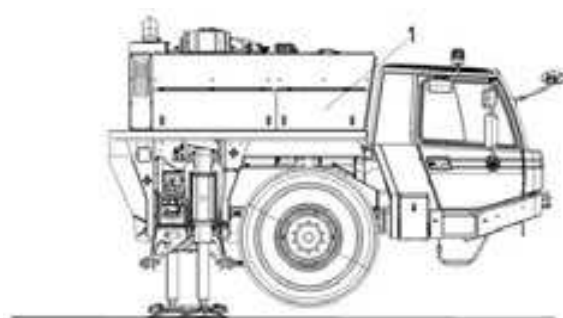

Open the shutter (1) and block using a supporting bar.

13160





Disconnect the plug (2) for the oil supply of the superstructure emergency control from the valve block.

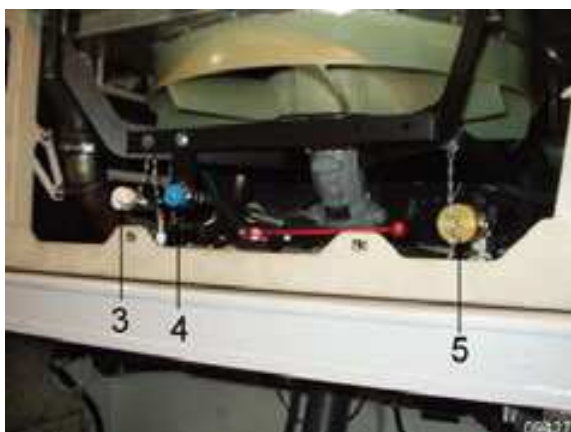

Remove the caps of quick-locking couplings (3 and 5).

Tighten the hose assemblies on the quick-locking couplings (3 and 5) up to the end stop.

**i**

Connection (4) = leakage line.

Not required for this mobile crane. Power can be fed to emergency controls of other mobile cranes from the carrier. If required, the leakage line (4) must be connected in such a case.

Follow the operating manual to the mobile crane to be reset.

**In the superstructure:**

Prerequisite:

Hose assemblies in the carrier are firmly bolted with the quick-locking couplings.

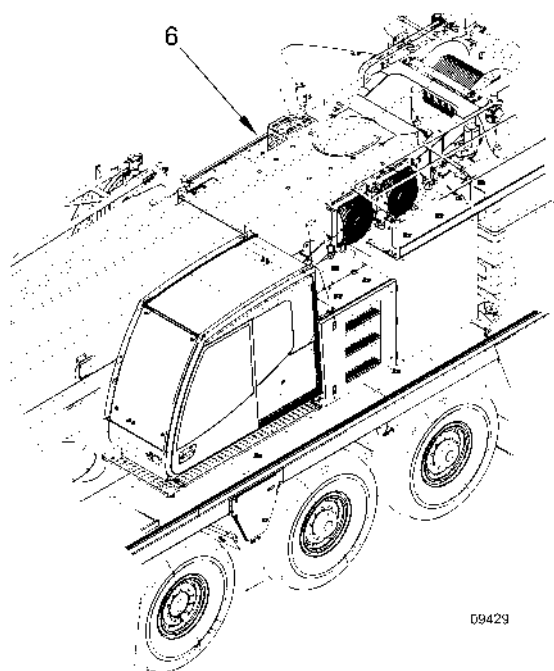

Open the cover (6).



Remove the caps of quick-locking couplings (7 and 8).

Tighten the hose assemblies on the quick-locking couplings (7 and 8) up to the end stop.





#### NOTICE

**Hose assemblies are not correctly screwed on the connections!**

If the hose assemblies are not firmly screwed on the connections, functions can no longer be guaranteed.

1. All hose assemblies must be screwed firmly with the quick-locking couplings.

## Resetting

	 <b>WARNING</b>
	<p><b>Errors while resetting!</b></p> <p>Warning devices of the automatic safe load indicator do not function while resetting. The mobile crane may be overloaded and may overturn. Oscillations may be induced if switching cocks are moved suddenly. Risk of accident!</p> <p>1. While resetting, always carry out the load moment-reducing movements (lower the load or raise the boom). Actuate the switching cocks carefully while resetting.</p>
<p><b>i</b></p>	<p>In the emergency mode, the automatic safe load indicator continues to work if the power supply of the superstructure is still activated. This information should be used for evaluating the risk.</p> <p>In case of the power failure in the superstructure, information of the automatic safe load indicator is no longer stored. Existing risks must then be evaluated using other information.</p>

**Prerequisite:**

Hose connections between the carrier and the superstructure have been established.

**In the carrier:**

Start the engine and bring the speed to approximately 1000 RPM.



Move the crossover cock (9) for the oil supply of the superstructure emergency control.

**In the superstructure:**

All switching cocks are in the initial position. No crane movements are possible.

Function of switching cocks:



10	Swing mechanism pre-selection crossover cock	13	Control lever
11	Boom derricking pre-selection crossover cock	10.1	Slewing gear brake crossover cock
12	Hoisting gear pre-selection crossover cock		

The superstructure is reset as follows:

Select the corresponding function. Move the crossover cocks 10, 11 or 12.

When selecting the swing mechanism (crossover cock 10), the slewing gear brake must also be released for the duration of actuation. Move the crossover cock 10.1.

Execute the desired crane function by actuating control lever 13.

Function	Pre-selection using the crossover cock	Actuate control lever 13
Slew the superstructure to the left	10 and 10.1	Tilt upward
Slew the superstructure to the right	10 and 10.1	Tilt downward
Raise boom	11	Tilt upward
Lower boom	11	Tilt downward
Hoisting gear 1, wind the hoisting rope	12	Tilt upward
Hoisting gear 1, unwind the hoisting rope	12	Tilt downward

After completing the emergency control, bring the levers of all crossover cocks back to the initial position.

### **Bring the mobile crane in the initial state:**

Carry out the following work steps after resetting the mobile crane:

Bring the switching cocks/plugs to the initial position.

Disconnect the hoses, remove and stow them.

Seal the connections of quick-locking couplings using caps.

Close the flaps and covers.



## 4 Crane testing instructions

### 4.1 Periodic tests of cranes

Every TADANO crane is checked before the delivery in accordance with the DIN standards and BGV D6 compliant accident prevention regulations prevailing in the Federal Republic of Germany. Accident prevention regulations applicable in the Federal Republic prescribe periodic annual tests, whereas the corresponding national regulations are applicable in other countries.

If national regulations do not exist in a particular country, we recommend conducting these periodic tests in accordance with the *BGV D6 accident prevention regulations* applicable in Germany.

Periodic annual tests for cranes can be conducted by crane experts and/or specialists. This test is primarily a visual inspection for assessing the condition of the entire crane and its components.

In addition, according to *BGV D6 accident prevention regulations (§ 26)*, a test must be conducted by an expert every 4 years. After the 13th year of operation, an annual test needs to be conducted by an expert.

The defects identified must be documented in the crane inspection log; the operating company is under obligation to rectify these defects. A subsequent test may be required.

The *VBG 9a accident prevention regulations* and/or BGR 500 Chapter 2.8 and/or the corresponding national regulations are applicable for the load handling equipment.



During the periodic tests, the automatic safe load indicator as well as the entire hydraulic and electrical control and safety devices must be checked.

The expert or the specialist is solely responsible for determining the complete scope of periodic tests.

A few important points to be considered during periodic tests are listed below.

However, we would like to emphasize that not all points in the scope of test are represented here.

### 4.2 Checking the load-bearing steel structures

	 <b>WARNING</b>
	<p><b>Damage to the load-bearing parts of the mobile crane.</b></p> <p>Damaged parts may fail under load. It may result in an accident involving personal injuries or even death.</p> <ol style="list-style-type: none"> <li>1. Check the parts subjected to loads regularly. Ask a specialist company to repair the damaged parts immediately.</li> </ol>

All load-bearing steel structures such as chassis frame, outrigger casings and outrigger beams (see crane testing instructions for the carrier), boom, superstructure rotary table with ball bearing slewing ring bolts, etc. must be checked regularly depending on the operating conditions, but at least once a year. Likewise, welding seams must be checked thoroughly even if they are subjected to lower loads.

If the crane is subjected to an impermissible load when operating (e.g. a high impact load due to a load falling on the rope or similar), the load-bearing parts of the device must be checked.





According to *DIN 15018 T3*, different stress tolerance coefficients are determined for different high-strength fine-grain construction steels. TADANO cranes have been designed in compliance with this standard for the load spectrum  $S_1$  light as well as a stress tolerance coefficient of 25000 load cycles. A suitable service life of a crane is determined based on this and the operating conditions. The service life does not depend solely on the specified stress tolerance coefficient, but primarily depends on the loads exerted on the crane during the operation period.

The following drawings [page 470] show a few load-bearing steel structures of the crane and give the tester a few indications regarding the points to be checked. Points marked with arrows are highly stressed zones and must be checked when testing and depending on the operating conditions.



We would however like to explicitly emphasize that the drawings do not claim to be complete. If damage (e.g. cracks, deformations) is detected during these tests, please contact an expert.

After inspecting the damage as per the instructions in the chapter "Welding and Alignment work" from the Maintenance and repair section, consult TADANO.

The repair method should then be decided on in consultation between TADANO and the expert.

	 <b>WARNING</b>
	<p><b>Welding activities not carried out properly!</b> Damaged parts may fail under load. It may result in an accident involving personal injuries or even death.</p> <ol style="list-style-type: none"><li>1. Only expert personnel may carry out welding activities.</li><li>2. Welding regulations must be observed implicitly.</li></ol>

### 4.2.1 Measures to protect electronic parts during welding

	 <b>CAUTION</b>
	<p><b>The ground terminal of the welding machine is connected to an incorrect point on the mobile crane!</b> The flow of current can cause damage to loose connections, e.g. tooth flanks, bearings, spline ends, shafts, the electronics, the automatic safe load indicator, etc.</p> <ol style="list-style-type: none"><li>1. When electrowelding, the ground terminal of the welding machine must be connected directly to the part to be welded.</li></ol>

If it is necessary to carry out welding on the mobile crane, the following steps must be carried out **before beginning** work to protect the electronic control units:

1. Switch off the battery main switches in the carrier and the superstructure,
2. Disconnect the battery cables at the negative poles in the carrier and the superstructure, then disconnect the battery cables at the positive pole and connect with each other,



- disconnect the plugs marked with "X" from the **electronic components** listed below (optional equipment, if any, is also shown):

**Under the front cover of the driver's cab:**

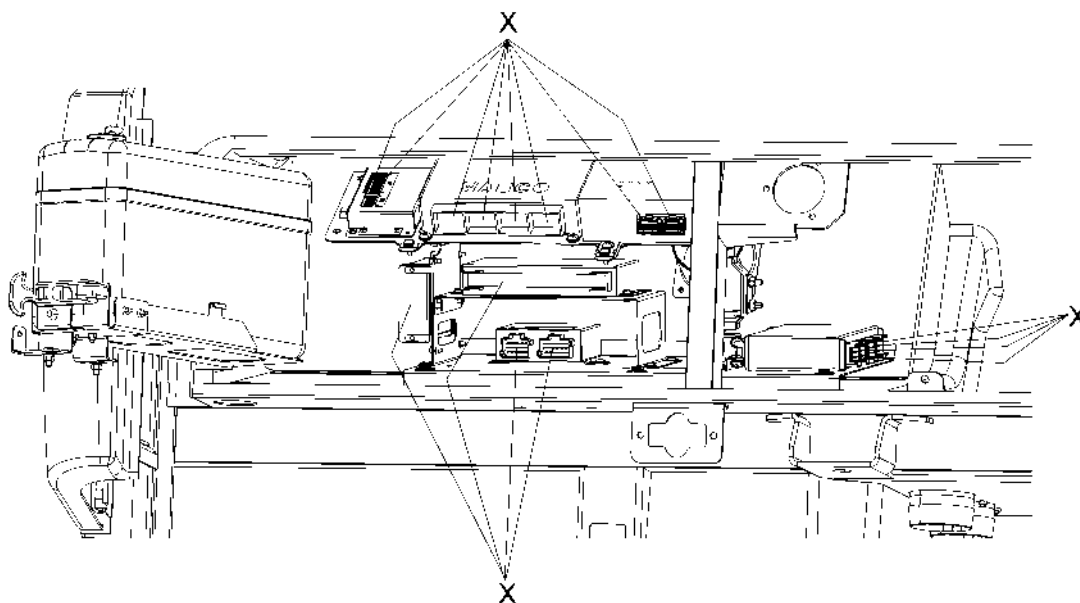

09594

**After removing the cover in the central console of the driver's cab in the carrier:**

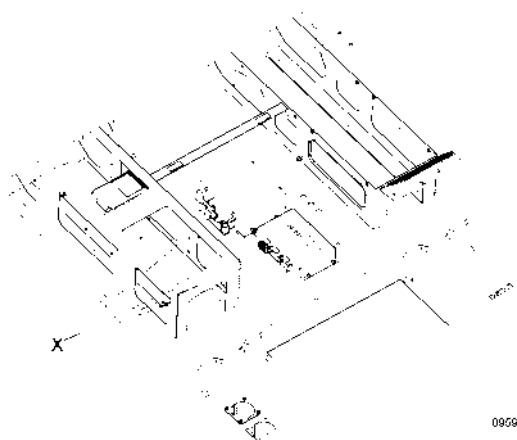

09095

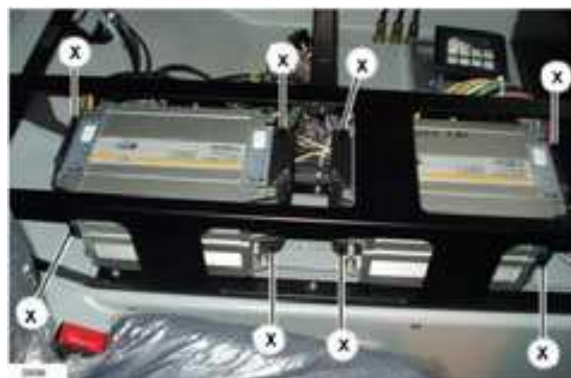

**Behind the switch boxes of the outrigger control on both sides of the vehicle:**

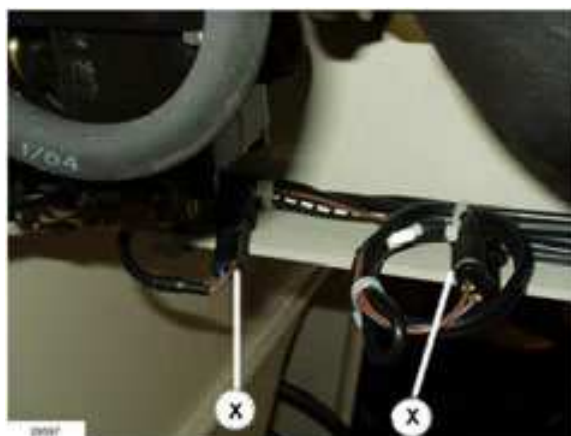

After completing the welding work, re-connect all plug connections with each other. We recommend marking the plug connections in order to avoid any kind of mix-ups when mounting.

### 4.2.2 Indicators for the points to be checked

#### Superstructure frame

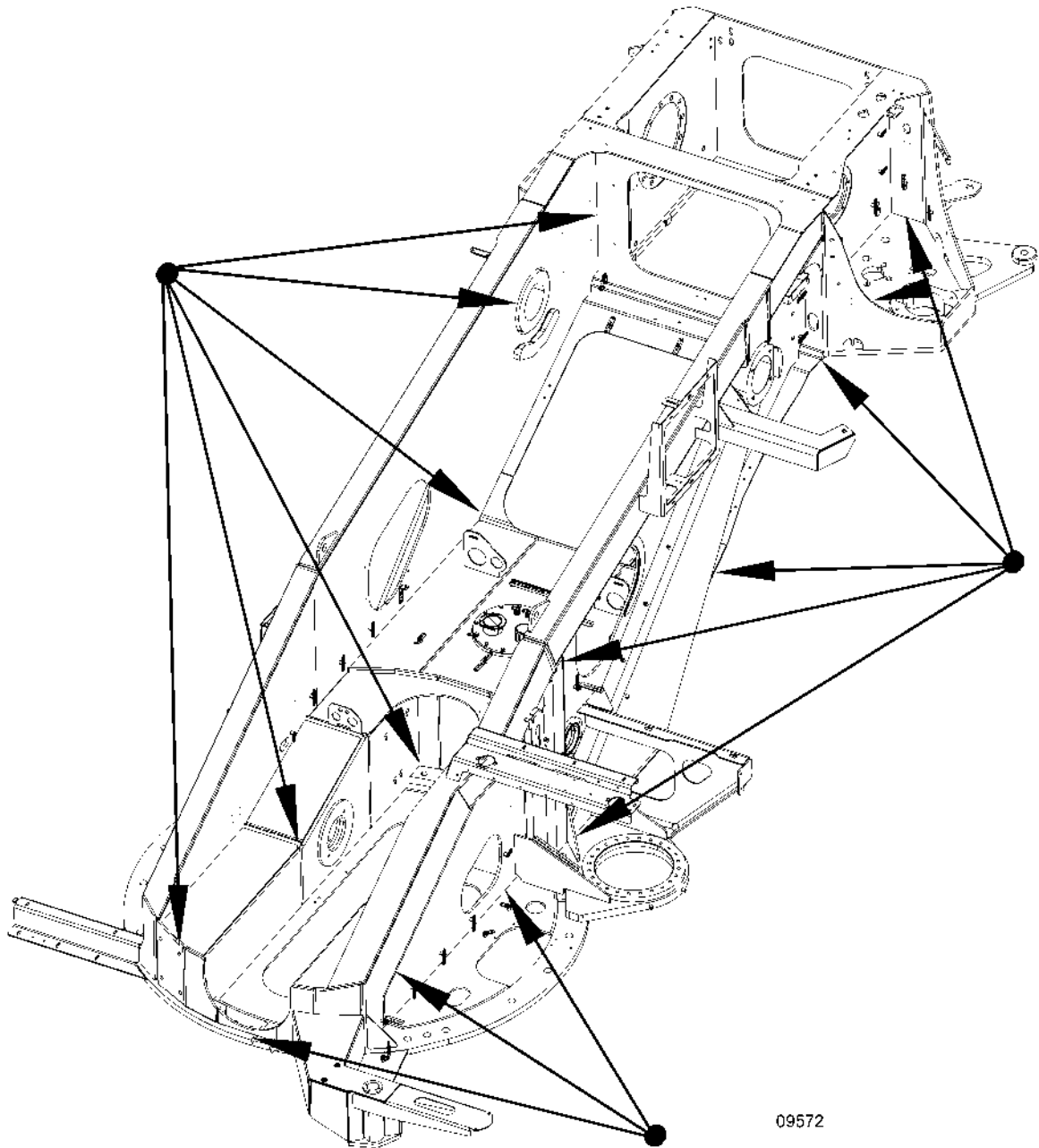

Boom

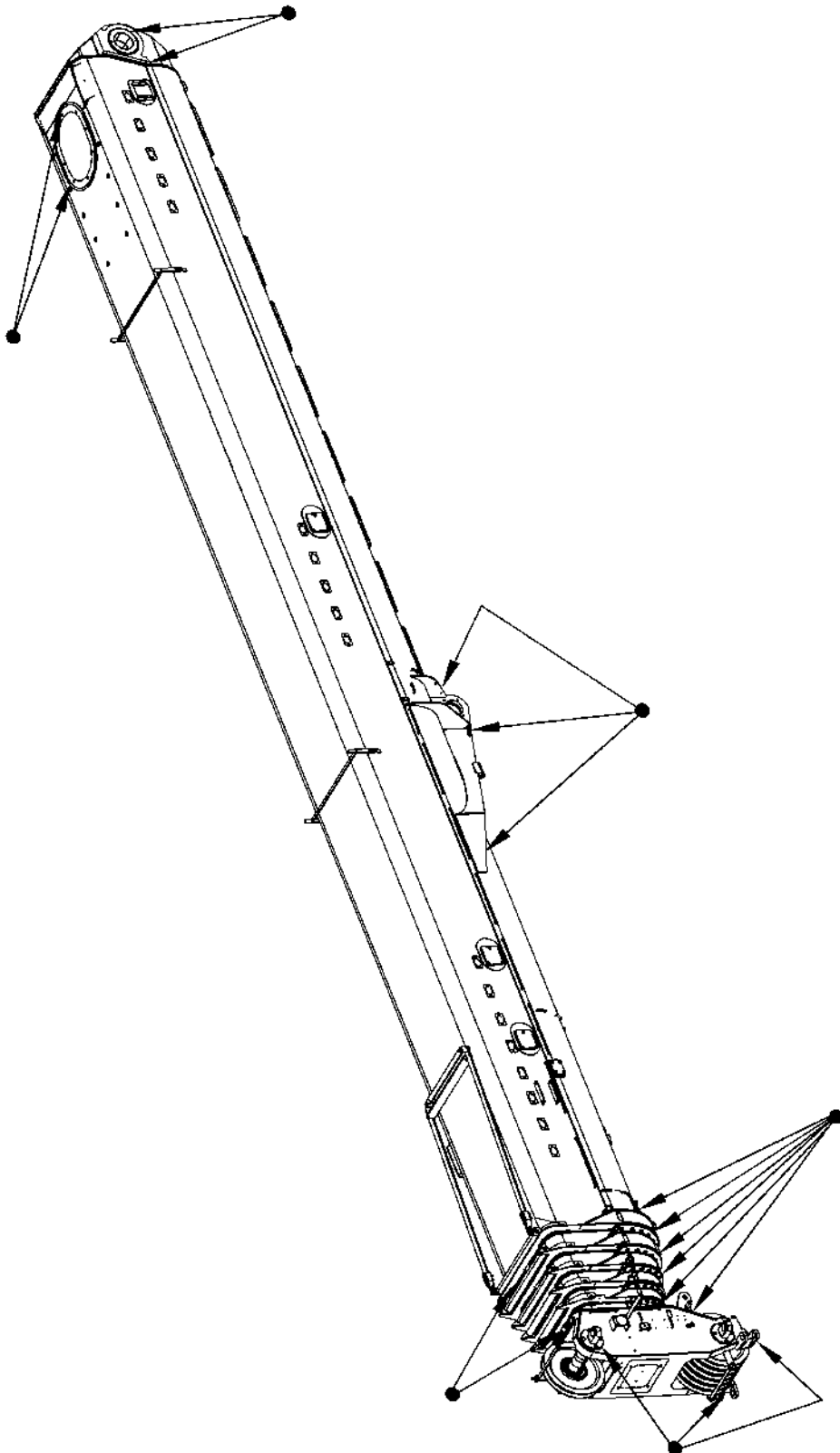

09573

Stinger\*)

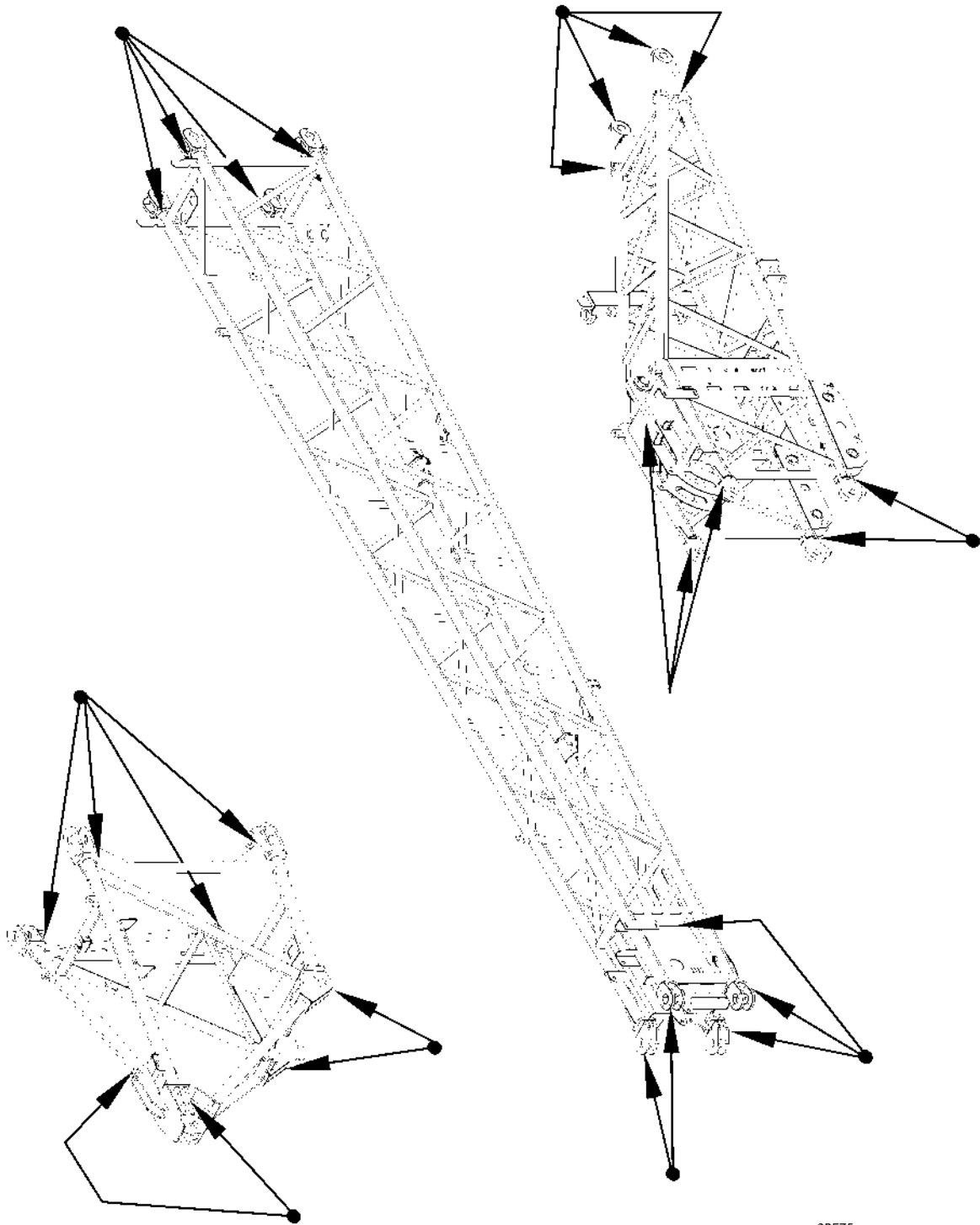

09575

Boom end\*)

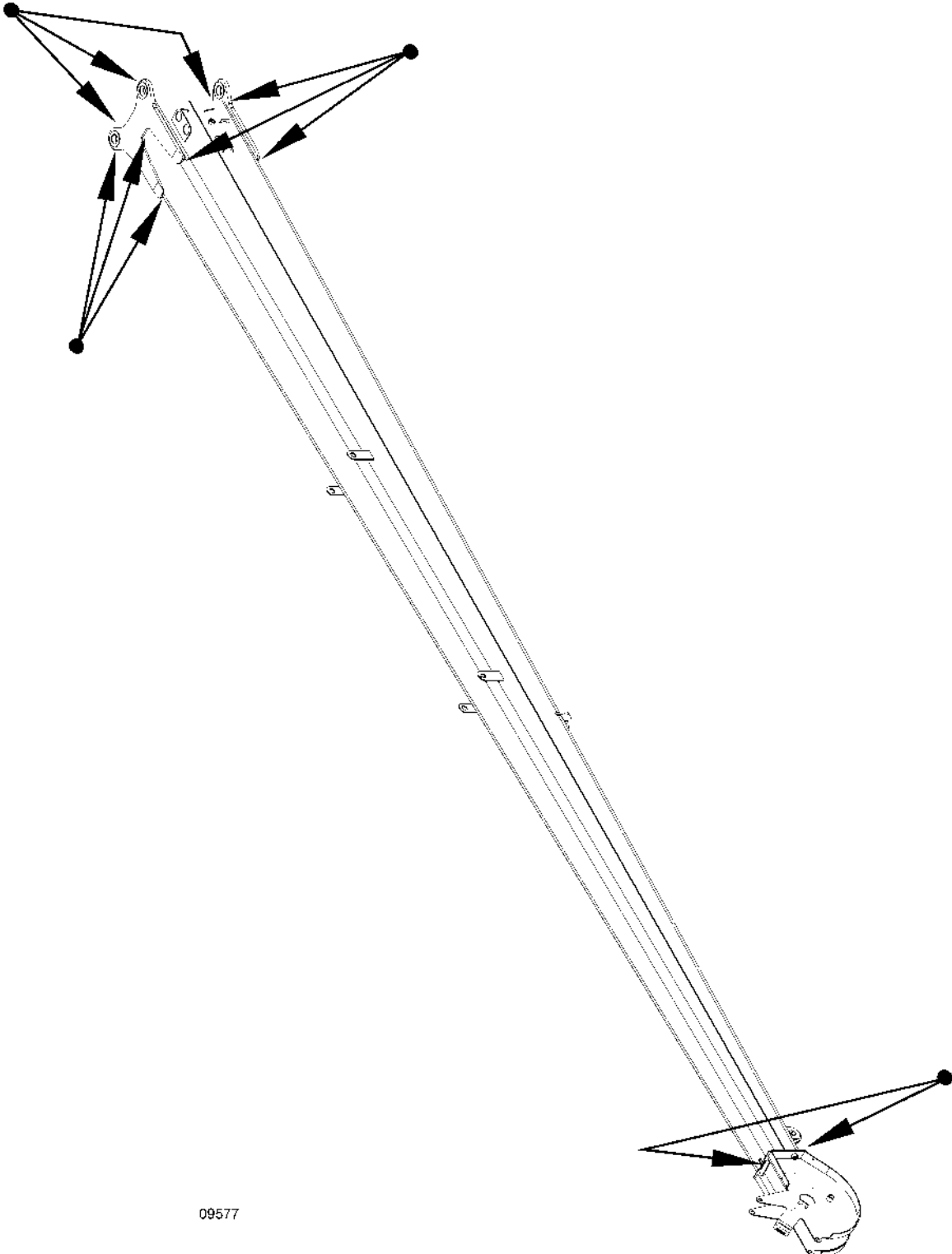

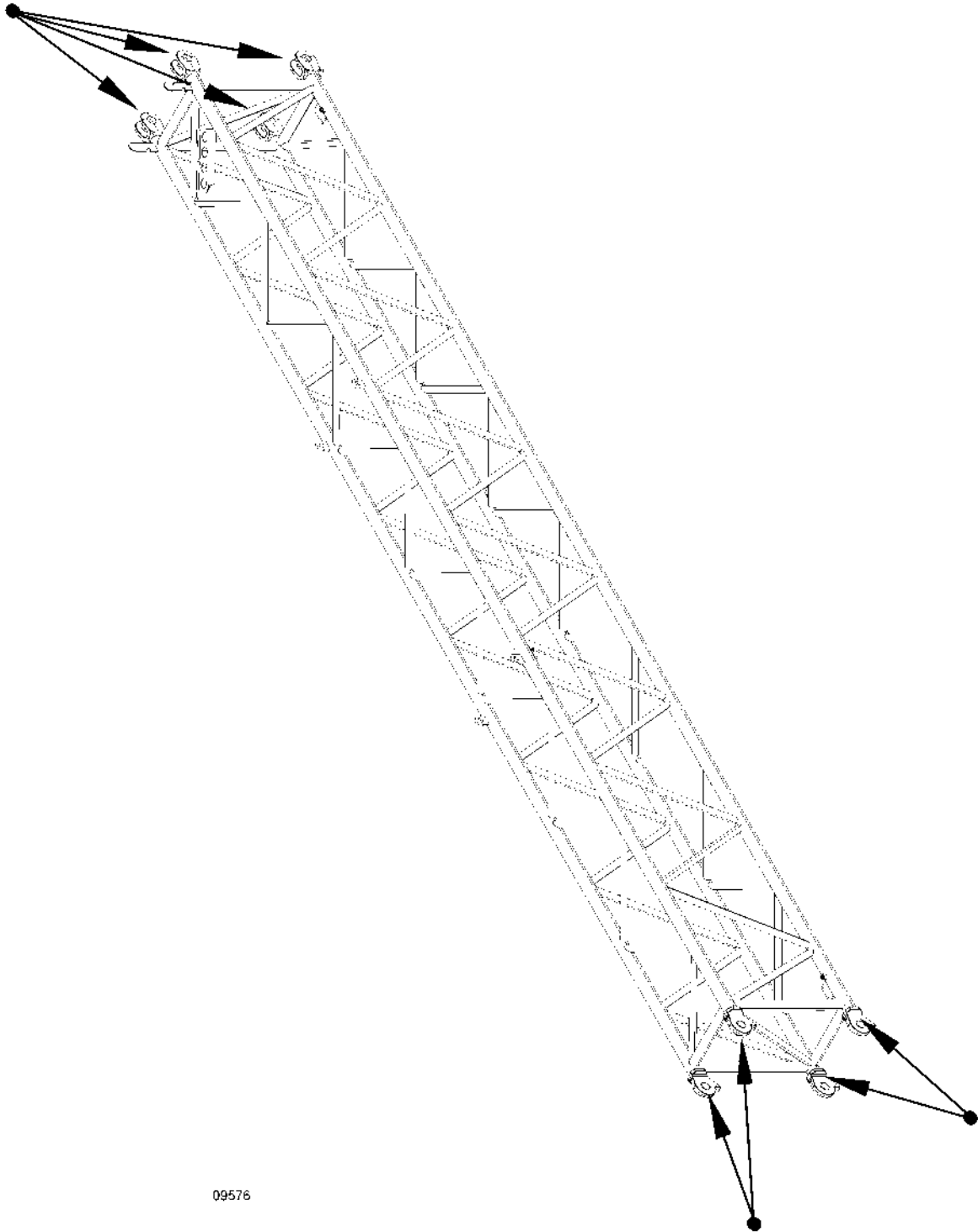

09577

Intermediate section\*)



09576

### 4.3 Checking the bottom block

	 <b>WARNING</b>
	<p><b>Crane operation with a defective bottom block</b></p> <p>If worn out or defective bottom blocks are used, the load may fall. This may result in accidents involving material damage or personal injuries.</p> <ol style="list-style-type: none"> <li>1. Operating the crane with worn-out or defective bottom blocks is prohibited.</li> </ol>

Check the bottom blocks regularly for their functionality and condition.

These checks must be conducted by experts/specialists. Prevailing national regulations and guidelines must be observed.

Please contact your TADANO After-sales Service in case of queries or problems.

It will gladly carry out all the servicing, maintenance and repair work that crops up.

An expert must check the bottom blocks and lifting hooks regularly and depending on the operating conditions of the crane. However, these checks must be conducted at least once a year. These regular checks are intended to avoid accidents due to defects.

The defects identified during the test must be documented and rectified. The rectification of defects can be confirmed through a subsequent test.

Instructions for the proper execution of the tests and the evaluation of the defects identified are given in *DIN 15405 T1*.

#### Checking for the expansion of the hook mouth

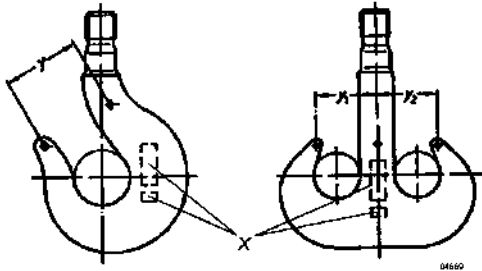
<p>X = marking Measuring section "y" or "y<sub>1</sub>" and "y<sub>2</sub>"</p>	
---	--

The check for the deformation of the hook mouth must be conducted regularly depending on the operating conditions of the crane. However, it must be conducted at least once a year.

The expansion of the hook mouth should not be more than 10% (in accordance with *DIN 15405 T1*) with respect to the original dimension "y" or "y<sub>1</sub>" and "y<sub>2</sub>". Original dimensions are specified on the lifting hooks as well as in the crane inspection log. The dimensions "y" or "y<sub>1</sub>" and "y<sub>2</sub>" are always measured between the staking punch marks.

	<p><b>! WARNING</b></p>
	<p><b>Crane operation with expanded lifting hooks</b>          If expanded lifting hooks are used, they may break and the load may fall. This may result in accidents involving material damage or personal injuries.</p> <ol style="list-style-type: none"> <li>1. Operating the crane with an expanded hook mouth is prohibited.</li> </ol>
<p><b>i</b></p>	<p><b>If a deformation is detected (even less than 10%), the lifting hook must be checked for surface cracks using suitable aids.</b></p>

### Checking for the wear

In case of single and double hooks, the wear should not be greater than 5% of the height  $h_2$  as per DIN 15401 T1 and/or DIN 15402 T1.

If the wear of the lifting hook is greater, it should no longer be used.

	<p><b>! WARNING</b></p>
	<p><b>Crane operation with a worn-out bottom block</b>          Using the worn-out bottom blocks may lead to accidents involving material damage and/or personal injuries.</p> <ol style="list-style-type: none"> <li>1. Operating the crane with the worn-out bottom block is prohibited.</li> </ol>

### Checking for corrosion



Especially the threads of the lifting hook must be checked for corrosion. Remove the lifting hook nut from the hook shaft to ensure that the threads of the lifting hook shaft are accessible for inspection.

If the lifting hook is worn out or corroded, it may not be used any longer.

	<p><b>! WARNING</b></p>
	<p><b>Crane operation with worn-out or corroded threads of the bottom block</b>          Using the bottom blocks with worn-out or corroded threads may lead to accidents involving material damage and/or personal injuries.</p> <ol style="list-style-type: none"> <li>1. Operating the crane operation with worn-out or corroded threads of the bottom block is prohibited.</li> </ol>



## 4.4 Checking the hoisting ropes

	<p style="text-align: center;"><b>! WARNING</b></p> <p><b>Crane operation with defective hoisting ropes</b></p> <p>Worn-out or defective hoisting ropes may rip or break. The load may fall. This may result in accidents involving material damage or personal injuries.</p> <ol style="list-style-type: none"> <li>1. Operating the crane with worn-out or defective hoisting ropes is prohibited.</li> </ol>
	<p style="text-align: center;"><b>! WARNING</b></p> <p><b>Maintenance work without adequate safety precautions!</b></p> <p>There is an increased risk of falling when carrying out maintenance work from an elevated place without adequate safety precautions. This may cause injuries, which could even be lethal sometimes.</p> <ol style="list-style-type: none"> <li>1. The personnel must be protected with suitable aids (e.g. platform, railing) when carrying out maintenance work on the mobile crane. Use the existing access steps and ladders.</li> </ol>

Check the condition of hoisting ropes regularly.

These checks must be conducted by experts. Prevailing national regulations and guidelines must be observed.

Please contact your TADANO After-sales Service in case of queries or problems. It will gladly carry out all the servicing, maintenance and repair work that crops up.

Rope drives of mobile cranes are not designed as high fatigue-resistant. Therefore, ropes may break during operation. Principles for monitoring the rope drives during operation are specified in *DIN 15020 T2* and ISO 4309.

Check the hoisting ropes regularly by taking into account the existing operating conditions of the mobile crane. The hoisting rope must be checked thoroughly at short intervals especially during the initial period after fixing it, after replacing it as well as in case of exceptional loads or possible damage that cannot be detected from outside.

The operational safety of the hoisting ropes being used can be evaluated as per the following criteria:

- Type and number of wire breaks
- Position and chronological order of wire breaks
- Change in the rope diameter during the operation period
- Corrosion
- Wear
- Rope deformations
- Heat effects and
- Service life.

Rope fasteners and rope attachments must be checked for the safe condition. We would like to especially specify that the wire breaks at such points are often difficult to identify. Other components of the rope drive such as rope drum or rollers must move freely in the bearings and free from defects.



### 4.4.1 Replacement state of hoisting ropes



Hoisting ropes must be replaced immediately if one of the following defects exists in the hoisting rope.

Even if there is any doubt regarding the further usability of hoisting ropes, it should always be replaced. If required, an expert of the rope manufacturer can be consulted for inspecting the hoisting rope.

	<b>If any particular defects are detected in the hoisting rope, their cause must be found and the defects must be rectified. Only then a new hoisting rope should be mounted.</b>
---	---

#### Wire breaks

	 <b>WARNING</b>
	<p><b>The hoisting rope was not checked properly after the occurrence of initial wire breaks.</b></p> <p>The number of wire breaks may increase rapidly. The hoisting rope may rip or break. The load may fall. This may result in accidents involving material damage or personal injuries.</p> <ol style="list-style-type: none"> <li>1. After the occurrence of initial wire breaks, the inspection intervals must be shortened so that the replacement condition can be identified on time.</li> </ol>

	 <b>WARNING</b>
	<p><b>Permissible number of wire breaks in the hoisting rope exceeded</b></p> <p>The hoisting rope may rip or break. The load may fall. This may result in accidents involving material damage or personal injuries.</p> <ol style="list-style-type: none"> <li>1. If the permissible number of wire breaks is reached, the hoisting rope must be replaced.</li> </ol>

A hoisting rope must be replaced at the latest when a number of visible wire breaks mentioned in the following tables is detected at any point on the hoisting rope (extract from DIN 15020 Bl.2).

Number of load-bearing wires in outer strands	Number of visible wire breaks for the replacement state at a length of	
	6 x d	30 x d
76 – 100	4	8
101 – 120	5	10
121 – 140	6	11

d – nominal diameter of the hoisting rope

National regulations which differ from the above regulations should be observed.

Determining the occurrence of wire breaks depending on the time is often recommended. The probable replacement time can then be derived from the chronological increase in wire breaks.

### Tangles of broken wires

The hoisting rope must be replaced in case of tangles of broken wires. The hoisting rope must be replaced immediately if a strand breaks.

### Reduction in diameter

The hoisting rope must be replaced when the diameter is reduced by 15% or more over a longer stretch with respect to the nominal diameter owing to structural changes.

### Corrosion

Even if wire breaks are not detected, the hoisting rope must be replaced if the rope diameter is reduced by 10% or more with respect to the nominal diameter owing to corrosion damage. Corrosion in wires that are not visible from the outside is difficult to identify.









### Wear

Even if wire breaks are not detected, the hoisting rope must be replaced if the rope diameter is reduced by 10% or more with respect to the nominal diameter owing to wear. Under the effect of wear, the static breaking strength of the hoisting rope may be reduced owing to the reduction in the metallic rope cross-section and its operational strength may also be reduced owing to wear notches.

### Rope deformations

Rope deformations are visible changes in the rope bundle of the hoisting rope. The following deformations are differentiated between depending on the appearance:

 <p>97013</p>	<ul style="list-style-type: none"> <li>▪ <b>Corkscrew-shaped deformations.</b> The hoisting rope must be replaced when a wave height of 1/3 of the rope diameter or more is available.</li> </ul>
--	---

 <p>97014</p>	<ul style="list-style-type: none"> <li>▪ <b>Baskets</b> (also called <b>bird-caging</b>) occur when the outer layer of wires is slacked or the outer strands are longer than the inner ones. Owing to movement of outer wire or strand layers with respect to the inner layers, the surplus length component is displaced to a point. The hoisting rope must be replaced in case of basket formation.</li> </ul>
 <p>97015</p>	<ul style="list-style-type: none"> <li>▪ <b>Loop formation.</b> Individual wires or wire groups come out from the rope bundle in the shape of a hairpin on the side opposite to the sheave. The hoisting rope must be replaced in case of considerable change in the rope bundle.</li> </ul>
 <p>97016</p>	<ul style="list-style-type: none"> <li>▪ <b>Slackening of individual wires or strands.</b> In this case, outer wires of the loaded wire rope or individual strands may be displaced. These strands then do not absorb the component of traction force for which they are designed. The remaining wires or strands are then overloaded. The hoisting rope must be replaced if the slackening is caused due to corrosion or wear. In case of other reasons, the resulting wire breaks are decisive for the replacement state.</li> </ul>
 <p>97017</p>	<ul style="list-style-type: none"> <li>▪ <b>Knots.</b> These are repeatedly observed bulges in the wire rope over longer rope sections. The hoisting rope is moved additionally due to knots. Hoisting ropes having severe knot formation must be replaced.</li> </ul>
 <p>97018</p>	<ul style="list-style-type: none"> <li>▪ <b>Contractions.</b> These are reductions in the diameter of the hoisting rope over short rope sections. Hoisting ropes with severe contractions must be replaced.</li> </ul>
 <p>97019</p>	<ul style="list-style-type: none"> <li>▪ <b>Flattenings.</b> These are permanent deformations in the hoisting rope that are caused due to pinching. Flattening leads to more wire breaks. Hoisting ropes with flattening must be replaced</li> </ul>
 <p>97020</p>	<ul style="list-style-type: none"> <li>▪ <b>Buckles.</b> These deformation caused when an eye-shaped grommet is pulled straight and when the hoisting rope cannot compensate the resulting deformation due to a rotary movement around its axis. Hoisting ropes with one or more buckles must be replaced.</li> </ul>
 <p>97021</p>	<ul style="list-style-type: none"> <li>▪ <b>Kinks.</b> These deformations cause due to several external effects on the wire rope. Hoisting ropes having kinks must be replaced.</li> </ul>

- **Curl-shaped deformations** are caused when the loaded hoisting rope is pulled over an edge. Hoisting ropes damaged in this manner must be replaced.

### Heat effect

Hoisting ropes exposed to an extremely high heat effect can be detected through faded colors of outer wires. Such hoisting ropes must be replaced.

### Service life

If adequate knowledge and operational experience are available for a rope drive, the time for replacing a hoisting rope can be determined for a mobile crane within the scope of a preventive maintenance provided the operating conditions and the hoisting rope remain the same.

The hoisting rope must be checked regularly.

#### 4.4.2 Replacing a hoisting rope

	<p><b>! WARNING</b></p>
	<p><b>Incorrect hoisting rope has been fixed.</b></p> <p>An incorrect hoisting rope may rip, break or cause damage to the rope drive of the mobile crane. The load may fall. This may result in accidents involving material damage or personal injuries.</p> <p>1. When laying a new hoisting rope, only use a hoisting rope having the same strength, the make and the nominal diameter as that of the original hoisting rope when it was new.</p> <p>⇒ If other rope type is to be used, a prior written consent of TADANO is essential.</p>

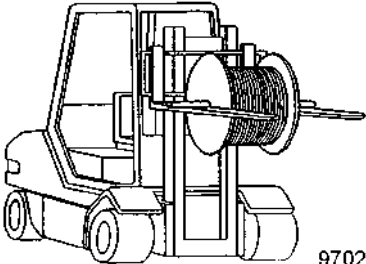
 <p style="text-align: right; margin-right: 10px;">97022</p>	<p>Utmost care must be taken when unloading, transporting and storing the hoisting ropes. The hoisting rope must be protected against mechanical damage due to fork-lift truck prongs or lifting hooks when unloading and transporting.</p>
---	---

Hoisting ropes stored as reserve must be stored in a clean, cool, dry and covered room such that they do not come in contact with the ground, e.g. on pallets.

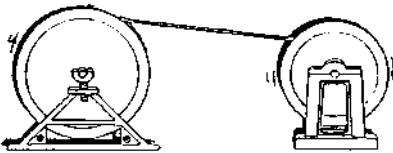
 <p style="text-align: right; margin-right: 10px;">97023</p>	<p>When mounting a new hoisting rope, it must be implicitly ensured that the new hoisting rope is wound up on the winch without twists and damage. It is most practical to use a rotary disc or a rack for winding up a hoisting rope delivered in the ring or on a winch.</p> <p>When winding from the winch to the drum, it must be ensured that the same bending direction is maintained for the hoisting rope.</p>
---	--

Rope windings should never be pulled sideways from the ring or the winch since this may lead to twists in the hoisting rope.

<b>i</b>	During the mounting process, the new hoisting rope should not be pulled over the ground. Sticky dirt and sand on the rope lubricant may damage the hoisting rope in the system between the sheave and the hoisting rope.
----------	--

For a flawless winding of the hoisting rope especially in case of a multi-layer winding, on the rope drum, it is very important that the new hoisting rope is pulled up with a pre-tension of approximately 1% to 2% of the minimum breaking strength of the hoisting rope. If the lower layers on the rope drum are too slackened, the upper rope layers may get jammed in the slackened lower rope windings when they are exposed to loads. This may cause severe damage to the rope.

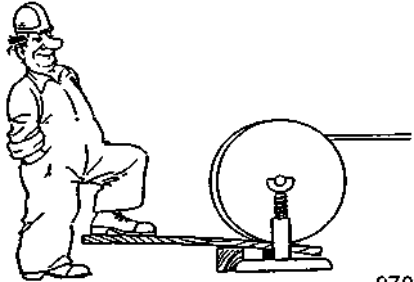
 <p style="text-align: right;">97027</p>	The pre-tension should be generated by braking the winch flange using a plank,
---	--

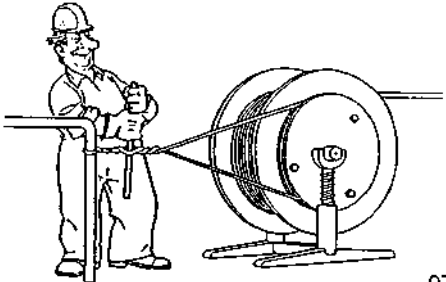
 <p style="text-align: right;">97028</p>	or a brake disc with brake strings fixed on the winch.
--	--

After mounting the new hoisting rope successfully, it must first be retracted with small partial loads. This will set the hoisting rope and align it with the bending direction and bending radii of rope drum and rollers in a better manner.

### 4.4.3 Maintenance and repair of the hoisting rope

In accordance with *DIN 15020 Bl. 2* and *ISO 4309*, hoisting ropes must be maintained regularly depending on operating conditions. Regular maintenance can help in increasing the service life of a hoisting rope considerably.

Hoisting ropes must be re-lubricated at regular intervals depending on the operating conditions. Well-lubricated hoisting ropes can withstand a higher number of curvature changes and thus result in a considerably longer service life.



<b>i</b>	When selecting the new lubricant, it must be ensured that it is compatible with the original lubricant of the rope manufacturer.
----------	--

Severely contaminated hoisting ropes must be cleaned. Brushes are best suited for cleaning in this case.

It is often essential to replace the hoisting ropes that are damaged only over relatively short rope sections that are exposed to high stresses, e.g. in the area where the hoisting rope switches over from the first layer to the second, even if the remaining rope length is still in the good condition. The service life of a hoisting rope can be increased by shortening the hoisting rope by a suitable section in the hoisting gear such that the rope section exposed to high stresses comes in an area with lower stresses.

**Further information:** see the Hoisting rope point in the Maintenance and repair of superstructure section.

## 4.5 Service life of the hoisting gear

	 <b>WARNING</b>
	<p><b>Crane operation with defective hoisting gear</b></p> <p>If the crane is operated with a defective hoisting gear, the load may fall. This may result in accidents involving material damage or personal injuries.</p> <p>1. Operating the crane with a defective hoisting gear is prohibited.</p>

Check the hoisting gears regularly for their functionality and condition.

These checks must be conducted by experts or specialists. Prevailing national regulations and guidelines must be observed.

Please contact your TADANO After-sales Service in case of queries or problems. It will gladly carry out all the servicing, maintenance and repair work that crops up.

## 4.6 Monitoring the slewing ring

### 4.6.1 Checking the turntable fixing screws

The fixing screws of the ball-bearing slewing ring may need to be re-tightened owing to settling phenomena. The prescribed tightening torques are specified in the operating manual (see Maintenance and repair of superstructure, chapter C 4.10).

Fixing screws must be checked for the first time after approximately 100 operating hours. Turntable screws must be checked at regular intervals depending on the actual operating conditions of the mobile crane. They must however be checked at least after every 500 operating hours.

If the mobile crane is subjected to an impermissible load when operating (e.g. a high impact load due to a load falling on the hoisting rope or similar), the turntable screws and other load-bearing parts of the mobile crane must be checked.





## 5 Rectifying the faults

### 5.1 Rectifying the faults

The following table will help you in quickly finding the cause in case of a failure of or a fault in a specific function of the device and also in rectifying the same.

A troubleshooting table does not replace an expert. If the cause of a fault cannot be identified or rectified using the table, please contact our TADANO After-sales Service.

### 5.1.1 Engine

Engine-specific faults and their remedy are given in the operating manual of the engine manufacturer.

Fault	Possible cause	Rectification
The superstructure cannot be started. (For other possible causes, see the Electrical equipment section.)	Air in the fuel system.	Bleeding the fuel system
	No electrical connection between the battery and the consumer.	The main switch of the battery is not switched on. Press the switch in the superstructure instrument panel.
	The switch in the superstructure (OW) is at an incorrect switch position.	Toggle the switch.
	The ignition starter switch is defective or the electrical plug connection is loose.	Replace the switch. Check the plug connections.
The engine is running irregularly or the power is too less.	The air cleaner is contaminated.	Change the filter inserts, clean the filter head. (follow the maintenance indicator)
	Air-inlet pipes are leaky.	Check the inlet system for leak tightness. Tighten the hose clamps.
	The function of the injection system is defective.	Get it checked in a specialist workshop.
Excessive coolant temperature even if the engine is not loaded (indicator on the CGC display lights up).	Cooler fins are contaminated or the V-belts of the fan are ripped.	Clean the fins or blow out using compressed air; replace V-belts if required.
	Cooling system is leaky.	Check the system for leak tightness.
Coolant level is too low (indicator on the CGC display lights up).	Cooling water hose connections are leaky.	Tighten the hose clamps.
	The pressure relief valve of the expansion tank is defective.	Check the functioning of the pressure relief valve and replace it if required.
	Porous cooling water hoses.	Replace all hoses.
	Drain plug loosened or leaky.	Tighten the drain plug and replace the sealing tape if required.
		Fill the remaining volume of cooling water.
The engine cannot be stopped.	Electrical connections are loose or the switch is defective.	Insert the cable lugs or replace the switch.

#### See also

 Electrical system [→ 490]

## 5.1.2 Superstructure hydraulic system - general

Fault	Possible cause	Rectification
The hydraulic system does not deliver the complete output.	Air in the system.	Bleed the hydraulic system.
	Pilot pressure is too low (control oil supply).	Pressure limiting valve: Check the pressure setting and reset it if required. Check the pressure at the measuring connection.
	The pump control signal is not available or is only partially available.	Measure the current of the pump controller.
	The pressure limiting setting is not correct.	Check the pressure and reset it if required.
	The replenishing valve is contaminated.	Clean the valve.
	The pump controller or hydraulic pumps are defective.	Check the pumps and the controller setting and repair them if required.
	The oil viscosity is incorrect.	Fill in the prescribed oil depending on the ambient temperature.
Excessive noises of hydraulic pumps.	Hydraulic pumps are sucking air.	Stop the hydraulic pumps immediately. Check the leak tightness and the oil level of the hydraulic system and top up oil if required.
	Hydraulic pumps are defective.	Repair or replace the hydraulic pumps.
	The stopcock is closed.	Open the stopcock.
The superstructure hydraulic system is not functioning.	The left is not folded down completely.	Fold-down the armrest to release the switch functions.
	The switch is defective.	Replace the switch.
	Hydraulic pumps are defective.	Repair or replace the hydraulic pumps.
	The mechanical connection with the pumps has loosened.	Check the screw joints.
	AML switch off.	Select the correct AML program.
	The pilot signal is missing.	Check the control unit.
Hydraulic oil temperature is too high.	The oil cooler is contaminated. (For other possible causes, see the Electrical system section.)	Clean the oil cooler.

### 5.1.3 Swing mechanism

Fault	Possible cause	Rectification
The swing mechanism moves very slowly.	Control oil pressure is too low.	Check the pressure at the test connection.
	The crane control lever is defective.	Replace the crane control lever.
	The axial piston engine is defective.	Repair or replace it.
	The swing mechanism pump is defective.	Repair or replace it.
	The pump control valve is defective.	Replace the valve.
The swing mechanism slews only in one direction.	The crane control lever is defective.	Replace the crane control lever.
	The non-return valve in the 3-stage control unit is defective.	Replace the valve.
The swing mechanism cannot be braked.	Discs are worn out.	Replace the complete disc set.
	The solenoid valve is defective.	Replace the solenoid valve.
The swing mechanism does not function even after actuating the crane control lever.	The brake does not open.	Check the hydraulic pressure.
	The crane control lever is defective.	Replace the crane control lever.
The "Swing mechanism locked" pilot lamp does not light up even if the superstructure lock is actuated.	Proximity switch in the carrier is defective.	Replace the proximity switch.
The slewing gear brake cannot be released.	Hydraulic pressure is too low.	Check the pressure at the test connection.

### 5.1.4 Telescoping system

Fault	Possible cause	Rectification
The boom extends and retracts in a jerky motion.	No lubrication of the boom sliding surfaces and slide coverings.	Lubricate as per the greasing chart, reset the slide coverings or replace them if required.
	Air in the cylinder.	Bleed the cylinder.
The telescope section does not extend or retract any longer.	Fuses of the tele-control are defective.	Replace the fuses.
	The relay of the tele-control is defective.	Replace the relay
	The solenoid valve is defective.	Replace the solenoid valve (see electric circuit diagrams).
No fast run while extending.	The fast run valve in the valve block is defective.	Replace the valve.
	The switch in the crane control lever is defective.	Replace the switch.

## 5.1.5 Derrick

Fault	Possible cause	Rectification
The derrick cylinder sinks.	Air in the cylinder.	Bleed the cylinder.
	The brake valve is defective.	Replace the valve.
The upward and downward derrick movements are very slow.	Control pressure is too low.	Reset the control pressure.
	The control piston in the 2-stage control unit is defective.	Replace the valve.
	The brake valve is defective.	Replace the brake valve.
	The sintered filter in the brake valve is clogged.	Replace the filter.
The derrick cannot be lowered.	The brake valve is defective.	Replace the valve.
	The pressure limiting valve is defective.	Replace the valve.
	The sintered filter is clogged.	Replace the filter.
No fast run while raising.	The fast run valve in the valve block is defective.	Replace the valve.
	The switch in the crane control lever is defective.	Replace the switch.

## 5.1.6 Hoisting gear

Fault	Possible cause	Rectification
The load is lowered slowly or in a jerky motion when the hand control lever is set to the middle position.	The hydro-multi-disc brake is worn out.	Replace the complete disc set.
	The free run is defective.	Replace the free run.
The hoisting gear turns very slowly.	Control oil pressure is too low.	Check the pressure at the test connection.
	The sintered filter is contaminated.	Replace the filter.
The hoisting gear is too slow while lowering.	The replenishing valve is leaky.	Replace the valve.
The hoisting gear does not function.	AML has switched off.	Re-actuate the AML.
	The anti-twoblock device is switched off or is defective.	Release the cylinder and/or replace the switch.
	The crane control lever is defective.	Replace the crane control lever.
	The valve in the 1-stage control unit is defective.	Replace the valve.
	The hoist gear motor is defective.	Replace the hoist gear motor.
No fast run.	The fast run valve in the valve block is defective.	Replace the valve.
	The fast run valve in the valve block is defective.	Replace the switch.

### 5.1.7 Counterweight

Fault	Possible cause	Rectification
Weights automatically lower slowly.	The counterweight cylinder is leaky.	Replace the cylinder seals and replace the cylinder if required.
	Air in the cylinder.	Bleed the cylinder.
	The load retaining valve is defective.	Replace the valve.
Weights cannot be locked or unlocked.	The valve in the 3-stage control unit is defective.	Replace the valve.
	The slew motor of the cylinder is defective.	Replace the slew motor.
	Counterweight cylinders are not extended completely.	Extend the cylinders completely; the pilot lamp must remain lit up.
Counterweight cylinders lower unevenly.	The nozzle in the flow divider is clogged.	Clean the nozzle.
Weights cannot be lowered or lifted.	The valve in the 3-stage control unit is defective.	Replace the valve.
Counterweight cylinders are retracted or extended very slowly.	Hydraulic pressure is too low.	Check the pressure at the measuring connection.
	Pilot pressure is too low.	Check the pressure at the measuring connection.

### 5.1.8 Electrical system

Fault	Possible cause	Rectification
No current when the ignition is switched on.	No connection between the earth and the battery.	Switch on the battery main switch.
	The battery relay is defective or the cables are loose.	Replace the battery relay and/or fix the cables.
	The ground strap is loose.	Tighten the strap.
The superstructure engine cannot be started.	The fuse is defective.	Replace the fuse.
	The starter is defective.	Repair or replace the starter.
	The ignition starter switch is defective.	Replace the switch.
Hydraulic oil temperature is too high (the symbol on the CGC display lights up).	The temperature switch of the cooler motor is defective.	Replace the switch.
	The cooler controller relay is defective.	Replace the relay (also see the Relay chart, chapter C Maintenance and repair of superstructure).
	The cooler motor or the fuse is defective.	Replace the motor or the fuse (also see Fuses, chapter C Maintenance and repair of superstructure).

### 5.1.9 Wiring diagram

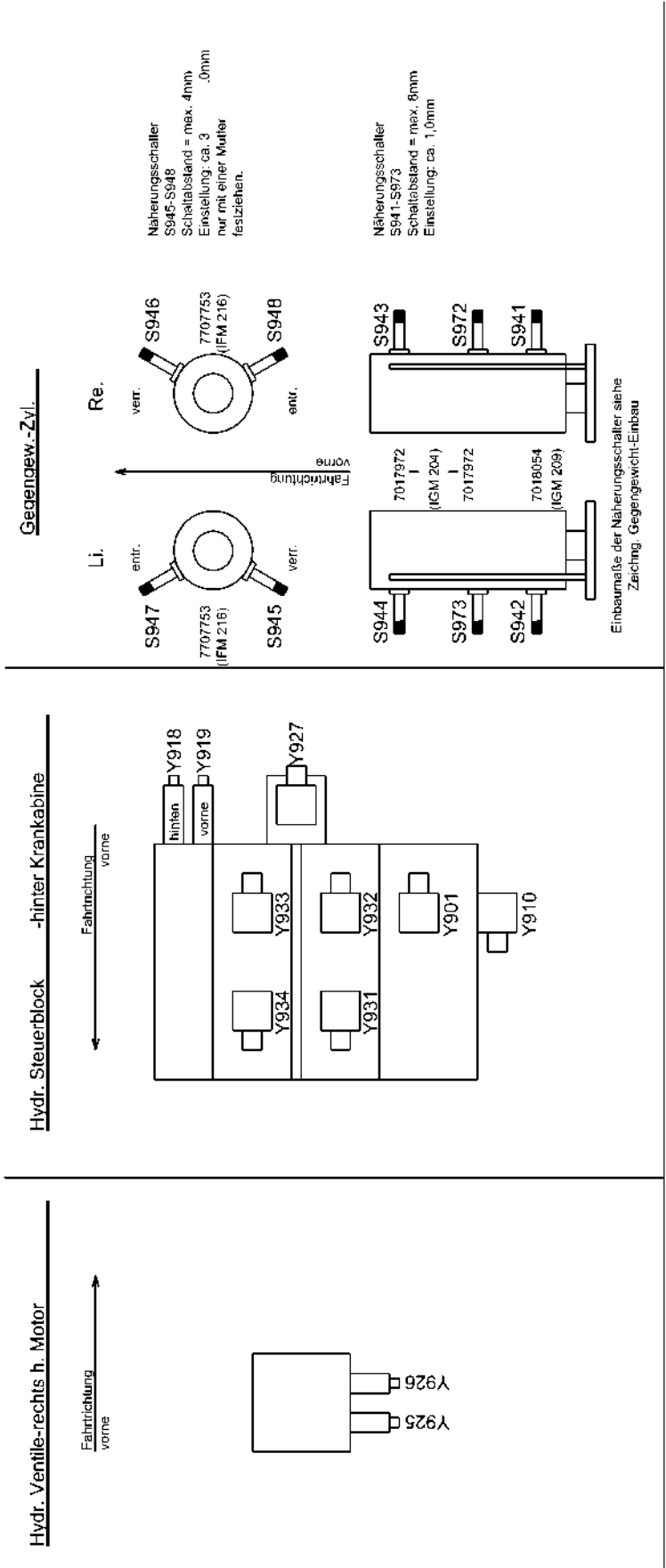

99707707762\_01  
 A/0809



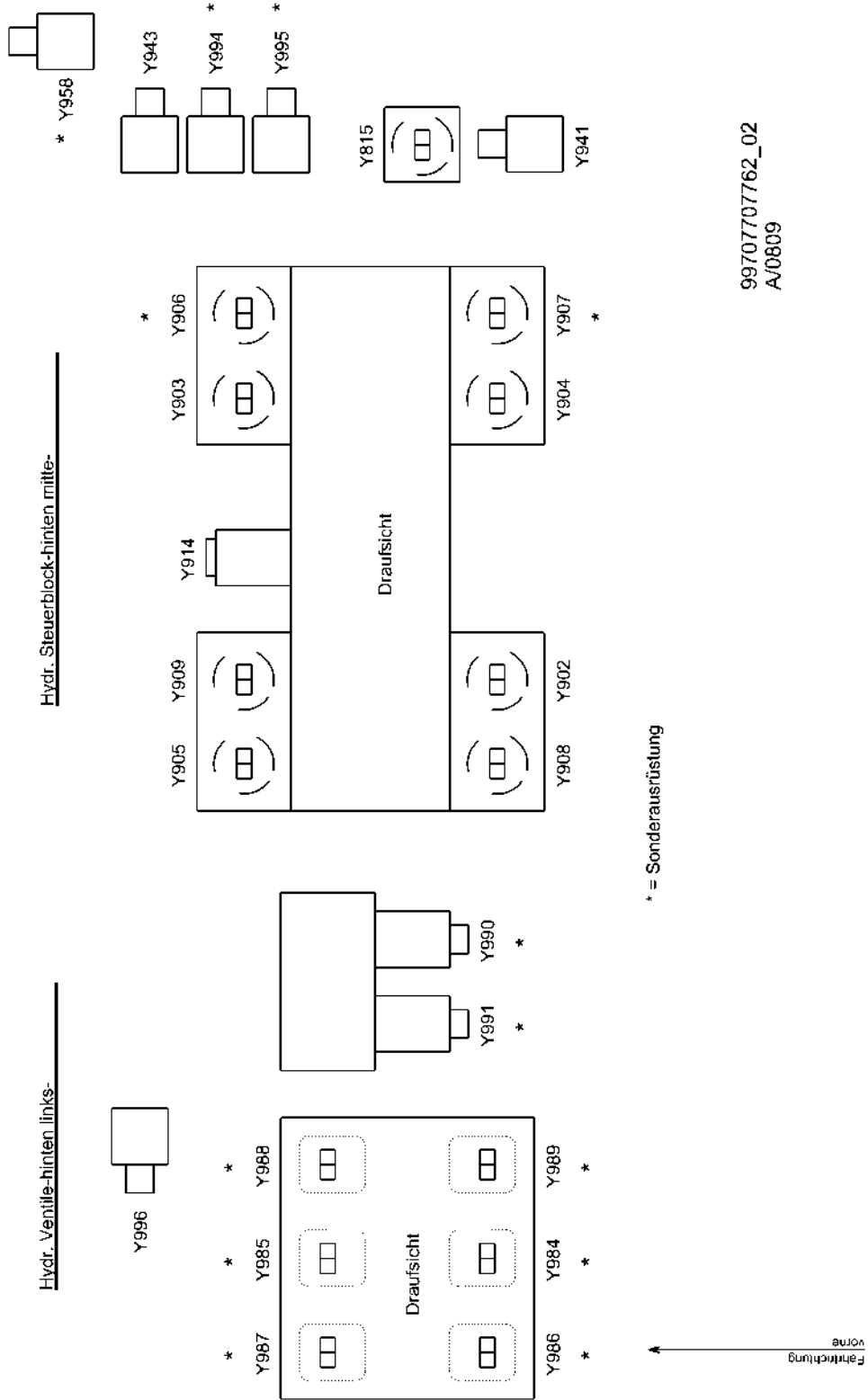

99707707762\_02  
A/0809

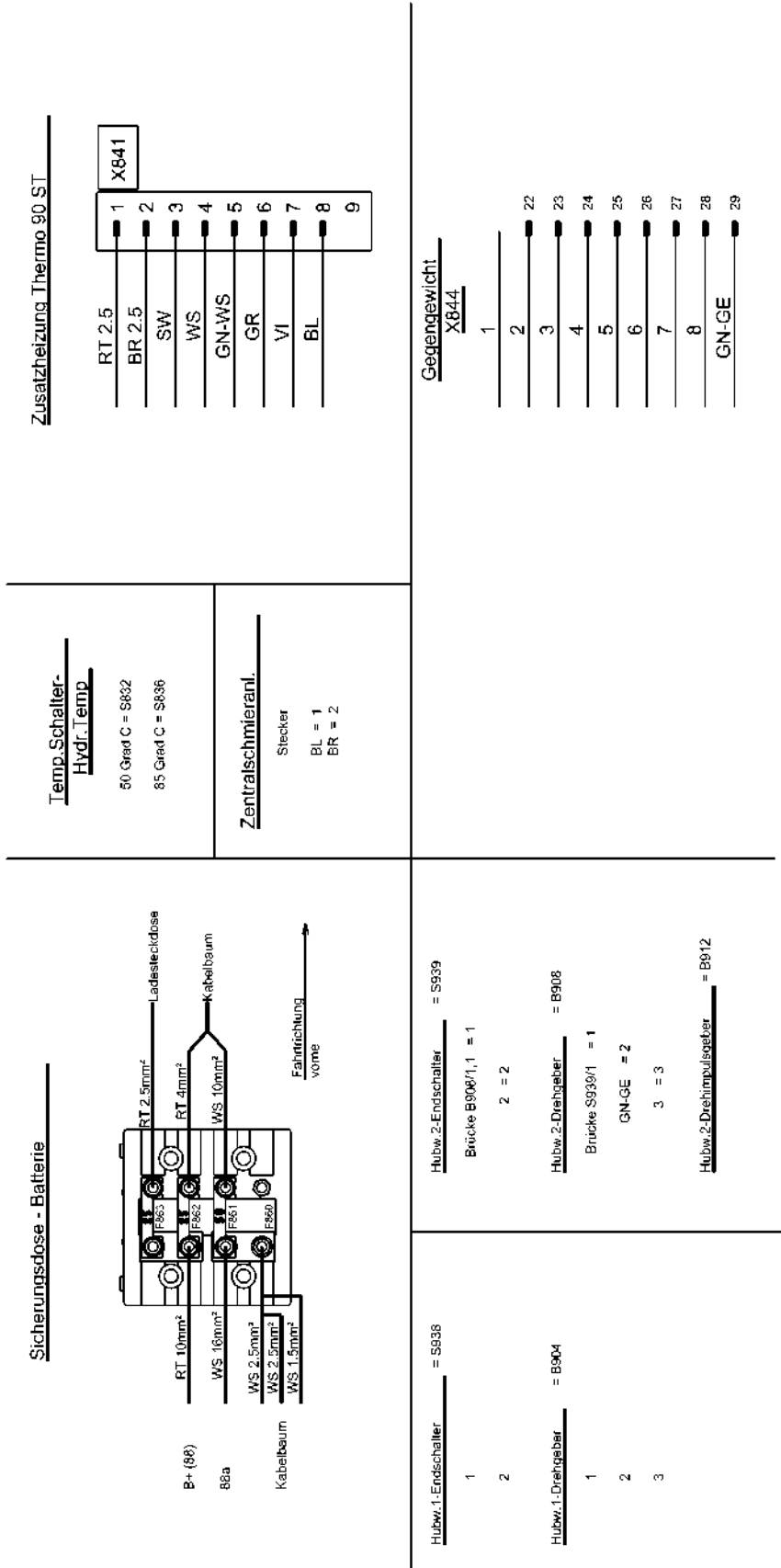

## 6 Technical Specifications

### 6.1 Engine

Number of cylinders:	4
Exhaust system:	Stainless steel with integrated spark arrester
Manufacturer:	Mercedes-Benz
Displacement:	4.8 l (1.3 gal)
Fuel tank:	220 l (58.1 gal)
AdBlue® tank	8 l (2.1 gal), incl. fill level sensor and tank heater
Cooling unit:	Water-cooled, hydrostatically driven fan with electronic control.
Power:	127 kW (173 HP) at 2,000 rpm
Maximum torque:	675 Nm at 1,200 rpm to 1,600 rpm
Type:	OM924LA
Certification:	EUROMOT III B or EPA Tier4i
Exhaust gas aftertreatment:	SCR system, exhaust silencer with catalytic converter and NOx sensor, AdBlue® injection with supply and dosing unit. Catalytic converter and exhaust pipework made from stainless steel.

#### Noise level with engine under load and at working speed (1,500 rpm)

Noise level with superstructure cab closed (at driver's ear)	Noise level with superstructure cab open (at driver's ear)	Noise at 7 m (23.0 ft) distance
73 dB(A)	77 dB(A)	73 dB(A)

From 01.01.2002: 2000/14/EC

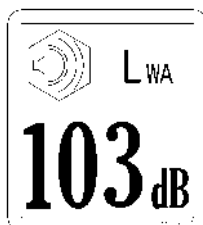

### 6.2 Hydraulic system

Diesel-hydraulic with 3-circuit hydraulics, oil cooler, 1 power-regulated axial piston double pump (electrically adjustable) with summation circuit for telescoping, luffing and hoisting gear, 1 axial piston pump for slewing gear and 2 gear pumps for control-fluid supply and remote locking.

#### Hydraulic control

Two 4-way control levers and electric pilot-operated control units that enable simultaneous, but independent crane movements and infinitely variable speed control.

### 6.3 Hoisting gear

Axial piston motor, winch drum with integrated planetary transmission and hydraulically operated spring-loaded multiple-disc brake with integrated free wheel mechanism for hoisting. The hoisting gear is driven in an open fluid circuit, drum rotation indicator, hoisting rope with SUPER-STOP rope clamp.

		Hoisting gear 1	Hoisting gear 2*)
Drum diameter	mm (in)	525 (20.7)	525 (20.7)
Rope diameter	mm (in)	21 (0.8)	21 (0.8)
Rope length, approx.	m (ft)	250 (820.2)	250 (820.2)
Max. rope tension	kN	approx. 85	approx. 85
Max. rope speed	m/min (ft/min)	76 (249.3), fast-approach mode 130 (426.5)	76 (249.3), fast-approach mode 130 (426.5)

### 6.4 Telescopic boom

Six-section telescopic boom made from high-strength, fine-grain steel, consisting of a base boom and 5 telescopic sections with a telescope cylinder for extending and retracting the telescopes. The telescopes are extended and retracted fully automatically and are locked in their respective working positions fully automatically. The telescopes can be telescoped hydraulically under a partial load.

Overall length	Retracted	m (ft)	12.8 (42.0)
Overall length	Extended	m (ft)	60.0 (196.9)
Max. pulley height		m (ft)	63.0 (206.7)
Telescoping time	12.8 m (42.0 ft) to 60.0 m (196.9 ft)	s	approx. 380

### 6.5 Boom luffing gear

Differential cylinder with integral brake and holding valve. Slow-stop function.

Adjusting angle	°	-1° to +82.7°
Adjusting time	s	84 s / fast-approach mode 42 s (luffing up only)

### 6.6 Swing mechanism

Axial piston constant motor, three-stage planetary transmission with foot-operated or automatic service brake and parking brake. Open hydraulic circuit with slewing gear release. Slewing speed, infinitely variable from 0 – 1.6 rpm.

## 6.7 Safety equipment

Electronic automatic safe load indicator, with switch-off function in the event of an overload, warning, overload warning, capacity utilisation display, and safety working range function.

Digital displays for working radius, load currently suspended and maximum permissible load, tare display, boom length, boom angle, pulley-head height, hook travel. Hoisting limiter for highest hook position. Safety working range functions for telescopic boom angle and pulley-head height, working radius, and slewing range limit. Further displays for e.g. outrigger base, counterweight, wind speed, rope fall, fly jib length and angle, lights for anti-twoblock device. VGA screen for displaying: Telescoping sequence selection, telescoping state, telescoping target, telescoping cylinder length, service information, and system diagnostics functions showing fault/warning messages and fault history.

Speed of movements can be selected by the operator. Slow-stop function for slewing and luffing.

Lift-adjuster function to ensure the load is lifted without swinging (automatic luffing up of the boom to maintain a constant working radius).

Anti-twoblock device, anemometer on main-boom pulley head, can be removed and attached to the pulley head of the jib.

Safety valves against pipe and hose ruptures, lower limit switch for safety rope windings on the lifting drum.

## 6.8 Electrical system

24 Volt DC system with 80 Ampere three-phase light machine, 2 batteries with 12 Volt 110 Ah each,

1 rotary beacon at the rear left of the rotary platform next to the hoisting gear, 2 working floodlights integrated into the superstructure cab, 2 side lights on the boom head.

## 6.9 Superstructure cab

Crane cab (generously dimensioned and ergonomic) made from steel and plastic, with sliding door, safety glazing with tinted panels, hinged windscreen, firmly bonded roof panel made from bullet-proof glass, and hinged rear window. Sliding side access plate driven by motor.

For optimum visibility during crane operation, the work station can be tilted using the infinitely variable tilting technology integrated in the cab. It is equipped with an adjustable, hydraulically damped driver's seat with headrest, mechanically adjustable lumbar support, seat heating, washer and wiper system for windscreen and roof panel, windscreen wipers with intermittent wipe, hourmeter, sun visor, signal horn, radio/CD player, 24 V and 12 V socket, cup holder.

Display for checking e.g. fuel level and AdBlue supply, hydraulic fluid temperature, on-board voltage, superstructure lock, and for monitoring the engine.

Air conditioning system.

Engine-dependent hot water heating and engine-independent auxiliary heater with engine pre-heating (Webasto Thermo 90ST hot-water heating), diesel-driven. The Webasto Thermo 90ST engine-independent auxiliary heater is not suitable for bio-diesel.

The outriggers and engine functions for the carrier can be operated from the superstructure cab. Single-key system for the driver's cab and crane cab doors, tank locks in the superstructure and carrier, and the steering wheel lock.

### Vibration values in the crane cab during crane operations

In normal operations, the measured vibration values never exceed the limit value of  $0.5 \text{ m/s}^2$  ( $1.6 \text{ ft/s}^2$ ) specified in the Machinery Directive (98/37/EC).

## 6.10 Counterweight

Counterweight 42.3 t (93,255.5 lbs), separable. The counterweight section can be stored with the hydraulic cylinders. Operation is from the crane cab.

The slewing radius is 4.2 m (13.8 ft); ASLI programming for 3.9 t / 6.3 t / 9.4 t / 31.7 t / 42.0 t (8,598.0 lbs / 13,889.1 lbs / 20,723.5 lbs / 69,886.5 lbs / 92,594.2 lbs) counterweight.

The vehicle width is not exceeded for counterweights up to and including 31.7 t (69,886.5 lbs). The vehicle is technically able to transport 21.7 t (47,840.3 lbs).

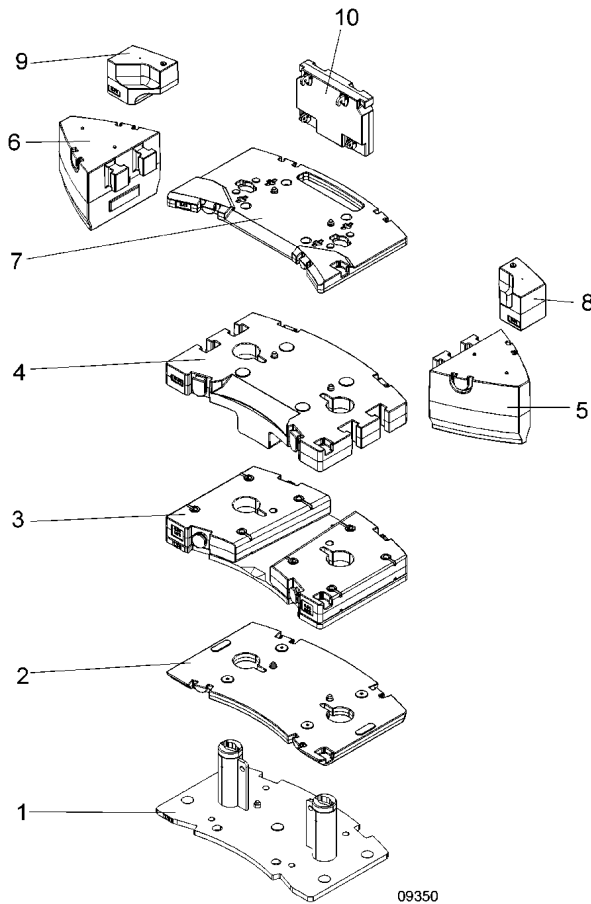

1	Base plate 2.4 t (5,291.1 lbs)	6	Counterweight 5.3 t (11,684.5 lbs)
2	Counterweight 3.4 t (7,495.7 lbs)	7	Counterweight 3.1 t (6,834.3 lbs)
3	Counterweight 8.9 t (19,621.1 lbs)	8	Counterweight 1.2 t (2,645.6 lbs)
4	Counterweight 10.0 t (22,046.2 lbs)	9	Counterweight 1.2 t (2,645.6 lbs)
5	Counterweight 5.3 t (11,684.5 lbs)	10	Counterweight 1.5 t (3,306.9 lbs)

For information about the weight distribution for the axle loads and set-up conditions, see Weights in Technical Specifications for the carrier.

## 6.11 Superstructure frame

Torsion-resistant welded construction with an externally-toothed, single-row ball-bearing slewing ring, freely rotatable through 360°.

Centralised lubrication system for ball-bearing slewing ring, luffing cylinder (head and foot) and boom foot point bearing, and for the main and auxiliary winch.

Storage space behind the cab.

### 6.12 Optional equipment

- Jib (three sections), 3.8 m/10.2 m/18 m (12.5 ft/33.5 ft/59.1 ft), can be angled to 0°/20°/40°, with extension of the automatic safe load indicator, anti-twoblock device and ladder for fitting the jib. The jib is folded sideways against the base boom for transport purposes. The 3.8 m (12.5 ft) base section and 10.2 m (33.5 ft) section can each be folded separately into their working position.
- Jib (three sections), 3.8 m/10.2 m/18 m (12.5 ft/33.5 ft/59.1 ft), can be hydraulically angled to 0°-40°, with extension of the automatic safe load indicator, anti-twoblock device and ladder for fitting the jib. The jib is folded sideways against the base boom for transport purposes. The 3.8 m (12.5 ft) base section and 10.2 m (33.5 ft) section can each be folded separately into their working position.
- 1 intermediate section (7 m (23.0 ft)), for increasing to 25 m (82.0 ft) with extension of the automatic safe load indicator. The intermediate section is attached using pins in front of the 3.8 m (12.5 ft).
- 2 intermediate sections (each 7 m (23.0 ft)), for increasing to 32 m (105.0 ft) with extension of the automatic safe load indicator. The intermediate sections are attached using pins in front of the 3.8 m (12.5 ft) jib.
- Single top.
- Extension of the automatic safe load indicator for 12.8 t (14.1 tn. sh.) counterweight.
- Extension of the automatic safe load indicator for 21.7 t (23.9 tn. sh.) counterweight.
- Supporting force display in the superstructure cab and the control boxes for the outriggers.
- 10 t (11.0 tn. sh.) hook tackle, own weight 300 kg (661.4 lbs).
- 25 t (27.6 tn. sh.) hook block, 1 sheave, with single hook, own weight 375 kg (826.7 lbs).
- 63 t (69.5 tn. sh.) hook block, 3 sheave, with single hook, own weight 600 kg (1,322.8 lbs).
- 63 t (69.5 tn. sh.) hook block, 3 sheaves, with double hook, own weight 600 kg (1,322.8 lbs).
- 80 t (88.2 tn. sh.) hook block, 5 sheaves, with double hook, own weight 800 kg (1,763.7 lbs).
- 125 t (137.8 tn. sh.) hook block, 7 sheaves, with double hook, own weight 1,200 kg (2,645.6 lbs).
- Storage of hook block possible, with up to 3 sheaves (100 kg (220.5 lbs) extra weight, not in conjunction with the tool box).
- Front right tool box (50 kg (110.2 lbs) extra weight, not in conjunction with hook block storage).
- 2nd hoisting winch (as for main winch, without fast-approach mode).
- 2 working floodlights on the base boom (xenon), motor-driven adjustment from the superstructure cab.
- Aircraft warning lamp (can be removed from the boom pulley head and fitted to the jib).
- Loading and jump start socket.
- Additional oil cooler.
- Crane emergency operation, incl. hydraulic transformer for PAM in line with the requirements of the employers' liability insurance association.
- Country-specific equipment.



## 7 Service and Maintenance

### See also

📄 [Servicing-maintenance-OW-BlueTec \[→ 503\]](#)



# Contents

---

## Servicing and maintenance

<b>0</b>	<b>General instructions</b>	<b>1</b>
0.1	Before servicing and maintenance	1
0.2	Welding and alignment work	2
0.3	Checking the screw joints	2
0.4	Checking the hydraulic unit and its screw couplings for leak tightness	2
0.4.1	Durability of hydraulic hoses	2
0.5	Cleaning	3
0.6	After the servicing and maintenance	3
0.7	Parameterisation of electronic equipment	3
<b>1</b>	<b>Maintenance intervals</b>	<b>1</b>
1.1	Maintenance Schedule	3
<b>2</b>	<b>Engine</b>	<b>1</b>
2.1	Checking the oil level	2
2.2	Oil change / oil filter change	3
2.3	Checking the hose clamps of the charge-air hoses	3
2.4	Fuel tank	4
2.4.1	Draining off condensed water	4
2.4.2	Fuel filter	5
2.5	Coolant	6
2.5.1	Checking the coolant	6
2.5.2	Replacing the coolant	7
2.6	Cleaning the cooler	7
2.7	Air cleaner	8
2.7.1	Removing / installing an air cleaner cartridge	9
2.7.2	Check the air cleaner cartridge	10
2.6.3	Checking the air intake pipe and hoses	10
2.6.4	Check the electric ported vacuum switch on the clean air side of the air cleaner housing	10
2.8	Exhaust system	11
2.8.1	Maintaining the muffler-radio catcher*)	11
<b>3</b>	<b>Hydraulic system</b>	<b>1</b>
3.1	Checking the hydraulic oil level	1
3.2	Replacing the filter inserts	2
3.2.1	Replacing the ventilation filter insert	2
3.3	Oil change	3
3.4	Replace the pressure filter insert	3
3.5	Checking and tightening the screw couplings of the hydraulic units and pipes	3

3.5.1	Checking the screw couplings at the tubes	3
3.6	Oil cooler/additional oil cooler*)	3
<b>4</b>	<b>Swing mechanism</b>	<b>1</b>
4.1	Checking the oil level and leak tightness	2
4.2	Oil change	2
4.2.1	Checking the swing mechanism	3
4.2.2	Ventilation filter	3
4.3	Checking hydraulic oil in the working brake circuit of the swing mechanism	4
4.3.1	Bleeding the working brake circuit	4
4.3.2	Checking the slewing gear brake	5
4.4	Checking the slewing engine – gear drive shaft, tooth profile play	5
4.5	Lubricating swing mechanism gear rings and pinions	5
4.6	Lubricating the ball-bearing slewing ring	6
4.7	Greasing the swing mechanism – lock pins	7
4.8	Checking the functioning of the mechanical superstructure lock and proximity switch	7
4.9	Lubrication of the swing mechanism multi-disc chamber	7
4.10	Checking the gear ring-joint screws, fastening screws of the hydro motor, gear flange screws for firm fit	8
4.11	Checking the slewing ring for wear	8
<b>5</b>	<b>Hoisting gear / 2nd hoisting gear*)</b>	<b>1</b>
5.1	Checking the oil level and leak tightness	1
5.2	Oil change	2
5.3	Checking the oil level in the hoisting gear motor-engine coupling	2
5.4	Changing the oil in the hoisting gear motor/engine coupling	2
5.5	Checking the hoisting gear motor-gear drive shaft, tooth profile play	3
5.6	Preserving the hoisting gear drive	3
5.7	Check the hoisting gear brake	3
5.9	Checking the anti-twoblock device function	4
5.10	Check the over-unwind limit switch on the hoisting gear	4
5.10.1	Setting the over-unwind limit switch	5
<b>6</b>	<b>Hoisting rope</b>	<b>1</b>
6.1	Check	1
6.2	Cleaning and lubricating the hoisting rope	1
6.3	Laying the hoisting rope (rope change)	1
6.4	Checking the winch drum	2
6.5	Laying a new hoisting rope	2
6.6	Servicing the hoisting rope	2
<b>7</b>	<b>Electrical system</b>	<b>1</b>
7.1	Checking the batteries	1

# Contents

---

7.1.1	Specific weight and charge condition of the battery at +20 °C acid temperature	2
7.1.2	Installing new batteries	2
7.2	Three-phase generator	2
7.3	Starter	2
7.4	Lamps and lights	3
7.4.1	Place of installation, wattage and name of the lamps and lights in the superstructure	3
7.5	Automatic Safe Load Indicator (ASLI)	3
7.5.1	Checking the feed of hydraulic pumps	3
7.6	Regular inspection of the automatic safe load indicator (ASLI) as per the legal regulations	4
7.7	Fuse and relay chart	5
7.7.1	Fuses in the battery compartment	8
7.8	Counterweight control relay chart	9
<b>8</b>	<b>Crane cab</b>	<b>1</b>
8.1	Air conditioning system*)	1
8.1.1	Air condition - functional check	1
8.2	Wiper-blade elements / windscreen washing system	2
8.2.1	Replacing the wiper-blade elements	2
8.2.2	Windscreen washing system	2
8.3	Auxiliary heater	2
8.3.1	Replace the fuel filter	2
8.5	TADANO-Cockpit-Graphi7-Control System	3
8.5.1	Monitor	3
8.6	Clean the circulating air filter	3
<b>9</b>	<b>Other greasing, maintenance and servicing points</b>	<b>1</b>
9.1	Telescopic boom	1
9.1.1	Lubricating the telescopes/locks	1
9.2	Derrick cylinder	2
9.3	Bottom block	2
9.4	Counterweight	2
9.5	Jib*)	2
9.6	Central lubricating system	2
9.7	Other lubricating points	2
<b>10</b>	<b>Compressed air system</b>	<b>1</b>
10.1	Drain valves in the pressure tanks	1
10.2	Air dryer	2
10.2.1	Function check	2
10.2.2	Replacing the desiccating agent cartridge	2
10.3	Pressure governor with tire inflation socket (integrated in air drier)	3
10.3.1	Setting the shut-off pressure of the pressure governor	3

10.4	Test connectors for inspection of the compressed air system	4
10.5	Test and setting values	5
10.5.1	Compressed air system	5
15	<b>Overview of the oil grades and capacities</b>	1
16	<b>Grease Overview (Grease Recommendations)</b>	1
17	<b>Selection table for lubricants and anti-friction agents</b>	1

## 0 General instructions

Regular cleaning, careful servicing and maintenance ensure smooth operation and long service life of the machine.

All the necessary activities are described in the following Part "C" and must be carried out according to the intervals specified in the maintenance schedules for superstructures.

Servicing and maintenance work may be carried out by qualified, trained and authorised expert personnel only.

Special work on the engine and gearbox, which require specialized knowledge, has not been specified. For other details, refer to the operating manuals provided by the unit manufacturer.

A basic cleaning must be conducted at least once in three months where all the points with non-uniform coat of paint must be derusted and re-painted. All the bare parts must be protected against corrosion by lubrication in case of long periods of downtimes. Particularly, attention must be paid to corrosion protection for piston rods of operating cylinders.

If a mobile crane is being used in aggressive air (e. g. on the seaside in salty air), the free ends of the piston rods (e. g. on the tele cylinders) must be coated with oil at relatively short intervals.

### 0.1 Before servicing and maintenance

Optimum cleanliness and proper planning are prerequisites for all the activities that are to be carried out.

- Carry out maintenance work only when the engine is not running.
- Secure the machine against inadvertent rolling.
- Use only lint-free cleaning cloths, in particular when working on the hydraulic unit.
- Check the oil level only when the mobile crane is horizontal.

	The prescribed safety rules as per § 6 of the "Accident Prevention Regulations for Engines" must be adhered to when checking the oil level (Observe country-specific regulations deviating from this).
--	--

- Change oil only when the units attain the operating temperature.

	<b>CAUTION</b>
	<p><b>Risk of burns due to uncontrolled leaking of hot lubricating oil or hydraulic oil!</b></p> <p>There is a risk of burns due to uncontrolled leaking of hot lubricating oil or hydraulic oil.</p> <p>1) Do not let the lubricating or hydraulic oils drain off in an uncontrolled manner.</p>

	<b>CAUTION</b>
	<p><b>Risk of injuries!</b></p> <p>Systems such as: coolers, compressed air tanks, expansion tanks, etc. are under excess pressure. Hot liquids can gush out when opening and scald your skin and eyes.</p> <p>1) De-pressurise the systems before opening.</p>

- Determine and repair the cause in case of visible oil leakage. Regularly check, and if necessary retighten, any hose clamps for leak-tightness.
- Remove the batteries before starting work on the electrical systems, in which tools etc. can come in contact with the electrical parts. Remove the minus pole first and then the plus pole (when connecting, connect the plus pole first and then the minus pole).
- Clean the lubricators before greasing and then grease them as per the maintenance schedule.
- Grease all the hinges, all the movable, rotating parts without lubricators with the oil can as per the maintenance schedule.
- Repair any leakages in the line system immediately.
- When mounting covers, plugs, etc, pay attention to the proper condition and seating of the sealing elements, and replace them if necessary.
- All the elements or filter cartridges must be replaced after the specified intervals, if cleaning is not explicitly allowed.
- Should the oil or grease grade be changed for technical or operational reasons, then only the recommended qualities and viscosities must be used.
- Use only clean oils and lubrication greases stored in closed containers.
- Where the use of a fine-meshed strainer is recommended, pour or fill oils only with clean containers.
- Treat lubrication greases with clean resources only.
- Check the fastening and retaining elements, e.g. screws, nuts, spring washers, washers before reuse and if necessary, replace. Lock nuts must not be reused.
- Before dismantling, mark all the pipes and cables to be removed appropriately in order to eliminate a possibility of confusion when re-assembling after the repairs have been completed. Conduct a functional check. Check the compressed air, hydraulic and coolant pipes for leak tightness

## 0.2 Welding and alignment work

**Welding, heat treatments and alignment work on “load-bearing components” are basically prohibited (see Part E-1, section 1).**

By using high-strength steels, loss of material properties must be expected, if welding, heat treatments or alignment work is carried out improperly.

## 0.3 Checking the screw joints

Check all the joint and fastening screws including the individual units as well as all hose clamps regularly every three months for firm fit and retighten if necessary.

**Keep in mind the respective tightening torque when checking all the firm fits.**

The corresponding “FN 10009” standard for tightening torques can be obtained from the TADANO After-Sales Service.

## 0.4 Checking the hydraulic unit and its screw couplings for leak tightness

*Retighten leaky hydraulic screw couplings – if loose – in the depressurised state only.* The screw coupling must be replaced if the tightened screw couplings are leaky. Do not repair damaged tubes; replace them with new tubes instead.



### 0.4.1 Durability of hydraulic hoses

*Check hydraulic hoses and hose assemblies every week and replace them immediately if any damages such as chafe marks, cuts, cracks, deformations are determined or they work loose from the fitting and moisture penetrations become visible.*

The service life of the hose assemblies should not exceed 6 years from commissioning (see DIN 20 066, ZH 1/74) (observe country-specific regulations deviating from this).

## 0.5 Cleaning

The machine should only be washed with cold water for the first three months to avoid damage to the electrical equipment, the brake pipes and coat of lacquer. Avoid water temperatures above 70 °C and do not use any aggressive and inflammable cleaning agents.

Minimum distance of the nozzles from the vehicle must be 30 cm. Do not use any "power nozzles".

Never direct the cleaning jet directly towards rubber or electrical parts, hinges, length adjustment of the propeller shafts or breathers when cleaning with the high-pressure cleaning device (steam-jet air ejector).

Maximum pressure of the cleaning devices = 80 bar. Preferably, use fan nozzles.

## 0.6 After the servicing and maintenance

Re-attach the safety equipment properly after completing all the work. Check whether the machine is functioning properly.

	<b>WARNING</b>
	<b>Environmental pollution due to improper disposal!</b> Pay attention to the environmental regulations when disposing oil, grease, cleaning agents or oily components, e.g. filters. Dispose the waste oil as prescribed.

## 0.7 Parameterisation of electronic equipment

A new control parameterisation is necessary when replacing the engine, ASLI, crane control lever, sensor system etc. Only trained expert personnel may carry out this work.

For more information, please contact your TADANO After-Sales Service.

**Notes:**

# 1 Maintenance intervals

The maintenance intervals depend on the conditions of use of the vehicle, and the next maintenance becomes due after:

- a certain number of operating hours,
- a specified time.

<b>i</b>	The value that is reached first is decisive.
----------	--

The number of operating hours can be read out on the hourmeter. Maintenance work, which is due **before or other than** the periodic maintenance work, is marked in the maintenance schedule in the **“First Maintenance After”** column. Even one-time maintenance work carried out after the initial operation or component replacement is marked in this column. The **“Regular maintenance every 125 / 250 / 500 / 1000 / 2000 operating hours”** column is applicable after this maintenance work. Maintenance work, which has to be carried out everyday or before the commissioning of the vehicle, is marked with **“X”** in the maintenance schedule in **“Daily; before commissioning”**. The prescribed maintenance activities that have to be carried out time and again after the completion of a certain number of operating hours are marked with **“X”** in the **“Regular maintenance every 125 / 250 / 500 / 1000 / 2000 operating hours”** column.

E.g. “every 500 operating hours” i.e. when 500, 1000, 1500, etc. operating hours are completed,  
 “every 2000 operating hours” i.e. when 2000, 4000, 6000, etc. operating hours are completed.

<b>i</b>	The maintenance intervals are applicable to machines that are exposed to normal operating and environmental influences. The maintenance intervals have to be adapted to the conditions of use in particular cases.
----------	--

<b>i</b>	Even the maintenance activities that necessary at short intervals and coincide with this time must be carried out during every maintenance schedule.
----------	--

<b>i</b>	If tests have to be conducted for several similar parts (e.g. batteries, etc.) in the test and maintenance schedules, then only one part is included in the example.
----------	--

**Notes:**

1.1 Maintenance Schedule

Assemblies / Maintenance and Testing Work	See Part "C" point	First Maintenance After	Daily; before commissioning	Regular Maintenance Every					Minimum Intervals	Remarks
				125	250	500	1000	2000		
				Operating Hours (Oh)						
<b>Hydraulic pipes</b>										
Checking hydraulic hoses / hose assemblies for damage.	0.4								Weekly.	Replace hydraulic hoses at the latest after 6 years.
Replacing the hydraulic hoses	0.4								Every 6 years.	
<b>Engine</b>										
Checking leak tightness.	2		X							
Checking oil level.	2.1		X							
Oil change, oil filter change.	2.2						900 Oh		Yearly.	
Checking hose clamps of the charge-air hoses for firm fit.	2.3			X						
Draining off fuel tanks, condensed water.	2.4.1						X		Yearly.	Earlier if necessary.
Checking the fuel tank, ventilation filter	2.4.1.1						X		Yearly.	Earlier if necessary.
Draining off fuel filter, condensed water.	2.4.2.2			X						More often if necessary.
Replacing the fuel filter, element.	2.4.2.3						X		Yearly.	More often if necessary, depending on the fuel quality.
Checking hose clamps of the coolant hoses for firm fit and leak tightness.	2.5.1			X						
Checking the coolant.	2.5.1		X							
Replacing the coolant.	2.5.2							X	Every 2 years.	
Cleaning the cooler.	2.6				X					Earlier if necessary.
<b>Air cleaner</b>										
Cleaning the air cleaner	2.7						X			With every air cleaner

Assemblies / Maintenance and Testing Work	See Part "C" point	First Maintenance After	Daily; before commissioning	Regular Maintenance Every					Minimum Intervals	Remarks
				125	250	500	1000	2000		
				Operating Hours (Oh)						
housing.									maintenance. Depending on the dust accumulation, earlier if necessary.	
Checking the air cleaner housing for damage and cracks.	2.7								With every air cleaner maintenance.	
Changing the air cleaner cartridge.	2.7.1					X			And if the "Air cleaner" display lights up in the CGC.	
Checking the air intake pipe and hoses.	2.7.3			X						
Checking the electr. ported vacuum switch on the air cleaner housing.	2.7.4								If the "Air cleaner" display does not light up in the CGC in spite of a dirty air cleaner.	
Air cleaner monitoring	2.7.4		X						During the operation via the "air cleaner" display in the CGC.	
Checking the Air cleaner monitoring maintenance switch, functioning.	2.7.4.1					X				
<b>Exhaust system</b>										
Muffler – spark arrester *)	2.8.1			X					Empty and clean 2 to 3 time every year	
Cleaning the exhaust pipe	2.8.2					X		Yearly.		
<b>Hydraulic system</b>										
Checking the hydraulic system for leak tightness.	3/3.6		X							
Checking oil level.	3.1		X							
Replacing the filter inserts.	3.2	125 Oh				X		Yearly.	With every hydraulic oil change and when the display for filter soiling lights up in the CGC.	
Replacing the ventilation filter.	3.2.1						X		When it gets dirty or earlier if necessary.	

Assemblies / Maintenance and Testing Work	See Part "C" point	First Maintenance After	Daily; before commissioning	Regular Maintenance Every					Minimum Intervals	Remarks
				125	250	500	1000	2000		
				Operating Hours (Oh)						
Cleaning the filling strainer.	3.2.1.1								Every 2 years.	If necessary.
Oil change.	3.3							X	Every 2 years.	Check the oil regularly.
Replacing the pressure filter insert.	3.5							X		
Cleaning the oil cooler /additional oil cooler radiator fins.	3.7			X						
Checking the oil cooler/additional oil cooler vent and functioning of the thermo switch.	3.7			X						
<b>Swing mechanism</b>										
Visual gearbox check.	4								Every 3 years.	Internally and externally.
Checking leak tightness.	4.1		X							
Checking the gear oil level.	4.1		X							When the gearbox is at a standstill.
Changing the gear oil.	4.2	200 Oh and then at 1,000 Oh						X	Yearly.	Conduct an oil check with every oil change.
Checking the hydraulic oil level in the supply tank of the slewing brake.	4.3			X						
Checking the slewing brake for functioning and leak tightness.	4.3.2		X						Yearly.	
Checking the slewing engine – gear drive shaft, tooth profile play.	4.4								Yearly.	

Assemblies / Maintenance and Testing Work	See Part "C" point	First Maintenance After	Daily; before commissioning	Regular Maintenance Every					Minimum Intervals	Remarks
				125	250	500	1000	2000		
				Operating Hours (Oh)						
Lubricating slewing rings and pinions.	4.5			X						Depending on the slewing frequency, earlier if necessary.
Greasing the turntable bearing (provided using central lubricating system).	4.6			X						Depending on the slewing frequency, earlier if necessary.
Greasing the lock pins.	4.7			X						
Checking the function for mechanical latching of superstructure and proximity switch.	4.8		X							
Checking firm fit of the gear ring connecting screws, fastening screws of the hydro motor and gear flange screws.	4.10	100 to 125 Oh				X				Pay attention to the tightening torque.
Checking the tipping backlash of the slewing ring.	4.11									As required.
<b>Hoisting gear / 2nd hoisting gear*)</b>										
Visual gearbox check.	5								Every 3 years.	Internally and externally.
Checking leak tightness.	5.1		X							
Checking oil level.	5.1/5.3		X							
Oil change.	5.2/5.4	200 Oh and then at 1,000 Oh						X	Yearly.	Conduct an oil check with every oil change.
Checking the tooth profile play.	5.5						X		Yearly.	
Checking the hoisting gear brake discs and free-wheel clutch.	5.8						X		Yearly.	



Assemblies / Maintenance and Testing Work	See Part "C" point	First Maintenance After	Daily; before commissioning	Regular Maintenance Every					Minimum Intervals	Remarks
				125	250	500	1000	2000		
				Operating Hours (Oh)						
Checking the anti-twoblock device function.	5.9		X						During the operation.	
Checking the functioning of the over-unwind limit switch.	5.10					X			And during every cable change.	
<b>Hoisting rope</b>										
Check	6.1		X					Weekly.	Before and after every operation.	
Cleaning.	6.2								In case of lot of soiling.	
Rope lubrication and servicing.	6.2				X				Earlier if necessary and after every cleaning.	
Checking the rope drum for wear.	6.4					X			And before laying a new hoisting rope.	
<b>Electrical system</b>										
Checking the batteries.	7.1			X				Monthly.		
Lubricating the battery poles.	7.1								As required.	
Checking the three-phase generator.	7.2						X		Pay attention to the correct V-belt tension.	
Checking the starter.	7.3						X		Keep in mind the instructions of the engine manufacturer.	
Checking the functioning of the lamps and pilot lamps.	7.4		X							
Cleaning the lamp glasses and checking for any damage.	7.4		X						When it gets dirty or earlier if necessary.	
Checking the functioning of the Automatic Safe Load Indicator (ASLI).	7.5		X							
Automatic Safe Load Indicator (ASLI). Checking the feed of hydraulic pumps.	7.5.1						X		Check only after carrying out all other prescribed maintenance activities.	
Inspecting the ASLI.	7.6					X				

Assemblies / Maintenance and Testing Work	See Part "C" point	First Maintenance After	Daily; before commissioning	Regular Maintenance Every					Minimum Intervals	Remarks
				125	250	500	1000	2000		
				Operating Hours (Oh)						
<b>Crane cab</b>										
Greasing and lubricating hinges, pins, hinge-joints and all movable parts.	8			X				Every two weeks.	As well as after every car wash with the high pressure – steam jet blower.	
Treating door locks (lock cylinder).	8					X		Yearly.		
Air condition*). Inspect.	8.1					X		Yearly.	In a specialist workshop.	
Cleaning the wiper-blade elements.	8.2.1				X			Monthly.	More often if necessary.	
Replacing the wiper-blade elements.	8.2.1					X		Yearly.	Or in case of damage.	
Checking the fluid level and adding the fluid in the container of the windscreen washing system.	8.2.2				X			Monthly.	More often if necessary.	
Replacing the fuel filter of the auxiliary heater.	8.3.1					X		Yearly.	Before starting the heating operation.	
Checking/cleaning the circulating air cleaner	8.6								If necessary, i.e. in case of reduced air output in the circulating air operation	
<b>Other greasing, servicing and maintenance points</b>										
<b>Telescopic boom</b>										
Lubricating sliding pieces, slide coverings, sliding rails, horn cheeks and guide rollers.	9.1			X						
Lubricating the telescopes/locks.	9.1.1			X						
<b>Bottom block</b>										

Assemblies / Maintenance and Testing Work	See Part "C" point	First Maintenance After	Daily; before commissioning	Regular Maintenance Every					Minimum Intervals	Remarks
				125	250	500	1000	2000		
				Operating Hours (Oh)						
Greasing the hook block cross member.	9.3				X					
<b>Counterweight</b>										
Checking the leak tightness of the locking cylinder.	9.4		X							
<b>Jib*)</b>										
Lubricating and greasing sheave holder, bearings and boltings.	9.5				X					
<b>Central lubricating system</b>										
Checking the capacity of the container and replenishing if necessary	9.6								If necessary.	
Checking the pipes and screw couplings for damage.	9.6			X						
<b>Other lubricating points</b>										
Greasing hinges, pins, hinge-joints and all movable parts.	9.7			X				Every two weeks.	As well as after every car wash with the high pressure – steam jet blower.	
<b>Compressed air system</b>										
Check compressed air system for leakage.	10.1		X							
Actuate drainage valves of air tanks.	10.1			X				Every 2 weeks		
Cleaning drainage valves of air tanks.	10.1						X	Once per year		
Functional check of air drier.	10.2.1			X						
Replacement of air drier cartridge.	10.2.1 10.2.2							Every 2 years	If necessary, earlier.	
Pressure governor - check for proper working order and visual inspection of its internal components.	10.3						X		Inspection according to the legal regulations of the country where the machine is to be registered.	

Assemblies / Maintenance and Testing Work	See Part "C" point	First Maintenance After	Daily; before commissioning	Regular Maintenance Every					Minimum Intervals	Remarks
				125	250	500	1000	2000		
				Operating Hours (Oh)						
Inspection of the compressed air system.	10.4						X		Inspection according to the legal regulations of the country where the machine is to be registered.	

**Notes:**







---

**Notes:**

**Notes:**



## 2 Engine

	<p><b>! DANGER</b></p> <p><b>Risk of fire and explosion due to fuel!</b>          Not observing the following points can lead to burns or potentially fatal injuries.</p> <ol style="list-style-type: none"> <li>1) It is prohibited to smoke and use open flames when working with fuel or during maintenance on the batteries.</li> </ol>
	<p><b>! WARNING</b></p> <p><b>Risk of accident due to rotating parts!</b>          Maintenance work when the engine is running can lead to potentially fatal injuries.</p> <ol style="list-style-type: none"> <li>1) Carry out maintenance work only when the engine is stopped.</li> </ol>
	<p><b>! WARNING</b></p> <p><b>Maintenance work without adequate safety precautions!</b>          There is an increased risk of falling when carrying out maintenance work from an elevated place without adequate safety precautions. This may cause injuries, which could even be lethal sometimes.</p> <ol style="list-style-type: none"> <li>1) The personnel must be protected with suitable aids (e.g. platform, railing) when carrying out maintenance work on the mobile crane.</li> <li>2) Use the existing access steps and ladders.</li> </ol>
	<p><b>! CAUTION</b></p> <p><b>Risk of injuries!</b>          Systems such as: coolers, compressed air tanks, expansion tanks, etc. are under pressure. Hot liquids can gush out when opening and scald your skin and eyes.</p> <ol style="list-style-type: none"> <li>1) De-pressurise the systems before opening.</li> </ol>

For the general required testing, maintenance and inspection work on the engine such as:

- Checking the engine oil level,
- Engine oil change,
- Replacing lubricating oil filter,
- Replacing fuel filter inserts,
- Cleaning fuel pre-filter-filter inserts,
- Checking V-belt condition,
- Checking the valve play
- Fault finding etc.,

refer to the operating manual provided by the engine manufacturer.

- Check the engine regularly for leak tightness.

### Releasing the lateral lid of maintenance port.

The lateral lid of the maintenance port is opened by removing the locks (1).

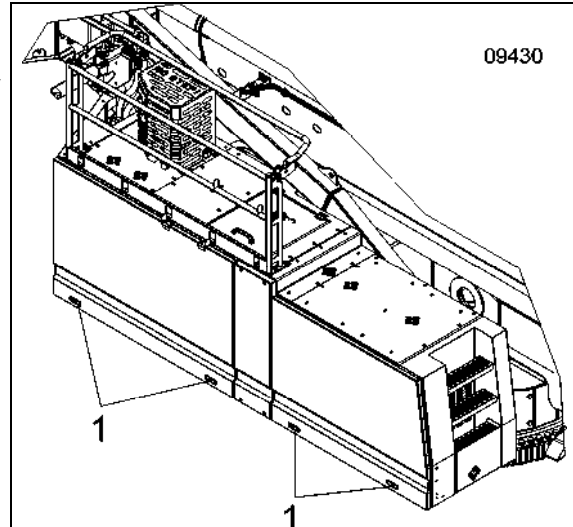

## 2.1 Checking the oil level



The oil level is checked and the oil is replenished via the maintenance opening (2) in the engine cover.

Open the lid of the maintenance port (2) using the handle (1).

The oil is replenished via the oil filler (3).

Oil level is measured using the oil dipstick (4).

For oil level check and oil filling, refer to specifications by the engine manufacturer.

The oil level of the engine can be monitored by means of a symbol in the TADANO Control and Service System when the engine is not running.

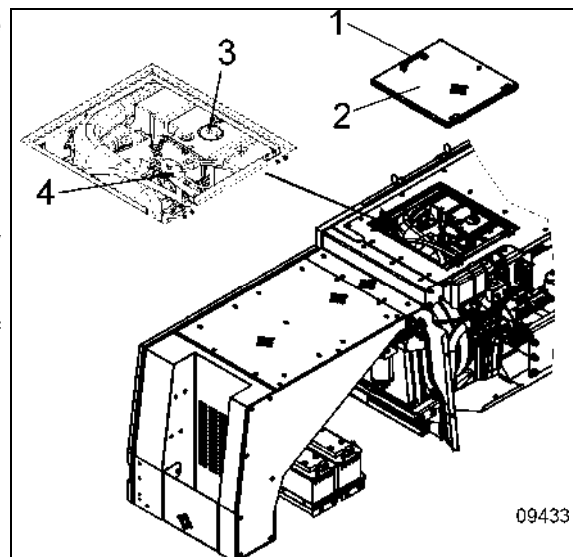

## 2.2 Oil change / oil filter change

	<b>NOTE</b>
	<p><b>Damage to the engine due to old or incorrect engine oil!</b>                  Change the oil and the oil filter every 900 operating hours, but at least once a year.</p> <ol style="list-style-type: none"> <li>1) However, these intervals are applicable only when oils with DB approval 228.5 are used.</li> <li>2) The operating regulations of the engine manufacturer must be followed.</li> </ol>

	<p>In order to simplify the process of collecting the waste oil when changing the engine oil, the serially built-in oil drain screw can be replaced with a provided drain valve during the first oil change.</p>
---	--

For a subsequent oil change, the capscrew (1) of the drain valve (2) must be unscrewed and the oil drain hose (3) in the tool box must be loosened instead. The drain valve opens due to the unscrewing process and the oil can drain off through the hose into the collecting container that is provided.

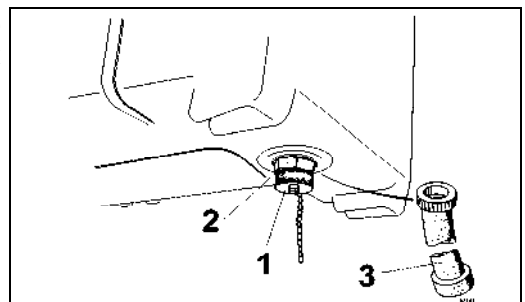

After completing the work, the drain hose must be removed again, the thread must be cleaned with an absorbent cleaning cloth and the capscrew must be screwed on again.

	<b>NOTE</b>
	<p><b>Environmental pollution due to waste oil and the oil filter!</b>                  The waste oil and the oil filter are harmful to the environment.</p> <ol style="list-style-type: none"> <li>1) Dispose the waste oil and filter in an eco-friendly manner.</li> </ol>

## 2.3 Checking the hose clamps of the charge-air hoses

	<p>The hose clamps of the charge-air hoses have cup springs on a threaded housing. The maximum tightening torque of 10.2 Nm must not be exceeded when retightening the clamps.</p>
---	--

- Check the hose clamps of the engine charge-air hoses for firm fit as per the maintenance schedule.

## 2.4 Fuel tank

### 2.4.1 Draining off condensed water

Condensed water can accumulate in the fuel tank in cases of extreme weather conditions.

Empty the tank up to the reserve, unscrew the drain plug (1) from the tank bottom and let the condensed water drain off into a suitable container. Keep the drain open until the clean fuel starts draining.

Clean the sealing surfaces with an absorbent cleaning cloth before screwing in.

- Check, clean, and if necessary replace, the sealing element (2).
- Screw in the drain plug (1) with the sealing element (2) and tighten.

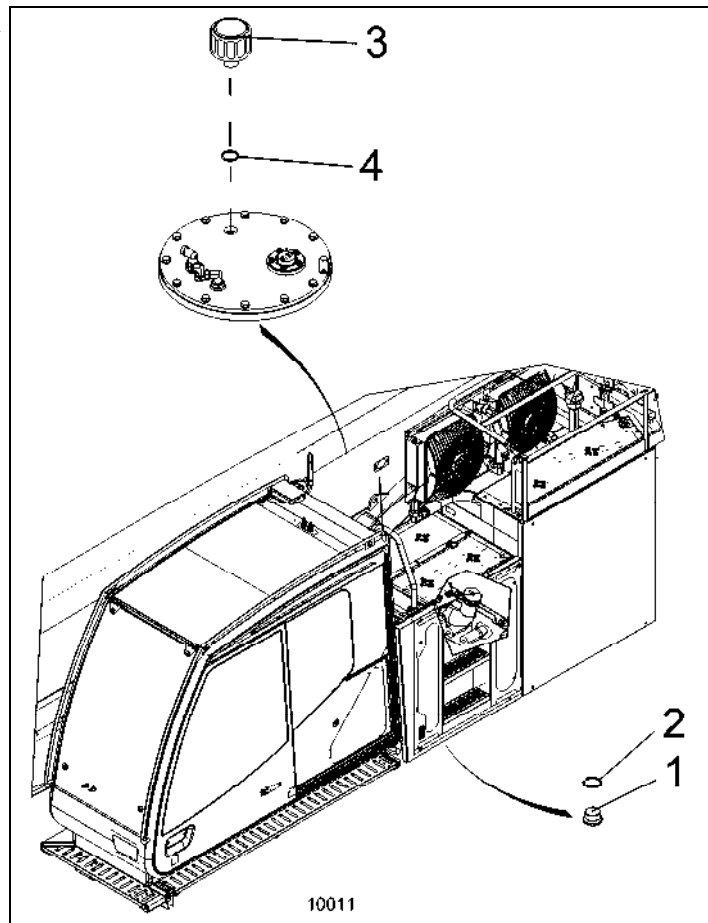

### 2.4.2.2 Ventilation filter

- Check the ventilation filter (3) for damage/soiling, clean and replace if necessary.
- Check, clean, and if necessary replace, the sealing element (4) when changing the ventilation filter.

2.4.2 Fuel filter

<b>i</b>	The fuel filter is located under the air cleaner covering.
----------	--

- Open the lid of the maintenance port (1) after removing the lock (2).

The fuel filter (3) is accessible for carrying out the maintenance work.

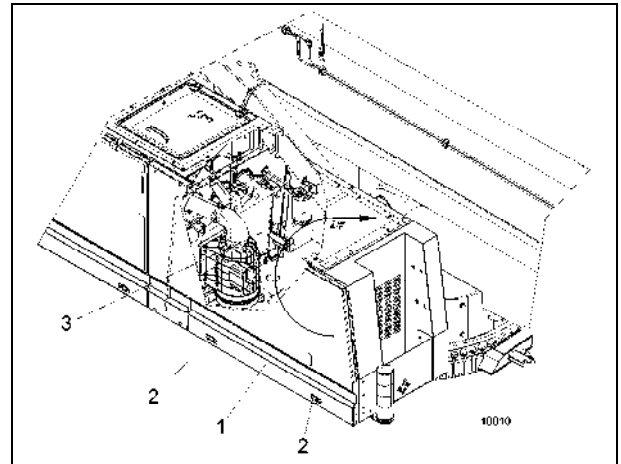

2.4.2.3 Draining off condensed water

- Open the drain valve (1) and let the accumulated condensed water drain off into a suitable container.

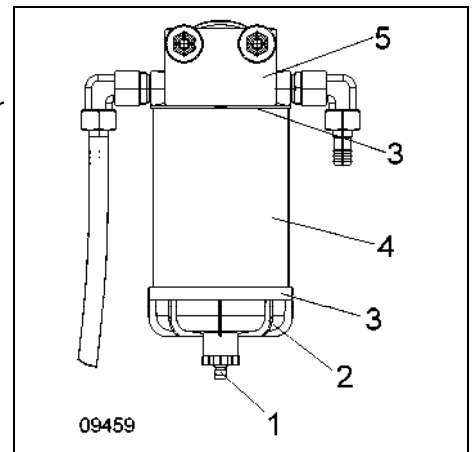

	<b>NOTE</b>
<p><b>Frozen condensed water!</b> Drain off the condensed water before the start of the frost period. Repeat the process more often if necessary.</p>	

2.4.2.4 Changing the fuel filter

- Let the entire filter content drain off as described in section 2.4.2.2.
- Loosen the filter (4) and the filter base (2) from the upper section of the filter (5).
- Separate the filter base from the filter and clean the filter base (e.g. using diesel).
- Clean the sealing surfaces.
- Lubricate new sealing elements with diesel and insert them into the sealing flange (3).
- Screw the filter base (2) with a new filter element such that it is hand-tight and then screw on the filter element (4) on the upper section of the filter (5).
- Tighten all parts firmly.
- Bleed the system.

## 2.5 Coolant

	<p><b>NOTE</b></p> <p><b>Engine damage from mixing different coolants.</b> Mixing different coolants can cause flocculation and thus engine damage.</p> <ol style="list-style-type: none"> <li>a) Use only coolants that conform to the Mercedes Benz specification 325.5 (Glysantin G40).</li> <li>b) Do not mix coolants that conform to the Mercedes Benz specification 325.5 with other coolants.</li> <li>c) If no coolants that conform to the Mercedes Benz specification 325.5 (Glysantin G40) have yet been put into the cooling system, the cooling system must be flushed before the new coolant is put in.</li> </ol>
<p><b>i</b></p>	<p>The expansion tank is located below the lid of maintenance port (2).</p>

- Open the lid of the maintenance port (2) using the handle (1).  
The expansion tank (3) is accessible for carrying out the maintenance work.

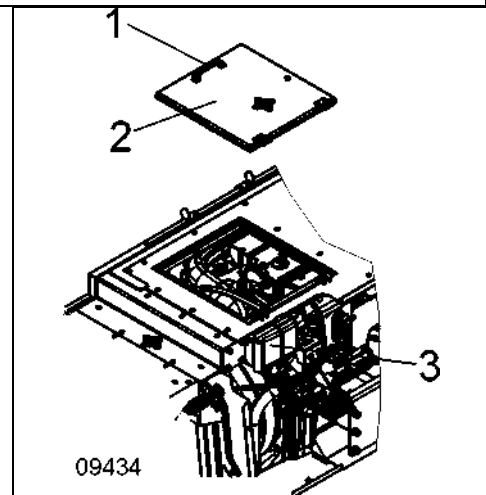

### 2.4.3 Checking the coolant

	<p><b>WARNING</b></p> <p><b>Risk of injuries!</b> The cooling system is under pressure. Hot coolant can gush out when opening and scald your skin and eyes.</p> <p>▷ The coolant tank may be opened only when the coolant temperature drops below 90 °C.</p> <ol style="list-style-type: none"> <li>1) Loosen the cap slowly using safety gloves or a cloth and release the excess pressure completely before opening.</li> </ol>
---	---

The cooling system is filled correctly if the coolant level is between the "Maximum (1) and Minimum marking" (2) of the expansion tank (3).

Check the anti-freeze property using a tester. The frost protection must be -37 °C all year round.  
 Replenish or replace the anti-freezing agent released by the engine manufacturer if necessary.  
 The entire cooling system must be drained if the coolant is replaced or the cooling system is re-filled after repairs.

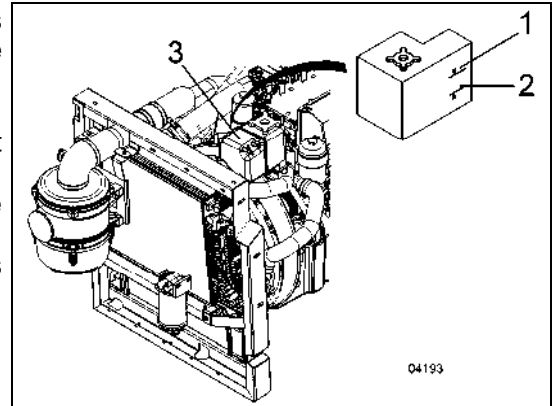

<b>i</b>	In case of any leaky cooling water hose connection, the hose clamps should not only be retightened or replaced, but even the functioning of the pressure-control valve in the valve cover should be checked. A defective valve can lead to overpressure in the cooling circuit and thus to a leakage.
----------	---

### 2.4.4 Replacing the coolant

<b>i</b>	The hot water heater of the vehicle must be opened before changing the coolant.
----------	---

The drain plug is located at the lower side of the cooler. It is provided at the lowermost point of the cooling system.

- Open the drain plug (1) and the cover of the expansion tank and let the coolant drain off into a suitable container.
- Screw in the drain plug and fill the coolant mixture through the expansion tank.
- Start the engine and let it run at varying speeds for approximately 1 minute.
- Stop the engine, check the coolant level in the expansion tank and refill it if required.

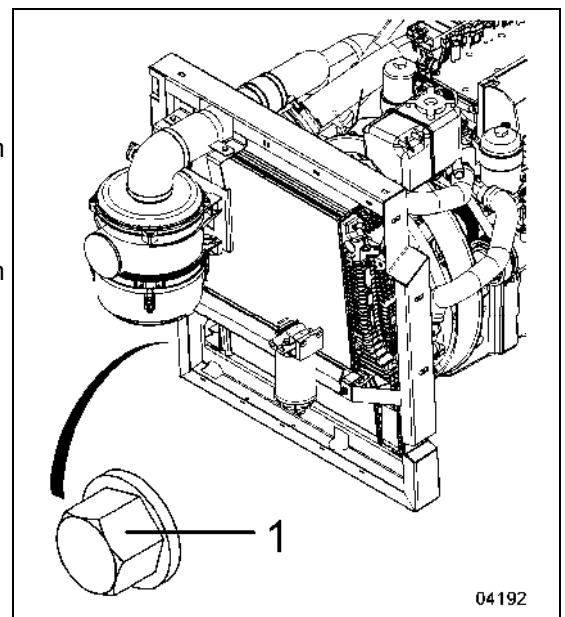



<b>i</b>	Dispose the coolant in an eco-friendly manner.
----------	--

For draining the entire coolant from the engine, refer to the operating manual provided by the engine manufacturer.

## 2.6 Cleaning the cooler

The radiator fins of the charge air and water cooler must be cleaned by blowing out with compressed air or with the brush depending on the dust accumulation.

## 2.7 Air cleaner

	<p><b>NOTE</b></p> <p>Carry out the maintenance work on the air cleaner only when the engine is stationary.</p> <p>Switch off the main switch of the battery.</p> <p>Do not start the engine when the air cleaner element has been dismantled!</p>
	<p>The air cleaner cartridge must be serviced outside the normal change intervals only when the “Air cleaner” symbol lights up in the TADANO Control and Service System when the engine is running. However, the air cleaner housing must be cleaned in-between depending on the conditions of use and the resulting dust accumulation.</p>
	<p>Check the air cleaner housing for damage and cracks during every air cleaner maintenance</p>

The air cleaner (3) is located under the air cleaner covering.

- Open the lid of the maintenance port (1) after removing the lock.

The air cleaner (3) is accessible for carrying out the maintenance work.

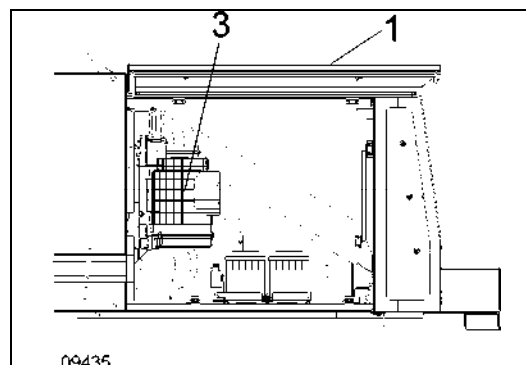



2.4.5 Removing / installing an air cleaner cartridge

- Open the bracket (1).
- Remove the cap (3) of the air cleaner housing.
- Carefully remove the air cleaner cartridge (2) completely from the air cleaner housing by slight rotary motions.
- Check the air cleaner housing for damage and cracks and replace it if required; clean the sealing surfaces of the air cleaner housing and the cap carefully using a moist cloth.

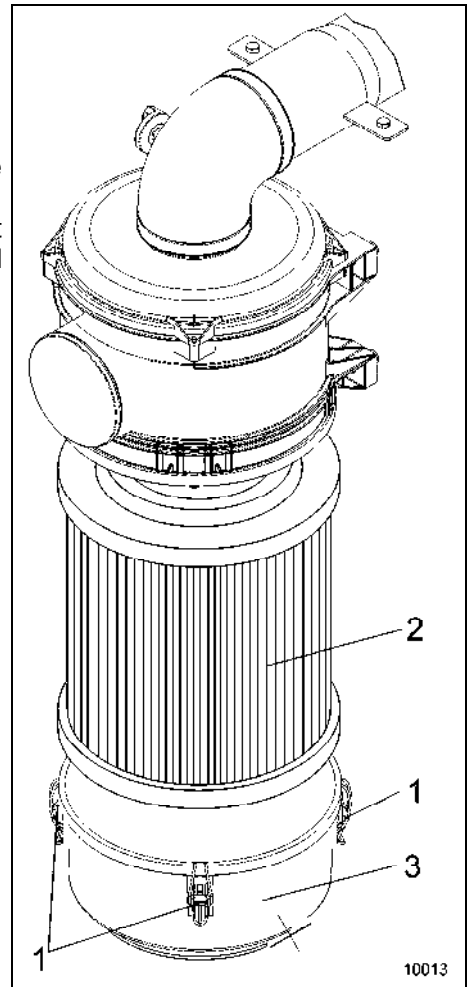

**NOTE**

**Damage to the engine due to dust in the air intake system!**

No dust should get into the air intake system of the engine when cleaning the air cleaner housing.

Do not blow it out with compressed air.

1) Remove the dust with a lint-free cloth.

## 2.4.6 Check the air cleaner cartridge

Check the **new** air cleaner cartridge before installing.

<b>i</b>	Under no circumstances should an air cleaner cartridge with visible damage - buckling, damaged filter surface, etc. be used. Replace defective air cleaner cartridges immediately.
----------	---

### 2.4.2.5 Maintenance notes

The air cleaner must be serviced correctly and reliably. Improper maintenance can cause damage to the engine.

Do **NOT** depend on the visual report of the air cleaner cartridge for carrying out the servicing. An air cleaner cartridge must look dirty once it has completed its task.

Never clean an air cleaner cartridge by

- dusting,
- washing out,
- blowing out,
- other cleaning measures

## 2.4.7 Checking the air intake pipe and hoses

- Check all the hose connections between the air cleaner and engine as well as charge-air hoses for firm fit.
- Check hoses and tubes for porosity and cracks.

## 2.4.8 Check the electric ported vacuum switch on the clean air side of the air cleaner housing

If the "Air cleaner" pilot lamp does not light up in spite of a dirty air cleaner, check the functioning of the electric ported vacuum switch. It is also possible that the indicator lamp is defective.

### 2.4.2.6 Checking the air cleaner monitoring function

- **Slowly** reduce the outer case of the air cleaner system when the engine is running by covering (e.g. with a board or plate) until the Air cleaner symbol lights up.

	<b>NOTE</b>
	<p><b>Risk of damage to the suction path!</b> When checking the air cleaner monitoring function, the suction path may get damaged if the intake opening is reduced too quickly.</p> <p>1) The intake opening may <u>not</u> be reduced any further after the Air cleaner symbol lights up.</p>

## 2.8 Exhaust system

The exhaust system is made of stainless steel. It does not require special servicing and maintenance.

### 2.4.9 Maintaining the spark arrester\*)

#### Cleaning the soot container

Unscrew the lock (2) to remove accumulated soot particles from the soot container (1).

Emptying the soot container regularly is very important for the efficiency of the radio catcher.

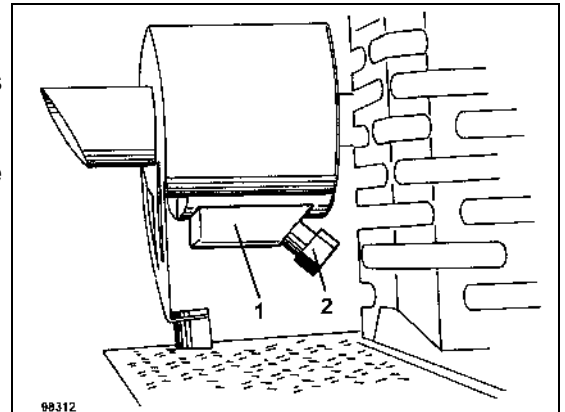

### 2.4.10 Cleaning the exhaust pipe

	<b>CAUTION</b>
<b>Risk of burns due to contact with hot parts of the exhaust system!</b>	
Touching hot exhaust components may cause burns.	
1) Remove components of the exhaust system only after they have cooled down.	

	Pay attention to the graphite seal! Before mounting the seal, clean, check and - if necessary - replace it.
--	---

1. Remove the covering (1).
2. Open the servicing lid (2).
3. Release and remove retaining elements (3).
4. Remove the exhaust pipe (4).
5. Remove existing deposits using appropriate means.
6. Re-install exhaust pipe.
7. Close the servicing lid.
8. Mount the covering (1).

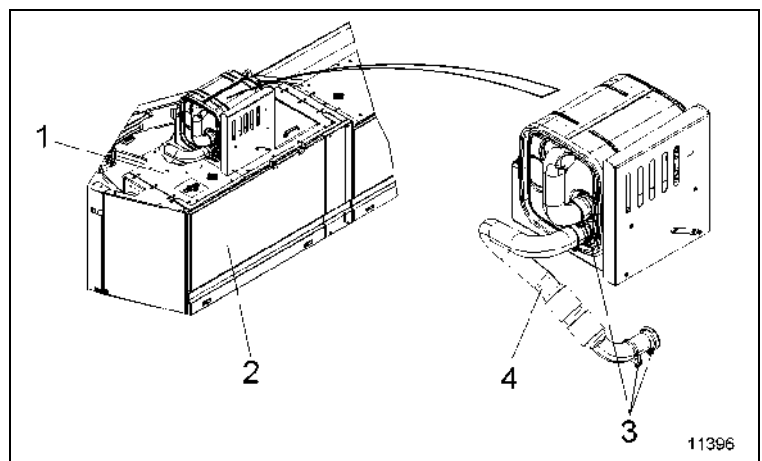

**Notes:**

### 3 Hydraulic system

	<b>! DANGER</b>
	<b>High oil pressures in pipes!</b> Risk of accident when servicing the hydraulic system when the engine is running. 1) Carry out work on the hydraulic system only when the engine is turned off.

- Check the hydraulic system regularly for leak tightness.

- For checking and tightening the screw couplings of the hydraulic units and pipes, see section 3.6.

	<b>! WARNING</b>
	<b>Risk of accident due to the damaged hydraulic pump!</b> The hydraulic pump can be damaged if the fuel valves are closed. 1) Close the fuel valves only when carrying out repair work on the hydraulic system. 2) Open the fuel valves before commissioning the mobile crane.

### 3.1 Checking the hydraulic oil level



#### **WARNING**

##### **Risk of accidents due to the low oil level!**

The hydraulic pump can be damaged if the oil level is very low. The cylinders cannot be extended completely.

- 1) Check the oil level and replenish if necessary.

- The hydraulic oil level can be read on the sight glass (2).

Hydraulic oil is filled up to mid-level of the sight glass (2) with:

- Mobile crane in the transport position, horizontal,
- Telescope cylinder in telescope section 1 locked at 0%,
- Superstructure engine turned off,
- 20 °C hydraulic oil temperature.

- The oil is filled through the opening of the ventilation filter (1).

- Unscrew the ventilation filter (1) and replenish oil through the opening.
- Screw on the ventilation filter (1) again.

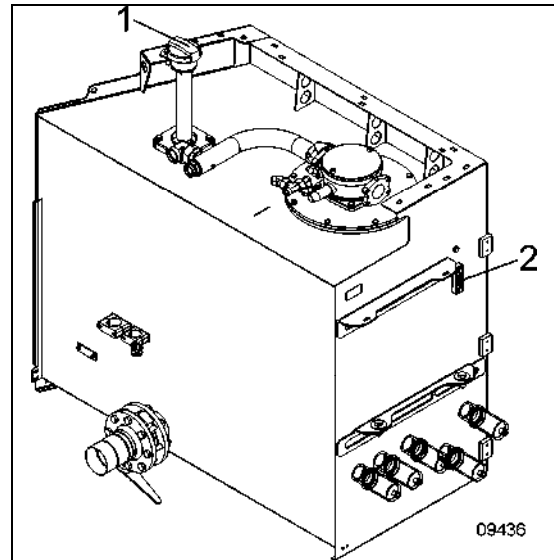



A temperature difference of 10°C causes the oil level to vary by approx. 6 mm.



Only replenish the new hydraulic oil from clean containers.

### 3.2 Replacing the filter inserts

	<p style="text-align: center;"><b>! DANGER</b></p> <p><b>High oil pressures in filters!</b> Risk of accident when servicing the hydraulic system when the engine is running. a) Carry out work on the hydraulic system only when the engine is turned off.</p>
	<p>The filter insert must be replaced every time the hydraulic oil is changed, if the “Hydraulic Oil Filter Contamination” symbol or “Central Warning” warning lamp lights up as well as according to the maintenance schedule.</p>

- Remove the fastening screws and take off the filter cover (4).
- Remove the filter insert; drain the waste oil.
- Clean, check and, if necessary, replace the cover seal.
- Clean the seal of the filter cover (4) and the sealing surfaces with a lint-free cloth.
- Insert a new element.
- See to it that the sealing element has been placed correctly.
- Put on the filter cover (4) again and retighten the fastening screws.

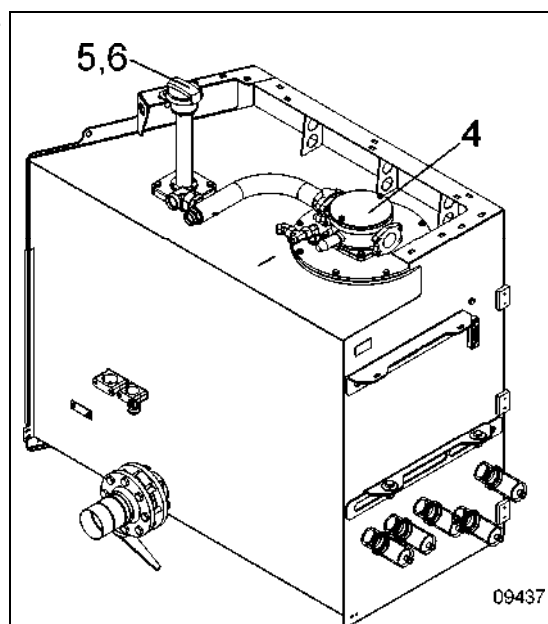

#### 3.2.1 Replacing the ventilation filter insert

- If the ventilation filter (5) is dirty or clogged up, open it and replace the filter element with a new filter element.

##### 3.2.1.1 *Cleaning the filling strainer*

- If the filling strainer is dirty or clogged up, open the ventilation filter (5) and clean the filling strainer (6).

### 3.3 Oil change



#### NOTE

##### Damaged pump due to the lack of hydraulic oil

Lack of hydraulic oil may damage the hydraulic pumps.

- 1) Change the oil only when the engine is at a standstill.

- Telescope and derrick cylinders are retracted.
  - The superstructure is turned by approximately 90 degrees.
- Close the fuel valve (7) in the suction pipe.
  - Remove the drain plug (8) and let the oil drain off into a suitable container completely.
  - After completing work, clean the sealing surfaces and the sealing element, check and, if required, replace them; close the oil tank using a drain plug (8).
  - Replace the filter insert as described in section 3.2.
  - Remove any impurities after removing the cover (9).
  - Purge the tank with diesel, petroleum or similar.
  - Ensure that there are no impurities in the tank. Remove the flushing fluid completely.
  - Clean the sealing surfaces, clean, check, and if necessary, replace the sealing elements.
  - Mount the cover (9) again. Tighten the fastening screws.
  - Fill new oil as described in point 3.1.
  - Remove impurities, if any.
  - Open the fuel valve (7) in the suction pipe again.

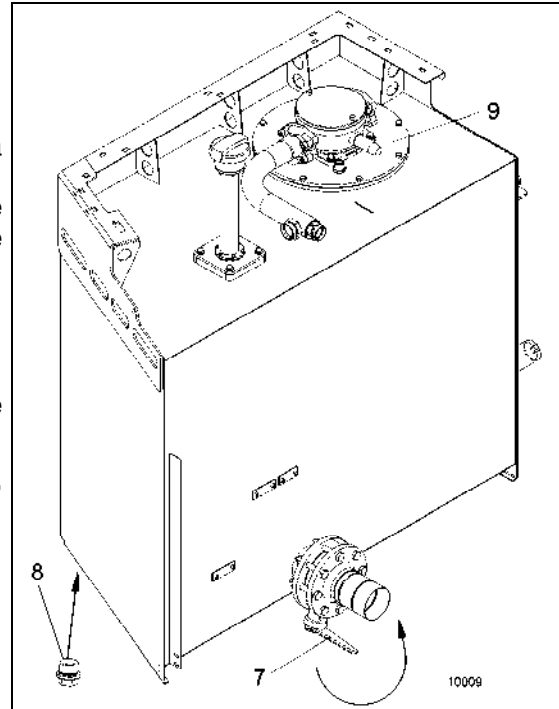

Before the scheduled oil changes or at regular intervals, we recommend consulting the oil supplier and analyse whether the oil needs to be changed. Vehicles with a minimum degree of purity compliant with the ISO 4406 class 18/16/13 are delivered. Up a degree of purity of 20/18/15, the operation of hydraulic components is ensured.



#### NOTE

##### Environmental pollution due to waste oil and the oil filter!

The waste oil and the oil filter are harmful to the environment.

- 1) Dispose the waste oil and filter in an eco-friendly manner.



### 3.4 Switching to another oil

	<p><b>NOTE</b></p> <p><b>Malfunctions in the hydraulic system!</b></p> <p>When the hydraulic system is switched from hydraulic oils on a mineral oil basis to biodegradable hydraulic oils, the VDMA 24569 Directives must be followed.</p> <p>Contact our TADANO After-Sales Service regarding an approved additive when switching to biodegradable hydraulic oils for the first time.</p>
---	---

The hydraulic system can be switched to biodegradable hydraulic oils according to VDMA 24568.

### 3.5 Replace the pressure filter insert

- Unscrew the filter housing (1) and replace the filter insert.
- Clean the sealing surface with a lint-free cloth before installing.
- Dispose the filter in an eco-friendly manner.

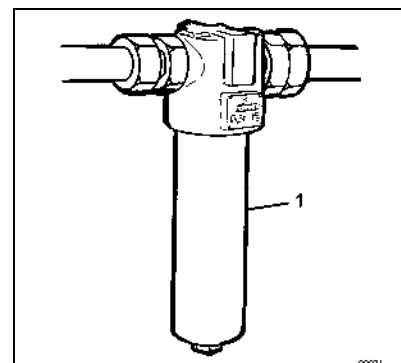

### 3.6 Checking and tightening the screw couplings of the hydraulic units and pipes

- Check the leak tightness of the tubes as per the maintenance schedule.
- In case of any leakage at the adjustable screw couplings and units, see to it that the cap nuts on the tubes or hose pipes are first removed, then the adjustable screw couplings are tightened firmly in the units and subsequently, the cap nuts of the tubes or hose pipes are re-fastened.
- Perfect leak tightness is ensured only when the above-mentioned sequence is followed and complied with.
- In case of leakage at the cap nuts of the tubes, check that the cap nuts are fixed properly and replace the screw coupling if necessary.

#### 3.6.1 Checking the screw couplings at the tubes

Remove the cap nuts and check whether the gap between the packing ring and retaining ring is bridged.

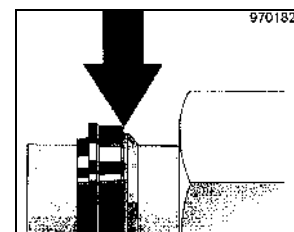

Replace the screw coupling if necessary.



**3.7 Oil cooler/additional oil cooler\*)**

- Clean radiator fins with compressed air depending on the dust accumulation.
- Check the vent and the thermo switch for functioning.



## 4 Swing mechanism

	 <b>DANGER</b>
	<p><b>Risk of accident due to unintentional commissioning!</b>                  People may get injured or die due inadvertent commissioning of the mobile crane. Keep in mind the following points when carrying out the servicing and maintenance work:</p> <ol style="list-style-type: none"> <li>1) Work on the swing mechanism only in case of standstill and load-free state.</li> <li>2) Take protective measures against unintentional commissioning before starting the work.</li> <li>3) Ensure that no persons are present in the danger zone before commissioning after the maintenance or repair work.</li> </ol>

	<p>The swing mechanism must be inspected visually from inside and outside every three years for improving the safety.</p>
---	---

### 4.1 Checking the oil level and leak tightness

- Check the swing mechanism regularly for leak tightness as per the maintenance schedule.
- Defective gaskets can reduce the service life of the swing mechanism.
- Oil leakage or very low oil level in the gearbox can lead to damage.

	 <b>CAUTION</b>
	<p><b>Hot oil in the swing mechanism!</b>                  Risk of scalding due to hot oil.</p> <ol style="list-style-type: none"> <li>1) Let the oil cool down.</li> </ol>

	<b>NOTE</b>
	<p><b>Malfunctions due to mixing of oils!</b>                  Mixing the different oil types may lead to malfunctions in the hydraulic system.</p> <ol style="list-style-type: none"> <li>1) Do not mix oils of different manufacturers, types and grades.</li> </ol>

- Check the oil level regularly as per the maintenance schedule when the gearbox is at a standstill and the oil has cooled off.
- The gearbox must be filled with oil up to the checking tap or the sight glass (5) after unscrewing the level control screw (4) (M 10x1); if necessary, replenish with the suitable oil via the expansion tank (1) by means of a funnel or hose. Remove ventilation filters (2) for this purpose.
- Check the oil level again and top up if necessary.

#### 4.2 Oil change

- Change the oil regularly as per the maintenance schedule at the operating state temperature.
- Allow the oil to drain off via the drain hole into a suitable container by unscrewing the oil drain screw R 1/4" (6).
- Clean, check and, if necessary, replace the gasket. Close the drain hole again.
- Top up new oil via the expansion tank (1) after removing the ventilation filter (2), until oil runs out from the level control opening (4) or the oil is filled up to mid-level of the sight glass (5). Always check the oil level immediately after commissioning and top up if necessary.
- Clean the sealing surfaces, clean, check and, if necessary, replace the sealing elements.
- Close the level control and filler holes again.

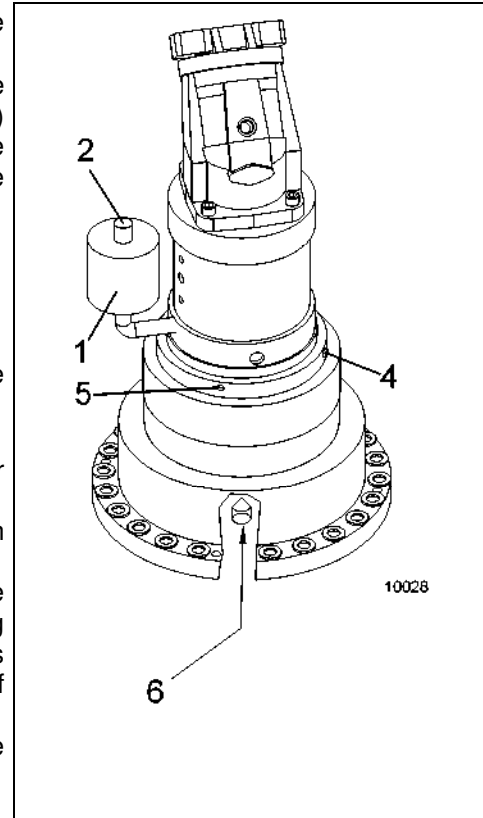

Always check the oil for foreign matter when it is being changed.  
Drain off the oil at the operating state temperature.

Overstraining and improper operation may be the causes for coarse particulate matter found in the oil. Find out and eliminate the cause. Uninstall the swing mechanism and check for damage. If necessary, get a general overhaul done from the manufacturer.

Check the oil for possible blackening and foreign material and reduce the oil change intervals if necessary.

##### 4.2.1 Checking the swing mechanism



#### CAUTION

##### Risk of accident due to loose screws!

The screws of the helical spring may become loose during prolonged continuous operation and in case of frequent maximum load on the swing mechanism.

a) Check whether all the screws in the load flow are tight.

- Check whether all the screw joints are tight.
- Check the swing mechanism for abnormal noise.

##### 4.2.2 Ventilation filter

- Check the ventilation filter (section 4.2, Pos. 2) for damage/soiling, clean and replace if necessary.

### 4.3 Checking hydraulic oil in the working brake circuit of the swing mechanism

- The supply tank (3) must be filled with **hydraulic oil** up to the gauge mark.

	<b>NOTE</b>
	<p><b>The service brake does not operate!</b> If the oil level in the slewing gear brake is too low, the slewing gear brake cannot be released.</p> <ol style="list-style-type: none"> <li>1) Rectify the oil loss in the slewing brake.</li> <li>2) Top up the supply tank and do not use any brake fluid.</li> <li>3) Bleed the braking system.</li> </ol>

#### 4.3.1 Bleeding the working brake circuit

The working brake must be bled after carrying out repair work on the hydraulic parts of the working brake circuit and before commissioning the gearbox.

- Fill the supply tank (3) in the crane cab with hydraulic oil.
- Remove the protective cap from the bleeder valve (1).
- Put on the transparent hose on the bleeder valve and open the valve by approximately one turn.
- Suspend the hose in a glass half-filled with hydraulic oil.
- Pump with the foot pedal (2) until oil without air bubbles starts coming out from the hose.

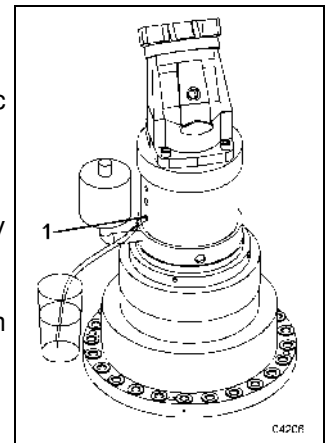

	<b>NOTE</b>
	<p><b>Air in the braking system!</b> If adequate oil is not available in the supply tank to supply the bleeding process, air may enter the braking system.</p> <ol style="list-style-type: none"> <li>1) Check or top up the oil level in the supply tank continuously during the bleeding process.</li> </ol>

- Close the bleeder valve, remove the hose and put on the protective cap when the foot pedal is pressed.
- Leave the foot pedal only when the bleeder valve is closed.
- Check the hydraulic oil level in the supply tank again.

**Functional check:** The foot pedal may not have any unallowable dead play or be springy or floored too much; it must be bled again if necessary.

Dispose the waste oil in an eco-friendly manner.

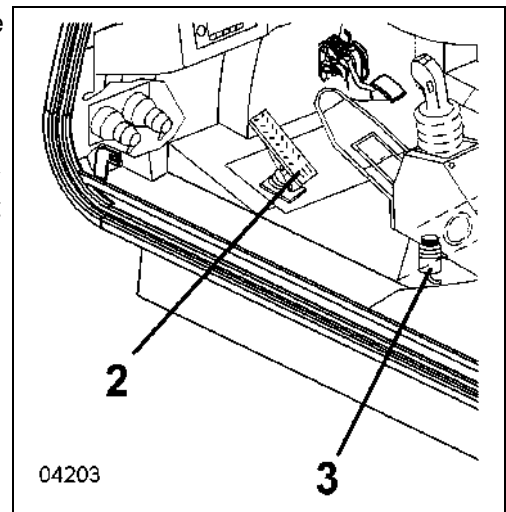

### 4.3.2 Checking the slewing gear brake

Check the functioning and leak tightness during the operation. An internal check for wear should be conducted once a year.

Please contact your TADANO After-Sales Service in case of queries or problems. It will gladly carry out all the servicing, maintenance and repair work that crops up.

### 4.4 Checking the slewing engine – gear drive shaft, tooth profile play

The slewing engine and brakes should be removed once a year and the splined shaft connection at the drive end must be checked.

There may be no excessive tooth profile play.

The tooth profiles have a smooth, bright and shiny surface after the running-in period in case of normal wear. In case of all other features, such as abrasive wear, grooves, seizures, pit marks, exfoliations, chips, cracks and plastic deformations, the gear wheels must be replaced.

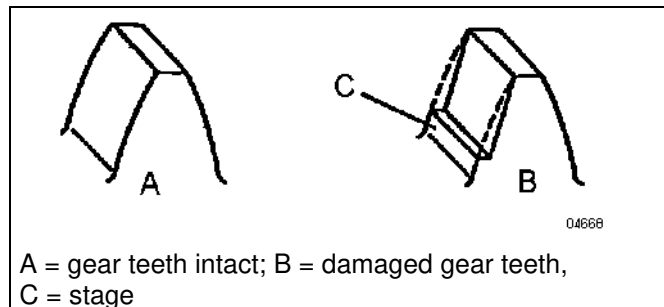

Please contact your TADANO After-Sales Service in case of queries or problems. It will gladly carry out all the servicing, maintenance and repair work that crops up.

### 4.5 Lubricating swing mechanism gear rings and pinions

The greasing intervals depend on the slewing frequency. The special lubricant is applied on the gear teeth with a brush or a spray. See to it that there are no exposed points on the tooth profiles.





Check the swing mechanism gear ring and pinion lubrication every time after cleaning the device – particularly after having used a steam cleaner. The gear ring and pinion must always be lubricated.

#### 4.6 Lubricating the ball-bearing slewing ring

	The ball-bearing slewing ring is lubricated with the help of a central lubricating system.
---	--

- Shorter lubricating intervals in tropical zones, in case of high atmospheric humidity, large amounts of dust and dirt as well as significant temperature change.
- Lubrication is a must before and after longer decommissioning.
- Be careful when cleaning the mobile crane; no water should seep into the raceways.
- Lubricate all over properly after cleaning.
- Always lubricate amply such that an entire grease collar is formed around the bearing gaps.
- Support the mobile crane and turn the superstructure so as to achieve equal distribution of the grease when lubricating.

	 <b>DANGER</b>
	<p><b>Danger of accidents due to overturning!</b> The mobile crane may overturn while turning. This can cause injuries to persons, which could sometime be fatal.</p> <p>1) The superstructure may be turned only when the mobile crane is supported.</p>

#### 4.7 Greasing the swing mechanism – lock pins

- The lock pins for the superstructure interlock must always be smooth.
- Grease the pins regularly.

#### 4.8 Checking the functioning of the mechanical superstructure lock and proximity switch

The superstructure is locked using lock pins. A proximity switch is there in the carrier for checking purposes. The functioning of the lock and proximity switch should be checked before starting any crane work. If the “Swing Mechanism Locked” icon lights up in the Control and Service System on actuation, it could be because of the following reasons:

- Locking was not done properly.
- Icon is defective.
- Proximity switch in the carrier is defective.

#### 4.9 Lubrication of the swing mechanism multi-disc chamber

0.1 l hydraulic oil is filled before installing the engine for ensuring corrosion protection in the multi-disc chamber and for achieving a constant friction coefficient.

It is not necessary to change the oil in the multi-disc chamber.

However, see to it that the same oil grade and quantity is re-filled after repairs or after replacing the discs before the subsequent installation of the engine.

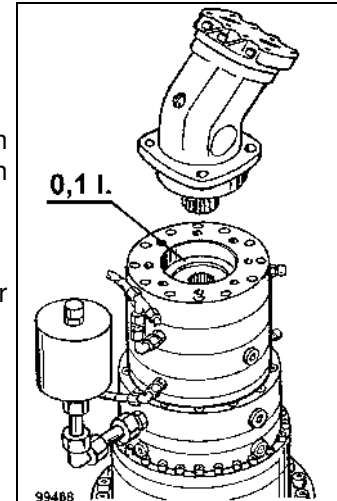

#### 4.10 Checking the gear ring-joint screws, fastening screws of the hydro motor, gear flange screws for firm fit

- Check the screws of the slewing ring, the hydro motor and gear flange screws with a torque wrench for firm fit as per the maintenance schedule and tighten them if necessary.

Tightening torque of the:

- Gear ring joint screws M 30 =  $1805 \pm 95$  Nm,
- Gear ring joint screws M 24 =  $912 \pm 48$  Nm,
- Fastening screws of the hydro motor M 10 =  $65 \pm 3$  Nm,
- Gear flange screws M 16 =  $266 \pm 14$  Nm.

#### 4.11 Checking the slewing ring for wear

The wear of the raceway system and the tipping backlash of the slewing ring increase over years of operation.

**The maximum permissible increase in the bearing clearance is 2.9 mm, measured under the raceway. The specified value is not the absolute value, but describes the increase in the play relating to the bearing clearance in the new condition.**

	<b>! DANGER</b>
	<p><b>Risk of accidents due to excessive bearing clearance!</b>          In case of any suspicion of impermissible increase in the tipping backlash or progressed wear, please contact TADANO After-Sales Service.</p>



## 5 Hoisting gear / 2nd hoisting gear\*)

	<p><b>! WARNING</b></p>
	<p><b>Risk of falling!</b> The maintenance personnel can fall and get seriously injured when carrying out maintenance work from an elevated place.</p> <ol style="list-style-type: none"> <li>1) Secure the personnel against falls with suitable aids (e.g. platform, railing) when carrying out maintenance work on the mobile crane.</li> <li>2) Use the existing access steps and ladders.</li> </ol>

	<p><b>! DANGER</b></p>
	<p><b>Risk of accident due to unintentional commissioning!</b> People may get injured or die due inadvertent commissioning of the mobile crane. Keep in mind the following points when carrying out the servicing and maintenance work:</p> <ol style="list-style-type: none"> <li>1) Work on the hoisting gear / 2<sup>nd</sup> hoisting gear only in case of standstill and load-free state.</li> <li>2) Take protective measures against unintentional commissioning before starting the work.</li> <li>3) Ensure that no persons are present in the danger zone before commissioning after the maintenance or repair work.</li> </ol>

### 5.1 Checking the oil level and leak tightness

- Check the hoisting gear regularly for leak tightness as per the maintenance schedule.
- Defective gaskets can reduce the service life of the hoisting gear.
- Oil leakage or very low oil level in the gearbox can lead to damage.

- Check the oil level regularly as per the maintenance schedule when the gearbox is at a standstill and the oil has cooled off.
- The oil level must be between both the markings, minimum and maximum, on the sight glass (1). If necessary, replenish with the relevant oil via the filler plug (3) by means of a funnel or hose.
  - Check the oil level again and top up if necessary.
  - Clean the sealing surfaces, clean, check, and if necessary, replace the sealing elements.
  - Close the filler holes again.

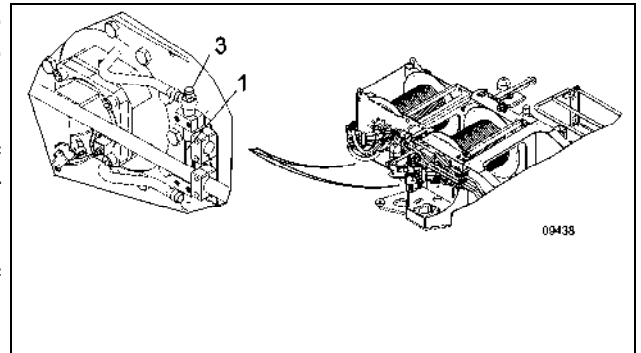

	<p><b>NOTE</b></p>
	<p><b>Malfunctions due to mixing of oils!</b> Mixing the different oil types may lead to malfunctions in the hydraulic system.</p> <ol style="list-style-type: none"> <li>1) Do not mix oils of different manufacturers, types and grades.</li> </ol>

## 5.2 Oil change

- Change the oil regularly as per the maintenance schedule at the operating state temperature.

	<b>! CAUTION</b>
	<b>Hot oil in the hoisting gear / 2<sup>nd</sup> hoisting gear*)!</b> Risk of scalding due to hot oil. 1) Let the oil cool to a value below 40 °C.

- Unscrew the filler plug (3) and drain plug (2).
- Allow the oil to drain off in a suitable container.
- Clean the sealing surfaces.
- Clean, check and, if necessary, replace the gaskets of the drain plug (2) and re-screw in the drain plug (2).
- Top up new oil through the filler plug (3) by means of a funnel or hose until the oil level on the sight glass is between the minimum and maximum markings.
- Clean the sealing surfaces, clean, check, and if necessary, replace the gasket of the filler plug (3) and screw it in again.
- Check the oil level again and top up if necessary.

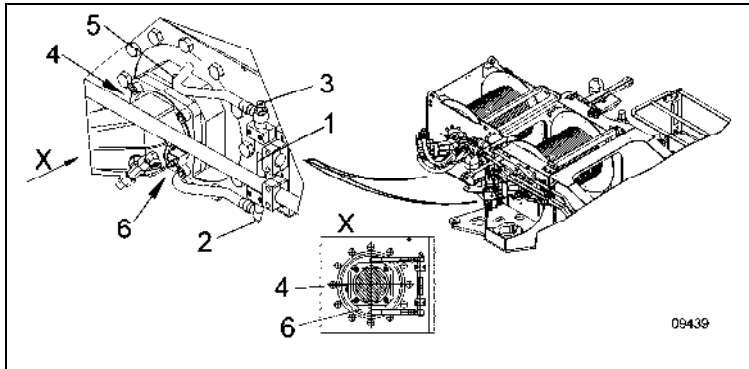

<b>i</b>	Always check the oil for foreign matter when it is being changed. Drain off the oil at the operating state temperature.
----------	--

Overstraining and improper operation may be the causes for coarse particulate matter found in the oil. Find out and eliminate the cause. Uninstall the swing mechanism and check for damage. If necessary, get a general overhaul done from the manufacturer.

Check the oil for possible blackening and foreign material and reduce the oil change intervals if necessary.

## 5.3 Checking the oil level in the hoisting gear motor-engine coupling

The oil level must be checked regularly as per the maintenance schedule.

- Open the oil level control plug (4) on the overflow tap. The oil level must be up to the lower edge of the overflow tap. Replenish oil (see oil recommendation) via the filler hole (5) if necessary.

## 5.4 Changing the oil in the hoisting gear motor/engine coupling

The oil must be changed regularly as per the maintenance schedule.

- Allow the oil to drain off via the drain plug (6).
- Check the oil for impurities. The splined shaft connection must be checked if granular abrasion or flattenings of the tooth profiles are found.
- Top up new oil through the oil filler hole (5) until the oil starts coming out from the overflow tap.

## 5.5 Checking the hoisting gear motor-gear drive shaft, tooth profile play

The hoisting gear motor and brakes should be removed once a year and the splined shaft connection at the drive end must be checked.

There may be no excessive tooth profile play.

The tooth profiles have a smooth, bright and shiny surface after the running-in period in case of normal wear. In case of all other features, such as abrasive wear, grooves, seizures, pit marks, exfoliations, chips, cracks and plastic deformations, the gear wheels must be replaced.

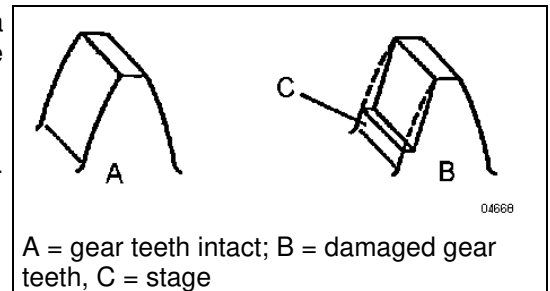

Please contact your TADANO After-Sales Service in case of queries or problems. It will gladly carry out all the servicing, maintenance and repair work that crops up.

## 5.6 Preserving the hoisting gear drive

It is recommended that the hoisting gear be preserved in case of prolonged lack of use of devices.

- Drain off the waste oil and fill up half the quantity of the preservative oil.
  - Wind and unwind the hoisting gear for approximately 5 - 10 minutes without load in case of a large number of cut-ins.
  - Drain off the preservative oil when recommissioning and top up with the prescribed oil.
- Only the preservative oil that is emulsified with lubricating oil as per the oil manufacturer's specifications may be used (keep the oil recommendations in mind).

## 5.7 Check the hoisting gear brake

The hoisting gear brake should be checked for wear once a year.

The hydro multi-disc brake of the hoisting gear is subject to a certain amount wear. Unscrew the hoisting gear flange and the engine for checking and replace the complete set in case of wear.

At the same time, the free wheel of the hoisting gear brake must also be checked.

The following procedure must be followed:

In order to check the free wheel, a load that amounts to 125% of the maximum rope traction force must be adjusted on the short boom by raising and suspending just above the ground. The resulting distance between the raised load and the ground should not change within 15 minutes.

However, also see to it that the derrick cylinder angle does not change on account of the temperature influences. The free wheel must be replaced once the load is lowered.

## 5.9 Checking the anti-twoblock device function

The anti-twoblock device prevents the bottom block from running into the sheaves.

- Raise the bottom block till the release weight (1) is lifted and the spring-loaded limit switch (2) is released.

**The "Hoisting Gear On", "Extend Telescope" and "Derricking Off" crane movements must now shut off.**

- Lower the bottom block again until the release is freely suspended; all the crane movements are possible again.

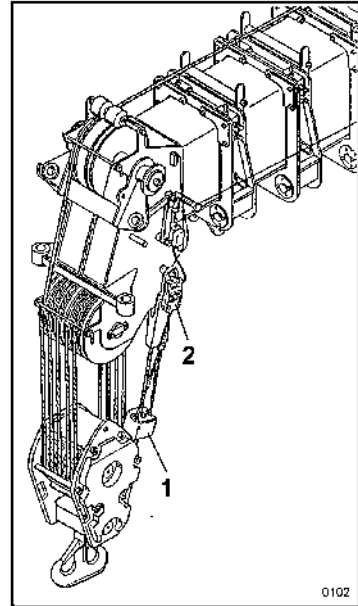

## 5.10 Check the over-unwind limit switch on the hoisting gear

The over-unwind limit switch is set such that at least **three** turns of the rope remain on the drum for safety reasons.

- Extend telescopes and unwind rope until at least **three** turns of the rope remain on the winch drum.

**The hoisting gear must now shut off.**

<b>i</b>	Check the winch drum and rope grooves for wear before winding. If necessary, check the rope and lubricate it when winding.
----------	--

### 5.10.1 Setting the over-unwind limit switch

- Wind at least 3 turns of the rope on the drum.
- Unscrew the cover plate (1).
- Twist the gear cam disc (2) with the set screw (3) until the cam (4) actuates the microswitch (5) (audible click in the switch).

The gear cam disc is maintenance-free.

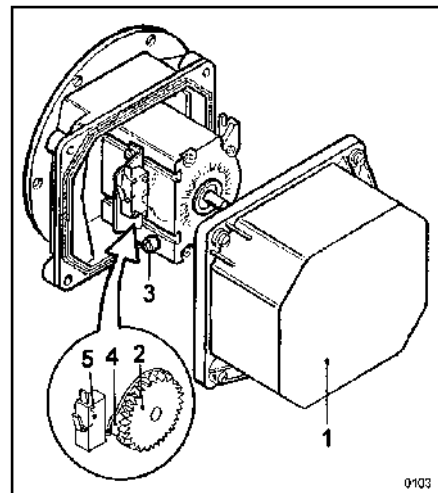

## 6 Hoisting rope

	<b>! WARNING</b>
	<p><b>Maintenance work without adequate safety precautions!</b></p> <p>There is an increased risk of falling when carrying out maintenance work from an elevated place without adequate safety precautions. This may cause injuries, which could even be lethal sometimes.</p> <ol style="list-style-type: none"> <li>1) The personnel must be protected with suitable aids (e.g. platform, railing) when carrying out maintenance work on the mobile crane.</li> <li>2) Use the existing access steps and ladders.</li> </ol>

### 6.1 Check

- Check the hoisting rope visually before and after every operation.
- The legal regulations (as per DIN 15020 sheet 2 and VBG 9a in Germany) must be followed strictly during regular evaluation and periodic rechecks of the hoisting rope.
- Hoisting ropes need to be replaced if rope breakage, breaking of a strand, bird-caging, crushing, rusting, wear, reduction of the rope diameter, permanent deformation, etc. are found.
- Check the entire length of the hoisting ropes and its attachments as well.

Further information: see section Crane testing instructions for the superstructure, Checking the hoisting ropes.

### 6.2 Cleaning and lubricating the hoisting rope

- Spray clear water on coarsely soiled hoisting ropes and grease them after drying to extend their service life. Grease the hoisting rope with adhesive grease to protect it from water and against rust formation.
- It is not enough to grease the hoisting rope on the surface only. The lubricant must penetrate into the rope.
- Keep the lubricant recommendation in mind.

	<p>In order to increase the service life, keep the hoisting rope clean and do not drag it over the floor.</p>
---	---

### 6.3 Laying the hoisting rope (rope change)

- Place the bottom block on the ground.
- Unbolt and dismount the rope socket.
- Remove the hoisting rope from the hoist limit switch weight and pull it out of the bottom block and pulley.
- Unwind the hoisting rope till the hoisting gear end switch is switched off.
- Loosen the remaining windings.
- Remove the rope end by loosening the threaded pins (1) on the clamping bar (2).
- Remove the hoisting rope.

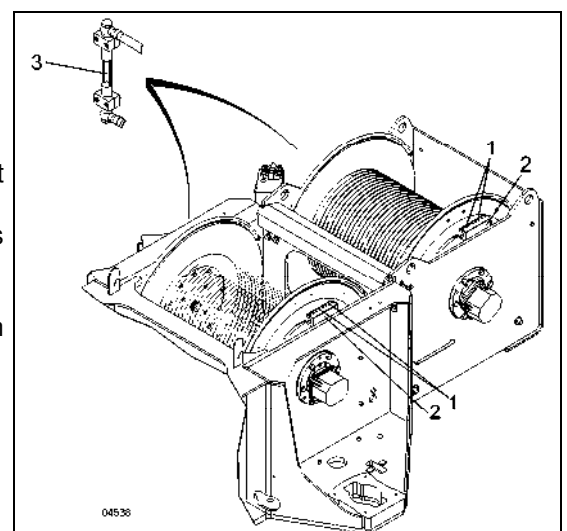

## 6.4 Checking the winch drum

- Check the winch drum once before laying a new hoisting rope of the same type (see crane test book).
- Properly clean the drum of dirt, old colours and foreign materials.
- Check the wear of the winch drum grooves.
- Check the oil level on the sight glass (3) if necessary.

## 6.5 Laying a new hoisting rope

<b>i</b>	The service life of a hoisting rope is decisively influenced when at the time of laying the rope. Use hoisting ropes of the same type, strength and diameter when they are changed.
----------	---

- Preferably work with a winch bracket under the boom head.
- Technical data hoisting ropes is given in the crane test log (corresponding pages can be procured from den TADANO After-sales Service).
- Take the rope end over the boom head and pull it through to the winch drum.
- Take the rope end through the hole of the clamp (2) and tighten the threaded pins (1); tightening torque 60 Nm.
- Unwind approximately 6 rope windings, unwind the rope till the anti-twoblock device switches off at 3 windings and reset the switch if necessary.
- Wind up the hoisting rope slowly on the winch drum (lay the rope under pre-charge pressure).
- Tap the hoisting rope in the right position with brass or a lead hammer only.
- Proper accumulation on the drum is ensured only through correctly selected directions of laying.
- See to it when accumulating that the hoisting rope is accumulated such that it is tightly tensioned (lubricate the rope if necessary).
- Take the rope through the anti-twoblock device weight, cut-in in the bottom block and attach it to the rope socket.

<b>i</b>	Move the new hoisting rope with just a little load initially and gradually increase to maximum load so that the hoisting rope can shrink, set and stretch.
----------	--

## 6.6 Servicing the hoisting rope

- The safety of the crane operation must be maintained through regular servicing and the service life of the hoisting rope must be increased considerably.
- Wire ropes must be lubricated at regular time intervals, which depend on the operating ratios, particularly with respect to the bending areas on the drums and sheaves. The lubricant must be compatible with the original rope lubrication.
- Well-lubricated ropes result in four times the flexing cycles than unlubricated ropes under the same test conditions.
- Severely soiled wire ropes should be cleaned regularly, ideally using brushes or by washing with clear water.
- If the lower rope positions on the drum are hardly or never used, they must be unwound from time to time and laid again under pre-charge press. The hoisting rope is most efficient when its entire length is used. Therefore, it is recommended that a correspondingly adjusted rope length is used during prolonged crane work.
- The hoisting rope must be inspected regularly, particularly when the rope is newly laid. It must also be inspected after unusual loads, for probable, unnoticeable damage or in case of first signs of rope damage.
- If the same lift is operated frequently, shift the hoisting rope in the longitudinal direction from time to time if necessary.

## 7 Electrical system

	<b>NOTE</b>
	<p><b>Material damage!</b> When working on the electrical system, the circuit must be interrupted by disconnecting the minus pole cable from the batteries (marked on the battery with a minus sign [-]).</p>

### 7.1 Checking the batteries

	<b>WARNING</b>
	<p><b>Risk of injuries!</b> Batteries emit highly explosive hydrogen gas due to chemical reactions. Battery acid should never come in contact with the skin, clothing or vehicle paint. Risk of injuries due to battery acid.</p> <ol style="list-style-type: none"> <li>1) Wear protective glasses.</li> <li>2) Do not smoke or use open flame when checking the acid level!</li> <li>3) In case of any contact with the skin or eyes, rinse the affected area with lots of clear water and see a doctor if necessary.</li> </ol>

	<b>NOTE</b>
	<p><b>Environmental pollution due to battery acid and heavy metals!</b> Battery acid and heavy metal components of the battery may pollute the environment.</p> <ol style="list-style-type: none"> <li>1) Dispose old batteries in an eco-friendly manner.</li> </ol>

The batteries are located on the right side of the superstructure (seen in the driving direction) in front below the cover.

The lid of the maintenance port (1) must be opened for servicing the batteries.

There are just a few maintenance requirements under normal operating conditions.

A properly charged battery contributes to a better start operation and a longer service life of batteries.

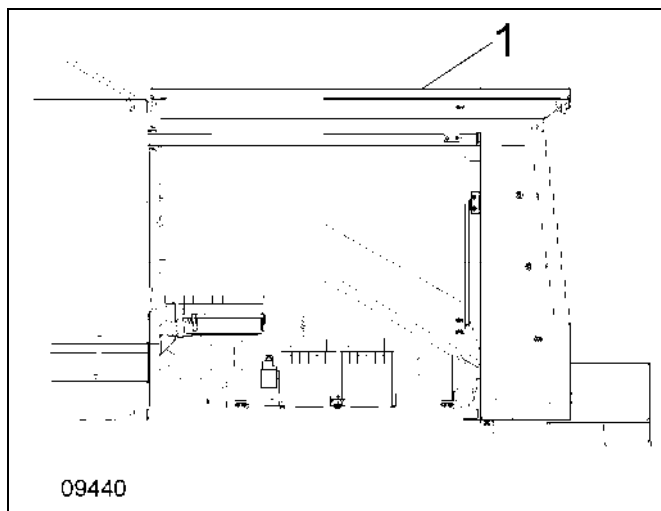

- Check the acid level regularly (visual check). The acid level must be approximately 10 - 15 mm above the upper edge of the cell.
- Replenish with distilled or demineralised water only. After replenishing, wait for approximately 30 minutes before checking the acid level.
- Measure the acid density in the individual cells with an acid siphon.

### 7.1.1 Specific weight and charge condition of the battery at +20 °C acid temperature

Specific weight		Volt per cell	Charge condition of the battery
Normal	Tropical zone	On the tester	
1.28	1.23	2.4	Charged
1.20	1.12	2.0	Semi-charged - recharged
1.12	1.08	1.75	Discharged – Charge immediately



The changes in the acid density must be considered when using the mobile crane in tropical zones. Monitor the acid temperature continuously when charging.

- Always pay attention to a good charge condition in winters. If the mobile crane is idle for a prolonged time, the batteries need to be recharged.
- The charging current may amount to a maximum of 1/10 of the battery capacity.
- Grease the connecting terminals slightly with acid-free and acid-resistant grease (e.g. Vaseline).
- Electroconductive parts such as tools, etc. may not be placed on the batteries because of a danger of short-circuiting.
- The batteries are not charged if the battery charging pilot lamp does not turn off at higher engine speed. Repair the cause immediately (controller or generator).

### 7.1.2 Installing new batteries

- Connect the **positive cable (+) first** and then the negative cable (-) when installing new batteries.
- Proceed in the **reverse order** when **removing the battery**.

## 7.2 Three-phase generator

The service life of the three-phase generator is determined with the storage condition. Therefore, always ensure that correct Vee belt tension is used (see the operating manual of the engine manufacturer).

- Get the generator checked in a specialist workshop at regular intervals. It needs to be done earlier in case of severe dust accumulation or high ambient temperatures.
- Operate the generator only with the controller and when the batteries are connected.
- Ensure the correct polarity when connecting the batteries, otherwise the diodes in the generator may get damaged.
- Carry out the installation work on live parts only when the engine is at a standstill and the batteries are disconnected (precautionary measure).
- Do not dab against the earth to check whether the current is available.
- The generator is pre-excited by the batteries and this is indicated using the charging indicator lamp. A damaged charging indicator lamp must therefore be replaced to ensure the proper pre-excitation.

## 7.3 Starter

Keep in mind the instructions of the engine manufacturer.



## 7.4 Lamps and lights

Replace defective lamps, pilot lamps and warning lamps immediately. Always use the same wattage.

### 7.4.1 Place of installation, wattage and name of the lamps and lights in the superstructure

Place of Installation	DIN	Design	Wattage
Working floodlight (cabin, boom)	72601	YC	24V 70 W
Working floodlight* (boom)		G 6.35	24V 250 W
Flashing beacon	72601	H1	24V 70 W
Instrument panel (switch)	72601	W5/1.2	24V 1.2 W
Cabin, interior light	72601	K	24V 10 W
Lateral lights on the boom head	72601	H	24V 2 W

## 7.5 Automatic Safe Load Indicator (ASLI)

**The automatic safe load indicator primarily comprises electronic assemblies in a modular system. Only service personnel of TADANO may carry out maintenance and repair work.**

The crane operator must check the following every time before using the crane:

- The functioning of the ASLI is not restricted due to external damage,
- The anti-twoblock device is attached correctly to weight and chain,
- The electric cable connectors are inserted,
- The electro-cable drum is rolled and tensioned correctly and also has a clean cable guide,
- The cable is not damaged or does not have strand breaks.



### 7.5.1 Checking the feed of hydraulic pumps

	<b>NOTE</b>
	<p><b>Malfunctions in the crane control!</b>                      Malfunctions may occur in the crane control owing to incorrect feed quantities of hydraulic pumps. This may lead to accidents involving material damage and/or personal injuries</p> <p>1) Check the feed of hydraulic pumps.</p>

The automatic safe load indicator (ASLI) uses the feed values of hydraulic pumps for computing the data. The correct feed of hydraulic pumps is therefore a prerequisite for a flawless functioning of the crane control. After carrying out the prescribed maintenance work on the hydraulic system and the automatic safe load indicator (ASLI), the pump must be compensated.



## 7.6 Regular inspection of the automatic safe load indicator (ASLI) as per the legal regulations

- Test the systems with checked weights regularly corresponding to the legal regulations.
- If a considerable deviation from the basic setting is found, it must be re-adjusted by an expert.

	 <b>DANGER</b>
	<b>Improper work on the automatic safe load indicator (ASLI)!</b> Improper maintenance work on the automatic safe load indicator (ASLI) leads to faults or failure. 1) Any intervention of unauthorised persons in the automatic safe load indicator (ASLI) electronics is prohibited.

## 7.7 Fuse and relay chart

Fuses are provided at the rear side of the crane cab and in the battery compartment.

	 <b>CAUTION</b>
	<p><b>Risk of damage to the electrical system!</b> Switch off the ignition before replacing defective fuses. Replacing the fuses with bypassing using a wire or similar is prohibited.</p> <p>1) Replace defective fuses only with fuses of same current!</p>

Function	Fuse	Amperage
ADM	F804	10A
ADM	F805	10A
ADM	F833	10A
Display of Automatic Moment Limiter	F821	15A
Working floodlights, boom	F827	10A
Working floodlights, boom adjustable via motor <sup>1)</sup>	F827	25A
Working floodlight, cab	F826	15A
Working floodlight, winch	F829	7.5A
Armrest	F820	10A
Access plate adjustment	F802	15A
removal of boom	F853	7.5A
Outside temperature	F854	15A
Battery main switch	F843	5A
CGC	F804	10A
CGC supply	F832	10A
Removal of luffing fly jib	F849	7.5A
Engine diagnosis	F807	10A
Engine diagnosis	F834	10A
Swing range limitation	F822	10A
Swing brake	F838	10A
Gearbox of swing mechanism	F813	10A
Pressure sensor	F813	10A
EN13000 <sup>*)</sup>	F852	10A
Aircraft warning lamp	F830	3A
Counterweight	F819	7.5A
Generator	F835	7.5A
Heater fan	F823	15A
Hoist limit switch	F811	3A
Hoisting gear	F822	10A
Cab light	F831	3A
Instrument illumination	F826	15A
Air conditioning <sup>*)</sup>	F840	20A
Crane control	F822	10A
Crane control	F824	5A
Crane control, Automatic Moment Limiter	F839	10A
Crane control, rope winches	F809	10A
Crane control, emergency mode	F838	10A
Automatic Moment Limiter	F813	10A
LCD monitor	F848	15A
Solenoid valve control pressure	F820	10A
Engine stalling device – outside temperature <sup>*)</sup>	F806	5A
MR	F805	10A
Crane control, emergency mode	F818	15A
Telescope emergency mode	F818	15A
Oil cooler	F836	20A
Oil cooler with supplementary oil cooler	F836	40A
Radio	F844	15A
Electric horn	F808	7.5A
Seat	F802	15A
Mirror heating system	F803	10A

Function	Fuse	Amperage
Plugbox 12V	F844	15A
Plugbox for inspection lamp	F837	10A
Telescope control system	F816	10A
Telescope control system, length transmitter	F817	5A
Swing override feature, counterweight	F824	5A
Automatic Moment Limiter override feature	F815	7.5A
Carrier control system	F856	7.5A
Valve, Automatic Moment Limiter	F847	7.5A
Fan	F831	3A
Precontrol transmitter, left-hand	F812	3A
Precontrol transmitter, right-hand	F812	3A
Warning buzzer, engine	F804	10A
Washer	F801	10A
Winch angular momentum encoder	F814	7.5A
Anemometer.	F846	3A
Angle transmitter	F846	3A
Luffing fly jib**)	F810	5A
Luffing fly jib *)	F851	3A
Wiper	F801	10A
Timer, heating	F823	15A
Central electrical system	F821	15A
Central electrical system, Automatic Moment Limiter	F845	3A
Central electrical system, Automatic Moment Limiter	F825	3A
Centralized lubrication system	F803	10A
Supplementary heater unit	F841	20A
Supplementary heater unit	F842	5A

MR / ADM = Electronic system, engine;  
 AML = Automatic Moment Limiter;  
 F = Fuse;  
 DA = Pressure sensor;

CGC = Control and Service System  
 ZE = Central electrical system;  
 MV = Solenoid valve;  
 DWG = Swing angle transmitter.

\*\*) Optional equipment

Relays are provided at the rear side of the crane cab and in the relay box for the counterweight control.

Function	Relay / Diode / Plug	Mounting location
15+ ADM/MR	K813	Relay plate A
Shut-off of crane control at an outside temperature of -25°C *)	K827	Relay plate B
AML shut-off feature	K919	Relay plate B
Amot-Control*)	K860	Relay plate B
Working floodlight	K808	Relay plate A
Armrest	K934	Relay plate B
Battery main switch	K803	Relay plate A
CGC supply	V803	Relay plate A
CGC supply	K812	Relay plate B
Swing brake	K828	Relay plate C
Counterweight	V905	Relay plate B
Counterweight	V920	Relay plate B
Counterweight support	K929	Relay plate B
Generator D+	K809	Relay plate A
Heating/fan	K811	Relay plate A
Air conditioning *)	K817	Relay plate A
Air conditioning *)	K816	Relay plate A
Crane control ON	K941	Relay plate C
Crane control; emergency mode	V937	Relay plate C
Crane control; emergency mode	V911	Relay plate C
Crane control; emergency mode	V912	Relay plate D
Crane control; emergency mode	V913	Relay plate D
Crane control, emergency mode / slewing to the left	K959	Relay plate D
Crane control, emergency mode / slewing to the right	K960	Relay plate D
Crane control, emergency mode / swing brake	V914	Relay plate C
Crane control, emergency mode / swing brake	K963	Relay plate D
Crane control, emergency mode / hoisting gear 1 down	K952	Relay plate D
Crane control, emergency mode / hoisting gear 1 up	K953	Relay plate D
Crane control, emergency mode / hoisting gear 2 down	K961	Relay plate D
Crane control, emergency mode / hoisting gear 2 up	K962	Relay plate D
Emergency mode / extending telescopes	K951	Relay plate D
Emergency mode / extending telescopes	K957	Relay plate D
Emergency mode / retracting telescopes	K958	Relay plate D
Crane control, emergency mode / boom elevation down	K955	Relay plate D
Crane control, emergency mode / boom elevation up	K954	Relay plate D
Crane control, fly jib	K985	Relay plate B
Crane control, control pressure	V904	Relay plate B
Crane control, emergency mode	K950	Relay plate C
Crane control, emergency mode / retracting telescopes	K973	Relay plate C
Radiator control	K801	Relay plate A
EMERGENCY OFF	K819	Relay plate B
Emergency mode, telescopes	V915	Relay plate C
Electric horn	K814	Relay plate A
Telescope control, emergency mode	K970	Relay plate C
Telescope control, emergency mode	K971	Relay plate C
Telescope control, emergency mode	K964	Relay plate C
Telescope control, emergency mode	K972	Relay plate C
AML override feature	V907	Relay plate C
Luffing fly jib	K995	Relay plate B
Luffing fly jib	K996	Relay plate B
Wiper, skylight	K803	Relay plate A
Windscreen wiper	K802	Relay plate A

ADM / MR = Electronic system, engine;  
 AML = Automatic Moment Limiter;  
 MPKT = Ground point;

CGC = Control and Service System;  
 K = Relay;  
 V = Diode.

P 911 = Diagnostic plug, AML display
P 910 = Diagnostic plug, AML
P 820 = Diagnostic plug, engine

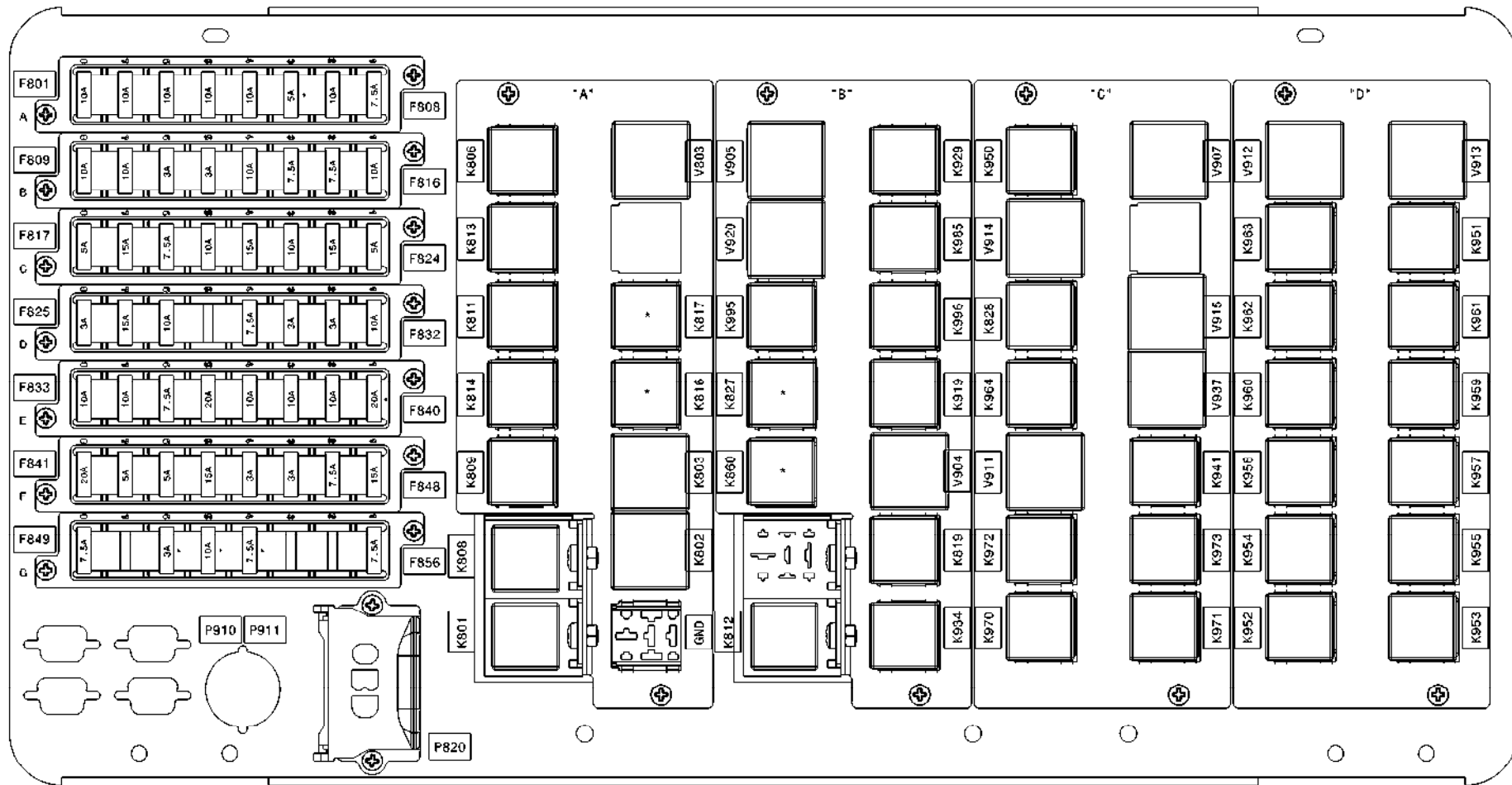

\* = Optional equipment

99707027102  
A/0511

## 7.7.1 Fuses in the battery compartment

1 = F 863 charging socket fuse*)	<b>25 A</b>
2 = F 862 battery fuse +	<b>25 A</b>
3 = F 861 battery fuse +, battery main switch	<b>50 A</b>

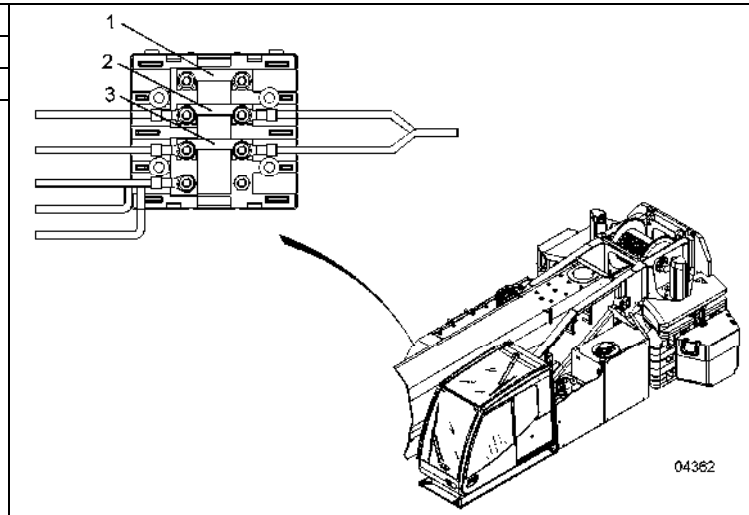

7782218  
B/0704



7.8 Counterweight control relay chart

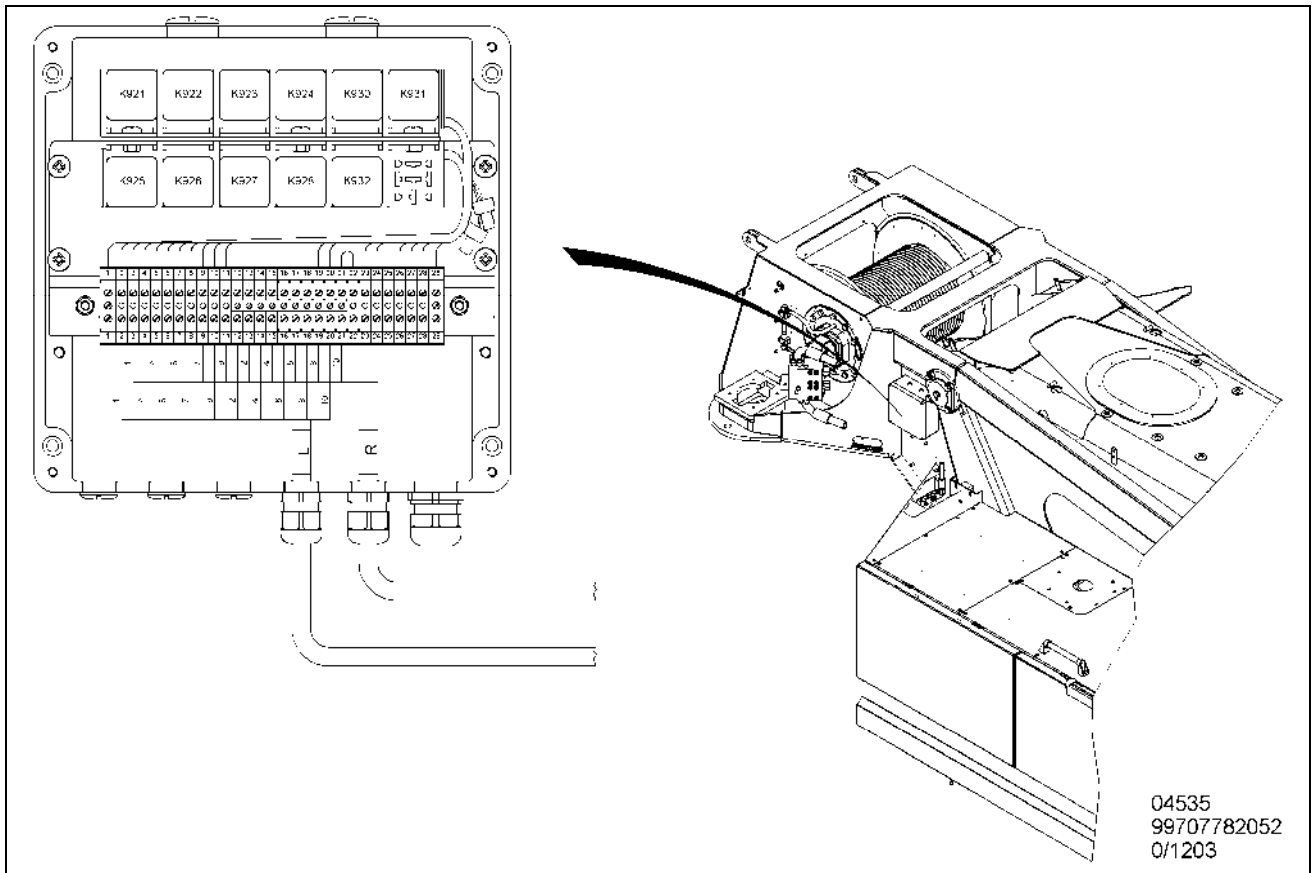

Relay

K 921	=	Counterweight below
K 922	=	Counterweight below
K 923	=	Counterweight is not on top
K 924	=	Counterweight is not on top
K 930	=	Counterweight is not on top
K 931	=	Counterweight is not on top
K 925	=	Counterweight blocked
K 926	=	Counterweight blocked
K 927	=	Counterweight released
K 928	=	Counterweight released
K 932	=	Counterweight blocked

K = relay.

**Notes:**

## 8 Crane cab

Lubricate hinges and pins as well as all movable parts with lubricating oil. Pay attention to good mobility and utility of the parts.

For instance, this includes the following:



- Hinge-joints of the cover flaps and lids of the maintenance ports.

Service the mechanical parts of the door lock regularly. It is best if the lock cylinder is treated with a graphitic agent before the start of the frost period.

It is best if the door seals and other rubber parts are treated with acid-free grease or talc before the start of the frost period.

For more information about the crane cab, see documents provided by the device manufacturer in Part G, superstructure.

### 8.1 Air conditioning system\*)

	 <b>CAUTION</b>
	<p><b>Environmental pollution due to cooling agent!</b>  Special suction and filling stations, recovery stations, electronic leak searching devices and special tools are required for working on the air conditioning system. These are maintained only in specialist workshops. The disposal is also ensured in a specialist workshop only.</p> <p>a) All repairs, refilling or maintenance work on the air conditioning system may only be carried out in an authorised specialist workshop by competent personnel.</p>

#### Cooling compressor-oil level check:

The oil level in the compressor can only be checked after repairs or before re-filling the air conditioning system with a cooling agent. There may be no cooling agent in the circuit when checking the oil level.

Basically; the quantity of oil sucked out from the refrigeration circuit plus an additional quantity of 10 cm<sup>3</sup> must be re-filled into the circuit. If parts have been replaced during repairs, then also add the specified quantities for the replaced components (keep the current information of the factory in mind).

#### 8.1.1 Air condition - functional check

The air condition must be operated regularly, even in winters for approximately 10 minutes, so as to preserve the function standby.

An annual inspection must be carried out in a specialist workshop at the beginning of a cooling period.

## 8.2 Wiper-blade elements / windscreen washing system

### 8.2.1 Replacing the wiper-blade elements

The wiper-blades must be cleaned regularly so that they can perform their task properly. Owing to safety reasons (good visibility) it is advisable to replace the wiper-blades immediately in case of diminishing cleaning performance. The wiper-blades should be replaced once a year at least.

#### Replacing wiper-blades:

- Lift the wiper arm (1), remove the nut (2) and fastening screw (3) and take off the wiper blade.
- Mount the new wiper blade in the reverse order.

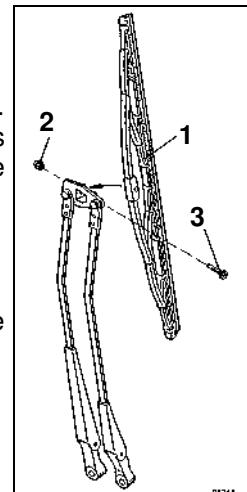

### 8.2.2 Windscreen washing system

The tank of the windscreen washing system is accessible after opening the windscreen.

## 8.3 Auxiliary heater

For instructions regarding the operation, servicing and maintenance of the heater, refer to the documents provided by the device manufacturer.

The manufacturer's specifications must be observed.

### 8.3.1 Replace the fuel filter

The auxiliary heater is provided fuel via the fuel tank. The fuel filter (3) of the auxiliary heater must be replaced regularly as per the maintenance schedule to ensure a smooth heating operation.

- Remove the cover (1).
- Loosen the hose clamps (2), remove the fuel filter (3), insert a new filter and screw on the hose clamps.

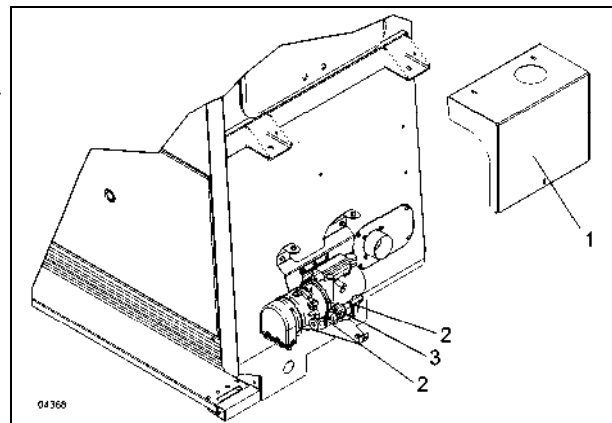

## 8.5 TADANO-Cockpit-Graphic-Control System

	<b>! DANGER</b>
	<p><b>Personal injuries due to improper repairs!</b>          Only qualified personnel may carry out the repairs. For replacing parts or components, use only those parts that have been specified in the spare parts list. Unauthorised opening and improper repairs may lead to death or severe physical injuries as well as considerable material damage.</p>

### 8.5.1 Monitor

The monitor of the TADANO-Cockpit-Graphi7-Control System should be cleaned regularly with a lint-free cloth depending on the dust accumulation.

### 8.6 Clean the circulating air filter

The circulating air filter (3) for the blower and air condition is located below the grid (2) in the floor assembly (1) behind the seat.

The circulating air filter (3) must be cleaned if it is visibly soiled with large dust particles.

The necessary cleaning intervals largely depend on the use of the crane.

The dirty element can be washed out with water and re-fit after drying.

The element must be checked for damage before fitting.

- Take of the grid (2) and remove the element (3).
- The cleaned and dried element is fit in the corresponding reverse order.

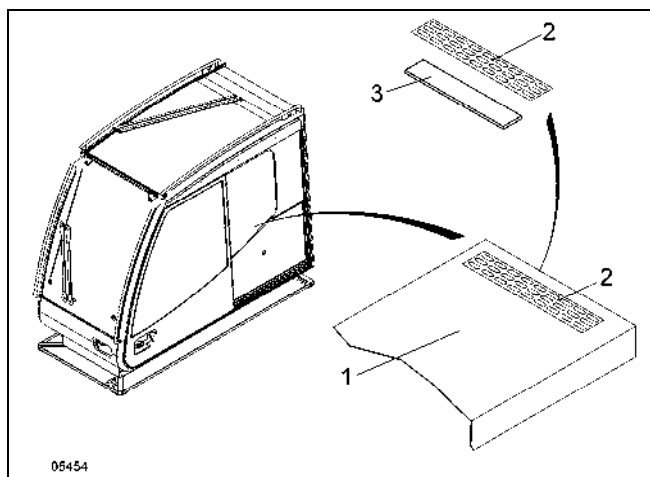

**Notes:**

## 9 Other greasing, maintenance and servicing points

### 9.1 Telescopic boom

- Lubricate and grease sliding pieces, slide coverings, sliding rails, horn cheeks and guide rollers, etc. regularly as per the maintenance schedule (keep the grease recommendations in mind).

<b>i</b>	The base boom bearing is lubricated with a central lubricating system.
----------	--

	<b>NOTE</b>
	<p><b>Risk of damage due to inadequate lubrication!</b>                  The grease on the lubricating points can be washed off when cleaning a vehicle with a steam-jet air ejector.</p> <ol style="list-style-type: none"> <li>1) Sliding surfaces, slide coverings, guide rollers, etc. must be checked after washing the vehicle and re-lubricated if necessary.</li> </ol>

#### 9.1.1 Lubricating the telescopes/locks

	<b>! DANGER</b>
	<p><b>Danger of accidents due to overturning!</b>                  The mobile crane may overturn when telescoping/derricking the boom. As a result, persons may get injured or be killed.</p> <ol style="list-style-type: none"> <li>1) The boom may be telescoped / derricked only when the mobile crane is supported.</li> </ol>

	<b>! WARNING</b>
	<p><b>Risk of falling!</b>                  The maintenance personnel can fall and get seriously injured when carrying out maintenance work from an elevated place.</p> <ol style="list-style-type: none"> <li>1) Secure the personnel against falls with suitable aids (e.g. platform, railing) when carrying out maintenance work on the mobile crane.</li> <li>2) Use available access steps and double ladders that have been provided.</li> </ol>

<b>i</b>	The Maintenance boom state must be selected as described in the ASLI operating manual for lubricating the telescope. The boom must be derricked to $\geq 20^\circ$ if there is a need for telescoping for reaching the lubricating points. The boom must be derricked back to the horizontal position even for the greasing process.
----------	---

- Boom has been retracted and derricked completely.
  - Remove the plugs.
  - Grease the slide coverings – above the boom – via the lubricating points (1) as per the maintenance schedule.
  - Attach the plugs again.

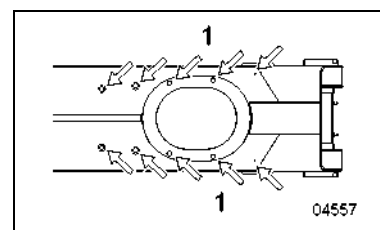

- Derrick boom  $\geq 20^\circ$ , extend the 2 telescopes until the lubricating surfaces for booms are completely accessible laterally and from below (3). Derrick the boom in horizontal position.
- Grease the sliding surfaces – lateral and below the boom – as per the maintenance schedule.
- Repeat the process till all the sliding surfaces have been lubricated.

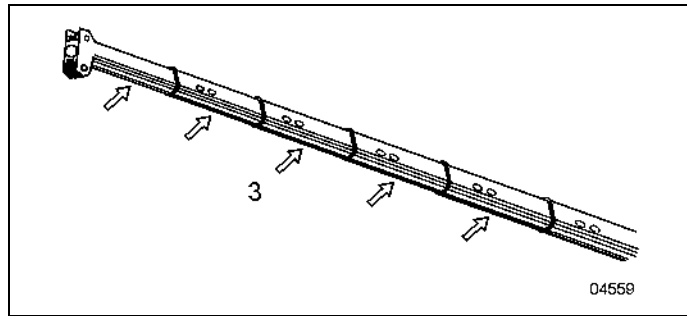

## 9.2 Derrick cylinder



The derrick cylinder bearing is lubricated with the help of a central lubricating system.

Clean the visible area of the piston rod of the elevation cylinder in accordance with the maintenance schedule and coat it with "Lube Protection Spray" (in transport position).

Reduce these intervals if the mobile crane is operating in aggressive air (e. g. in salty air at the seaside). The piston rod of the elevation cylinder must be cleaned and coated with "Lube Protection Spray" as required.

## 9.3 Bottom block

- Grease the load hook traverse and load hook bearing regularly using the lubricator as per the maintenance schedule. The greasing intervals depend on the number of operating hours and the conditions of use and must be executed earlier as specified in the maintenance schedule under extreme conditions if necessary.



### **! WARNING**

#### **Welding on the bottom block**

A welded bottom block can break. The load can fall because of this. This may result in accidents.

- Welding work on hook blocks is prohibited.

## 9.4 Counterweight

- Check the leak tightness of the locking cylinder as per the maintenance schedule. Check the functioning of the lock and cylinder fastening.

## 9.5 Jib\*)

- Grease bearings, bushings and boltings.
- Grease the boltings for attaching the adapter unit to the boom head.

## 9.6 Central lubricating system

For instructions regarding operation, servicing and maintenance as well as specifications of lubricants and lubrication points, please refer to the documents provided by the device manufacturer.

The manufacturer's specifications must be observed.



---

## 9.7 Other lubricating points

Grease joints, pins and all movable components with lubricating oil or grease. The following parts are listed as an example:

- Hinges of the engine servicing lid.
- Hinges of the servicing lid for the air cleaner and batteries.
- Hinges of the working floodlight adjusting device.

Make sure that these parts are running freely and are easy to operate.

All exposed piston rods must be cleaned and coated with "Lube Protection Spray" at regular intervals.

**Notes:**

## 10 Compressed air system

### 10.1 Drain valves in the pressure tanks

- Check properly whether any water condensate is escaping by pulling or pressing on the actuating pins (tilt valve 1).

**No water condensate may escape**

- If it is found that the condensate is escaping, check the functioning of the air dryer (filter insert) and the leak tightness of the compressed air system.

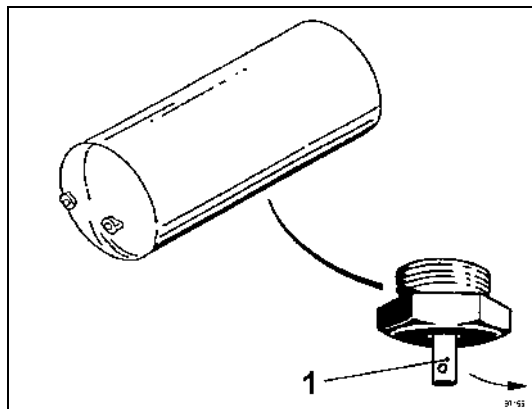

<b>i</b>	A leaky compressed air system affects the operating time of the air compressor and the efficiency of the air drier. Check compressed air system for leakage at regular intervals. Locate and eliminate any leakage immediately.
----------	---

## 10.2 Air dryer

### 10.2.1 Function check

- Activate the drain valves as described in section 11.1.
- If no condensate is escaping, the air dryer desiccating agent cartridge must be replaced only after two years as specified in the maintenance schedule.
- If condensate escapes the drain valves continuously, the air dryer desiccating agent cartridge must be replaced before two years.

### 10.2.2 Replacing the desiccating agent cartridge

- Replace the desiccating agent cartridge only during the switch off phase of the pressure governor.
- Unscrew the desiccating agent cartridge (1).
- Grease the ring seal slightly before screwing in.
- Screw on a new cartridge.
- Check the packing ring, replace it if necessary and tighten the cartridge with approximately 20 Nm.
- Replace the desiccating agent cartridge every two years.

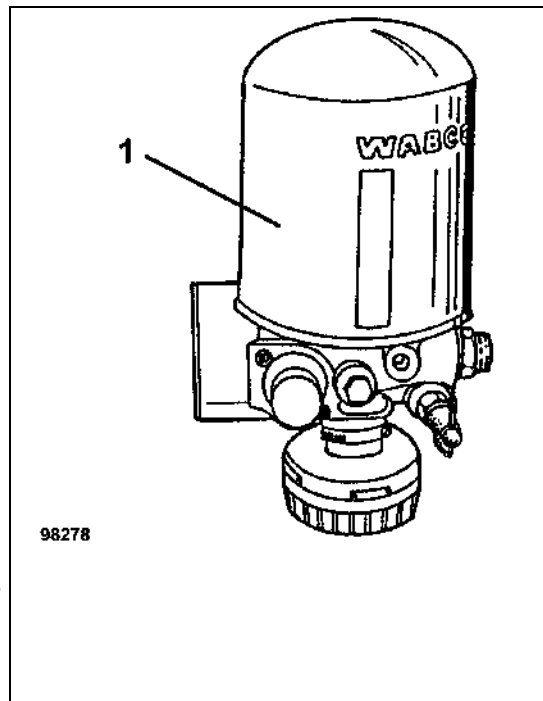

<b>i</b>	Replace desiccant cartridge every 2 years. During the rest of the time, it must be monitored as described under items 7-10.1 and 7-10.2.2.
----------	--

	<b>! WARNING</b>
	<p><b>Risk of accidents due to excess pressure in the compressed air system during maintenance work!</b></p> <p>Excess pressure during maintenance work in the compressed air system may cause personal injury.</p> <p>1) The air drier must be depressurized for maintenance work.</p>

### 10.3 Pressure governor with tire inflation socket (integrated in air drier)

#### 10.3.1 Setting the shut-off pressure of the pressure governor

The pressure governor must be subjected to a visual check and a function check within the scope of statutory regulation of the respective country (in BRD, as per § 29 StVZO (German Road Traffic Regulations)). If defects are identified, dismantle the device and check it from inside or replaced it with another device.

After a longer operation time, the value may deviate from the prescribed switch-off pressure.

- With the engine running, turn the setting screw (1) until the prescribed switch-off pressure is attained.

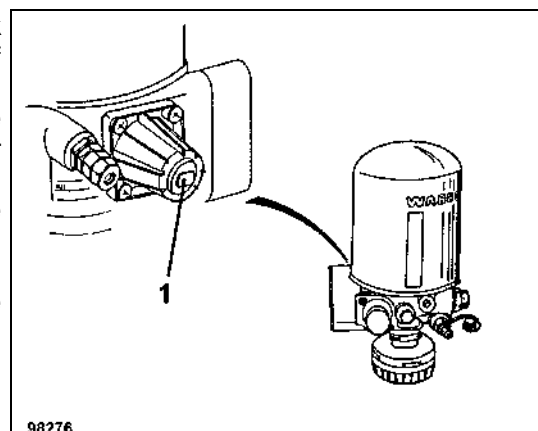

## 10.4 Test connectors for inspection of the compressed air system

The test connectors are mounted to the pressure tank and to the pressure limiting valve.

**i**

After the inspection has been completed, make sure that the test connectors are closed by means of the appropriate protective caps.

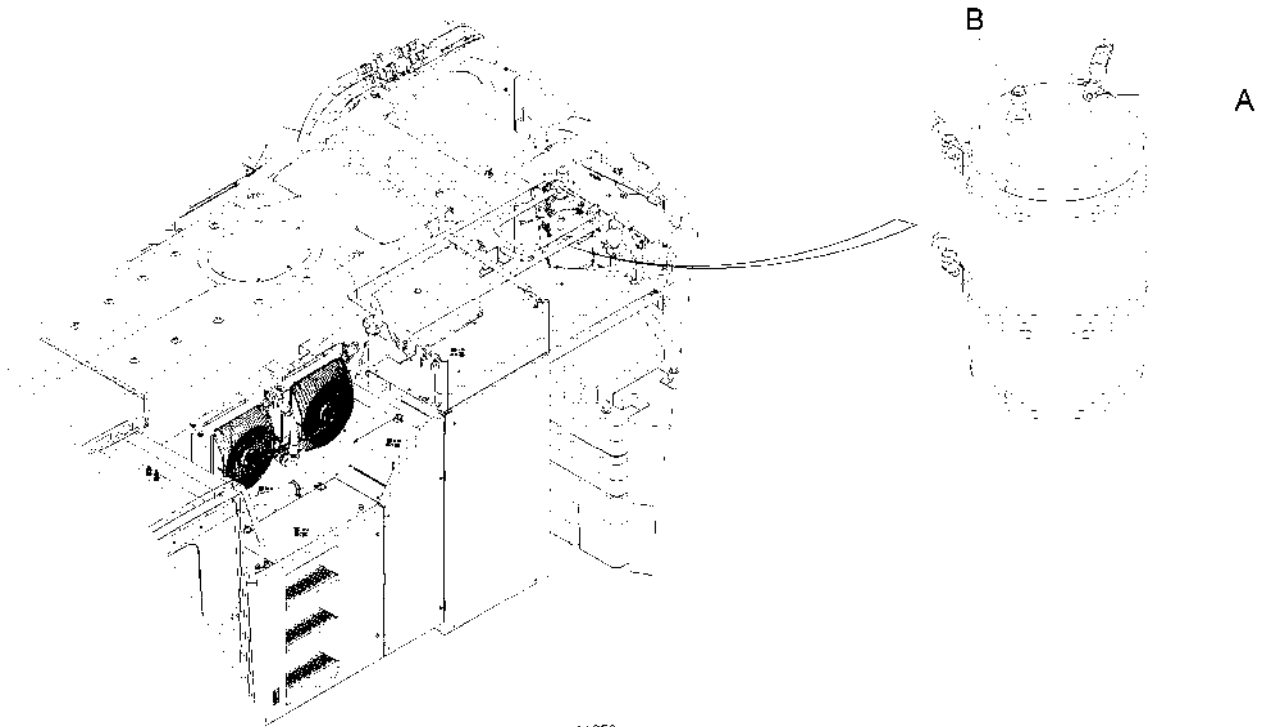

Item	Scope of test and inspection work
A	Service pressure of the compressed air system
B	Supply pressure of the compressed air system

Test and setting values of the compressed air system, refer to item 10.5.

## 10.5 Test and setting values

When replacing valves and pressure switches and in the scope of the regular inspection operations - pursuant to the specific regulations of the country where the machine is to be registered - the following pressure settings must be checked or re-set.

### 10.5.1 Compressed air system

Valve / pressure switch	Inspection	Measuring point	Measured value
<b><u>Pressure governor</u></b>			
<i>Switch-off pressure:</i>	Fill empty compressed air system until switch-off pressure is reached.	Test connector on air drier.	<b>9.8 to 10.2 bar</b>
<i>Switch-on pressure:</i>	Reduce pressure in compressed air system until it is replenished.	Test connector on air drier.	<b>8.5 to 9.5 bar</b>
<b>Pressure limiting valve</b>	Start engine, check pressure at idle	Pressure connector on pressure limiting valve	<b>5.5 – 5.9 bar</b>

Notes:



## 15 Overview of the oil grades and capacities

### (Oil recommendations)

<b>i</b>	The specified capacities are approximate values. The oil level control screws and oil dipsticks or sight glasses are always important for accurate measurements. Only those grades may be used, which have been released in the fuel lists of the unit manufacturer or specified on the identification plates of the units.
----------	---

Maintenance point	Oil Grade			Capacity
<b>Engine</b>	Engine oils as per DC fuel regulations <b>Initial filling with SAE 10W-40</b>			See DC operating manual.
<b>Cooling agent/anti-freezing agent</b>	Cooling agent as per DC operating manual Anti-freezing agent as per DC fuel regulations			Approximately 23 l
<b>Fuel tank</b>	EN 590 diesel			Approximately 220 l
<b>AdBlue tank</b>	AdBlue® *) ISO 22241 / DIN 70070			approx. 8 l
<b>Hydraulic system</b>	Mineral oils as per: DIN 51524-3: HVLP and/or ISO 6743-4: HV  <b>Initial filling with Fuchs Renolin XtremeTemp 46+</b>			Approximately 800 l
<b>Oil tank</b>		Standard: XtremeTemp 46+	Low temperature: XtremeTemp 32+	Approximately 710 l
For	Ambient temperature	- 15 °C to +40 °C	- 25 °C to +25 °C	
	Operating temperature	- 5 °C to +75 °C	- 10 °C to +65 °C	
<b>Steering,</b>	Permissible temperature	- 15 °C to +95 °C	- 25 °C to +80 °C	
<b>Outrigger, Suspension.</b>	<b>Oil recommendations for mineral oils:</b>			
	Oil for initial filling	Fuchs Renolin XtremTemp46+	Fuchs Renolin XtremTemp32+	
	Fuchs	Renolin XtremTemp46	Renolin XtremTemp32	
	Shell	Tellus STX 46	Tellus STX 32	
	<b>Biologically degradable oils on request.</b>			

\*) AdBlue® is a registered trademark of VDA (Association of the Automotive Industry) in Germany





Maintenance point	Oil Grade			Capacity
Swing mechanism gearbox	Hypoid gear oil SAE 90-GL5 Viscosity class as per ISO-VG 220 DIN 51517 <b>Initial filling with ARAL DEGOL BMB 220</b>			Approximately 4.6 l
Slewing brake Compensation tank	Ambient temperature	Mineral oils as per DIN 51524-2	Biodegradable oils as per VDMA 24568	Approximately 0.5 l
	Above +30 °C	HVLP 68	HEES 68	
	from + 5 °C to + 25 °C	HLP 46	HEES 46	
	Below + 5 °C to - 15 °C	HLP 32	HEES 32	
	from - 15 °C to -25 °C	HLP 22	HEES 22	
	Below - 25 °C	HLP 10		
<b>Initial filling with HLP 32</b> <b>( !Do not use any brake fluid! )</b>				
Multi-disc chamber	ATF II D			0.1 l
Hoisting gearbox	Hypoid gear oil SAE 90-GL5 Viscosity class as per ISO-VG 220 DIN 51517 <b>Initial filling with ARAL DEGOL BMB 220</b>			Approximately 3.5 l
Motor coupling	ATF II D			Approximately 1.0 l
Air conditioning system*) Refrigerator oil and cooling agent	Refrigerator oil: ND-oil 8 Cooling agent: R134a			210 cm <sup>3</sup> 1.65 kg





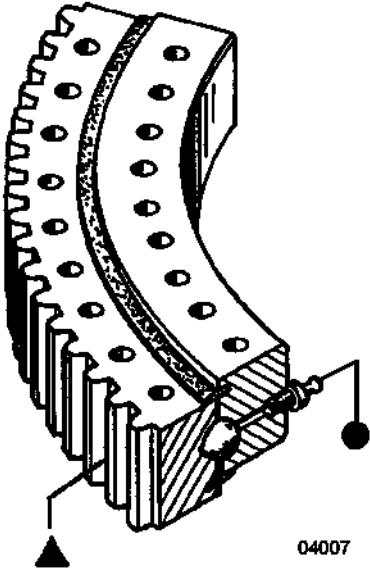

## 16 Grease Overview (Grease Recommendations)





Maintenance point	Grease Grade	Capacity
<b>Gear ring pinion and gear teeth of the ball-bearing slewing ring</b>	Lubrication preserving agent specification BB (DIN 51513) or gear ring bitumen spray	If necessary
<b>Swing mechanism lock pins</b> <b>Grease nipple on: bottom blocks, guide rollers on telescopic booms</b>	Lithium-saponified grease, as per DIN 51825-KP2K-20	If necessary
<b>Hoisting rope</b>	Slushing oil or corrosion protection, grease lubrication or adhesive lubricant or gear wheel spray Lubricity of -25 °C to +120 °C Dropping point 200 °C DIN 51801, consistency class 2 DIN 51818	If necessary
<b>Telescope-sliding pieces, coverings, sliding rails, horn cheeks, guide rollers</b>	Long-term lubricant. We recommend: FAUN-LUB	
	From -40 °C to +125 °C NLGI No. 1 Penetration 310/340 Dropping point +180 °C	From -30 °C to +150 °C NLGI No. 2 Penetration 265/295 Dropping point +185 °C
<b>Telescopic boom</b> <b>Lift cylinder and boom locking</b>	Lithium-saponified grease; dropping point above 170 °C Penetration 2 (as per DIN 51804 or ASTM-D 217) to -20 °C KPL grease 2N (DIN 51502/825) (-20 °C to +140 °C) to -40 °C KTPL grease 2M (DIN 51502/825) (-40 °C to +120 °C)	If necessary
<b>Central lubricating system</b> Grease container	Lithium-saponified grease, as per DIN 51825-KP2K-20	If necessary
<b>Batteries</b>	Battery grease	If necessary
<b>Door locks</b>	Graphite powder	If necessary
<b>Other lubricating points</b>	Lithium-saponified grease, as per DIN 51825-KP2K-20	If necessary

**Notes:**

### 17 Selection table for lubricants and anti-friction agents

<p>Recommended lubricants and anti-friction agents for nipple grease fittings, sliding surfaces and ball-bearing slewing rings as well as gear rings and pinion gears</p>			
<p>Lubrication chart symbols</p>	<p>Table symbols</p>		
		<p>High-quality lithium-saponified grease with penetration 2</p>	
		<p>Special lubricant, adhesive, water-resistant with adequate temperature behaviour</p>	

	●	Rolexa 2	248 K to 403 K
	▲	Engrenage 3	263 K to 393 K
	●	Aralub HL 2	243 K to 393 K
	▲	Aralub LFZ 1	253 K to 403 K
	●	BP Energrease LS 2	243 K to 393 K
	▲	BP Energol WRL	243 K to 353 K
	●	Castrol Spheerol AP 2	253 K to 393 K
	▲	Castrol Grippa 33 S	253 K to 353 K
	●	Chevron Dura-Lith Grease 2	248 K to 398 K
	▲	Chevron Pinion Grease MS	273 K to 398 K
	●	BEACON 2	243 K to 403 K
	▲	SURETT Fluid 4 K	253 K to 333 K

	●	GULF CROWN Grease No. 2	243 K to 393 K
	▲	GULF LUBCOTE No. 2	253 K to 333 K
	●	MOBILUX 2	243 K to 403 K
	▲	MOBILTAC 81	243 K to 393 K
	●	Alvania Grease R 2	243 K to 403 K
	▲	Cardium Fluid C	255 K to 333 K
	●	Glissando FL 20	253 K to 393 K
	▲	Crater 2 X Fluid	253 K to 393 K
	●	VALVOLINE LB-2	253 K to 393 K
	▲	VALVOLINE Dipper Stick	253 K to 493 K
<p>Fritz Manke Technical article Fichtestr. 72 40233 Düsseldorf</p>	▲	Voler Compound 2000 E	243 K to 343 K

**Notes:**

## 8 Annex/Manufacturer's documents

### 8.1 Central lubricating system

#### See also

 Description BEKAtroniX1 [→ 589]

#### 8.1.1 Overview of lubrication points

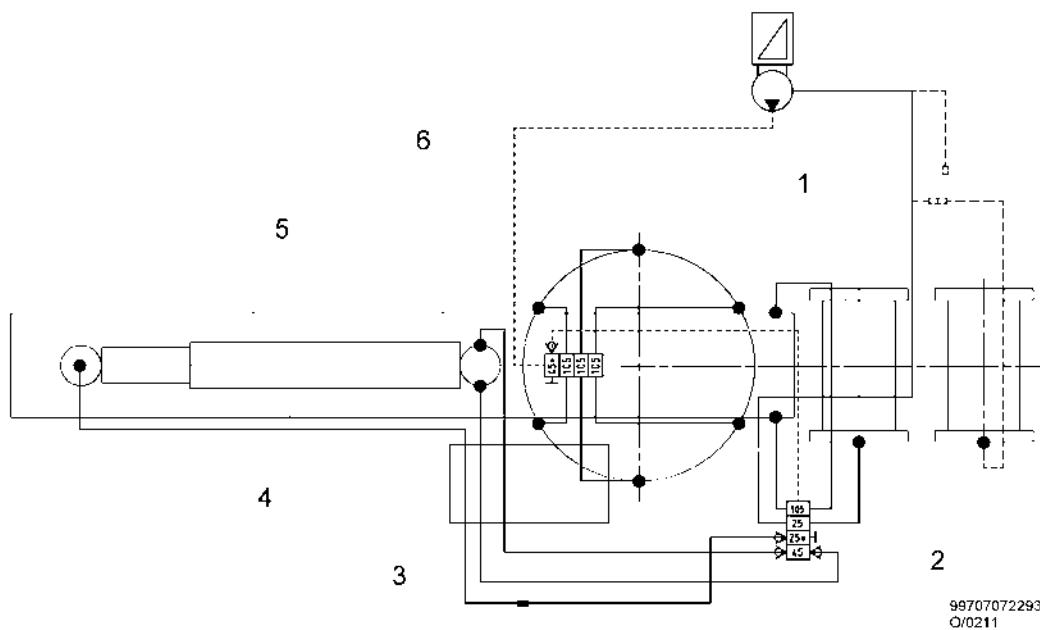

1	Hoisting gear 1	5	Telescopic boom
2	Hoisting gear 2*)	6	Turntable
3	Superstructure cab		Centralised lubrication system lubrication point
4	Derrick cylinder		





## Integrated electronic controller Type BEKA-troniX1

Contents:	Page
General information:	
1. Functional features and installation dimensions	1
2. Function sequence	2
3. Method of operation	3
4. Adjusting the parameters	4
Supplementary functions:	5
5. Excess pressure valve with micro switch	6
6. Grease level controller	7
Summaries:	
7. Signal indicators	8
8. Terminal diagram	9
9. Ordering key for pump	10
10. Retrofitting	11
11. Ordering key for integrated controller	12

### 1. General information:

The BEKA-troniX1 controller generation is a new design of units in an integrated mould for the EP family of pumps.

The controlling device is fitted with a database, that saves the following values:

- Controlling type
- Controller version
- Serial Number
- Manufacturing date
- Method of operation (controlling according to time or revolutions)
- Set values (adjusting ranges)

The following modes can be selected for the controller by means of the diagnostic software BEKA-DiSys:

- A) Time controlling
- B) Revolution controlling

Electronic pump EP-1 with integrated controller BEKA-troniX1:

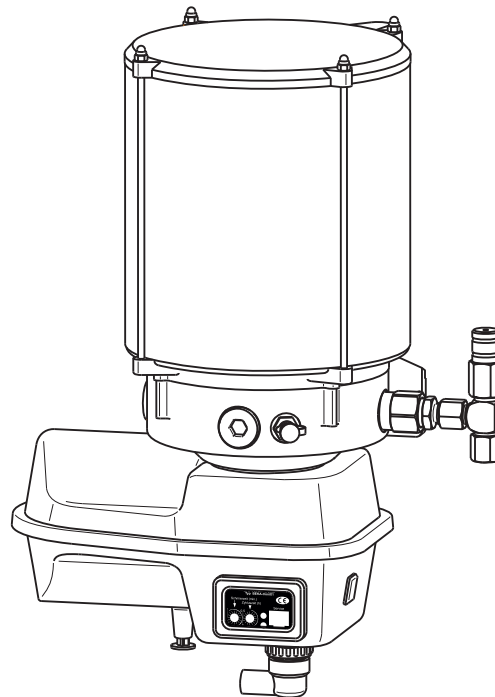

### Installation dimensions:

The electrical pump EP-1 with integrated controller BEKA-troniX1 can be equipped with various reservoir versions. For the installation dimensions of the reservoir versions, see the description EP-1.

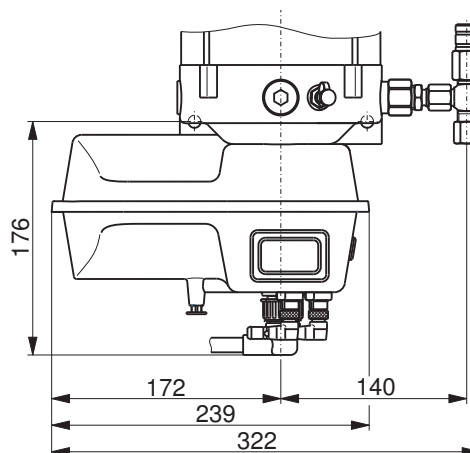

## BEKA-troniX1

### 2. Function sequence

Whatever program is being used, once the ignition has been switched on the green and the red LED or the green and the red signal lamp (optional) lights up on the control panel for 1.5 sec. and shows that the controller is operational (activation control).

Every time the controller is activated for the first time, a lubrication process begins. The green LED in the control half shell is lit during the entire lubrication procedure.

The BEKA-troniX1 integrated electronic controlling device has memory at its disposal. This also serves to keep a record of time elapsed. Should the ignition be switched off during lubrication or operational pauses occur, then the time is stopped and recorded. Once the ignition is switched on again the remaining lubrication or pause time is read from the memory and the sequence will be resumed where it was interrupted.

At any time when the ignition is on, an interim lubrication occurs when the button on the side of the pump motor housing or the illuminated button on the control panel is activated, this serves as a check of functionality. The pump then immediately starts its lubrication cycle, the lubrication or cycle duration recorded up to that point is reset and starts from the beginning.

An interim lubrication can also be triggered via an external button, and the indication of the red and green LEDs can also be displayed by a red and green signal lamp in the driver's cab.

An error can be reset by pressing the interim lubrication button and the pump starts the lubrication process anew.

The lamp on the illuminated button (green) shows the functionality of the controller and the current lubrication sequence.

BEKA-troniX1 integrated electronic controller:

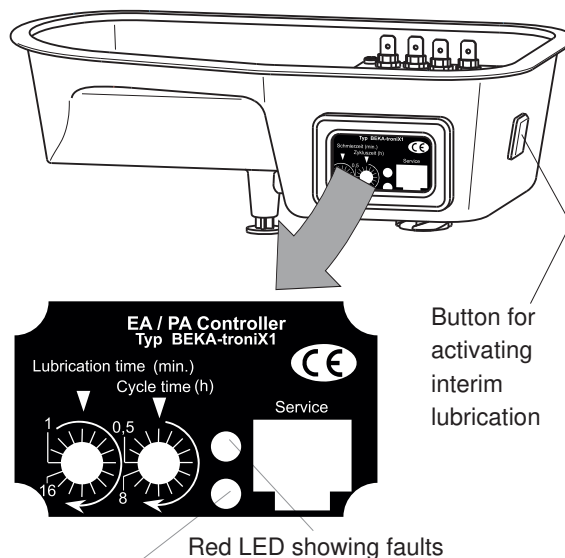

Green LED showing function

#### **Technical data for the controller:**

Operating voltage:	10 to 60 V DC
Maximum current load:	I = 6,0 A
Fuse (not included in device):	F 6,3 A (5x20) medium slow-blow fuse
Signal lamp outlet:	I = 0,4 A
Temperature range:	-35°C to +75°C
Degree of protection:	IP 65

#### **Before the electrical connection:**

**Observe the voltage of the pump motor.**

## BEKA-troniX1

### 3. Method of operation

#### A) Time controller:

When the central lubrication processor is time controlled, the cycle duration and the lubrication time can be adjusted. Cycle duration means the period from the beginning of one lubrication process to the beginning of another lubrication process.

Diagram of cycle sequence:

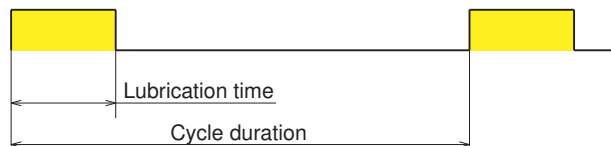

#### B) Revolution controller:

In the case of revolution fluctuations at lower temperatures or high torque, the lubrication duration for the BEKA-troniX1 integrated electronic controller is determined by the number of pump motor revolutions.

The pump motor is connected to the controller via sliding contacts. With every engine revolution a signal is sent to the controller, which counts the incoming signals.

If no signal is received from the pump motor for longer than the adjustable monitoring time (standard 30 sec.) after the lubricating process has begun, the controller will indicate a fault.

The red LED in the pump's lower motor casing or an externally attached signal lamp (optional) start to flash.

**BEKA-troniX1**

**4. Adjusting the parameters**

The cycle time or lubrication time and the number of revolutions can be adjusted by means of rotary code switches in the controller's sight glass.

To adjust the time setting, remove the red frame on the pump's motor housing using a flat screwdriver, loosen the four Phillips screws and remove the transparent protective cover.

The cycle duration or lubrication time can be adjusted by using a flat screwdriver.

If the cover plate is not replaced properly, water may enter the controller and damage it. In this case, the guarantee is no longer valid.

The modes and the adjusting ranges can be changed over by means of the diagnostic software BEKA-DiSys, even on site if the controller has already been operated before.

All adjusting ranges for the lubrication period and all cycle time ranges can be combined at random.

BEKA-troniX1 integrated electronic controller:

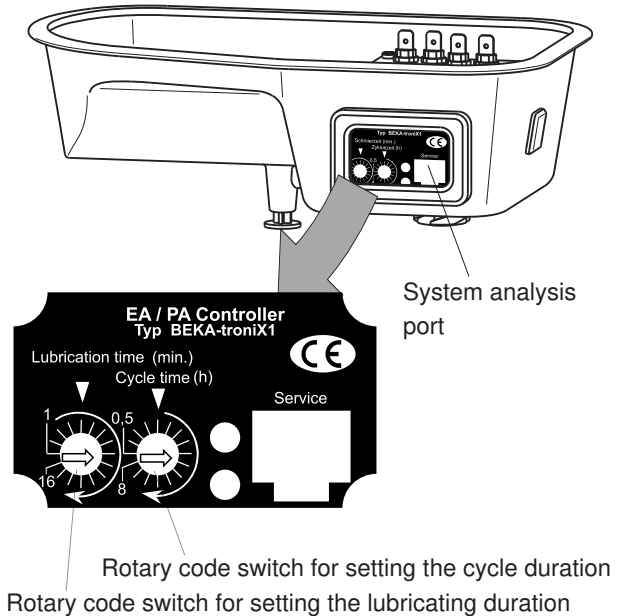

**Adjusting the parameters:**

**Lubrication times:**

- 1 to 16 min. (16 notches every 1 min.)
- 2 to 32 min. (16 notches every 2 min.)
- 2 to 32 sec. (16 notches every 2 sec.)

**Revolutions of pump:**

- 1 to 16 revolutions (16 notches every 1 revolution)
- 10 to 160 revolutions (16 notches every 10 revolutions)
- 170 to 320 revolutions (16 notches every 10 revolutions)

**When changing the activation modes and the adjusting ranges, the label in the controller window must be replaced.**

To this effect, a label kit consisting of 18 different label version is available; these can also be ordered individually afterwards.

Ref.-no. for label kit: 0490000342 German

Ref.-no. for label kit: 0490030343 English

**Cycle duration:**

- 0.5 to 8 h (16 notches every 0.5 h)
- 2 to 32 min. (16 notches every 2 min.)
- 2 to 32 h (16 notches every 2 h)

## BEKA-troniX1 Additional equipment

The integrated electronic controller BEKA-troniX1 can be supplied with two additional functions:

- System excess pressure monitoring
- Grease level monitoring

The additional equipment can be attached to the BEKA-troniX1 controller with any selected program.

In case of a version with additional functions, besides the bayonet connector, two additional four-pole plug-and-socket connectors are located in the lower part of the motor casing.

These additional functions cannot be enabled subsequently in case controllers have been supplied without the as the plug-and-socket connectors at the lower part of the motor casing are missing.

The additional plug-and-socket connectors and the cables of the corresponding switches are marked by colors.

The plug-and-socket connector with the green ring serves to connect the system pressure monitoring system. The plug-and-socket connector with the red ring serves to connect the grease level monitoring system.

Plug-and-socket connectors which are not connected must be closed using a cover.

The additional functions to the controller can be specified in the order.

Cover to close an unused plug-and-socket connector for the supplementary functions of the integrated electronic controller BEKA-troniX1:



Order-no.: 1000913004

Excess pressure valve with micro switch on the pump element and grease level controller, built into electronic pump EP-1:

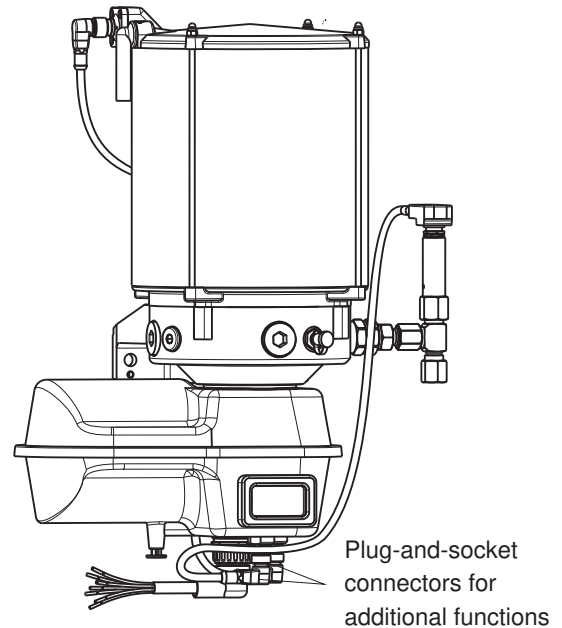

View of the integrated electronic controller BEKA-troniX1 from below:

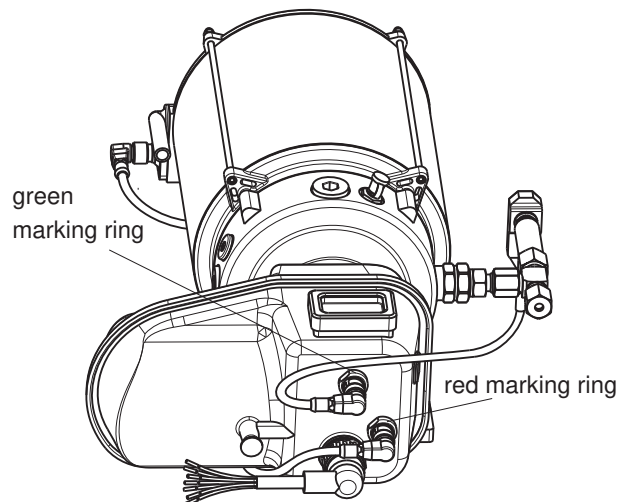

**BEKA-troniX1**

**5. System excess pressure monitoring**

With the BEKA-troniX1 integrated electronic controller, the maximum operating pressure of progressive lubrication system can be monitored.

For this purpose a micro switch has been attached to the excess pressure valve of pump element.

Should a fault occur in the system, e.g. a blockage at the point of lubrication, a pressure of more than 250 bar builds up. A micro switch in the excess pressure valve is activated and sends a signal to the controller. This switches the pump off and the fault is indicated by the flashing red LED and permanent illumination of the green LED or the externally attached signal lamps.

**Technical data for the micro switch:**

Operating voltage:	10 to 60 V DC
Maximum current load:	I = 1,7A
Contact type:	1 changer
Temperature range:	-25°C to +85°C
Degree of protection:	IP 67
Connection:	Cable, length 0.5 m, heat-sealed with 4-pole right-angle plug

Specify in the order whether the micro-switch is to be delivered connected to the controller.

If the micro-switch is to be connected to another control unit, e. g. PLC, an additional cable can be ordered in different lengths (see description EP-1). It can be connected to the cable heat-sealed to the micro-switch.

The pressure monitoring system can be attached to the BEKA-troniX1 controller with any selected program.

Pressure relief valves with micro switches can be retrofitted and connected to the controller if it has been ordered with additional features.

Excess pressure valves with micro-switches required for replacement can be ordered individually:

Pressure relief valve with microswitch for PE-120:  
Order no: 2152 99115

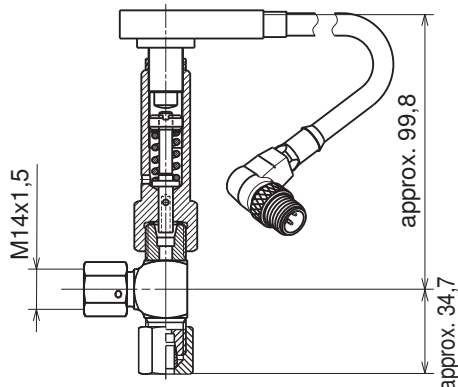

Excess pressure valve with micro switch on the pump element, built into electronic pump EP-1:

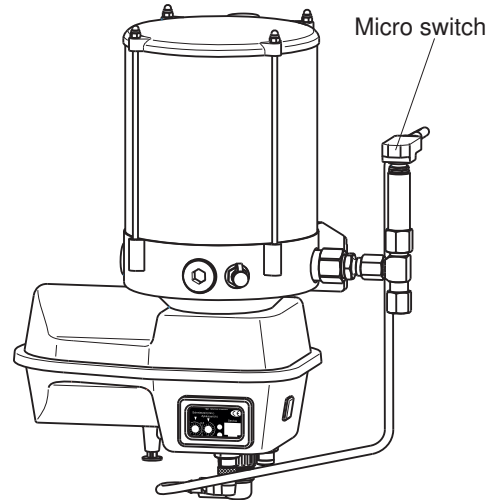

Connection to the controller:

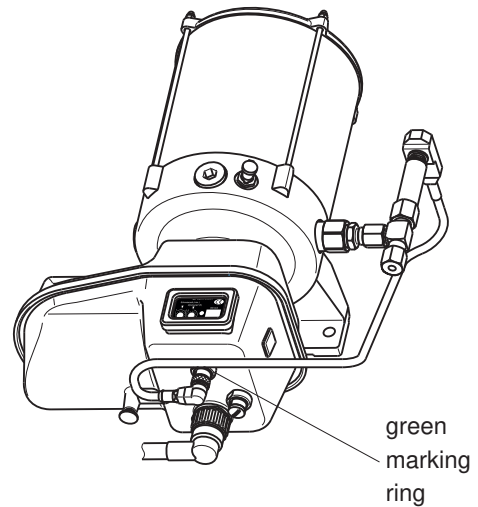

Connection to the controller is effected via the four-pole plug-and-socket connector marked with a green ring, to the pump motor's lower casing; to this effect, the contact plug cover must be removed.

Pressure relief valve with microswitch for PE-120 V:  
Order no: 2152 99116:

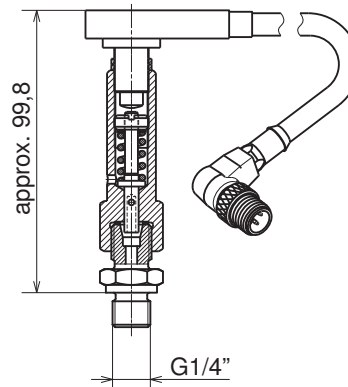



## BEKA-troniX1

### 6. Grease level controller

The integrated electronic controller BEKA-troniX1 facilitates monitoring of the grease level in the storage tank. For purpose a capacitive proximity switch has been built in to the pump's reservoir.

As long as there is enough grease available in the reservoir, the proximity switch sends a signal to the controller. If the grease level sinks below minimum the proximity switch turns the signal off.

If the signal remain off for more than 10 sec. then the controller switches the pump off, so that no air is pumped into the system.

The red LED on the controller display, situated on the pump's motor housing or a built-in red signal lamp, if available, starts to illuminate.

Once the grease has been refilled, the controller restarts itself.

The grease level controller can be ordered connected to the controller; in this case, a connecting cable, length 0,6 m, with a right-angle plug M12x1 for connection to the plug-and-socket connector and a right-angle plug M12x1 for connection to the controller is included in the scope of supplies. The grease level monitoring system is activated.

If the grease level control is to be connected to an external control unit, e. g. PLC, a cable with a socket M12x1 for connection to the contact plug of the grease level controller must be ordered separately (see description EP-1).

The grease level monitoring system can be retrofitted. It can be connected to the control unit if the pump has been ordered with additional functions.

The grease level controller can also be retrofitted. In this case, the function must be activated by means of the software BEKA-DiSys. The function must not be activated if no grease level controller in connected, as this would produce a permanent error.

The cable must also be ordered separately if the grease level controller is to be retrofitted (see drawing on the right).

Connection to the controller is effected via the four-pole plug-and-socket connector marked with a red ring, to the pump motor's lower casing; to this effect, the contact plug cover must be removed.

Grease level controller built in to the 2,5 kg reservoir of an EP-1 central greasing pump:

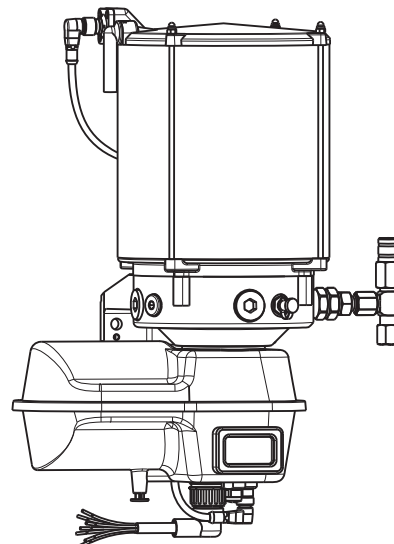

Connection to the controller:

Connection cable  
length 0.6 m  
EDP no.:  
1000912998

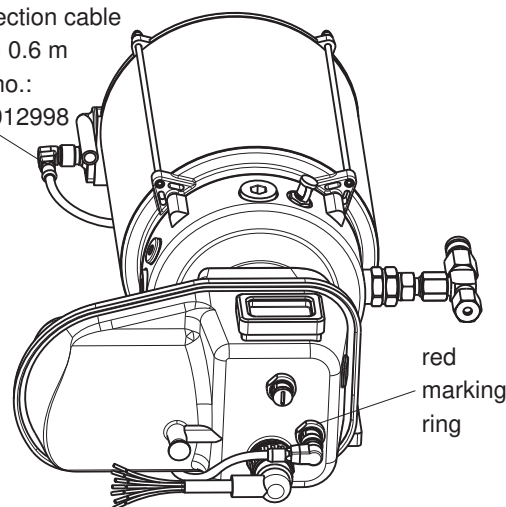

The grease level controller can be attached to the BEKA-troniX1 controller with any selected program.

#### **Technical data for the capacitive proximity switch:**

Operating voltage:	10 to 60 V DC
Switching type:	PNP-turnkey
Maximal current load:	250 mA
Degree of protection:	IP 67
Ambient temperature range:	-25°C to +70°C
Connection:	4-pole, M12x1 pluggable



# BEKA-troniX1

## 7. Summary of Signal Indicators

The pump's functions are indicated via two control LEDs (green/red) in the display on the pump's motor casing, where the red LED always indicates an error in the program sequence.

These control LED functions may be indicated in the driver's cap of the vehicle via built-in signal lamps. These must be ordered additionally.

BEKA-troniX1 integrated electronic controller:

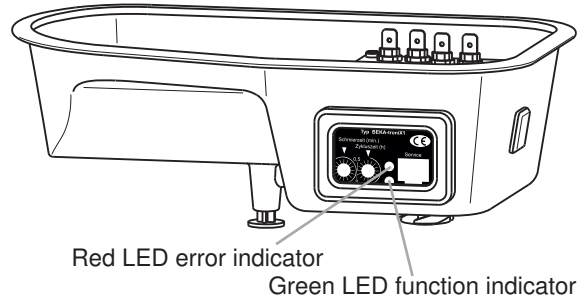

a) Standby

Standby indicator:

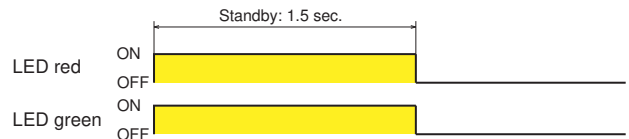

b) Lubrication activated

Lubrication sequence:

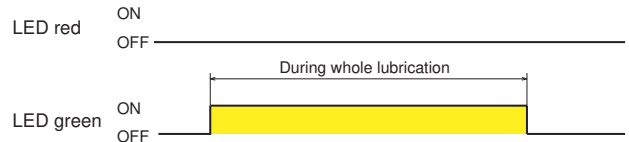

c) Grease level error

Grease level too low:

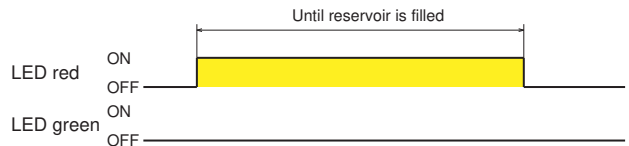

d) Excess pressure error

Excess pressure in main system:

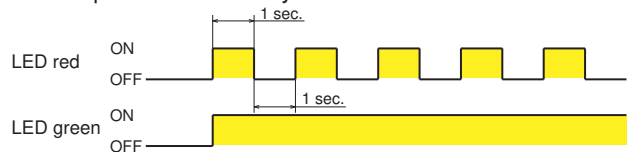

e) Revolution and engine driver error

Revolution error in pump engine:

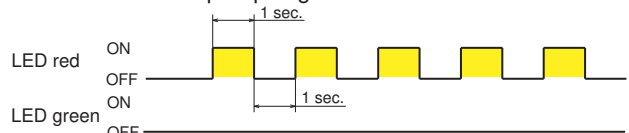

f) Memory error

Memory error:

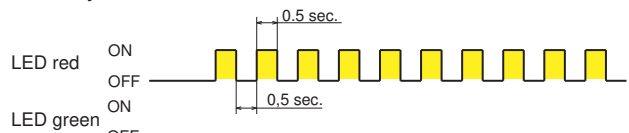

e) Test lubrication (constant lubrication)

Test lubrication:

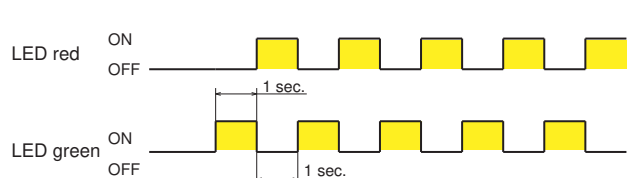

In order to adjust the time controlling to continual lubrication for servicing purposes, the lubrication time must be set to a higher value than the cycle duration.





**BEKA-troniX1**

**9. Ordering key for EP-1 with integrated controller**

**Construction type** **2175.3.1.E.0.1.2.1.000**

Motor voltage	
with bayonet connector	
12V	24V
3	4

Outlet	Pump element	without	PE-60	PE-120	PE-120 V	PE-170
Pos. 1	without micro switch	0	7	1	2	G
	with micro switch	0	A	D	N	H
Pos. 2	without micro switch	0	8	3	4	J
	with micro switch	0	B	E	P	K
Pos. 3	without micro switch	0	9	5	6	L
	with micro switch	0	C	F	A	M
Special variants		ZZZ				

Only one micro switch can be connected to the BEKA-troniX1 controller!

Size of reservoir (kg)	Transparent reservoirs				Steel reservoirs			
	1,9	4	2,5	8	16	2	4	8
without grease level monitoring	1	2	4	8	9	6	7	5
with LM min. plug connection M12x1 in reservoir cover	/	B	A	C	/	/	/	/

Additional equipment	
without connectors for additional equipment	0
Grease level monitoring	1
System excess pressure monitoring	2
Grease level controller and system excess pressure monitoring	3
without connection to the controller (only connectors, not connected, not activated)	4

Parameter	Cycle duration		
	0.5 to 8 h	2 to 32 min.	2 to 32 h
I 1 to 16 min.	1	A	J
II 2 to 32 min.	2	B	K
III 2 to 32 sec.	3	C	L
Pump revolutions			
I 1 to 16	7	G	O
II 10 to 160	8	H	Q
III 170 to 320	9	I	R

Special models 000

The operating modes and setting ranges, respectively, can be subsequently set in the PC by means of the diagnostic software BEKA-DiSys.

Additional functions can be activated or deactivated at any time if the controller was ordered with additional functions, i.e. if the additional plugs are available on the bottom motor housing!

Positions of outlets:

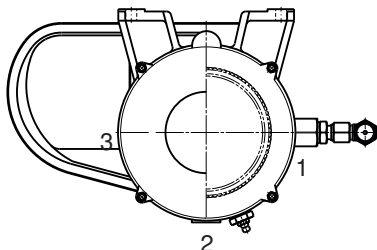

## BEKA-troniX1

### 10. Retrofitting

The integrated controller BEKA-troniX1 can be retrofitted to the electric pump EP-1, i. e. to pumps which have been delivered without controller and to replace existing controllers.

However, retrofitting to pumps without controller is only possible after the year of construction 2004.

Controllers delivered for retrofitting or replacement are not provided with connection cable, as this is normally available. If the controller is to be installed in a pump which has not been equipped with a controller so far, or to be replaced by a controller with another connector, the connecting cable must be ordered separately.

The connecting cables for any supplementary features available must also be ordered separately.

To connect the micro-switch for pressure monitoring, see the description EP-1.

To connect the grease level controller, see description EP-1.

Plug-and-socket connectors which are not used must be closed by using a cover.

Cover to close an unused plug-and-socket connector for the supplementary functions of the integrated electronic controller BEKA-troniX1:

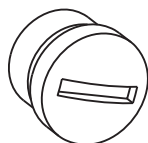

Order-no.: 1000913004

Connection cable, 5 wires, with bayonet connector:

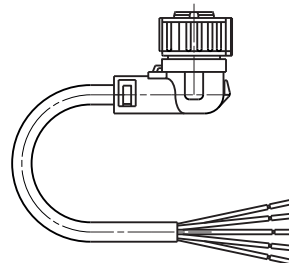

Order-no.: FAZ02499-19

**BEKA-troniX1**

**11. Ordering key for integrated controller BEKA-tronix 1**

<b>Construction type</b>	<b>2175 . 90 . 10 . 0 . A . 000</b>		
Connector version			
with bayonet connector	10		
<b>additional equipment</b>			
without connectors for additional equipment	0		
with grease level monitoring	1		
with system excess pressure monitoring	2		
with grease level monitoring and system excess pressure monitoring	3		
with contact plugs (not activated)	4		
<b>Parameter</b>			
	<b>Cycle duration</b>		
Lubrication time	0.5 to 8 h	2 to 32 min.	2 to 32 h
I	1 to 16 min.	1	A J
II	2 to 32 min.	2	B K
III	2 to 32 sec.	3	C L
<b>Pump revolutions</b>			
I	1 to 16	7	G P
II	10 to 160	8	H Q
III	170 to 320	9	I R
Special models	000		

The operating modes and setting ranges, respectively, can be subsequently set in the PC by means of the diagnostic software BEKA-DiSys!

Additional functions can be activated or deactivated at any time if the controller was ordered with additional functions, i.e. if the additional plugs are available on the bottom motor housing.

## 8.2 Superstructure cab

### See also

 Documents re. crane cab [→ 603]



## Air conditioning system

### Application

The Wölfle **air conditioning system 965212** is a useful extension of our basic heater unit 910154 and is used to condition the superstructure cabin of TADANO FAUN automobile cranes. Thus, please read first of all the enclosed operating instructions for the Wölfle heater unit 910154.

### Technical Details

<b>Air conditioning system cpl.</b>	
Manufacturer	Wölfle GmbH
Model	R134a/ Air
Rated voltage	24 V
Refrigerant	R134a
Refrigerating oil	PAG
<b>Air conditioning expansion kit</b>	
Rated voltage	- -
Cooling capacity (in connection with heater unit 910154)	4.5 kW (± 10%)
<b>Condenser unit (964081)</b>	
Rated voltage	24 V
Max. air throughput	2100 m <sup>3</sup> /h
Thermal output	approx. 13 kW
Fan stages	1
Max. power consumption	11 A
Weight	approx. 9.7 kg
<b>Compressor (359213)</b>	
Model	Seltec TM - 15HD
Rated voltage	24 V
Max. speed	6000 rpm
Delivery	147 cm <sup>3</sup>
Sense of rotation	right-hand or left-hand
Refrigerant	R134a
Oil	ZXL100PG (PAG oil)
- Filling capacity	150 cm <sup>3</sup>
Weight	7 kg
Max. electr. power consumption	48 W
<b>Filter drier (427009)</b>	
Capacity	0.7 l
Filtering effect	up to particle size > 6 µm
Water absorption of dry-type filter cartridge	16 g
Refrigerant	R134a
Weight	1 kg

These data are partially given without being established by measurements and thus should only be considered as approximate values!

## Refrigerating cycle

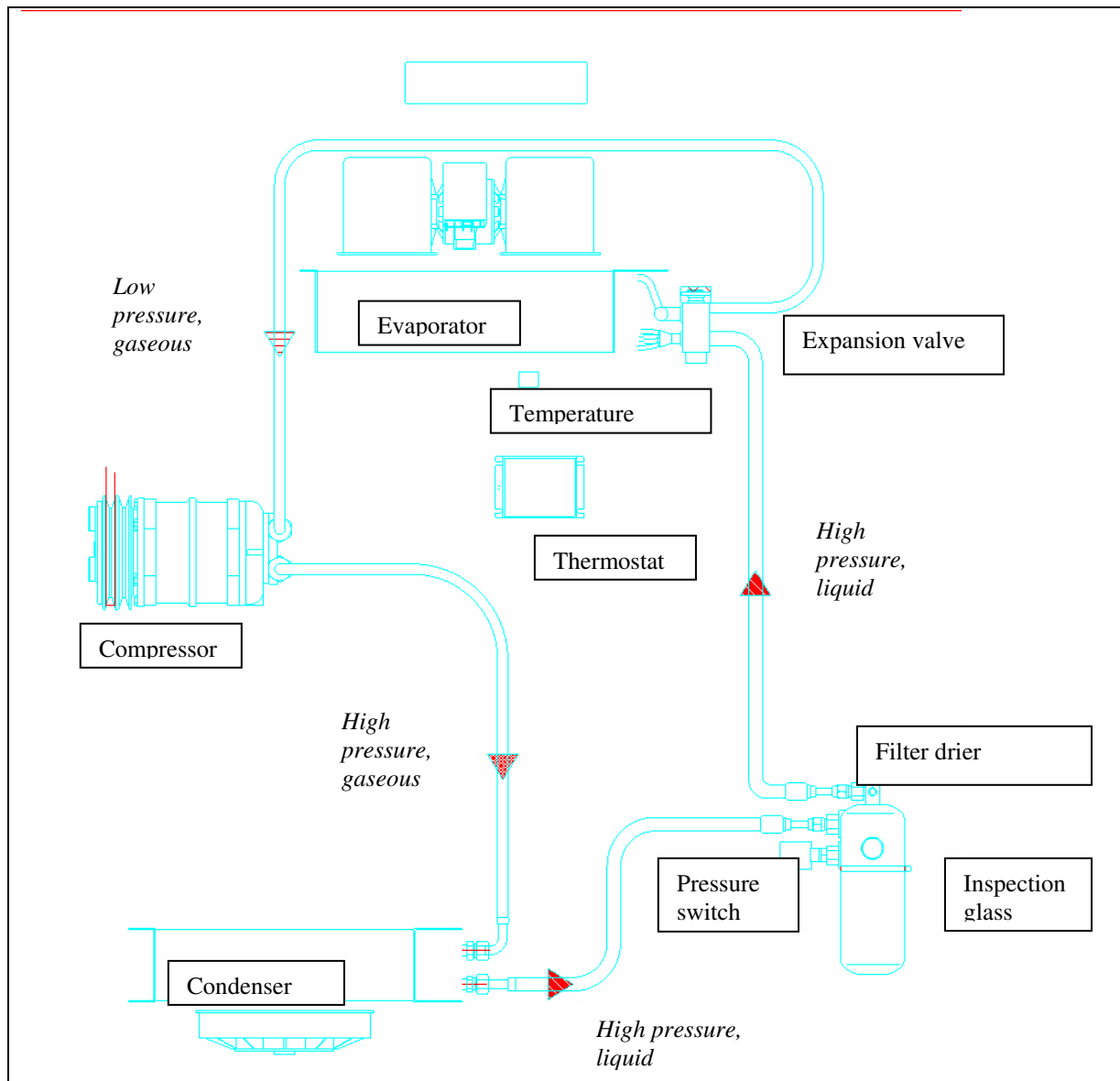

The components of the refrigerating cycle are located as follows:

Evaporator	: Retrofit evaporator on the heater housing
Expansion valve	: on the evaporator
Temperature sensor	: on the heater housing, in the air flow towards the evaporator
Thermostat	: in the electric case next to the MB engine control unit
Compressor	: on the engine or, in case of a hydraulic drive, in the hydraulic drive unit
Filter drier	: on the condenser unit
Pressure switch	: on the filter drier
Inspection glass	: on the filter drier
Condenser unit	: on the ballast



## Operation of the air conditioning system

### Switching ON

For operation of your Wölfle air conditioning system, an additional knob for adjustment of the thermostat with ON/OFF switch for air conditioner operation is located in the control element.

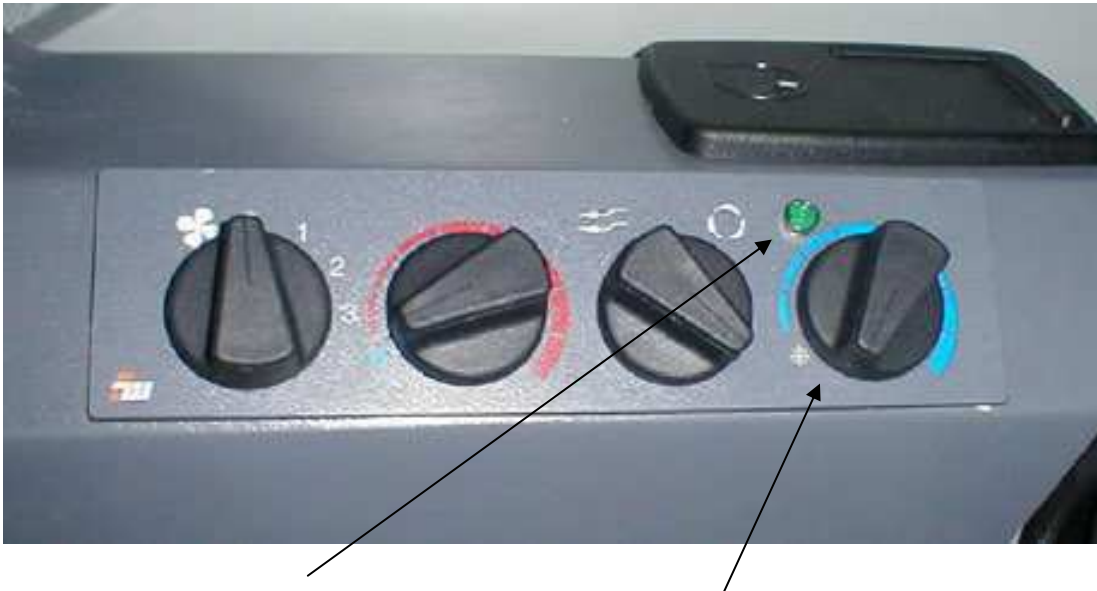

LED indicator "air condition ON"

ON/OFF switch for air conditioning unit with temperature selector function

### Operation

The air conditioning only operates if the fan switch is set at least to stage 1. The LED indicator "air condition ON" is lit. The condenser fan is running.

For maximum cooling effect:

- turn thermostatic switch to the right to its stop;
- turn the temperature switch to the left to its stop ("OFF" position);
- set fan to stage 3;
- set flap to "circulating air"
- close the door and the windows;
- open all air vents.

An individual conditioning comfort range can be adjusted for each crane operator via the air vents which can be varied independently of one another, the thermostat control and the fan control.

You can also operate your air conditioning system in the cold season. Switched on together with your heating, it keeps the air in the driver's cab dry and stops the window panes misting up. To do so, it is sufficient to set the air condition's thermostatic switch to low capacity.

## Switching OFF

To switch off operation of the air conditioning system, turn the thermostatic control to the left to its final stop in position "OFF".

## Maintenance

The air conditioning system must be switched on briefly at least once per month. This operation is required to ensure lubrication of the compressor.

The following maintenance work must be performed at the beginning, in the middle and at the end of a cooling period:

- Check Vee belt tension and fastening of the compressor
- Check refrigerant filling
  - To this effect, the refrigerant must pass the inspection glass of the liquid tank free of bubbles when the engine is running and the air conditioning system is operating at maximum capacity.
- Cleaning the condenser:
  - The discs of the condenser must be cleaned gently without using high pressure, as they would otherwise get bent.

The system should be checked in your workshop every year at the beginning of a refrigerating period.

## Error diagnosis

To this effect, refer also to "Electric circuit diagram, air conditioning system in superstructure 99707770980, page 32"

This list only mentions the most frequent fault hazards. Only specialist staff should be allowed to work on the air conditioner !!!

Malfunction	Cause	Fault detection	Remedy
System's cooling effect insufficient	Insufficient air throughput in the cabin	Check filter	Replace filter
		Leakage in air guide system	Eliminate leakage
		Temperature sensor faulty (evaporator iced)	Replace sensor
	Condenser soiled	Visual inspection	Clean condenser, (do not bend discs)
	Vee belt loosened	Hissing sounds	Check Vee belt tension
	Condenser fan is not running	Visual inspection	Check fuse (F843)
			Check electrical connections
			if necessary, replace fan
	Compressor damage	Abnormal sounds	Replace compressor
		Increased compressor temp.	Replace compressor
		Lubricant has soiled belt pulley	Clean
	Insufficient refrigerant	Bubbles in the inspection glass during air conditioner operation	
	Filter drier soiled	Vessel is sensibly cooler than supply line	Replace component
	Expansion valve faulty	Excessive high and low pressure	Replace component
		Pressure compensation	Replace component
System does not operate	Fuse faulty	F823 / F843	Replace component

	Relay faulty		Replace component
	Thermostat faulty		Replace component
	Pressure switch faulty		Replace component
	Thermostatic switch faulty		Replace component
	No refrigerant		Repair leakage and fill system again

## 1. Application

The Wölfle heater unit 910154 has been developed specifically for heating the superstructure cabins of TADANO FAUN automobile cranes.

Moreover, the unit is used for defrosting the vehicle's window panes.

## 2. Technical Details

Design : Air heater unit with water heat exchanger

Thermal output : (so far, no measured data)

Rated voltage : 24 V

Service voltage : 20....28V

Service overpressure : 1 bar

Blower fan : - 1060 m<sup>3</sup>/h (blowing free)  
: - 3-stage  
: - Long Life Motor

## Heater unit

The heater unit is installed below the seat bracket.

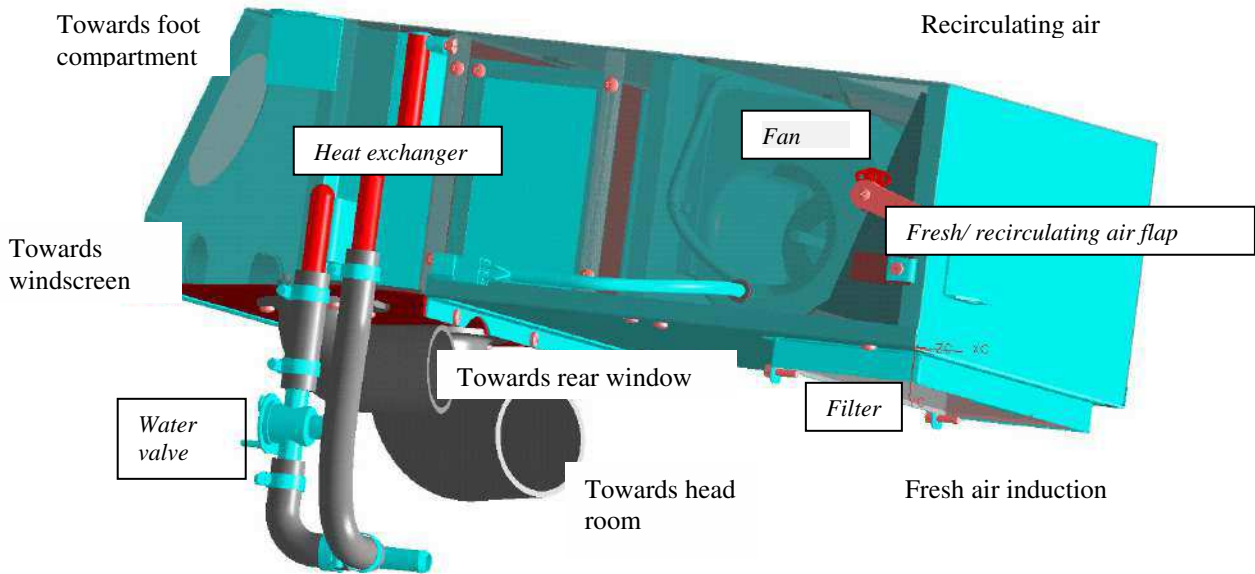

## Control element

The control element is located to the right of the foot compartment. >



3-stage fan switch

Actuation of water valve

Actuation of fresh /recirculating air flap

The water valve and the flap are actuated via Bowden cables.

## Schematic view of air vent distribution:

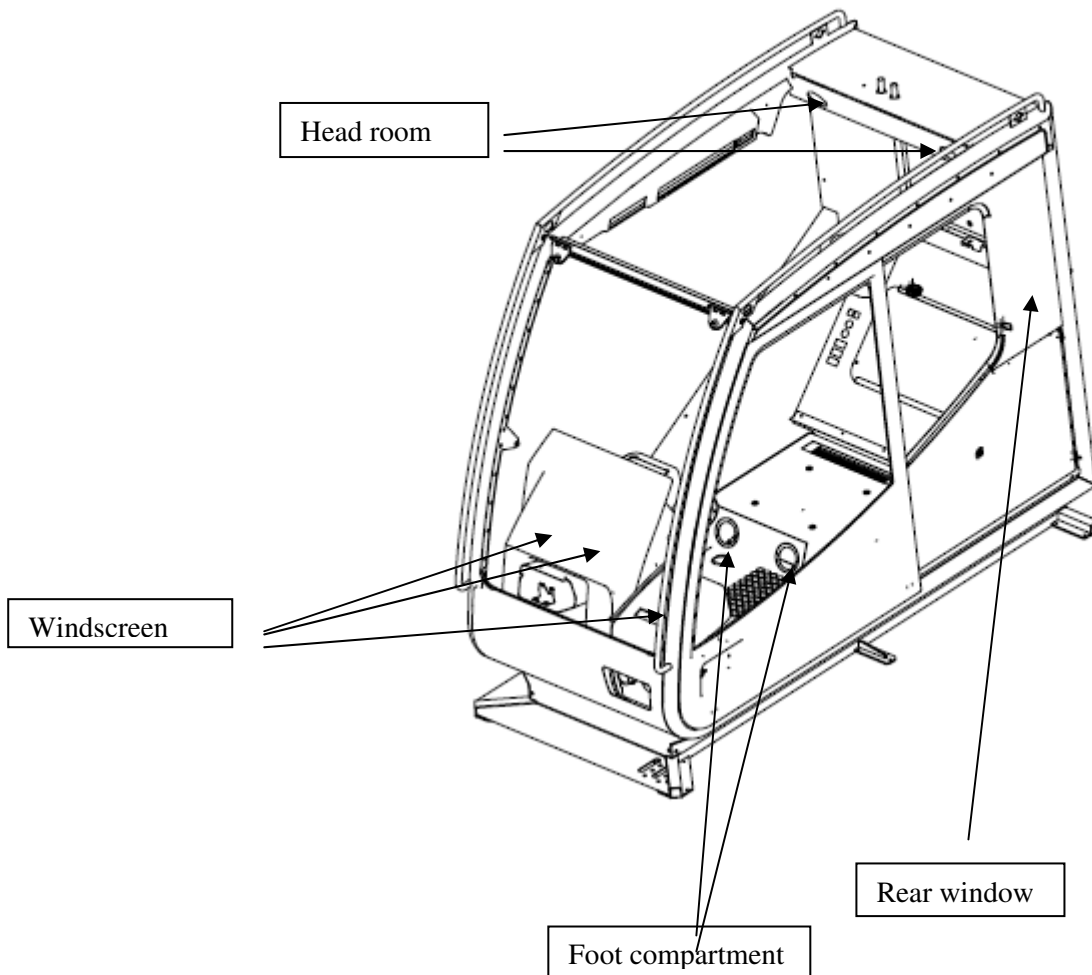

## Operation of the heater unit

### Switching ON

To switch the heater unit ON, turn the temperature controller clockwise. At the same time, turn the fan switch ON to propel the heated air into the cabin.

## Operation

The heater unit can be supplied at choice with fresh air or recirculating air by actuation of the fresh / recirculating air selector switch.

The temperature controller in conjunction with the 3-stage fan switch enables individual variation of the inside cabin temperature.

For maximum heating effect:

- turn temperature switch to the right to its stop;
- set fan to stage 3;
- set flap to "recirculating air";
- close the door and the windows;
- open all air vents.

Defrosting of window panes as above, however:

- only open the air vents concerned (example: for windscreen only the windscreen air vents)

## Switching OFF

The heater unit is switched OFF by turning the temperature controller and the fan switch to "0".

## Ventilation operation

For simple ventilation operation, the temperature controller remains set to "0"; the fan switch is set to the desired position at stage 1, 2 or 3. Open the required air vents.

## Other components

The heater unit has been equipped as standard with a filter, category F7. In case of a considerable reduction of the capacity during fresh air operation, the filter must be replaced.

## Malfunctions

Malfunction	Error location / elimination
Reduced air throughput	Replace filter
Fan inoperative	Check fuse F823
	Check fan switch
	Check fan *

\* This kind of work may only be performed by specialists.



## 8.3 MTU Tier4i-Inducement-Concept

### See also

 [MTU Tier4i-Inducement-Concept \[→ 615\]](#)





## DAIMLER

### Inducement Strategy for Mercedes-Benz Tier 4i Nonroad Engines







The SCR warning and inducement concept is intended to prevent operation of the nonroad equipment in case of no DEF, DEF of insufficient quality and tampering with the elements of the SCR system.

#### 1. Instrument Panel Indicators

Three different indicators must be available on the dashboard for warning of the operator, as listed below. In addition, audible warning is required when LIM indicator is activated (continuous tone). Escalation of audible warning (intermittent tone) will start when LIM indicator is blinking. ECU signal for audible warning corresponds to LIM signal.

Indicator	Indication	Symbol
Diesel Exhaust Fluid (DEF)	Warning & inducement	
Amber Warning Light (AWL)	Failures & tampering	
Torque Limiter Active (LIM)	inducement level solid → early inducement blinking → severe inducement	

#### 2. Operator Warning and Inducement for Low DEF

DEF Level	Indicator	System Reaction/Response
Trigger 1: 14 % ≥ DEF Level Trigger 2: 10 % ≥ DEF Level		<ul style="list-style-type: none"> <li>• DEF solid</li> </ul>
30 min after trigger 2	 	<ul style="list-style-type: none"> <li>• DEF blinking 1Hz</li> <li>• LIM solid</li> <li>• Early inducement 5.1</li> </ul>
60 min after trigger 2	  → 	<ul style="list-style-type: none"> <li>• DEF blinking 1Hz</li> <li>• At torque &gt; 50% : LIM solid</li> <li>• At torque ≤ 50% : LIM blinking 1HZ</li> <li>• Final inducement 5.2</li> </ul>

## DAIMLER

The final inducement time of 2 hours has been selected, since DEF tank has been calculated to be empty no longer than 2 hours after reaching the 10% tank level under worst case operating conditions. The tank level sensor must be calibrated with an off-set of 5 % so that 10 % DEF tank level in reality corresponds to 15 % DEF tank level.



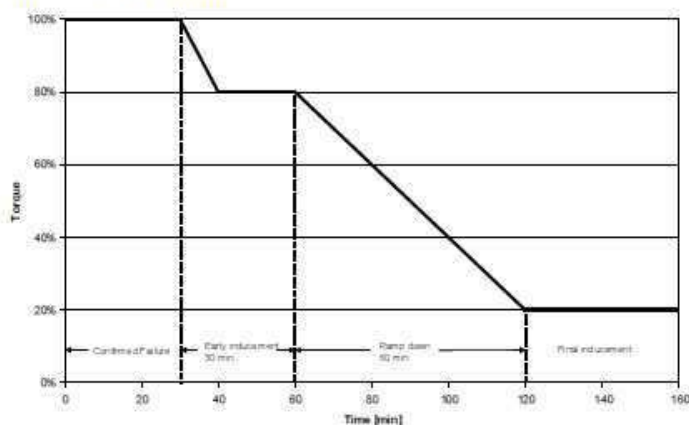



The time sequence of warning and inducement is shown in Figure 1. Total time until final inducement is 120 minutes.



**Figure 1 Low DEF warning and inducement sequence**

### 3. Operator Warning and Inducement for Incorrect DEF Quality

Incorrect DEF quality is detected via the NOx sensor.

DEF Quality	Indicator	System Reaction/Response
Trigger: detection of incorrect quality		<ul style="list-style-type: none"> <li>• DEF solid</li> </ul>
60 min after detection	 	<ul style="list-style-type: none"> <li>• DEF blinking 1Hz</li> <li>• LIM solid</li> <li>• Early inducement 5.1</li> </ul>
180 min after trigger	  → 	<ul style="list-style-type: none"> <li>• DEF blinking 1Hz</li> <li>• At torque &gt; 50%: LIM solid</li> <li>• At torque ≤ 50%: LIM blinking 1 Hz</li> <li>• Final inducement 5.2</li> </ul>

## DAIMLER



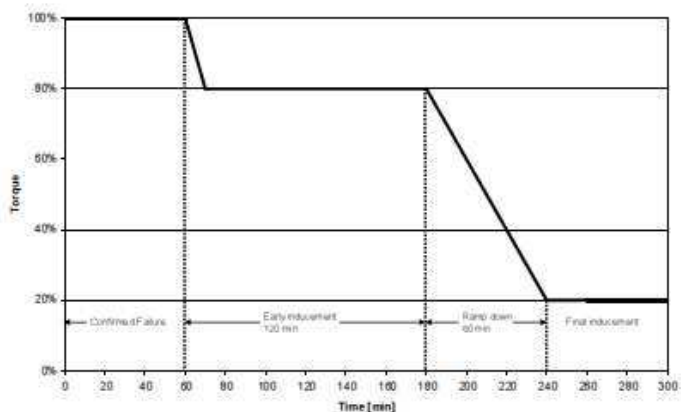





The time sequence of warning and inducement is shown in Figure 2. Total time until final inducement is 240 minutes.



**Figure 2** Incorrect DEF quality and tampering warning and inducement sequence

## DAIMLER

### 4. Operator Warning and Inducement for Tampering

Tampering	Indicator	System Reaction/Response
<b>Trigger: Detection of</b> Disconnect tank level sensor Disconnect DEF dosing line or valve Blocked DEF dosing line or valve Disconnect DEF dosing pump Disconnect SCR wiring harness Disconnect NOx sensor Disconnect DEF temperature sensor Disconnect exhaust temperature sensor	  	<ul style="list-style-type: none"> <li>• DEF solid</li> <li>• AWL solid</li> </ul>
60 min after trigger	    	<ul style="list-style-type: none"> <li>• DEF blinking 1Hz</li> <li>• LIM solid</li> <li>• AWL solid</li> <li>• Early inducement 5.1</li> </ul>
180 min after trigger	   →   	<ul style="list-style-type: none"> <li>• DEF blinking 1Hz</li> <li>• AWL solid</li> <li>• At torque &gt; 50% : LIM solid</li> <li>• At torque ≤ 50% : LIM blinking 1 Hz</li> <li>• Final inducement 5.2</li> </ul>

The time sequence of warning and inducement is identical to section 3 as shown in Figure 2, above. Total time until final inducement is 240 minutes.

### 5. Implementation of the Inducement Strategy

#### 5.1 Early Inducement

Maximum available torque is reduced to 80% of peak torque across the speed range, as shown in Figure 3 within 10 ± 1 minutes.



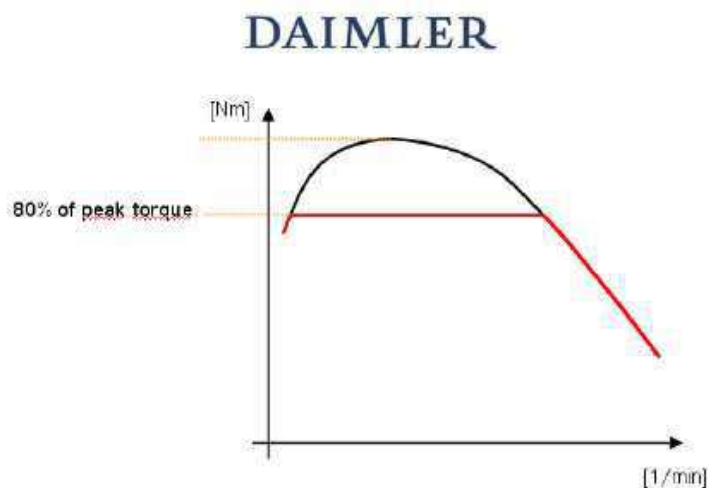

**Figure 3 Engine derate during early inducement**

### 5.2 Final Inducement

The final inducement engine operation is 1000 RPM and 20 % of peak torque, which is slightly above engine idling. Equipment operation will be severely impaired under these conditions.

The step from early inducement to final inducement is done by gradually ramping engine speed and torque down within 60 minutes as follows:

- engine torque is ramped down from 80 % of peak torque by 1 % per minute to 20 % of peak torque
- in parallel, engine speed is ramped down from actual speed (at the start of the ramp) to 1000 RPM

### 5.3 Inducement Override

For emergency cases, an inducement override button is installed that can be activated by the operator. This function is also needed for self-healing of the system as validation phase to detect if the failure has been corrected (e.g. if the correct DEF quality has been re-filled). The button will release full engine power for a maximum of 30 minutes, and can be activated for a maximum of 3 times.

Inducement override is only possible between the start of the inducement sequence and final inducement engine operation. Once the engine reaches final inducement according to section 5.2 (1000 RPM, 20 % torque), the override function will be deactivated. Consequently, the override function will principally not extend the ramp times, as shown in figures 1 and 2. During engine operation with active override, the inducement system will continue to calculate inducement times, engine demand speed and engine demand torque in the background.

After returning from override and without healing the failure, engine speed and torque will be continued with the values corresponding to the demand values without override activation. This also means that the maximum override time of 90 minutes (3 activations) can only be used if activated early during the inducement period. For example, once the engine operates in its final 30 minutes ramp-down, only one override activation is possible. If the failure has not been healed during this override, the engine will directly go to final inducement without the possibility of another override activation.

## DAIMLER

### 5.4 Erasing of Fault Code Memory

An active inducement failure can not be erased by clearing of the fault code memory by a generic scantool. Clearing of active inducement failures is only possible by an authorized pass code via the Daimler/MTU service system, after the failure has been corrected by authorized service staff. One pass code is good for one failure and will be documented incl. the name of service staff who issued the pass code.

### 5.5 Repeated offenses

In case of repeated offenses, the original time triggers and ramps are shortened by a factor, which depends on the number of repeated offenses. If a failure is healed (e.g. a NOx sensor is repaired or reconnected), the inducement will be reset and the normal engine operation will be achieved again. If any inducement related failure listed under sections 2 to 4 occurs within 40 hours of engine operation, a shortened inducement period will be activated as outlined below.

For example, if any failure occurs within 40 hours of correcting the previous failure, the time for triggering the low inducement and the time for triggering the severe inducement (incl. ramp down time) will be divided by a factor of 2. A further re-occurrence of any failure within 40 hours of correcting the second failure will lead to a further reduction of the time for triggering and for ramping down by dividing the original times by a factor of 4.

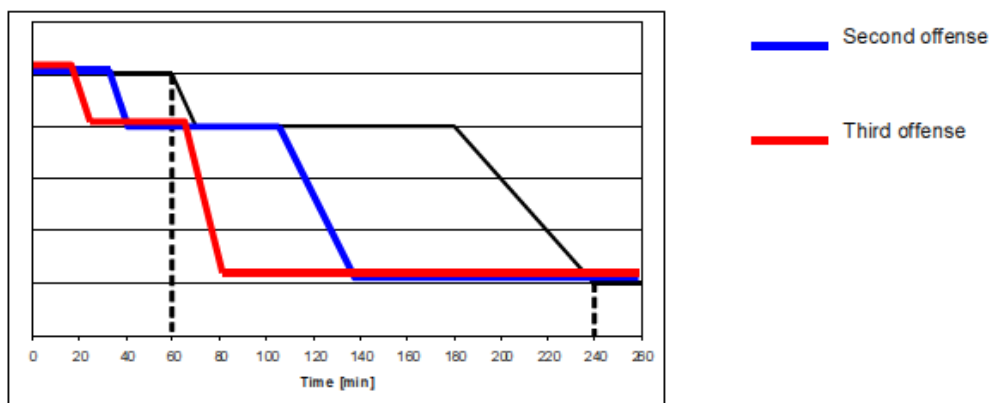



Figure 4 Inducement sequence for repetitive offenses



## 8.4 Dolly traveling operation

### See also

 Dolly traveling operation [→ 623]



# 1 Dolly traveling operation



The legal regulations in force in the country where the crane is to be registered must be observed.

For dolly traveling operation, the boom must be slewed to the rear, deposited on and fastened to the dolly.

During driving operation with a dolly coupled to the rear of the vehicle, the hydraulic circuits for the boom elevation cylinder, the swing mechanism and the swing brake must be locked out, so that the boom can follow the dolly's movements during driving operation. The telescope cylinder must be locked.

The bottom block must be fastened and secured to the dolly.

The vehicle's axle loads must correspond to the legal regulations of the state where the machine is to be registered.

## 1.1 Preparations on the chassis

### Coupling the dolly

**Only dollies which have been homologated for this specific application and approved by the vehicle manufacturer may be used! The legal regulations in force in the country where the crane is to be registered must be observed.**

- The dolly must be coupled to the trailer coupling device (4), if this is specified. Comply with specifications of dolly manufacturer and the legal regulations in force in the country where the crane is to be registered.
- Establish the electrical (2, 3 and 5) and pneumatic (1 and 6) connections.

- 1 Compressed air coupling head „supply“
- 2 Trailer plugbox 24 V DC
- 3 Trailer plugbox 24 V DC
- 4 Trailer coupling device
- 5 Trailer plugbox, ABV
- 6 Compressed air coupling head „brake“

**The trailer plugboxes (2 and 3) ensuring the electrical connection to the trailer are reversal-protected. This also applies to the pneumatic coupling heads (1 and 6).**

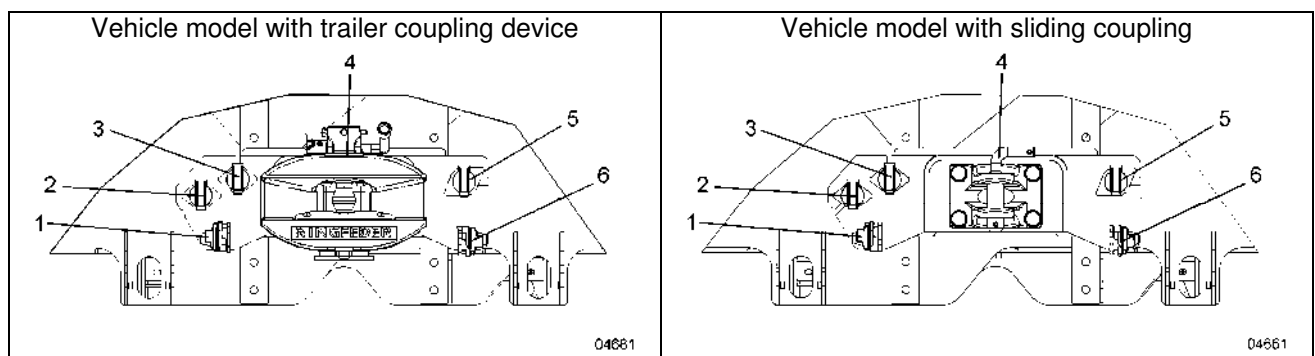

For further steps on the chassis please refer to item 1.3.

## 1.2 Preparations on the superstructure

	<p><b>! DANGER</b></p>
	<p><b>Improper operation of the dolly!</b></p> <ol style="list-style-type: none"> <li>1) The procedures described below must be complied with strictly to ensure safe travelling operation.</li> <li>2) Before actuating the levers to "lock out" position, make sure that the boom is safely deposited on and fastened to the dolly. Failing this, the boom might perform uncontrolled swing movements or even fall. This implies an increased risk of accidents.</li> <li>3) Before driving with a dolly coupled to the vehicle, make sure that the levers are secured in the specified position. To this effect, a padlock, a screw or a similar device may be used. Incorrect lever actuation may result in serious accidents. Make sure that the ball valve are set to "transport" position.</li> <li>4) The levers of the ball valve must be secured in their appropriate control position "normal operation" or "lock out" to prevent their being moved down unintentionally. Padlocks, screws or other appropriate securing devices can be used to secure the levers.</li> </ol>

### 1.2.1 Position of boom

	<p><b>! DANGER</b></p>
	<p><b>Improper position of the boom!</b></p> <ol style="list-style-type: none"> <li>1) The procedures described below must be complied with strictly to ensure safe travelling operation.</li> </ol>

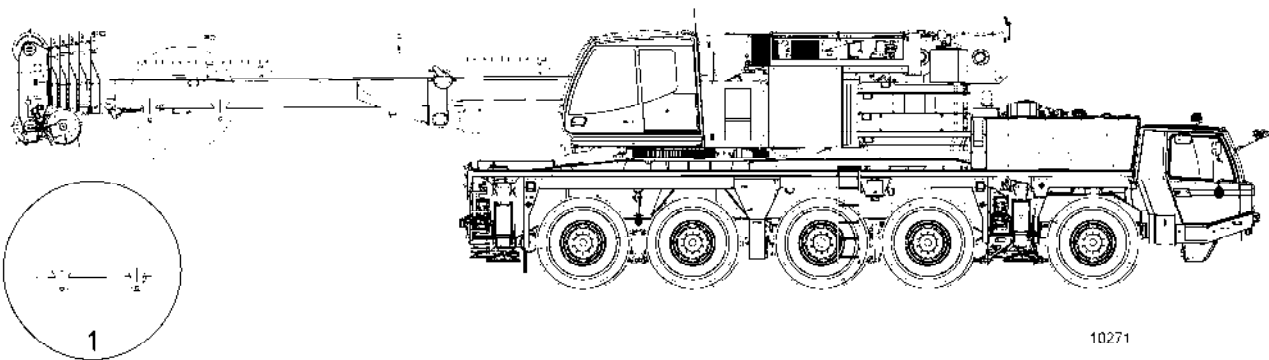

For "dolly mode", the dolly adapter must be fastened to the boom by pins, using the supports (1). Required boom angle position in "dolly mode": the specifications of the dolly manufacturer, or the specific regulations of the country where the machine is to be used, must be complied with.

## Dolly traveling operation

### 1.2.2 Position of ball valves

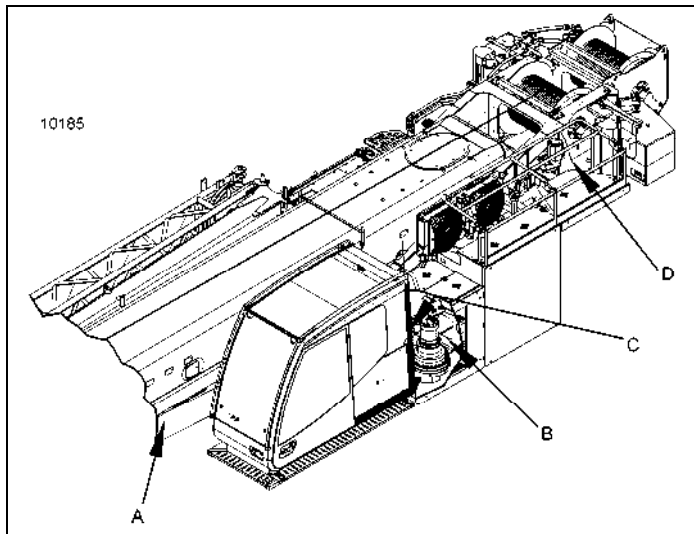

A = Boom elevation cylinder lock-out  
B = Swing brake lock-out  
C = Swing mechanism lock-out  
D = Telescope locking mechanism

### 1.2.3 Changing the superstructure's rig arrangement

	<b>! DANGER</b>
	<b>Improper operation of the dolly!</b> 1) The boom must be deposited safely on the dolly, and secured. If the boom is not deposited safely on the dolly, and secured, it may pivot or fall down. This implies an increased risk of accidents!

	<b>! DANGER</b>
	<b>Risk of accidents!</b> 1) The telescopic boom must be fastened and secured on the dolly according to the dolly manufacturer's instructions. Improper fastening may result in serious accidents.

- Take all the measures described in the operating manual for superstructure operation (refer also to item B-7 in the superstructure).
- Start the superstructure engine.
- Stabilize the vehicle by outriggers.
- Detach the bottom block as described under section 10.1.4 in the superstructure.
- Swing the superstructure to the rear, deposit the boom on the dolly (to this effect, refer also to item 1.2.4).
- If it is necessary to extend the telescopic boom (telescope 1) to a certain extent to enable its being fastened on the dolly, proceed as described under section 9.4.4 in the superstructure.
- Fasten and secure the bottom block to the dolly.
- Lock the superstructure to prevent it from slewing – engage the swing brake (Section 9.4.1, item 2 in the superstructure).
- Fasten boom on dolly.

If the telescopes cannot be locked as described under section 9.4.4 and section 5 in the superstructure (no locking possible in this position), proceed as described below.

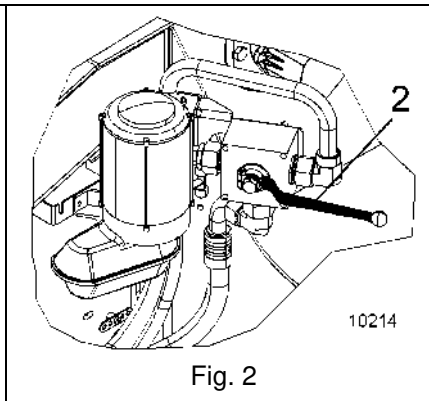
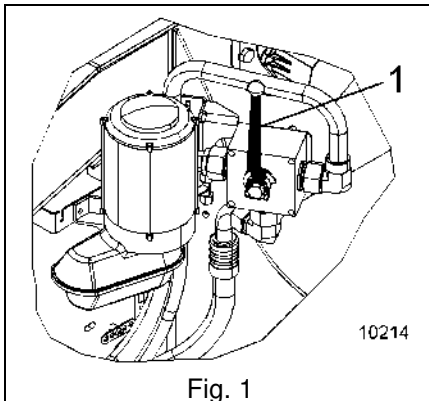

Lock the telescopes

- Remove the ball valve securing padlock.
- Move lever of ball valve (D) from position "normal operation" (1) Fig. 1, to position "telescopic boom locked" (2), Fig. 2.
- Padlock the lever in this position.

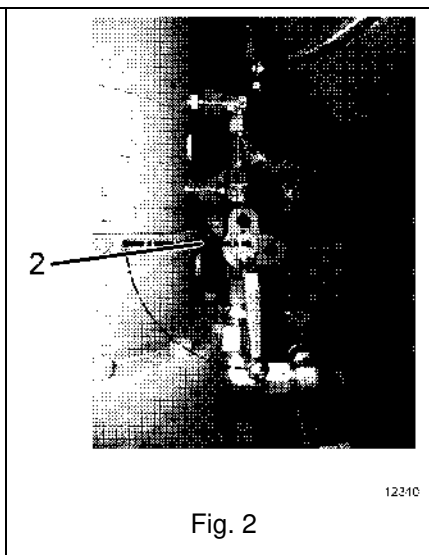
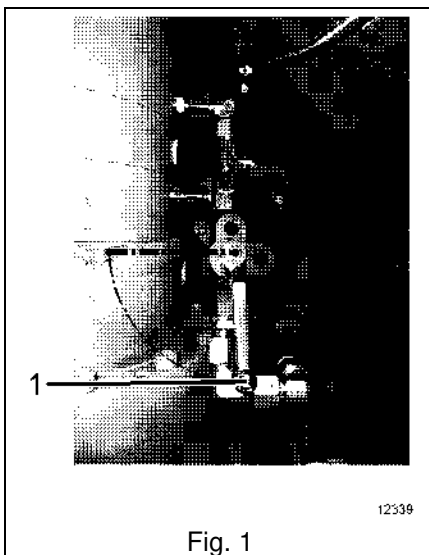

Lock out the swing brake.

- Remove the ball valve securing padlock.
- Move lever of ball valve (B) from position "normal mode" (1) Fig. 1, to "lock out" position (2), Fig. 2.
- Padlock the lever in this position.

- Stop the superstructure engine.

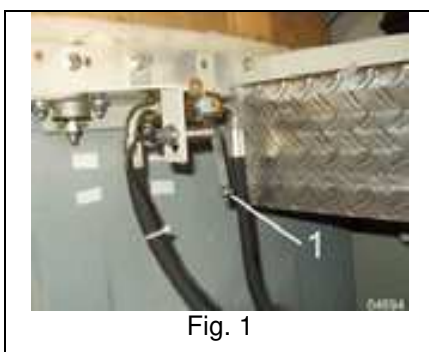

Lock out the swing mechanism.

- Remove the ball valve securing padlock.
- Move lever of ball valve (C) from position "normal operation" (1) Fig. 1, to "lock out" position (2), Fig. 2.
- Padlock the lever in this position.

## Dolly traveling operation

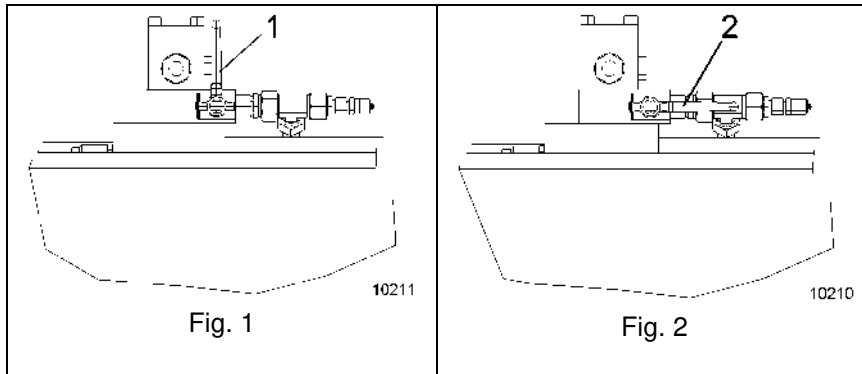

Lock out the boom elevating cylinder.

- Remove the ball valve securing padlock.
- Move lever of ball valve (A) from position "normal operation" (1) Fig. 1, to "lock out" position (2), Fig. 2.
- Padlock the lever in this position.
- Retract the outriggers.

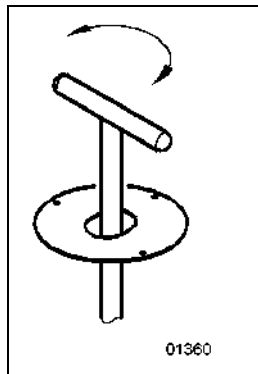

**DANGER**

The mechanical superstructure lock (Section 9.2, item 1 in the superstructure) in the superstructure cabin must not be engaged.

**DANGER**

If the pressure in the swing brake is insufficient - there is a risk of swing brake engaging - the warning buzzer "Dolly malfunction" in the cab of the chassis sounds and the red symbol "Dolly" in the Cockpit-Control-System (item B-4 in the carrier) is lit in the cab of the chassis.

The superstructure has now been changed over for "dolly traveling" operation.

### 1.2.4 Swing brake pressure securing feature

	<b>! DANGER</b>
	<p><b>Risk of accidents!</b></p> <p>1) Should the pressure drop take place within less than one hour, the system is defective. Have the system repaired immediately.</p>

The swing brake's releasing pressure is maintained during "lock out" operation by means of the pressure accumulator. During extended operation, the pressure in the pressure accumulator might be reduced. An alarm is emitted via the warning buzzer "Dolly malfunction" and the red symbol "Dolly" in the Cockpit-Control-System (item B-4 in the carrier), this case, stop the machine immediately and replenish the system as described under item 1.2.3.1.

#### 1.2.4.1 Replenishing the pressure accumulator

If the pressure in the swing brake goes down after an extended period of operation in "lock out" mode, the system must be replenished as described below.

- Stop the vehicle, engage the parking brake.
- Start the engine in the superstructure
- Release swing brake (Section 9.4.1, item 2 in the superstructure).
- With swing brake released, allow the engine in the superstructure to run for approx. 5 minutes at medium speed level.
- Stop the superstructure engine.

### 1.3 Preparations in the driver's cab

#### 1.3.1 Activating dolly operation

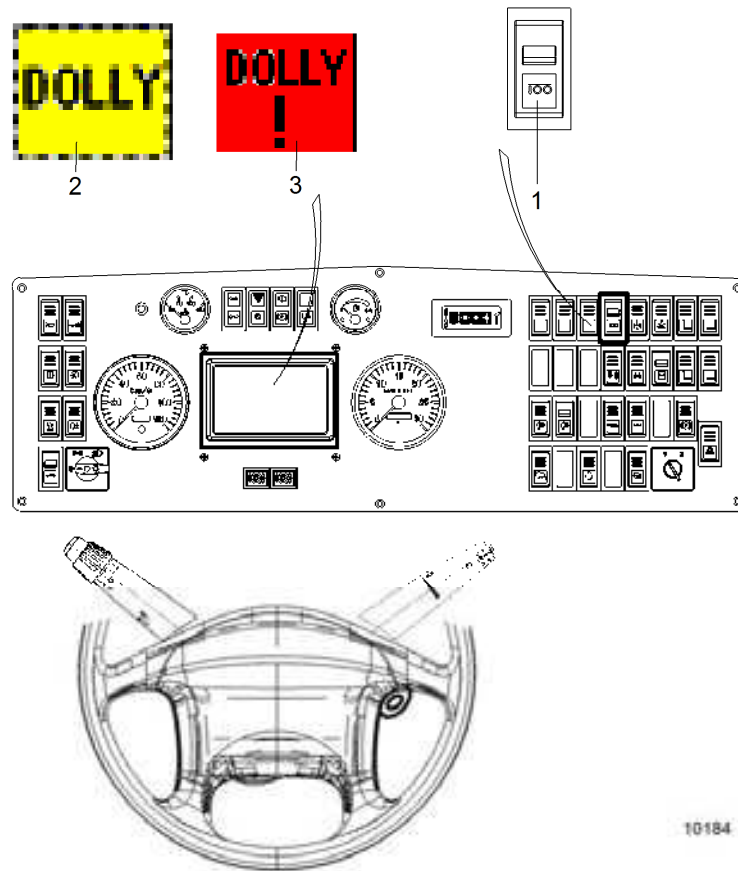

1	Rocker switch " Dolly traveling operation"	3	Icon " Dolly malfunction"
2	Icon " Dolly travelling operation"		

Prerequisite: The rear axles must be set to straight-ahead position.

#### **Switching ON:**

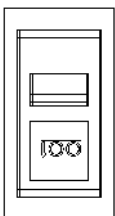

- Unlock the rocker switch (1) "dolly traveling operation" by actuating the lock handle down, and push the rocker switch down. The lock handle automatically returns to its locking position.

The indicator lamp in the switch is lit as long as "dolly travelling operation" is established.

#### **Switching OFF:**

- Actuate the lock handle downwards, and the rocker switch (1) upwards. The swing lock is deactivated.



The yellow symbol appears as long as "dolly travelling operation" is established (see Cockpit Control & Service System, in the carrier).



## Dolly traveling operation

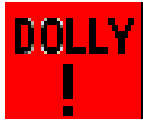

---

The vehicle has now been changed over for "dolly traveling" operation.



The red symbol appears if the pressure in the swing brake is insufficient (see Cockpit Control & Service System, in the carrier) and the warning buzzer "Dolly malfunction" sounds in the cab of the chassis.

### 1.4 Resetting the vehicle to its former rig arrangement

	 <b>DANGER</b>
	<p><b>Crane operation with incorrectly positioned levers!</b> If crane operation is performed with incorrectly positioned levers, this may result in serious accidents.</p> <p>1) Before starting crane operation, make sure that the levers of all ball valve have been moved and locked in position "normal operation".</p>

To reset the vehicle, proceed analogously, reversing the above sequence of operations, as described.

**Memo:**



## 8.5 Fall protection system



### See also

 Fall protection system [→ 633]



# 1 Fall protection system

	 <b>DANGER</b>
	<p><b>Risk of falling when stepping onto the telescopic boom without fall protection system!</b>                  If the fall protection system is not used by persons stepping onto the telescopic boom, there is a risk of them falling. This may result in death or serious injuries.</p> <ol style="list-style-type: none"> <li>1) Use the fall protection system whenever working on the telescopic boom.</li> <li>2) Protect yourself against falling while mounting the slide to/detaching the slide from the rail.</li> </ol>

	 <b>CAUTION</b>
	<p><b>When crane work is performed with the slide mounted, this may result in damage to the slide and the winch rope.</b>                  If the slide remains attached to the rail during crane work, the winch rope and the slide will be damaged.</p> <ol style="list-style-type: none"> <li>1) Before starting crane work, detach and stow the slide.</li> </ol>

The safety belt and the slide belonging to the fall protection system have been provided with the mobile crane.

## Pushing the slide onto the rail

- Attach the safety belt provided.
- Put the slide onto the superstructure platform. Weight of the slide: approx. 23 kg. If necessary, avail yourself of the help of an assistant.
- Move guard railing of superstructure into working position.
- Attach the shackle of the safety belt to an appropriate place on the superstructure.
- Step onto the boom.
- Remove the spring clip (1).
- Remove the pin (2) from the rail.

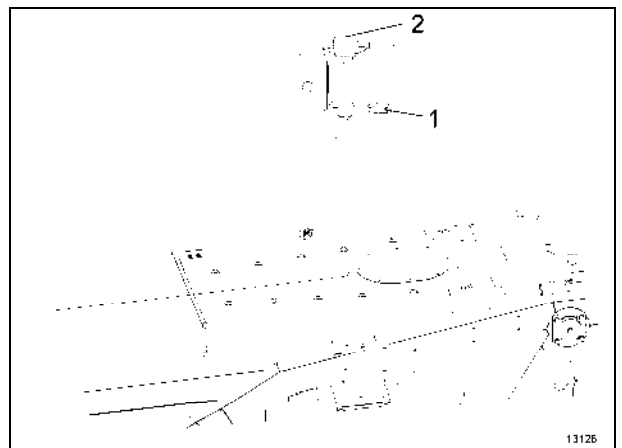

- Raise the slide onto the telescopic boom.
- Release the brake. To this effect, pull the lever (3) and keep it in this position.
- Push the slide onto the rail as shown in the illustration.
- Engage the brake. Release the lever (3).
- Insert pin (2) in rail and lock it using the spring clip (1).
- Release the safety belt from the superstructure.
- Attach both shackles of the safety belt to the eyelets (4) provided on the slide to this effect.

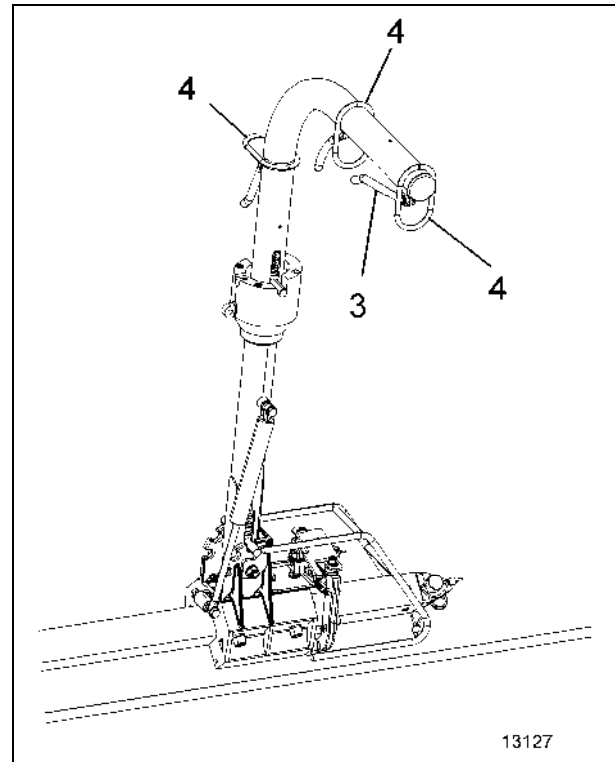

### Pushing, pivoting and turning the slide



#### **!** DANGER

**Risk of accident due to the slide not being secured !**  
If the arm and the upper part of the slide are not locked or if the slide is not braked, the slide may move. This may result in accidents.

- 1) Lock the arm and the upper part of the slide before starting work.
- 2) Brake the slide before starting work.

#### Pushing the slide

- Pull the lever (3) and keep it in this position. The brake is released. The slide can be pushed.
- Release the lever (3). The slide is braked.

#### Pivoting the slide arm

- Pull the lever (5) and keep it in this position. Swing the slide arm by 45° or 90°.
- Release the lever (5). The slide arm is locked.

#### Turning the upper part of the arm

- Pull the lever (6) and keep it in this position. Turn the upper part of the arm by 90° or 180°.
- Release the lever (6). The upper part of the slide is locked.



13128

#### Pulling the slide out of the rail

- Push the slide to the rear end of the rail.
- Release the safety belt from the slide and attach it to an appropriate place on the superstructure.
- Remove the spring clip (1).
- Remove the pin (2).
- Pull the lever (3) and keep it in this position. Pull the slide out of the rail.
- Release the lever (3). Deposit the slide on the superstructure platform.
- Insert pin (2) and lock it using the spring clip (1).
- Step onto the superstructure platform.
- Release the safety belt from the superstructure.
- Fold the guard rail of the superstructure inwards in driving position.

- Stow the slide.
- Take off and stow the safety belt.