

ATF 180G-5

200 TON CAPACITY

ALL TERRAIN CRANE



PRELIMINARY

2 ENGINES

Dimensions (ft, mm) / Dimensiones (ft, mm)

 445/95 R 25 (16.00 R 25)	 525/80 R 25 (20.50 R 25)
---	---

SAE

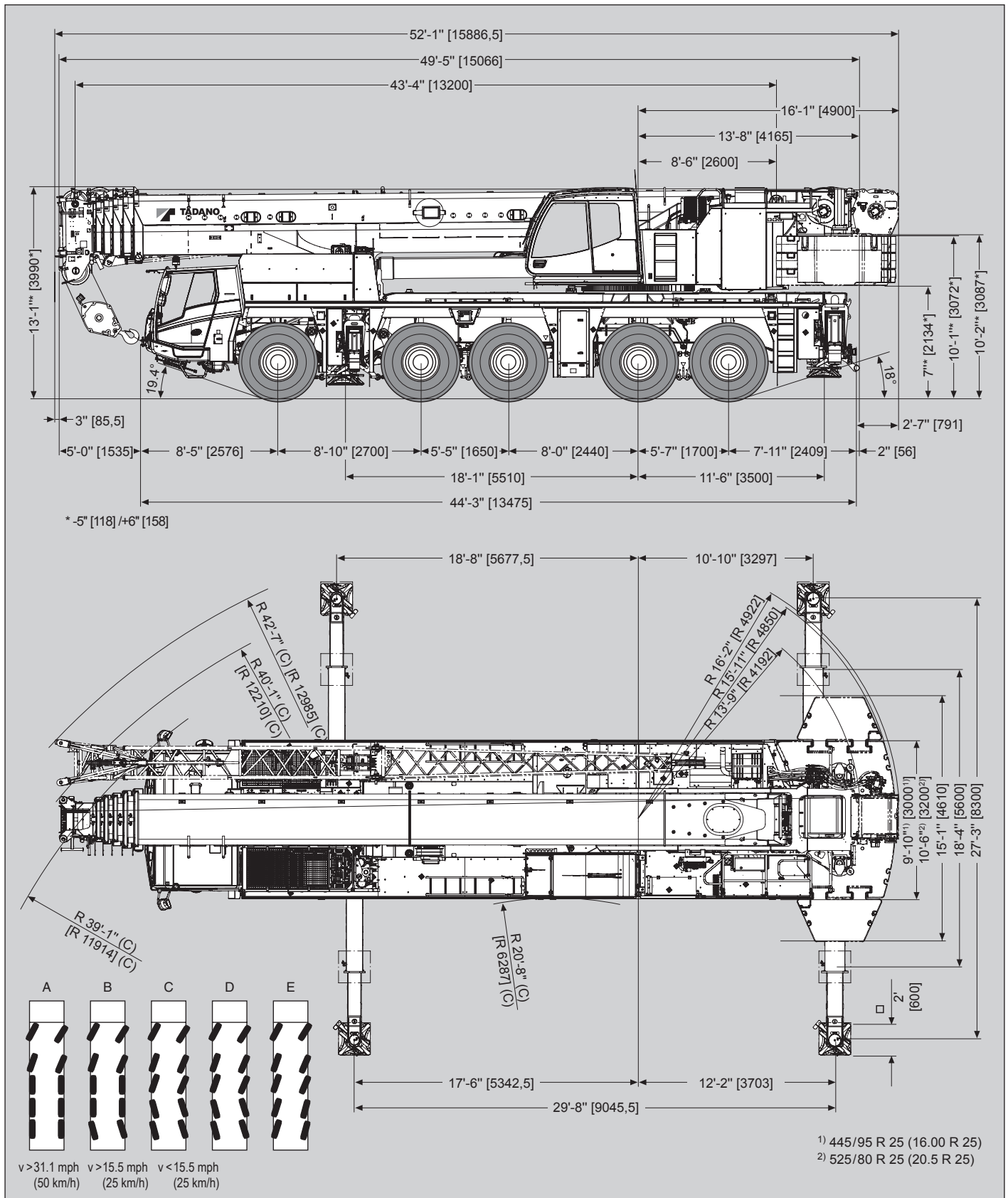





Weights / Working speeds / Pesos / Velocidades de trabajo











 * Rams horn * Gancho doble	Lifting capacity Capacidad de elevación [lbs]	Sheaves Poleas	Part of line Ramales de cable	Weight Peso [lbs]
		238,100 (Type / Typo 176.4 ton)*	7	15
	176,600 (Type / Typo 137.7 ton)*	5	11	2,535.3
	113,800 (Type / Typo 88.2 ton)*	3	7	1,873.9
	113,800 (Type / Typo 88.2 ton)	3	7	1,873.9
	49,200 (Type / Typo 35.3 ton)	1	3	992.0
	16,800 (Type / Typo 11.0 ton)	-	1	661.4

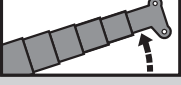

		1	2	3	4	5	6	7	8	9	10	11	12	R1	R2	
445/95 (16.00)		1.9	1.9	2.5	3.7	4.3	5.6	7.5	9.3	12.4	15.5	19.9	25.5	1.9	2.5	63%*
525/80 (20.50) mph		3.7	5.0	6.2	8.1	9.9	13.0	16.8	21.7	28.0	36.0	46.0	52.8	3.7	5.0	48%

* Off road range / * Con transmisión todo terreno

	Infinitely variable Infinitamente variable	Rope (diameter/length) Cable (diámetro/longitud)	Max. single line pull Trio máximo por ramal
	0 - 426.5 ft/min 0 - 130 m/min single line ramal simple	0.83"/ 1,017.1' 21 mm / 310 m	19,109 lbs 85 kN
	0 - 426.5 ft/min 0 - 130 m/min single line ramal simple	0.83"/ 820.2' 21 mm / 250 m	19,109 lbs 85 kN
	Max. permissible line pull may be affected by wire rope strength, which should not exceed 16,800 lbs for main winch and auxiliary winch La fuerza max del cabestrante es dependiente de la normativa en vigor, la cual no permite superar los 75 kN de fuerza.		
	0 - 1.2 rpm		0° + 180°
	-1.5° - +84°	approx. 55 s aproximadamente 55 s	
	43.3 ft - 196.9 ft 13.2 m - 60.0 m	approx. 420 s aproximadamente 420 s	

Lifting heights / Alturas de elevación

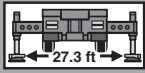
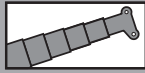



110,230 lbs

lbs x 1,000

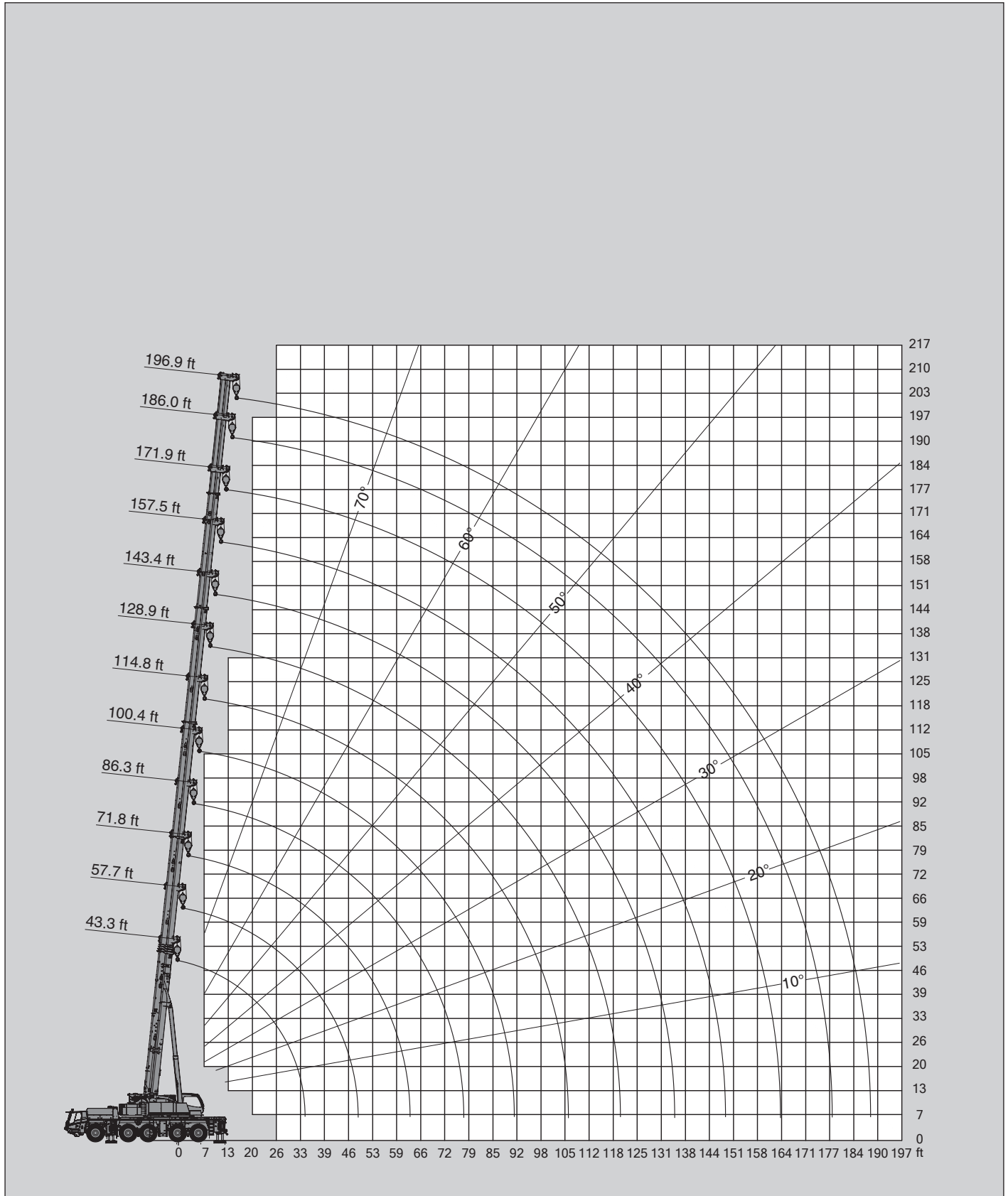
SAE

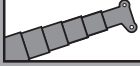
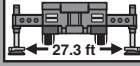

110,230 lbs



lbs x 1,000 SAE

 ft	43.3 ft*	43.3 ft	57.7 ft	71.8 ft	86.3 ft	100.4 ft	114.8 ft	128.9 ft	143.4 ft	157.5 ft	171.9 ft	186.0 ft	196.9 ft
9	400.0**												
10	376.3**	354.5**	264.6**	259.7**	198.4								
12	347.4**	320.1**	264.6**	259.7**	198.4	164.9							
13	322.3**	291.0**	264.6**	259.7**	198.4	164.9							
15	300.7**	266.1**	264.6**	259.7**	198.4	159.8	124.6						
16	275.6**	244.7	244.5	243.2	198.4	153.9	124.6						
20	229.3	209.7	209.4	208.1	198.4	144.0	122.1	95.2	76.1				
23	194.4	182.3	182.1	183.0	182.3	132.1	114.4	95.2	76.1	61.5			
26	168.0	160.7	160.5	161.6	160.5	121.9	107.6	93.0	76.1	61.5	49.2		
30	147.7	143.1	142.6	143.7	142.9	113.1	102.1	88.2	75.0	61.5	49.2	40.3	
33	131.4	127.4	128.1	129.2	128.1	105.4	102.1	83.6	71.6	60.4	49.2	40.3	34.2
36			115.7	116.8	115.7	98.8	98.1	79.1	68.3	58.0	49.2	40.3	34.2
39			105.4	106.5	105.2	92.8	93.9	75.0	67.0	56.2	47.8	40.3	34.2
46			88.0	86.6	88.0	84.4	87.3	67.2	60.6	52.5	45.4	39.0	34.2
53				73.4	73.2	75.4	74.7	60.8	54.9	48.7	42.3	36.8	34.0
59				61.1	65.3	64.4	63.3	55.6	50.0	45.2	39.5	35.3	32.6
66					56.7	54.9	54.5	50.3	45.9	42.1	36.8	33.1	30.9
72					49.2	47.4	47.0	44.5	42.3	38.8	34.6	31.3	29.1
79						42.3	41.0	39.9	38.1	35.9	32.4	29.3	27.6
85						37.5	35.9	37.3	34.0	32.8	30.4	27.8	26.0
92						25.8	31.7	33.3	30.4	29.8	28.9	26.2	24.0
98							28.4	29.8	27.6	26.7	27.1	24.9	22.3
105							25.4	26.7	26.2	24.9	24.5	23.6	20.7
112								24.0	24.9	23.4	22.0	22.3	19.4
118								21.8	22.5	21.4	20.5	20.7	18.1
125									20.5	19.4	19.4	18.7	16.8
131									18.7	17.4	18.3	17.0	15.7
138										15.9	16.8	15.4	14.6
144										14.6	15.2	13.9	13.7
151											14.1	12.6	12.3
158											12.8	11.2	11.2
164												10.4	10.1
171												9.0	9.0
177												8.4	8.2
184													7.5

* Over rear / * Sobre la parte trasera

** With additional lifting equipment / ** Con equipo adicional

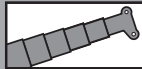
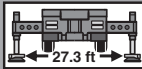
Lifting capacities / Capacidades de elevación

79,366 lbs

lbs x 1,000



SAE

 ft	43.3 ft*	43.3 ft	57.7 ft	71.8 ft	86.3 ft	100.4 ft	114.8 ft	128.9 ft	143.4 ft	157.5 ft	171.9 ft	186.0 ft	196.9 ft
9	400.0**												
10	376.3**	343.7**	264.6**	259.7**	198.4								
12	347.4**	309.3**	264.6**	259.7**	198.4	164.9							
13	322.3**	280.4**	264.6**	259.7**	198.4	164.9							
15	288.6**	256.0**	255.7**	254.4**	198.4	159.8	124.6						
16	259.7**	234.8	234.6	233.2	198.4	153.9	124.6						
20	214.3	200.2	200.0	199.1	198.4	144.0	122.1	95.2	76.1				
23	181.2	173.5	173.3	174.4	173.3	132.1	114.4	95.2	76.1	61.5			
26	156.5	152.3	151.9	153.2	152.1	121.9	107.6	93.0	76.1	61.5	49.2		
30	137.3	135.1	134.7	135.8	132.7	113.1	102.1	88.2	75.0	61.5	49.2	40.3	
33	121.3	121.0	120.4	121.7	115.1	105.4	102.1	83.6	71.6	60.4	49.2	40.3	34.2
36			105.6	106.9	102.3	96.8	98.1	79.1	68.3	58.0	49.2	40.3	34.2
39			91.7	92.8	91.0	92.2	88.2	75.0	67.0	56.2	47.8	40.3	34.2
46			74.1	71.9	76.7	76.9	74.5	67.2	60.6	52.5	45.4	39.0	34.2
53				63.1	63.5	62.6	61.1	58.0	54.9	48.7	42.3	36.8	34.0
59				53.4	53.6	52.0	50.5	48.9	48.3	45.2	39.5	35.3	32.6
66					45.6	44.5	43.0	43.9	41.0	41.4	36.8	33.1	30.9
72					39.5	38.6	37.0	37.9	35.1	35.5	34.4	31.3	29.1
79						33.7	32.2	33.1	32.4	31.7	31.3	29.3	27.6
85						29.5	28.2	29.1	30.4	28.4	27.3	27.3	26.0
92						25.8	25.6	25.6	26.9	24.9	25.6	24.7	24.0
98							24.0	22.7	24.0	22.9	22.9	21.8	21.6
105								22.7	20.7	21.8	21.4	20.5	19.4
112									19.4	20.1	19.2	18.3	17.0
118									18.1	18.3	17.2	16.3	15.0
125										16.5	15.7	14.6	13.2
131										15.0	13.9	13.0	11.7
138											12.6	11.7	10.4
144											11.2	10.4	8.8
151												9.3	7.9
158												8.2	6.6
164													6.0
171													5.1
177													4.2
184													3.5

* Over rear / * Sobre la parte trasera

** With additional lifting equipment / ** Con equipo adicional

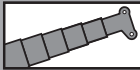
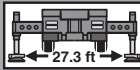
Lifting capacities / Capacidades de elevación



52,910 lbs

lbs x 1,000 SAE

 ft	43.3 ft*	43.3 ft	57.7 ft	71.8 ft	86.3 ft	100.4 ft	114.8 ft	128.9 ft	143.4 ft	157.5 ft	171.9 ft	186.0 ft	196.9 ft
9	400.0**												
10	376.3**	333.1**	264.6**	259.7**	198.4								
12	347.4**	299.2**	264.6**	259.7**	198.4	164.9							
13	306.9**	270.5**	264.6**	259.7**	198.4	164.9							
15	273.1**	246.0**	246.0**	244.5**	198.4	159.8	124.6						
16	244.7**	225.1	225.1	223.5	198.4	153.9	124.6						
20	201.1	191.1	190.9	192.2	190.5	144.0	122.1	95.2	76.1				
23	170.0	164.9	164.7	166.0	153.0	132.1	114.4	95.2	76.1	61.5			
26	146.2	144.2	144.0	136.9	127.0	117.7	107.6	93.0	76.1	61.5	49.2		
30	122.4	122.4	123.0	119.7	107.6	106.5	102.1	88.2	75.0	61.5	49.2	40.3	
33	103.0	103.0	102.1	103.4	98.3	96.1	90.2	83.6	71.6	60.4	49.2	40.3	34.2
36			86.2	87.7	92.2	87.3	79.8	74.7	68.3	58.0	49.2	40.3	34.2
39			79.1	80.2	81.6	78.7	71.2	66.8	64.4	56.2	47.8	40.3	34.2
46			61.1	63.5	63.7	62.8	61.3	56.9	56.0	51.6	45.4	39.0	34.2
53				51.1	51.6	50.7	49.2	49.8	46.5	45.9	42.3	36.8	34.0
59				42.8	42.5	41.7	40.3	41.9	39.2	39.9	37.9	35.3	32.6
66					36.6	34.8	33.5	35.1	35.9	34.6	33.1	33.1	30.6
72					32.4	29.5	30.9	29.8	31.1	30.4	29.5	28.4	28.0
79						25.8	28.4	27.6	27.6	26.9	25.6	24.3	24.3
85						24.0	24.9	24.5	24.0	23.1	22.0	20.7	20.9
92						22.0	21.8	21.4	21.2	20.1	19.2	17.6	17.6
98							19.6	19.0	18.7	17.4	16.5	15.2	15.2
105							17.4	16.8	16.3	15.2	14.3	13.0	13.0
112								14.8	14.3	13.4	12.3	11.2	11.2
118								13.0	12.6	11.7	10.6	9.5	9.5
125									11.2	10.1	9.3	7.9	7.9
131									9.9	9.0	7.9	6.8	6.8
138										7.7	6.8	5.5	5.5
144										6.8	5.7	4.4	4.4
151											4.9	3.7	3.3
158											4.2	2.6	2.6

* Over rear / * Sobre la parte trasera
 ** With additional lifting equipment / ** Con equipo adicional

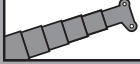
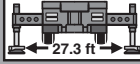
Lifting capacities / Capacidades de elevación

26,455 lbs

lbs x 1,000 SAE

 ft	43.3 ft*	43.3 ft	57.7 ft	71.8 ft	86.3 ft	100.4 ft	114.8 ft	128.9 ft	143.4 ft	157.5 ft	171.9 ft	186.0 ft	196.9 ft
9	400.0**												
10	376.3**	321.9**	264.6**	259.7**	198.4								
12	330.5**	287.9**	264.6**	259.7**	198.4	164.9							
13	289.9**	259.5**	259.5**	259.7**	198.4	164.9							
15	256.0**	235.5**	235.2**	233.9**	198.4	159.8	124.6						
16	228.8**	214.7	214.5	215.6	196.2	153.9	124.6						
20	187.8	181.2	177.9	164.7	149.0	135.6	122.1	95.2	76.1				
23	152.6	152.6	138.2	130.1	119.0	117.7	105.4	95.2	76.1	61.5			
26	118.4	118.4	115.5	108.0	107.6	100.8	93.3	86.4	76.1	61.5	49.2		
30	94.6	94.6	94.4	96.3	91.7	88.2	80.0	74.1	70.5	61.5	49.2	40.3	
33	78.5	78.5	81.8	85.1	82.2	77.8	69.2	67.5	60.8	59.1	49.2	40.3	34.2
36			69.9	72.5	72.3	68.3	60.4	60.0	53.1	51.6	49.2	40.3	34.2
39			60.2	62.6	62.8	60.6	53.1	53.1	50.3	48.5	45.2	40.3	34.2
46			45.4	47.2	48.3	46.5	44.8	45.4	45.0	40.8	39.0	36.4	34.2
53				37.7	39.5	36.6	39.2	38.4	39.0	36.4	34.8	31.7	29.3
59				30.2	32.2	31.7	32.8	32.2	32.0	31.1	29.3	26.7	25.6
66					26.7	27.1	27.3	26.7	26.5	25.6	24.7	22.7	22.0
72					22.5	22.9	22.9	22.5	22.5	21.4	20.3	19.0	18.5
79						19.4	19.8	19.2	19.0	17.9	17.0	15.4	15.4
85						16.5	16.8	16.3	16.1	15.0	14.1	12.6	12.6
92						14.3	14.6	13.9	13.7	12.6	11.7	10.1	10.1
98							12.3	11.9	11.5	10.4	9.5	8.2	8.2
105							10.6	10.1	9.7	8.8	7.7	6.6	6.6
112								8.8	8.2	7.3	6.4	4.9	5.1
118								7.5	7.1	5.7	5.1	3.7	3.7
125									5.7	4.9	4.0		
131									4.9	4.0	2.9		
138										2.9			

* Over rear / * Sobre la parte trasera

** With additional lifting equipment / ** Con equipo adicional

Lifting capacities / Capacidades de elevación





0 lbs

lbs x 1,000 SAE

 ft	43.3 ft*	43.3 ft	57.7 ft	71.8 ft	86.3 ft	100.4 ft	114.8 ft	128.9 ft	143.4 ft	157.5 ft	171.9 ft	186.0 ft	196.9 ft
9	400.0**												
10	361.3**	310.0**	264.6**	259.7**	198.4								
12	311.5**	276.0**	264.6**	259.7**	198.4	164.9							
13	270.7**	247.8**	247.6**	235.7	198.4	164.9							
15	238.8**	223.8**	221.1**	195.8	170.6	149.7	124.6						
16	209.4**	203.3	180.3	163.1	144.0	127.9	120.4						
20	146.8	146.4	129.9	124.1	119.7	109.6	99.4	88.8	76.1				
23	115.3	115.3	107.4	102.3	95.0	87.1	78.5	73.2	66.1	61.5			
26	85.8	85.8	89.7	85.5	78.7	70.8	63.9	62.8	55.8	52.0	49.2		
30	67.0	64.6	71.0	71.0	66.4	61.3	57.1	56.0	51.6	47.2	43.2	40.3	
33	54.2	50.9	56.2	58.9	59.7	52.7	52.0	48.9	46.5	43.2	40.1	36.8	34.2
36			46.1	49.2	51.4	47.8	47.6	43.9	40.6	37.7	35.1	32.0	31.1
39			38.4	41.0	43.4	43.9	42.5	39.0	35.7	33.3	30.9	28.0	27.3
46			27.8	30.2	32.4	32.8	33.1	32.2	30.6	28.4	26.5	23.1	22.9
53				22.9	25.1	25.6	25.8	25.1	24.9	23.1	21.4	18.7	18.5
59				17.6	19.6	20.1	20.5	19.8	19.6	18.7	17.0	15.0	14.6
66					15.4	16.1	16.5	15.9	15.4	14.6	13.4	11.7	11.5
72					12.3	12.6	13.0	12.6	12.3	11.2	10.1	8.8	9.0
79						10.1	10.6	9.9	9.7	8.8	7.7	6.4	6.4
85						8.2	8.6	7.9	7.5	6.6	5.5	4.4	4.4
92						6.8	6.8	6.4	5.7	4.9	4.0		
98							5.3	4.9	4.4	3.3			
105							4.4	3.7	3.1				

* Over rear / * Sobre la parte trasera

** With additional lifting equipment / ** Con equipo adicional

Lifting heights / Alturas de elevación





110,230 lbs
lbs x 1,000
SAE

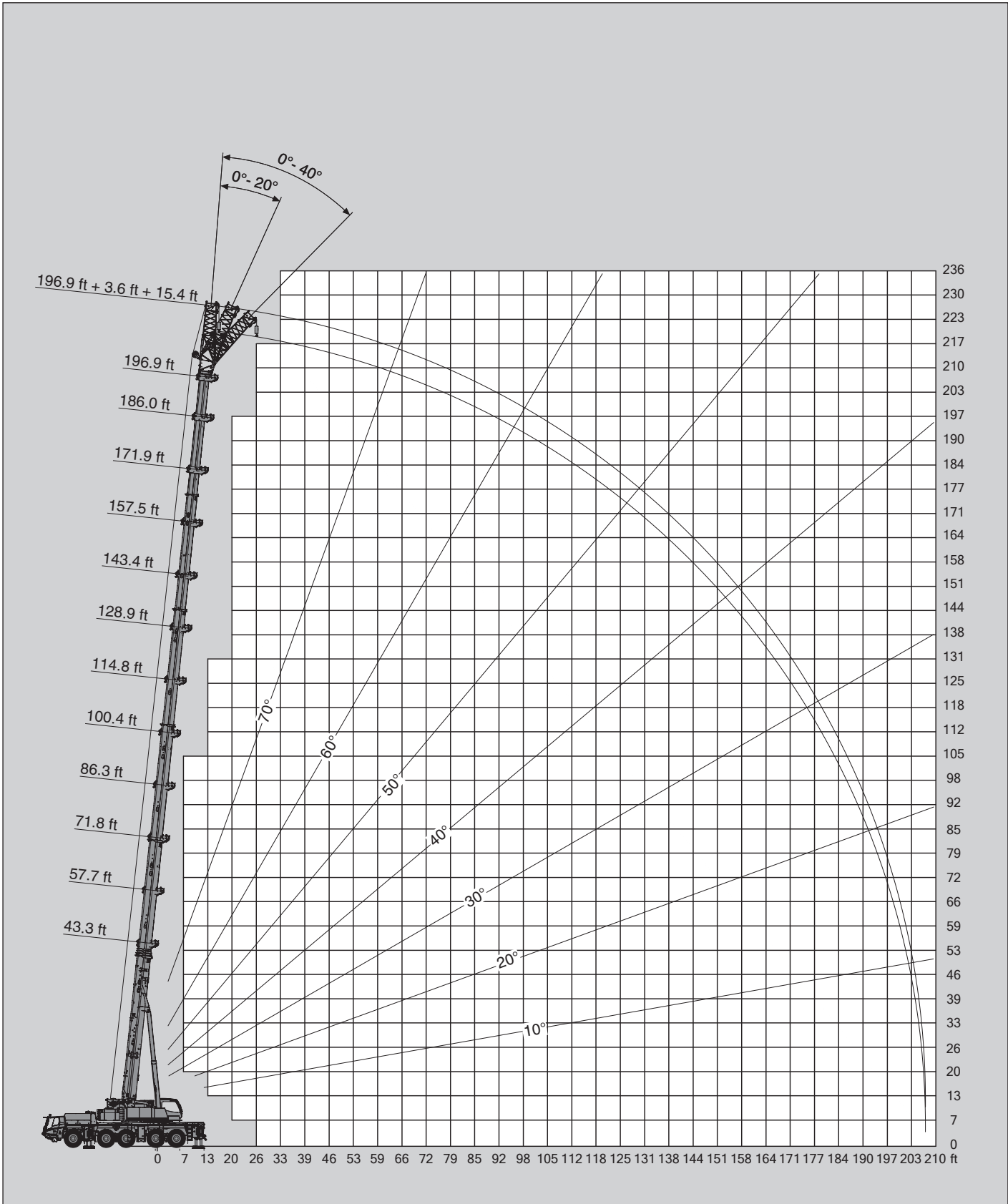

110,230 lbs lbs x 1,000 **SAE**

ft	43.3 ft + 3.6 ft + 15.4 ft			86.3 ft + 3.6 ft + 15.4 ft			100.4 ft + 17.7 ft			114.8 ft + 3.6 ft + 15.4 ft		
	0°	20°	40°	0°	20°	40°	0°	20°	40°	0°	20°	40°
10	89.3											
12	84.3	59.8		84.0								
13	79.9	57.7		84.0								
15	75.8	55.6	45.7	83.2			78.3					
16	72.3	53.8	44.7	80.9	58.0		76.1					
20	69.9	52.0	43.2	78.3	56.0		73.6	57.1		67.0		
23	64.4	50.6	42.3	74.6	52.9	43.7	71.2	55.6		67.0	56.4	
26	59.8	47.9	41.2	70.2	50.5	43.2	67.5	53.4	43.2	67.0	54.7	
30	55.9	45.7	40.3	66.3	49.4	42.5	64.2	51.4	42.5	67.0	52.9	42.3
33	51.8	43.8	39.5	63.0	48.1	41.7	62.6	49.2	41.7	66.8	50.7	41.2
36	49.4	42.1	39.0	59.4	46.1	41.2	59.7	47.4	40.8	63.3	48.5	40.3
39	45.9	40.6	38.6	56.3	44.5	40.8	57.3	46.1	40.1	60.0	46.7	39.7
46	42.3	39.0		53.8	42.8	40.1	55.3	45.0	38.8	54.5	45.0	39.0
53	37.7			50.7	41.7	39.7	50.9	42.8	37.9	49.6	43.7	38.6
59				46.9	39.9	39.2	47.0	39.9	36.8	45.9	41.0	37.5
66				43.0	38.4	38.8	43.4	37.9	35.9	42.3	39.7	36.6
72				39.9	36.2	38.1	40.3	37.0	35.1	39.0	37.9	35.5
79				35.9	34.6	37.3	36.6	34.4	34.0	36.4	35.3	33.3
85				31.7	32.2		32.8	32.4	32.8	33.5	33.1	31.3
92				28.0	28.2		28.7	29.1		29.8	29.8	29.1
98							24.9	25.6		26.2	26.7	26.9
105							22.0	22.3		23.1	23.6	
112										20.3	20.7	
118										17.9	18.3	
125										14.6		

110,230 lbs lbs x 1,000 **SAE**

ft	143.4 ft + 3.6 ft + 15.4 ft			186.0 ft + 3.6 ft + 15.4 ft			196.9 ft + 3.6 ft + 15.4 ft		
	0°	20°	40°	0°	20°	40°	0°	20°	40°
23	47.4								
26	47.0								
30	45.2	39.9							
33	43.4	38.6		24.7					
36	41.9	37.3	34.4	24.7			22.3		
39	40.3	36.2	33.3	24.7	24.7		22.3		
46	37.7	34.0	31.7	24.7	23.6	22.5	22.3	22.0	20.9
53	35.5	32.2	30.2	24.0	22.5	21.4	22.3	20.9	20.1
59	33.5	30.6	28.9	22.7	21.2	20.3	21.2	19.8	19.0
66	31.7	29.3	27.6	21.4	20.3	19.4	20.1	19.0	18.3
72	30.4	28.0	26.7	20.3	19.4	18.7	19.0	18.1	17.4
79	29.1	26.9	25.8	19.4	18.5	17.9	18.1	17.4	16.8
85	28.0	26.0	24.9	18.5	17.9	17.4	17.2	16.5	16.1
92	26.7	25.4	24.3	17.6	17.0	16.5	16.3	15.9	15.4
98	25.1	24.7	23.8	17.0	16.3	16.1	15.7	15.2	15.0
105	23.6	23.6	23.4	16.3	15.7	15.4	15.2	14.6	14.3
112	20.9	21.4	21.4	15.7	15.2	15.0	14.6	14.1	13.9
118	18.7	19.2	19.2	15.0	14.6	14.3	14.1	13.7	13.4
125	16.8	17.2	17.2	14.6	14.1	13.9	13.7	13.2	13.0
131	14.8	15.2		14.1	13.7	13.7	12.8	12.8	12.6
144	11.7	11.9		13.0	12.8	12.6	11.0	11.2	11.2
158				10.6	10.8	10.8	9.7	9.7	9.9
171				8.6	8.6		8.2	8.2	8.6
184				6.6	6.8		6.4	6.6	
197							4.9	5.1	

Lifting capacities / Capacidades de elevación

79,366 lbs lbs x 1,000 **SAE**

ft	43.3 ft + 3.6 ft + 15.4 ft			86.3 ft + 3.6 ft + 15.4 ft			100.4 ft + 3.6 ft + 15.4 ft			114.8 ft + 3.6 ft + 15.4 ft		
	0°	20°	40°	0°	20°	40°	0°	20°	40°	0°	20°	40°
10	89.3											
12	84.3	59.8		84.0								
13	79.9	57.7		84.0								
15	75.8	55.6	45.7	83.1			78.3					
16	72.3	53.8	44.7	80.9	58.0		76.1					
20	69.9	52.0	43.2	78.3	56.0		73.6	57.1		67.0		
23	64.4	50.6	42.3	74.5	52.9	43.7	71.2	55.6		67.0	56.4	
26	59.8	47.9	41.2	70.1	50.5	43.2	67.5	53.4	43.2	67.0	54.7	
30	55.9	45.7	40.3	66.4	49.4	42.5	64.2	51.4	42.5	67.0	52.9	42.3
33	51.8	43.8	39.5	63.1	48.1	41.7	62.6	49.2	41.7	66.8	50.7	41.2
36	49.4	42.1	39.0	59.5	46.1	41.2	59.7	47.4	40.8	63.3	48.5	40.3
39	45.9	40.6	38.6	56.2	44.5	40.8	57.3	46.1	40.1	60.0	46.7	39.7
46	42.3	39.0		53.8	42.8	40.1	55.3	45.0	38.8	54.5	45.0	39.0
53	37.7			50.7	41.7	39.7	50.9	42.8	37.9	49.6	43.7	38.6
59				47.0	39.9	39.2	47.0	39.9	36.8	45.9	41.0	37.5
66				41.4	38.4	38.8	39.7	37.9	35.9	40.8	39.7	36.6
72				35.3	36.2	36.6	33.7	34.6	35.1	34.6	35.7	35.5
79				30.4	31.1	31.3	28.7	29.3	30.0	29.8	30.6	31.1
85				26.2	26.7		24.3	24.9	25.1	25.6	26.2	26.7
92				22.7	23.1		20.7	21.4		21.8	22.5	22.7
98							17.6	18.3		19.0	19.4	19.6
105							15.0	15.2		16.3	16.5	
112										13.9	14.1	
118										11.9	12.1	
125										10.1		

79,633 lbs lbs x 1,000 **SAE**

ft	143.4 ft + 3.6 ft + 15.4 ft			186.0 ft + 3.6 ft + 15.4 ft			196.8 ft + 3.6 ft + 15.4 ft		
	0°	20°	40°	0°	20°	40°	0°	20°	40°
23	47.4								
26	47.0								
30	45.2	39.9							
33	43.4	38.6		24.7					
36	41.9	37.3	34.4	24.7			22.3		
39	40.3	36.2	33.3	24.7	24.7		22.3		
46	37.7	34.0	31.7	24.7	23.6	22.5	22.3	22.0	20.9
53	35.5	32.2	30.2	24.0	22.5	21.4	22.3	20.9	20.1
59	33.5	30.6	28.9	22.7	21.2	20.3	21.2	19.8	19.0
66	31.7	29.3	27.6	21.4	20.3	19.4	20.1	19.0	18.3
72	30.4	28.0	26.7	20.3	19.4	18.7	19.0	18.1	17.4
79	29.1	26.9	25.8	19.4	18.5	17.9	18.1	17.4	16.8
85	26.2	26.0	24.9	18.5	17.9	17.4	17.2	16.5	16.1
92	23.1	23.1	24.0	17.6	17.0	16.5	16.3	15.9	15.4
98	19.8	20.7	21.2	17.0	16.3	16.1	15.7	15.2	15.0
105	17.2	17.9	18.3	16.3	15.7	15.4	15.2	14.6	14.3
112	14.8	15.4	15.9	15.7	15.2	15.0	14.6	14.1	13.9
118	12.8	13.4	13.7	14.1	14.6	14.3	14.1	13.7	13.4
125	11.2	11.5	11.7	12.6	13.0	13.7	12.6	13.0	13.0
131	9.5	9.7		11.2	11.7	11.7	11.2	11.5	11.7
144	6.8	6.8		8.2	8.8	8.8	8.2	8.8	8.8
158				6.2	6.4	6.4	6.2	6.4	6.4
171				4.2	4.4		4.2	4.4	4.4
184				2.6	2.9		2.6	2.6	

					52,910 lbs	lbs x 1,000	SAE
--	--	--	--	--	-------------------	-------------	------------

	43.3 ft + 3.6 ft + 15.4 ft			86.3 ft + 3.6 ft + 15.4 ft			100.4 ft + 3.6 ft + 15.4 ft			114.8 ft + 3.6 ft + 15.4 ft		
	0°	20°	40°	0°	20°	40°	0°	20°	40°	0°	20°	40°
10	89.3											
12	84.3	59.7		84.0								
13	79.9	57.8		84.0								
15	75.8	55.6	45.6	83.1			78.3					
16	72.3	53.8	44.8	80.9	58.0		76.1					
20	69.9	52.0	43.2	78.3	56.0		73.6	57.1		67.0		
23	64.4	50.5	42.3	74.5	52.9	43.7	71.2	55.6		67.0	56.4	
26	59.8	47.8	41.2	70.1	50.5	43.2	67.5	53.4	43.2	67.0	54.7	
30	55.9	45.6	40.3	66.4	49.4	42.5	64.2	51.4	42.5	67.0	52.9	42.3
33	51.8	43.9	39.5	63.1	48.1	41.7	62.6	49.2	41.7	66.8	50.7	41.2
36	49.4	42.1	39.0	59.5	46.1	41.2	59.7	47.4	40.8	63.3	48.5	40.3
39	45.9	40.6	38.6	56.2	44.5	40.8	57.3	46.1	40.1	60.0	46.7	39.7
46	42.3	39.0		53.8	42.8	40.1	55.3	45.0	38.8	52.7	45.0	39.0
53	37.7			47.2	41.7	39.7	45.4	42.8	37.9	45.4	43.7	38.6
59				38.4	39.7	39.2	36.4	37.9	36.8	37.7	38.4	37.5
66				31.5	32.6	33.3	29.5	30.9	31.3	30.9	32.2	32.2
72				26.2	27.1	27.6	24.0	25.1	26.0	25.6	26.7	26.9
79				21.8	22.3	22.7	19.6	20.7	21.2	20.9	21.8	22.5
85				18.3	18.7		16.1	16.8	17.2	17.2	18.3	18.5
92				15.2	15.4		13.0	13.7		14.3	15.0	15.2
98							10.6	11.0		11.7	12.1	12.6
105							8.6	8.8		9.5	9.9	
112										7.7	7.9	
118										6.2	6.4	
125										4.9		

					52,910 lbs	lbs x 1,000	SAE
--	--	--	--	--	-------------------	-------------	------------

	143.4 ft + 3.6 ft + 15.4 ft			186.0 ft + 3.6 ft + 15.4 ft			196.8 ft + 3.6 ft + 15.4 ft		
	0°	20°	40°	0°	20°	40°	0°	20°	40°
23	47.4								
26	47.0								
30	45.2	39.9							
33	43.4	38.6		24.7					
36	41.9	37.3	34.4	24.7			22.3		
39	40.3	36.2	33.3	24.7	24.7		22.3		
46	37.7	34.0	31.7	24.7	23.6	22.5	22.3	22.0	20.9
53	35.5	32.2	30.2	24.0	22.5	21.4	22.3	20.9	20.1
59	33.5	30.6	28.9	22.7	21.2	20.3	21.2	19.8	19.0
66	31.7	29.3	27.6	21.4	20.3	19.4	20.1	19.0	18.3
72	26.7	27.6	26.7	20.3	19.4	18.7	19.0	18.1	17.4
79	22.3	23.4	23.4	19.4	18.5	17.9	18.1	17.4	16.8
85	18.5	19.4	19.8	18.5	17.9	17.4	17.2	16.5	16.1
92	15.4	16.3	16.8	17.2	17.0	16.5	16.3	15.9	15.4
98	12.8	13.7	14.1	14.8	15.0	15.9	14.3	15.2	15.0
105	10.6	11.2	11.7	12.3	13.0	13.4	12.3	13.0	13.2
112	8.8	9.3	9.5	10.4	11.2	11.5	10.4	11.2	11.5
118	7.1	7.5	7.7	8.8	9.3	9.7	8.8	9.3	9.7
125	5.5	6.2	6.2	7.3	7.7	7.9	7.3	7.7	7.9
131	4.4	4.6		6.2	6.4	6.6	5.7	6.4	6.6
144		2.4		3.7	4.2	4.2	3.7	4.0	4.2

Lifting capacities / Capacidades de elevación

26,455 lbs lbs x 1,000 SAE

ft	43.3 ft + 3.6 ft + 15.4 ft			86.3 ft + 3.6 ft + 15.4 ft			100.4 ft + 3.6 ft + 15.4 ft			114.8 ft + 3.6 ft + 15.4 ft		
	0°	20°	40°	0°	20°	40°	0°	20°	40°	0°	20°	40°
10	89.3											
12	84.2	59.7		84.0								
13	79.8	57.8		84.0								
15	75.8	55.6	45.6	83.1			78.3					
16	72.3	53.8	44.8	80.9	58.0		76.1					
20	69.9	52.0	43.2	78.3	56.0		73.6	57.1		67.0		
23	64.4	50.5	42.3	74.5	52.9	43.7	71.2	55.6		67.0	56.4	
26	59.7	47.8	41.2	70.1	50.5	43.2	67.5	53.4	43.2	67.0	54.7	
30	55.8	45.6	40.3	66.4	49.4	42.5	64.2	51.4	42.5	67.0	52.9	42.3
33	51.8	43.9	39.5	63.1	48.1	41.7	62.6	49.2	41.7	61.9	50.7	41.2
36	49.4	42.1	39.0	59.5	46.1	41.2	54.7	47.4	40.8	53.8	48.5	40.3
39	45.9	40.6	38.6	52.2	44.5	40.8	47.6	46.1	40.1	47.2	46.7	39.7
46	42.3	39.0		43.0	42.8	40.1	38.4	39.2	38.8	38.1	39.0	39.0
53	37.3			33.1	34.6	35.3	30.9	32.2	33.5	31.3	32.4	35.1
59				26.0	27.1	28.0	23.8	25.1	26.5	24.9	26.2	28.0
66				20.3	21.4	22.0	18.3	19.4	20.3	19.4	20.9	21.8
72				16.1	16.8	17.2	13.9	15.0	15.4	15.0	16.3	17.0
79				12.6	13.0	13.4	10.4	11.5	11.9	11.7	12.6	13.4
85				9.7	10.1		7.7	8.6	8.8	9.0	9.7	10.1
92				7.5	7.7		5.3	6.2		6.6	7.3	7.5
98							3.3	4.0		4.6	5.1	5.3
105										2.9	3.3	

26,455 lbs lbs x 1,000 SAE

ft	143.4 ft + 3.6 ft + 15.4 ft			186.0 ft + 3.6 ft + 15.4 ft			196.8 ft + 3.6 ft + 15.4 ft		
	0°	20°	40°	0°	20°	40°	0°	20°	40°
23	47.4								
26	47.0								
30	45.2	39.9							
33	43.4	38.6		24.7					
36	41.9	37.3	34.4	24.7			22.3		
39	40.3	36.2	33.3	24.7	24.7		22.3		
46	35.7	34.0	31.7	24.7	23.6	22.5	22.3	22.0	20.9
53	29.8	30.4	30.2	24.0	22.5	21.4	22.3	20.9	20.1
59	24.9	26.9	28.4	22.7	21.2	20.3	21.2	19.8	19.0
66	20.7	22.3	23.4	20.1	20.3	19.4	19.0	19.0	18.3
72	16.5	17.6	18.7	17.4	18.5	18.7	16.8	17.9	17.4
79	13.0	14.1	14.8	14.6	15.7	16.1	14.3	15.4	16.3
85	10.1	11.2	11.7	12.1	13.0	13.4	12.1	12.8	13.7
92	7.7	8.6	9.0	9.7	10.4	11.0	9.7	10.4	11.0
98	5.7	6.6	6.8	7.5	8.2	8.8	7.5	8.2	8.8
105	4.2	4.6	5.1	5.7	6.6	7.1	5.7	6.6	7.1
112	2.6	3.1	3.3	4.4	4.9	5.3	4.4	4.9	5.3
118				2.9	3.7	4.0	2.9	3.3	4.0
125					2.4	2.6		2.4	2.6

0 lbs lbs x 1,000 SAE

ft	43.3 ft + 3.6 ft + 15.4 ft			86.3 ft + 3.6 ft + 15.4 ft			100.4 ft + 3.6 ft + 15.4 ft			114.8 ft + 3.6 ft + 15.4 ft		
	0°	20°	40°	0°	20°	40°	0°	20°	40°	0°	20°	40°
10	89.3											
12	84.2	59.7		84.0								
13	79.8	57.8		84.0								
15	75.8	55.6	45.6	83.1			78.3					
16	72.3	53.8	44.8	80.9	58.0		76.1					
20	69.9	52.0	43.2	78.3	56.0		73.6	57.1		67.0		
23	64.4	50.5	42.3	74.5	52.9	43.7	71.2	55.6		67.0	56.4	
26	59.7	47.8	41.2	64.4	50.5	43.2	57.5	53.4	43.2	55.8	54.7	
30	55.8	45.6	40.3	53.1	49.4	42.5	47.4	51.1	42.5	46.3	49.8	42.3
33	51.8	43.9	39.5	44.5	47.6	41.7	39.7	42.8	41.7	39.0	42.1	41.2
36	48.7	42.1	39.0	39.0	41.7	41.2	33.5	36.4	38.8	33.3	35.9	38.4
39	40.8	40.6	38.6	35.1	37.0	39.7	28.4	30.9	33.1	28.4	30.9	33.1
46	30.0	30.9		25.6	27.6	29.3	22.7	25.1	26.9	23.4	25.6	27.1
53	22.5			17.9	19.8	21.2	15.9	17.6	19.2	17.2	19.2	20.7
59				12.6	14.1	15.0	10.6	12.1	13.4	11.9	13.7	14.8
66				8.8	9.9	10.6	6.8	7.9	9.0	7.9	9.5	10.4
72				5.7	6.6	7.1	3.7	4.9	5.3	4.9	6.2	6.8
79				3.3	4.0	4.4			2.6	2.4	3.3	4.2

0 lbs lbs x 1,000 SAE

ft	143.4 ft + 3.6 ft + 15.4 ft			186.0 ft + 3.6 ft + 15.4 ft			196.9 ft + 3.6 ft + 15.4 ft		
	0°	20°	40°	0°	20°	40°	0°	20°	40°
23	47.4								
26	47.0								
30	43.2	39.9							
33	36.8	38.6		24.7					
36	31.5	34.2	34.4	24.7			22.3		
39	27.3	29.5	31.5	24.7	24.7		22.3		
46	21.8	23.6	25.1	20.3	21.8	22.5	19.6	21.2	20.9
53	17.2	19.0	20.3	16.5	18.1	19.2	16.3	17.4	17.9
59	13.0	14.6	15.4	13.4	14.6	15.9	13.0	14.3	15.4
66	9.5	11.0	11.9	10.4	11.7	12.6	9.9	11.2	12.1
72	6.4	7.5	8.6	7.7	8.8	9.7	7.5	8.6	9.5
79	4.0	4.9	5.5	5.5	6.6	7.3	5.3	6.4	7.1
85			3.3		4.6	5.3			5.1





Lifting heights / Alturas de elevación



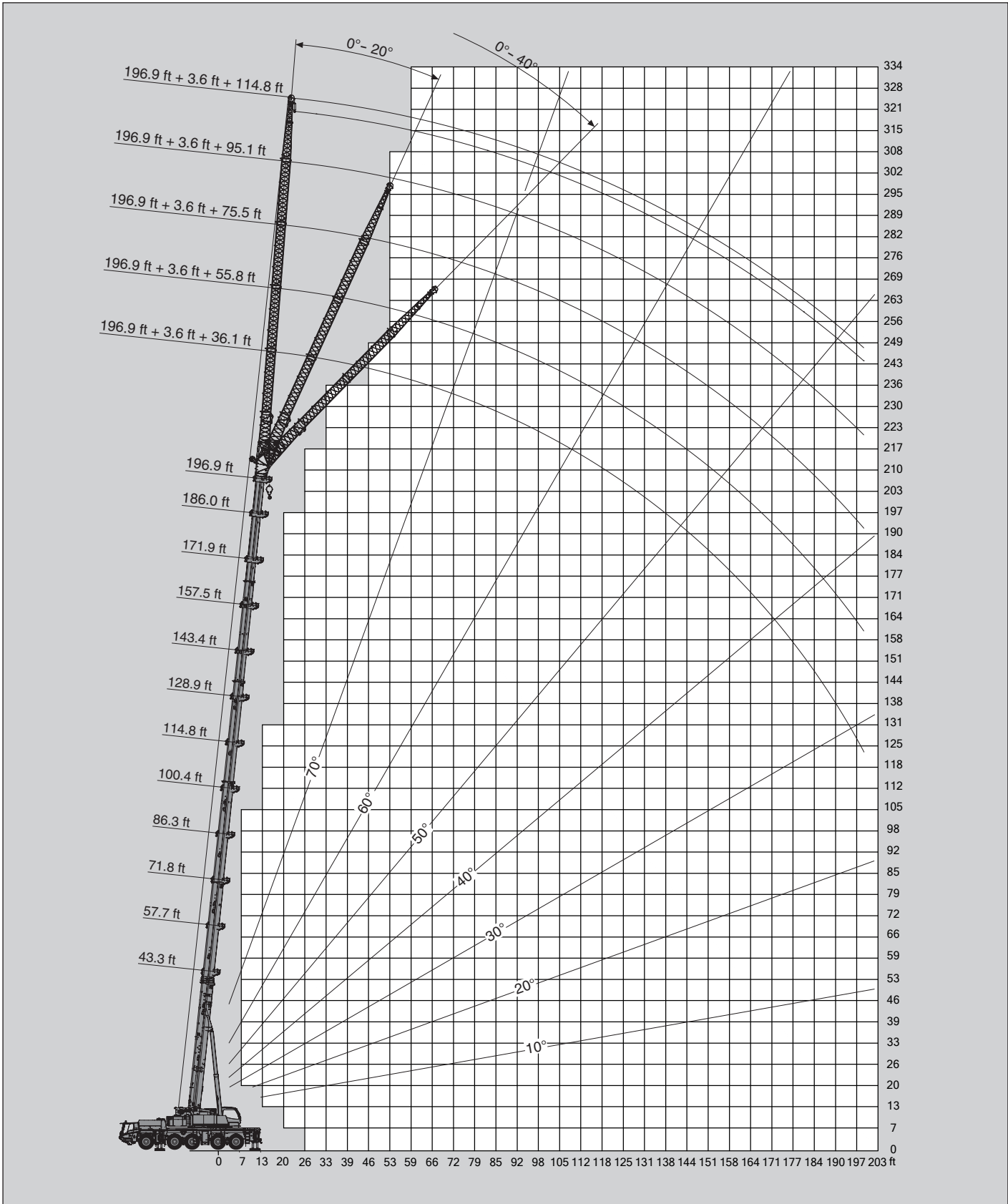

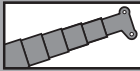
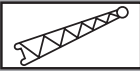

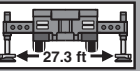

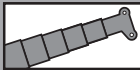
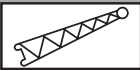

110,230 lbs
lbs x 1,000
SAE

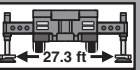

     110,230 lbs lbs x 1,000 SAE															
 ft	186.0 ft + 3.6 ft + 36.1 ft			186.0 ft + 3.6 ft + 55.8 ft			186.0 ft + 3.6 ft + 75.5 ft			186.0 ft + 3.6 ft + 95.1 ft			186.0 ft + 3.6 ft + 114.8 ft		
	0°	20°	40°	0°	20°	40°	0°	20°	40°	0°	20°	40°	0°	20°	40°
36	17.0														
39	17.0			12.8			9.7								
46	17.0			12.8			9.7			7.7					
53	17.0	16.5		12.8			9.7			7.7			5.3		
59	17.0	16.1		12.8			9.7			7.7			5.3		
66	17.0	15.7	13.7	12.8	12.8		9.7			7.7			5.3		
72	17.0	15.0	13.4	12.8	12.3		9.7			7.7			5.3		
79	16.1	14.3	13.0	12.8	11.7		9.7	9.5		7.7			5.3		
85	15.4	13.7	12.8	12.8	11.2	10.4	9.7	9.3		7.5			5.3		
92	14.8	13.2	12.3	12.3	10.8	9.9	9.7	9.0		7.5	6.4		5.3		
98	14.1	12.8	11.9	11.9	10.4	9.7	9.7	8.8		7.3	6.4		5.3		
105	13.7	12.3	11.5	11.5	10.1	9.3	9.7	8.4	7.7	7.3	6.2		5.1	4.4	
112	13.0	11.9	11.2	11.0	9.7	9.0	9.3	8.2	7.5	7.1	6.0		5.1	4.2	
118	12.6	11.5	10.8	10.6	9.5	8.8	9.0	7.9	7.3	6.8	6.0		4.9	4.2	
125	12.1	11.2	10.6	10.1	9.0	8.6	8.6	7.5	7.1	6.8	5.7	5.3	4.9	4.0	
131	11.7	10.8	10.4	9.9	8.8	8.4	8.4	7.3	6.8	6.6	5.7	5.1	4.6	4.0	
144	11.0	10.4	9.9	9.3	8.4	7.9	7.7	6.8	6.4	6.4	5.5	4.9	4.4	3.7	
158	10.4	9.7	9.5	8.8	7.9	7.5	7.3	6.4	6.2	6.2	5.3	4.6	4.2	3.5	
171	9.5	9.3	9.0	8.4	7.5	7.3	6.8	6.2	5.7	5.7	5.1	4.4	4.2	3.5	
184	7.7	8.2	7.7	7.9	7.3	7.1	6.6	5.7	5.5	5.3	4.6	4.2	4.0	3.3	
197	6.2	6.6		6.4	7.1	6.8	6.2	5.5	5.3	5.1	4.4	4.0	3.7	3.3	
210	4.6	5.1		5.1	5.5	6.0	5.3	5.3	5.1	4.9	4.2	4.0	3.5	3.1	
223				4.0	4.4		4.2	4.9	4.9	4.0	4.0	3.7	3.3	3.1	
236				2.9	3.1		2.9	3.7	4.0	3.1	3.7	3.7	2.6	2.9	
249											2.9	3.3			2.6

     110,230 lbs lbs x 1,000 SAE															
 ft	196.8 ft + 3.6 ft + 36.1 ft			196.8 ft + 3.6 ft + 55.8 ft			196.8 ft + 3.6 ft + 75.5 ft			196.8 ft + 3.6 ft + 95.1 ft			196.8 ft + 3.6 ft + 114.8 ft		
	0°	20°	40°	0°	20°	40°	0°	20°	40°	0°	20°	40°	0°	20°	40°
39	14.3			11.0											
46	14.3			11.0			8.6			6.6					
53	14.3			11.0			8.6			6.6			5.1		
59	14.3	14.3		11.0			8.6			6.6			5.1		
66	14.3	14.3		11.0	11.0		8.6			6.6			5.1		
72	14.3	14.1	13.0	11.0	11.0		8.6			6.6			5.1		
79	14.3	13.4	12.6	11.0	11.0		8.6	8.6		6.6			5.1		
85	14.3	13.0	12.1	11.0	10.8	9.9	8.6	8.6		6.6			5.1		
92	13.9	12.3	11.7	11.0	10.4	9.5	8.6	8.6		6.6	6.2		5.1		
98	13.2	11.9	11.2	11.0	9.9	9.3	8.6	8.4		6.6	6.2		4.9		
105	12.8	11.7	10.8	10.8	9.5	8.8	8.6	7.9	7.5	6.6	6.0		4.9		
112	12.3	11.2	10.6	10.4	9.3	8.6	8.6	7.7	7.1	6.6	6.0		4.9		
118	11.7	10.8	10.4	9.9	8.8	8.4	8.4	7.5	6.8	6.6	5.7		4.6		
125	11.2	10.6	9.9	9.7	8.6	8.2	8.2	7.3	6.6	6.6	5.7		4.6		
131	11.0	10.1	9.7	9.3	8.4	7.9	7.9	7.1	6.4	6.4	5.5		4.4		
144	10.1	9.7	9.3	8.8	7.9	7.5	7.3	6.6	6.2	6.2	5.3		4.4		
158	9.0	9.0	8.8	8.2	7.5	7.1	6.8	6.2	5.7	5.7	5.1		4.2		
171	7.9	8.2	8.2	7.3	7.1	6.8	6.4	5.7	5.5	5.3	4.6		4.0		
184	6.8	7.1	7.3	6.4	6.6	6.6	6.0	5.5	5.3	5.1	4.4		3.7		
197	5.7	6.2	6.4	5.5	6.0	6.2	5.3	5.3	5.1	4.6	4.2		3.5		
210	4.6	4.9		4.6	5.1	5.3	4.4	4.9	4.9	4.0	4.0		2.9		
223	3.3	3.7		3.7	4.2	4.4	3.7	4.2	4.4	3.5	3.7		2.4		
236				2.6	2.9		2.6	3.3	4.0	2.9	3.3				
249											2.9				

Lifting capacities / Capacidades de elevación

79,366 lbs lbs x 1,000 **SAE**

ft	186.0 ft + 3.6 ft + 36.1 ft			186.0 ft + 3.6 ft + 55.8 ft			186.0 ft + 3.6 ft + 75.5 ft			186.0 ft + 3.6 ft + 95.1 ft			186.0 ft + 3.6 ft + 114.8 ft		
	0°	20°	40°	0°	20°	40°	0°	20°	40°	0°	20°	40°	0°	20°	40°
36	17.0														
39	17.0			12.8			9.7								
46	17.0			12.8			9.7			7.7					
53	17.0	16.5		12.8			9.7			7.7			5.3		
59	17.0	16.1		12.8			9.7			7.7			5.3		
66	17.0	15.7	13.7	12.8	12.8		9.7			7.7			5.3		
72	17.0	15.0	13.4	12.8	12.3		9.7			7.7			5.3		
79	16.1	14.3	13.0	12.8	11.7		9.7	9.5		7.7			5.3		
85	15.4	13.7	12.8	12.8	11.2	10.4	9.7	9.3		7.5			5.3		
92	14.8	13.2	12.3	12.3	10.8	9.9	9.7	9.0		7.5	6.4		5.3		
98	14.1	12.8	11.9	11.9	10.4	9.7	9.7	8.8		7.3	6.4		5.3		
105	13.7	12.3	11.5	11.5	10.1	9.3	9.7	8.4	7.7	7.3	6.2		5.1	4.4	
112	13.0	11.9	11.2	11.0	9.7	9.0	9.3	8.2	7.5	7.1	6.0		5.1	4.2	
118	12.6	11.5	10.8	10.6	9.5	8.8	9.0	7.9	7.3	6.8	6.0		4.9	4.2	
125	12.1	11.2	10.6	10.1	9.0	8.6	8.6	7.5	7.1	6.8	5.7	5.3	4.9	4.0	
131	11.7	10.8	10.4	9.9	8.8	8.4	8.4	7.3	6.8	6.6	5.7	5.1	4.6	4.0	
144	9.5	10.4	9.9	9.3	8.4	7.9	7.7	6.8	6.4	6.4	5.5	4.9	4.4	3.7	
158	7.3	8.2	8.6	7.7	7.9	7.5	7.3	6.4	6.2	6.2	5.3	4.6	4.2	3.5	
171	5.3	6.2	6.6	5.7	7.1	7.3	6.0	6.2	5.7	5.7	5.1	4.4	4.2	3.5	
184	4.0	4.4	7.7	4.2	5.1	5.7	4.4	5.7	5.5	4.6	4.6	4.2	4.0	3.3	
197		2.9		2.9	3.7	4.2	3.1	4.4	5.1	3.1	4.4	4.0	3.3	3.3	
210						2.6		2.9	3.7		3.3	4.0	3.1	3.1	
223											3.1	4.0	2.6	2.6	

79,366 lbs lbs x 1,000 **SAE**

ft	196.8 ft + 3.6 ft + 36.1 ft			196.8 ft + 3.6 ft + 55.8 ft			196.8 ft + 3.6 ft + 75.5 ft			196.8 ft + 3.6 ft + 95.1 ft			196.8 ft + 3.6 ft + 114.8 ft		
	0°	20°	40°	0°	20°	40°	0°	20°	40°	0°	20°	40°	0°	20°	40°
39	14.3			11.0											
46	14.3			11.0			8.6			6.6					
53	14.3			11.0			8.6			6.6			5.1		
59	14.3	14.3		11.0			8.6			6.6			5.1		
66	14.3	14.3		11.0	11.0		8.6			6.6			5.1		
72	14.3	14.1	13.0	11.0	11.0		8.6			6.6			5.1		
79	14.3	13.4	12.6	11.0	11.0		8.6	8.6		6.6			5.1		
85	14.3	13.0	12.1	11.0	10.8	9.9	8.6	8.6		6.6			5.1		
92	13.9	12.3	11.7	11.0	10.4	9.5	8.6	8.6		6.6	6.2		5.1		
98	13.2	11.9	11.2	11.0	9.9	9.3	8.6	8.4		6.6	6.2		4.9		
105	12.8	11.7	10.8	10.8	9.5	8.8	8.6	7.9	7.5	6.6	6.0		4.9		
112	12.3	11.2	10.6	10.4	9.3	8.6	8.6	7.7	7.1	6.6	6.0		4.9		
118	11.7	10.8	10.4	9.9	8.8	8.4	8.4	7.5	6.8	6.6	5.7		4.6		
125	11.2	10.6	9.9	9.7	8.6	8.2	8.2	7.3	6.6	6.6	5.7		4.6		
131	11.0	10.1	9.7	9.3	8.4	7.9	7.9	7.1	6.4	6.4	5.5		4.4		
144	9.3	9.7	9.3	8.8	7.9	7.5	7.3	6.6	6.2	6.2	5.3		4.4		
158	7.1	7.9	8.8	7.3	7.5	7.1	6.8	6.2	5.7	5.7	5.1		4.2		
171	5.1	6.2	6.6	5.5	6.8	6.8	5.7	5.7	5.5	5.3	4.6		4.0		
184	3.7	4.4	4.6	4.0	5.1	5.7	4.2	5.5	5.3	4.4	4.4		3.7		
197		2.9	3.1	2.6	3.7	4.2	2.9	4.2	5.1	2.9	4.2		3.1		
210						2.6		2.9	3.7		3.3				

52,910 lbs lbs x 1,000 SAE																
 ft	186.0 ft + 3.6 ft + 36.1 ft			186.0 ft + 3.6 ft + 55.8 ft			186.0 ft + 3.6 ft + 75.5 ft			186.0 ft + 3.6 ft + 95.1 ft			186.0 ft + 3.6 ft + 114.8 ft			
	0°	20°	40°	0°	20°	40°	0°	20°	40°	0°	20°	40°	0°	20°	40°	
36	17.0															
39	17.0			12.8			9.7									
46	17.0			12.8			9.7			7.7						
53	17.0	16.5		12.8			9.7			7.7			5.3			
59	17.0	16.1		12.8			9.7			7.7			5.3			
66	17.0	15.7	13.7	12.8	12.8		9.7			7.7			5.3			
72	17.0	15.0	13.4	12.8	12.3		9.7			7.7			5.3			
79	16.1	14.3	13.0	12.8	11.7		9.7	9.5		7.7			5.3			
85	15.4	13.7	12.8	12.8	11.2	10.4	9.7	9.3		7.5			5.3			
92	14.8	13.2	12.3	12.3	10.8	9.9	9.7	9.0		7.5	6.4		5.3			
98	14.1	12.8	11.9	11.9	10.4	9.7	9.7	8.8		7.3	6.4		5.3			
105	13.4	12.3	11.5	11.5	10.1	9.3	9.7	8.4	7.7	7.3	6.2		5.1	4.4		
112	11.7	11.9	11.2	11.0	9.7	9.0	9.3	8.2	7.5	7.1	6.0		5.1	4.2		
118	9.9	11.5	10.8	10.4	9.5	8.8	9.0	7.9	7.3	6.8	6.0		4.9	4.2		
125	8.6	9.9	10.6	9.0	9.0	8.6	8.6	7.5	7.1	6.8	5.7	5.3	4.9	4.0		
131	7.1	8.6	9.5	7.5	8.8	8.4	7.9	7.3	6.8	6.6	5.7	5.1	4.6	4.0		
144	4.9	6.2	6.8	5.3	7.1	7.9	5.5	6.8	6.4	5.7	5.5	4.9	4.4	3.7		
158	3.1	4.0	4.6	3.3	4.9	6.2	4.0	5.5	6.2	4.0	5.3	4.6	4.2	3.5		
171			2.6		3.1	4.0		4.0	5.1	2.4	4.6	4.4	2.4	3.5		
184						2.4		2.4	3.3		2.9	4.2		3.3		
197											2.9					

52,910 lbs lbs x 1,000 SAE																
 ft	196.8 ft + 3.6 ft + 36.1 ft			196.8 ft + 3.6 ft + 55.8 ft			196.8 ft + 3.6 ft + 75.5 ft			196.8 ft + 3.6 ft + 95.1 ft			196.8 ft + 3.6 ft + 114.8 ft			
	0°	20°	40°	0°	20°	40°	0°	20°	40°	0°	20°	40°	0°	20°	40°	
39	14.3			11.0												
46	14.3			11.0			8.6			6.6						
53	14.3			11.0			8.6			6.6			5.1			
59	14.3	14.3		11.0			8.6			6.6			5.1			
66	14.3	14.3		11.0	11.0		8.6			6.6			5.1			
72	14.3	14.1	13.0	11.0	11.0		8.6			6.6			5.1			
79	14.3	13.4	12.6	11.0	11.0		8.6	8.6		6.6			5.1			
85	14.3	13.0	12.1	11.0	10.8	9.9	8.6	8.6		6.6			5.1			
92	13.9	12.3	11.7	11.0	10.4	9.5	8.6	8.6		6.6	6.2		5.1			
98	13.2	11.9	11.2	11.0	9.9	9.3	8.6	8.4		6.6	6.2		4.9			
105	12.8	11.7	10.8	10.8	9.5	8.8	8.6	7.9	7.5	6.6	6.0		4.9			
112	11.7	11.2	10.6	10.4	9.3	8.6	8.6	7.7	7.1	6.6	6.0		4.9			
118	9.9	10.8	10.4	9.9	8.8	8.4	8.4	7.5	6.8	6.6	5.7		4.6			
125	8.2	9.7	9.9	8.6	8.6	8.2	8.2	7.3	6.6	6.6	5.7		4.6			
131	7.1	8.6	9.5	7.5	8.4	7.9	7.7	7.1	6.4	6.4	5.5		4.4			
144	4.9	5.7	6.8	5.1	6.8	7.5	5.3	6.6	6.2	5.5	5.3		4.4			
158	2.9	4.0	4.6	3.3	4.9	5.7	3.7	5.5	5.7	3.7	5.1		4.0			
171			2.6		2.9	4.0		3.7	5.1		4.4					
184								3.3	2.6							

Lifting capacities / Capacidades de elevación

26,455 lbs lbs x 1,000 **SAE**

ft	186.0 ft + 3.6 ft + 36.1 ft			186.0 ft + 3.6 ft + 55.8 ft			186.0 ft + 3.6 ft + 75.5 ft			186.0 ft + 3.6 ft + 95.1 ft			186.0 ft + 3.6 ft + 114.8 ft		
	0°	20°	40°	0°	20°	40°	0°	20°	40°	0°	20°	40°	0°	20°	40°
36	17.0														
39	17.0			12.8			9.7								
46	17.0			12.8			9.7								
53	17.0	16.5		12.8			9.7								
59	17.0	16.1		12.8			9.7								
66	17.0	15.7	13.7	12.8	12.8		9.7								
72	16.3	15.0	13.4	12.8	12.3		9.7								
79	13.9	14.3	13.0	12.8	11.7		9.7	9.5							
85	12.1	13.7	12.8	11.9	11.2	10.4	9.7	9.3							
92	10.4	12.1	12.3	10.4	10.8	9.9	9.7	9.0							
98	8.6	10.6	11.9	9.0	10.4	9.7	8.4	8.8							
105	7.1	8.8	10.1	7.5	9.9	9.3	7.3	8.4	7.7						
112	5.5	7.3	8.6	6.2	8.6	9.0	6.2	8.2	7.5						
118	4.2	5.7	7.1	4.6	7.1	8.8	5.1	7.9	7.3						
125	3.1	4.6	5.5	3.7	5.5	7.3	4.0	6.6	7.1						
131		3.3	4.4	2.4	4.4	6.0	2.9	5.3	6.8						
144					2.4	3.7		3.1	5.1						
158									3.1						

26,455 lbs lbs x 1,000 **SAE**

ft	196.8 ft + 3.6 ft + 36.1 ft			196.8 ft + 3.6 ft + 55.8 ft			196.8 ft + 3.6 ft + 75.5 ft			196.8 ft + 3.6 ft + 95.1 ft			196.8 ft + 3.6 ft + 114.8 ft		
	0°	20°	40°	0°	20°	40°	0°	20°	40°	0°	20°	40°	0°	20°	40°
39	14.3			11.0											
46	14.3			11.0			8.6								
53	14.3			11.0			8.6								
59	14.3	14.3		11.0			8.6								
66	14.3	14.3		11.0	11.0		8.6								
72	14.3	14.1	13.0	11.0	11.0		8.6								
79	13.4	13.4	12.6	11.0	11.0		8.6	8.6							
85	11.2	13.0	12.1	11.0	10.8	9.9	8.6	8.6							
92	9.9	12.3	11.7	9.7	10.4	9.5	8.6	8.6							
98	8.6	10.6	11.2	8.4	9.9	9.3	7.9	8.4							
105	7.1	8.8	9.7	7.1	9.5	8.8	7.1	7.9	7.5						
112	5.3	7.3	8.2	5.7	8.4	8.6	6.0	7.7	7.1						
118	4.2	5.7	6.8	4.6	6.8	8.4	4.9	7.5	6.8						
125	2.9	4.4	5.5	3.3	5.5	7.3	3.7	6.4	6.6						
131		3.1	4.4		4.4	5.7		5.3	6.4						
144						3.7		3.1	5.1						
158									2.9						

Lifting capacities / Capacidades de elevación

		 HYDRO	 27.3 ft	 360°	0 lbs	lbs x 1,000	SAE
---	---	--	--	---	--------------	-------------	------------

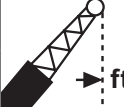
 ft	186.0 ft + 3.6 ft + 36.1 ft			196.8 ft + 3.6 ft + 36.1 ft					
	0°	20°	40°	0°	20°	40°			
36	17.0								
39	17.0			14.3					
46	17.0			14.3					
53	15.7	16.5		14.3					
59	12.3	15.7		11.9	14.3				
66	10.1	12.6	13.7	9.7	12.1				
72	8.2	10.6	12.3	7.7	10.1	11.9			
79	6.4	8.6	10.6	2.6	8.4	10.1			
85	4.6	6.8	8.8		6.6	8.4			
92		5.1	7.1		4.9	6.6			
98			5.3			5.1			
105			4.0						

Lifting heights / Alturas de elevación

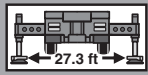
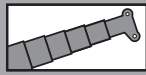

110,230 lbs

lbs x 1,000

SAE

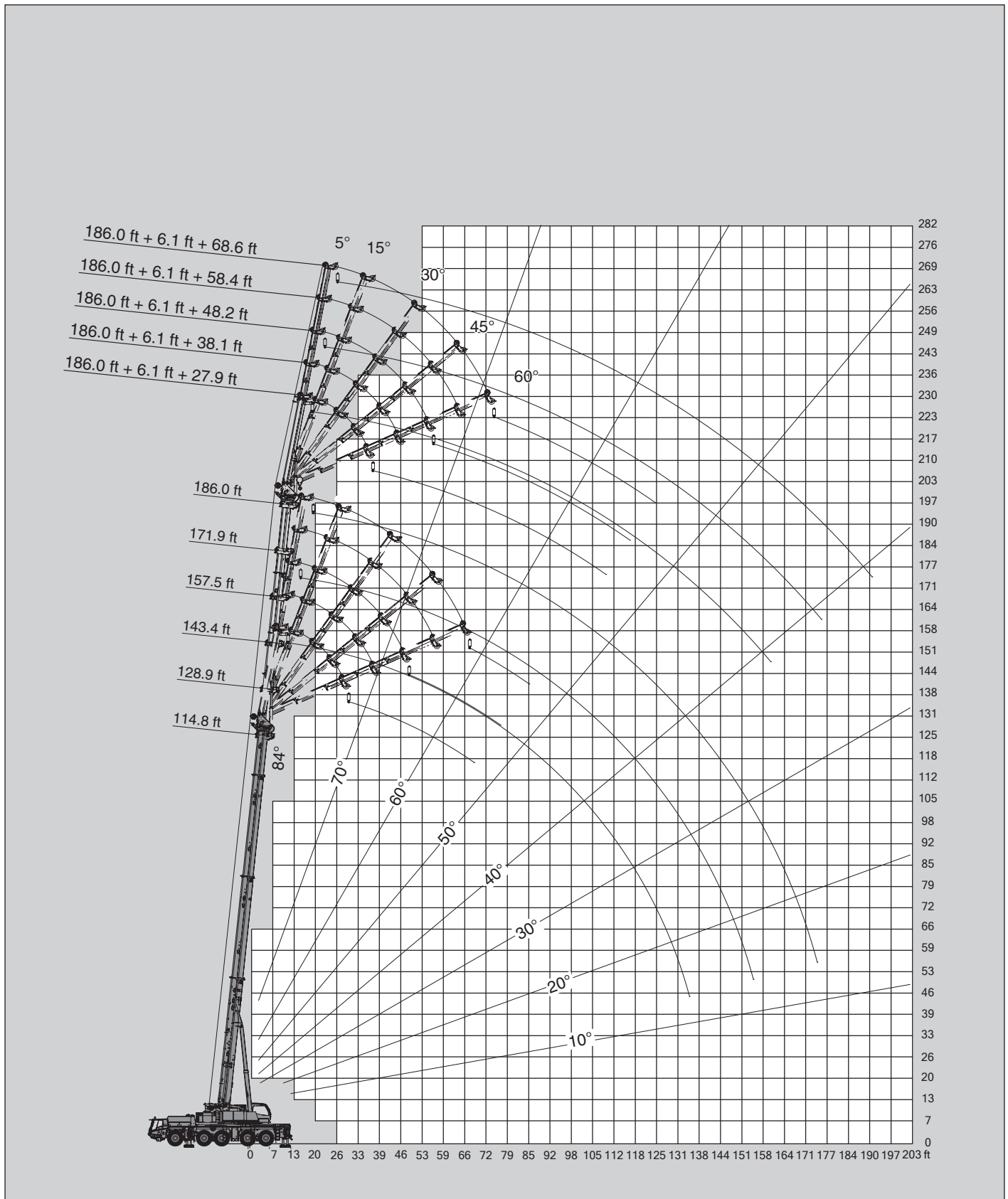

				110,230 lbs	lbs x 1,000	SAE
---	---	---	---	--------------------	-------------	------------

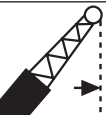
 ft	186.0 ft + 6.1 ft + 27.9 ft					186.0 ft + 6.1 ft + 38.1 ft					186.0 ft + 6.1 ft + 48.2 ft					186.0 ft + 6.1 ft + 58.4 ft					186.0 + 6.1 ft + 68.6 ft					
	5°	15°	30°	45°	60°	5°	15°	30°	45°	60°	5°	15°	30°	45°	60°	5°	15°	30°	45°	60°	5°	15°	30°	45°	60°	
39.4	18.7					15.0																				
45.9	18.7	18.1				15.0					12.8					11.2										
52.5	17.6	17.0	15.9			15.0	15.0				12.8					11.2						9.7				
59.1	16.5	15.9	15.0	14.6	14.3	15.0	14.3	13.4			12.8	12.8				11.2	11.2					9.7				
65.6	15.7	14.8	14.1	13.7	13.4	14.3	13.4	12.8	12.1		12.8	12.3	11.5			11.2	11.2					9.7	9.7			
72.2	14.6	14.1	13.4	13.0	12.8	13.4	12.8	12.1	11.7	11.5	12.3	11.7	11.0			11.2	10.8					9.7	9.7			
78.7	13.9	13.2	12.6	12.3	12.1	12.8	12.1	11.5	11.0	10.8	11.7	11.0	10.4	9.9		10.8	10.1	9.5				9.7	9.5			
85.3	13.0	12.6	11.9	11.7	11.7	12.1	11.5	10.8	10.6	10.4	11.0	10.6	9.9	9.5	9.3	10.4	9.7	9.0	8.8			9.7	9.0	8.4		
91.9	12.1	11.9	11.5	11.2	11.0	11.5	10.8	10.4	9.9	9.9	10.6	9.9	9.5	9.0	9.0	9.7	9.3	8.6	8.4	8.2		9.0	8.6	7.9		
98.4	11.5	11.2	10.8	10.6	10.6	10.8	10.4	9.9	9.5	9.5	9.9	9.5	9.0	8.6	8.6	9.3	8.8	8.2	7.9	7.9		8.6	8.2	7.7	7.3	
105	10.8	10.6	10.4	10.1	10.1	10.1	9.9	9.3	9.0	9.0	9.5	9.0	8.6	8.4	8.2	8.8	8.4	7.9	7.5	7.5		8.2	7.7	7.3	7.1	
112	10.1	9.9	9.7	9.7	9.7	9.7	9.5	9.0	8.8	8.8	9.0	8.6	8.2	7.9	7.9	8.4	7.9	7.5	7.3	7.3		7.9	7.5	7.1	6.6	
118	9.7	9.5	9.3	9.3	9.3	9.0	8.8	8.6	8.4	8.4	8.6	8.2	7.7	7.5	7.5	7.9	7.5	7.3	7.1	6.8		7.5	7.1	6.6	6.4	
125	9.3	9.0	8.8	8.6		8.6	8.4	8.2	7.9	8.2	8.2	7.9	7.5	7.3	7.3	7.7	7.3	6.8	6.6	6.6		7.1	6.8	6.4	6.2	
131	8.6	8.6	8.4	8.4		8.2	7.9	7.7	7.7		7.7	7.5	7.1	7.1	7.1	7.3	6.8	6.6	6.4	6.4		6.8	6.4	6.2	6.0	
138	8.2	8.2	7.9	7.9		7.7	7.5	7.5	7.3		7.3	7.3	6.8	6.8	6.8	7.1	6.6	6.4	6.2	6.2		6.6	6.2	5.7	5.7	
144	6.8	7.3	7.5	7.5		7.5	7.3	7.1	7.1		7.1	6.8	6.6	6.4		6.6	6.4	6.0	6.0	6.0		6.2	6.0	5.5	5.5	
151	5.5	6.0	6.2	6.2		6.6	6.8	6.8	6.6		6.6	6.4	6.4	6.2		6.4	6.2	5.7	5.7			6.0	5.7	5.3	5.3	
158	4.4	4.6	4.9	4.9		5.3	5.7	6.2	6.4		6.2	6.2	6.0	6.0		6.0	6.0	5.5	5.5			5.7	5.5	5.1	5.1	
164	3.3	3.5	3.7			4.2	4.6	5.1	5.1		5.1	5.5	5.7	5.7		5.7	5.5	5.3	5.3			5.5	5.3	4.9	4.9	
177							2.6	2.9				3.1	3.5	4.0			4.0	4.4	5.1	5.1			4.6	4.9	4.6	4.6
190																		3.1	3.3				2.9	3.5	4.2	4.2

Axle weight distribution chart / Distribución de pesos por ejes

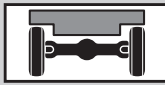

	Axle Eje	1	2	3	4	5	Total weight Peso total
	Tires 525/80 R 25 (20.50 R 25) [lbs]	25,748	25,684	27,530	27,657	27,500	134,119*

Boom to front	Total [lbs]	Axle 1 [lbs]	Axle 2 [lbs]	Axle 3 [lbs]	Axle 4 [lbs]	Axle 5 [lbs]
Base machine with equipment for USA, 16.00 R 25 tires, no counterweight, no fuel, no driver	124,296	23,913	23,866	25,439	25,617	25,461
* Fuel in carrier	992	92	91	274	268	268
* Fuel in superstructure	441	-69	-68	196	191	191
* Driver in carrier	198	150	148	-34	-33	-33
* 11.0 ton [10.0 t]** headache ball (in transport position)						
27.6 ton [25.0 t]** (1 sheave) hook block (in transport position)	662	628	622	-199	-194	-194
43.3 ft / 63 ft Mechanical offset boom extensions	3,539	1,870	1,852	-62	-61	-61
* 43.3 ft / 63 ft Hydraulic boom extensions	4,044	2,369	2,346	-227	-222	-222
* Auxiliary winch with cable	3,043	-1,444	-1,430	2,005	1,956	1,956
* Auxiliary boom point sheave (single top)	187	189	187	-64	-62	-62
* 2 nd oil cooler	101	-12	-12	42	41	41
* 20.50 R 25 tires in lieu of 16.00 R 25	1,036	207	207	207	207	207
Eddy-current brake	827	128	127	194	189	189
* Towing attachment						
* Tool box at rear	154	-66	-66	97	95	95

* Basic configuration, marked items are included ** Metric

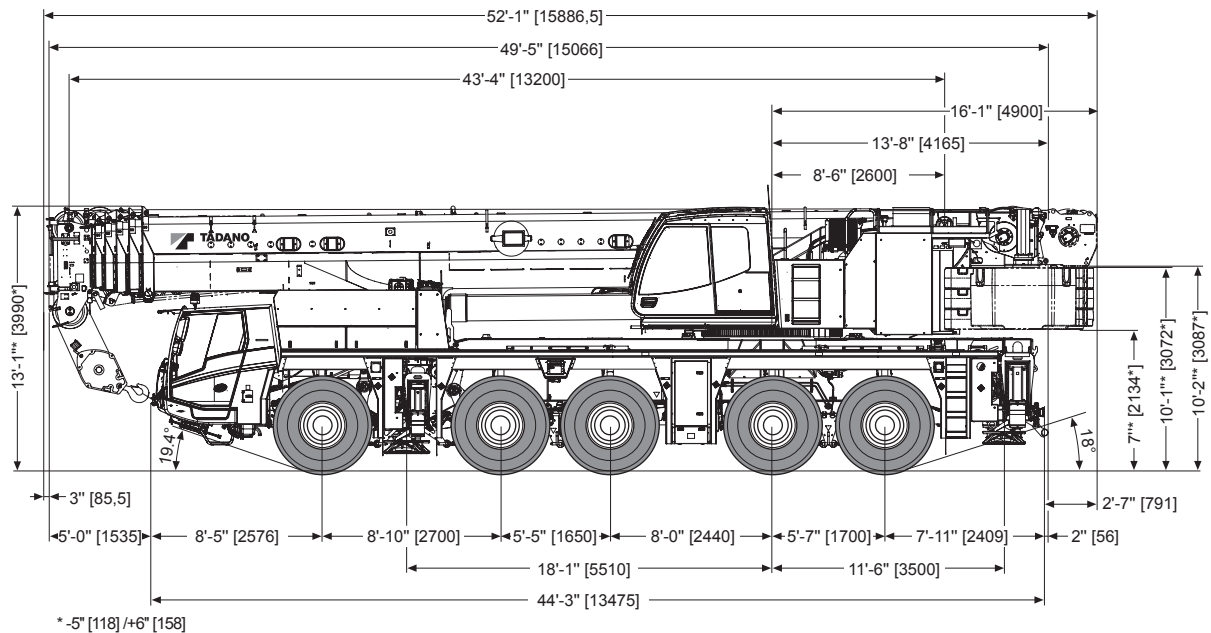

Axle weight distribution chart / Distribución de pesos por ejes

	Axle Eje	1	2	3	4	5	Dolly	Total weight Peso total
	Tires 525/80 R 25 (20.50 R 25) [lbs]		19,973	19,967	22,590	22,844	22,687	26,164

Boom in dolly, 35.6 ft behind boom pivot point	Total [lbs]	Axle 1 [lbs]	Axle 2 [lbs]	Axle 3 [lbs]	Axle 4 [lbs]	Axle 5 [lbs]	Dolly [lbs]
Base machine with equipment for USA, 16.00 R 25 tires, no counterweight, no fuel, no driver	124,532	18,071	18,081	21,588	21,861	21,891	23,225
* Fuel in carrier	992	92	91	274	268	268	
* Fuel in superstructure	441	46	46	118	115	115	
* Driver in carrier	198	150	148	-34	-33	-33	
* 11.0 ton [10.0 t]** headache ball (in transport position)							
35.3 ton [32.0 t]** (1 sheave) hook block (boom head)							
88.2 ton [80.0 t]** 3 sheaves hook block (boom head)							
43.3 ft / 63 ft Mechanical offset boom extensions	3,539	188	186	154	151	151	2,710
* 43.3 ft / 63 ft Hydraulic boom extensions	4,044	165	163	136	132	132	3,316
* Auxiliary winch with cable	3,043	1,288	1,275	163	159	159	
* Auxiliary boom point sheave (single top)	187	-9	-9	-8	-7	-7	229
* 2 nd oil cooler	101	7	7	30	29	29	
* 20.50 R 25 tires in lieu of 16.00 R 25	1,036	207	207	207	207	207	
Eddy-current brake	827	128	127	194	189	189	
* Towing attachment							
Tool box at rear	154	-66	-66	97	95	95	

* Basic configuration, marked items are included ** Metric

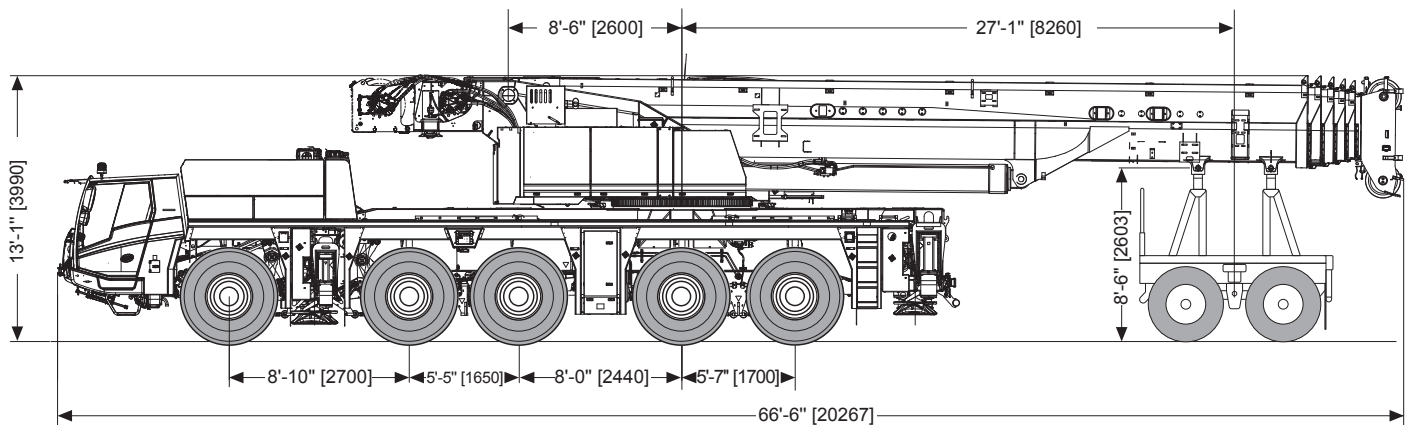

Counterweight versions / Variaciones de contrapeso

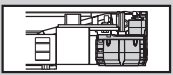
 Counterweight Contrapeso	1x	2x	1x	1x	1x
	①	②	③	④	⑤
[lbs]	26,455	15,432	26,455	22,487	3,968

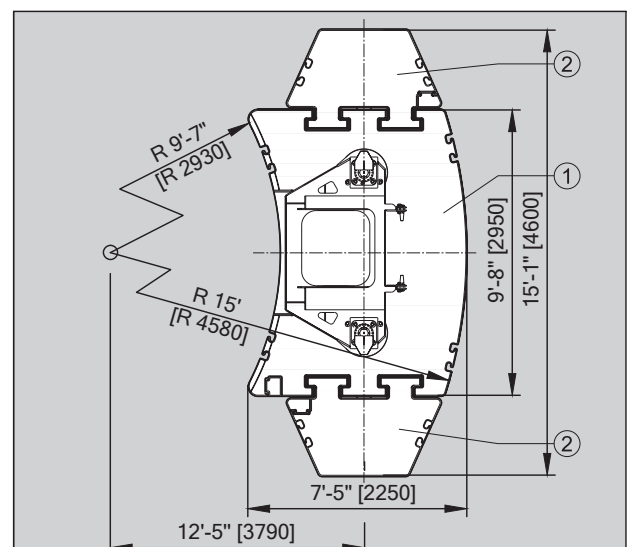
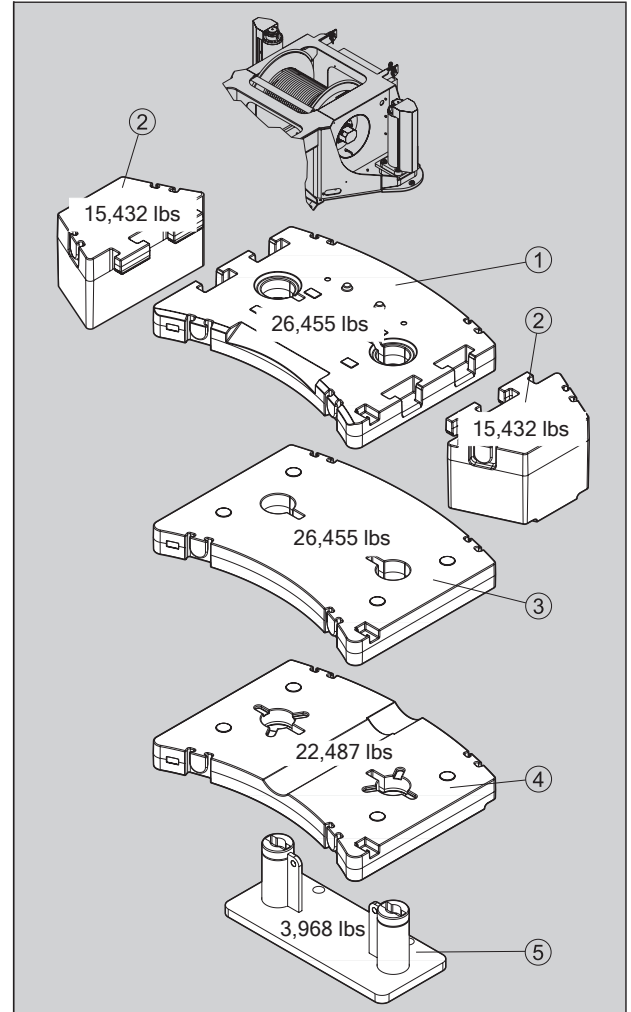
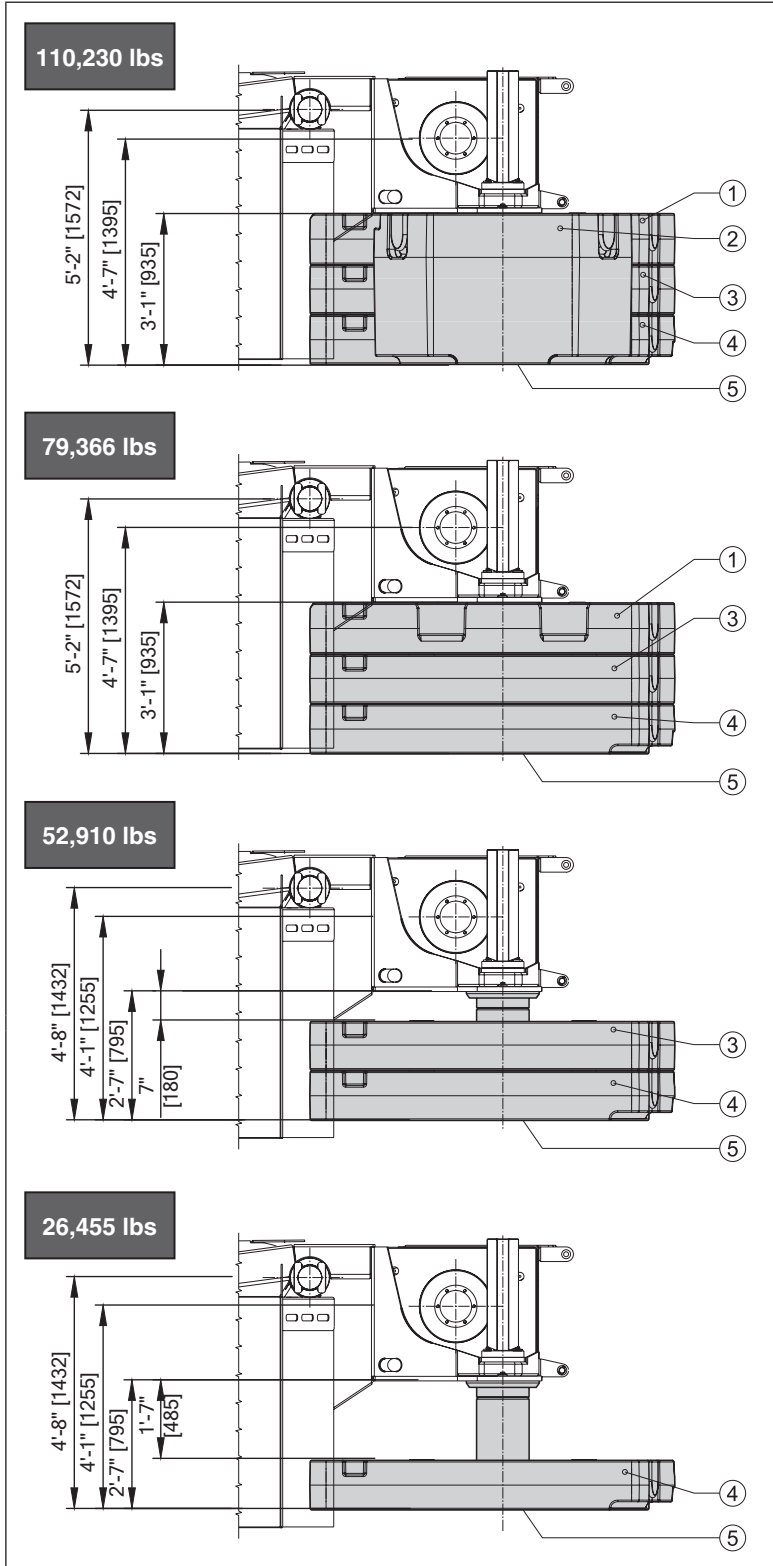



Frame Torsion-resistant, welded construction made from high strength, fine grained steel. Central lubricating system.

Outriggers 4 point, telescopic hydraulic outriggers, incl. automatic length detection and controls on both sides of carrier and in superstructure cab. Outrigger base 27'-3" (8.3 m) {18'-4" (5.6 m) mid extension} x 29'-8" (9.01 m).

Carrier engine Mercedes-Benz 6 cylinder model OM 471 LA (EPA Tier 4f), water-cooled diesel engine. Rated at 530 HP (390 kW) at 1,700 rpm. Torque 1,814 ft-lbs (2,460 Nm / 251 kpm) at 1,300 rpm. Engine rating according to ECE R 120. Fuel tank 158.5 gal (600 l). DEF tank 10.83 gal (40 l).

Transmission ZF-AS-Tronic 16 AS 2531 mechanical transmission with electro-pneumatically operated dry-type clutch and automatic gear shifting with 12 forward gears and 2 reverse gears.

Transfer Case Two stage.

Drive 10 x 8 (10 x 6 optional*)

Axles

- 1st axle: steered, driven (*not driven), with differential lock, transverse.
- 2nd axle: steered, driven, shiftable, with differential lock, transverse.
- 3rd axle: steered, not driven.
- 4th axle: steered, driven, with differential lock, longitudinal and transverse.
- 5th axle: steered, driven, with differential lock, transverse.

Suspension Hydro-pneumatic with levelling adjustment.

Brake system Service brakes: dual circuit compressed air system with electronic wear indicator. Parking brake: spring loaded type acting on 2nd, 4th and 5th axles. Auxiliary brakes: Inarder and engine brake.

Tires (10) 445/95 R 25 (16.00 R 25), width 9'-10" (3.00 m).
(10) 525/80 R 25 (20.50 R 25), width 10'-6" (3.20 m).

Steering system ZF-Servoocom, dual circuit hydraulic steering with emergency steering pump, mechanical hydraulically-assisted steering of front two axles and automatic steering of the 3rd and 4th axle up to a travel speed of 15.5 mph (25 km/h) and of the 5th axle up to 31.1 mph (50 km/h).

Carrier cab Two man full width cab of composite (steel sheet metal and fibre-glass) structure, with safety glass, central locking system, air-cushioned seats, driver's seat offering various adjustment options, with memory function and heater, engine dependent water heater, air conditioning, Bluetooth hands-free equipment, multifunction display, rear view camera, radio/CD player with USB port, control and operating elements for driving operation, Cruise Control and hill braking feature functions.

Electrical system 24 volt DC system, 2 batteries, outrigger area lighting, acoustic back-up alarm, lighting system with Bi halogen headlights; LED, daytime running light; LED, foglights, CAN bus system.

Optional Equipment (at extra charge)

Towing attachment, engine independent additional heater with engine pre-heat, ABS, 525/80 R 25 (20.50 R 25) tires, spare wheel and tire, special painting and lettering.

Further optional equipment available upon request.

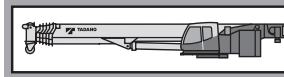

Frame Torsion resistant, all welded structure of high strength steel. Connected to carrier by single-row ball-bearing slewing ring with external gearing for 360° continuous rotation. Central lubricating system.

Superstructure engine Mercedes-Benz 4 cylinder model OM 934 LA (EPA Tier 4f), water-cooled, diesel engine. Rated at 175 HP (129 kW) at 2,200 rpm. Torque 553 ft-lbs (750 Nm / 76 kpm) at 1,200 - 1,600 rpm. Engine rating according to ECE R 120. Fuel tank 66 gal (250 l). DEF tank 2.64 gal (10 l).

Hydraulic system Three circuit diesel hydraulic system with 1 power controlled axial piston twin pump (hydraulically adjustable) with accumulative power control and 1 axial piston pump, oil cooler.

Controls Electrical, 2 joy-stick levers for simultaneous operation of crane motions.

Telescopic boom 6 sections, made of high tensile, fine-grained steel, consisting of 1 base section and 5 telescoping sections extended by means of a single telescopic cylinder. All telescope sections extendable under partial load. 43.3 ft (13.2 m) to 196.9 ft (60.0 m) long. Boom head with 7 sheaves

Derricking system 1 double acting hydraulic cylinder with integral brake and holding valve.

Main winch Axial piston motor, winch drum with integrated planetary reduction and hydraulically controlled spring loaded multiple disc brake and integrated free rotation (no sagging of load when hoisting). Hoist cable with 'Super-Stop' easy reeving system.

Slewing system Axial piston constant motor, three-stage planetary gear with service and parking brake. Open hydraulic circuit with wearless, dynamic free slewing function. Speed infinitely variable from 0 to 1.2 rpm.

Counterweight Total 110,230 lbs divisible, assembled and disassembled by hydraulic cylinders controlled from superstructure cab.

Superstructure cab Spacious crane cab in steel / plastic design with laterally extended tread plate, safety glass windows with tinted panes, tilting working place with adjustable, hydraulically damped driver's seat with heating, engine-fed and autonomous water heating (with engine pre-heating), air conditioning, radio/CD player with MP3/USB/SD Card port and Bluetooth handsfree equipment, control and operating elements for crane operation, outrigger actuation and carrier engine features

Electrical system 24 volt DC system, 2 batteries. 1 working floodlight on base boom, 2 integrated in crane cab.

Safety devices 'Lift Adjuster', load moment limiter (LMB) with pilot lamp in several colors incl. asymmetric outrigger base, anemometer, slewing area and working limitation with 'Slow-Stop' feature, hoist limit switch, lower limit switch, drum turn indicator, safety valves protect against pipe and hose ruptures.

Optional Equipment (at extra charge)

Boom extensions 36.1 ft to 114.8 ft, offsets 0°, 20° and 40° or hydraulically 0°- 40° (15.4 ft integrated heavy duty jib, boom extensions HTLJ 34 ft to 74.8 ft (hydraulically offsets and telescopic 0° - 60°), selection of hook blocks 11.0 t - 176.4 t, auxiliary winch (same as main winch), special painting and lettering, outrigger load display.

Further optional equipment available upon request.

Equipo

Chasis portante Construcción de acero de alta resistencia soldado, resistente a la torsión y a la flexión. Sistema de engrase central.

Estabilizadores Estabilizadores hidráulicos de 4 puntos incl. detección de longitud automática y posibilidad de manejo desde ambos lados del chasis portante y desde la cabina de la grúa. Extensión de los estabilizadores: 8,3 m (y 5,6 m) x 9,01 m.

Motor Mercedes Benz modelo OM 471 LA (EPA Tier 4f), 6 cilindros, diesel, refrigerado por agua. Nominal 390 kW (530 CV) a 1700 min⁻¹. Par 2460 Nm (251 kpm) a 1300 min⁻¹. Potencia del motor según ECE R 120. Depósito de combustible de 600 l. Depósito AdBlue 40 l.

Transmisión Transmisión mecánica tipo ZF-AS Tronic modelo 16 AS 2531 con accionamiento electro - neumático embrague en seco y cambio automático 12 marchas delanteras y 2 marchas traseras.

Transmisión Caja de distribución (transfer) con 2 relaciones de velocidad.

Tracción 10 x 8 (10 x 6 como opción*)

Ejes

- 1º eje: de dirección, accionado (*no accionado), con bloqueo diferencial transversal.
- 2º eje: de dirección, accionado, conectar según necesidad, con bloqueo diferencial transversal.
- 3º eje: de dirección, no accionado.
- 4º eje: de dirección, accionado, con bloqueo diferencial longitudinal y transversal.
- 5º eje: de dirección, accionado, con bloqueo diferencial transversal.

Suspensión Suspensión hidroneumática con regulación de nivel.

Frenos Sistema de frenos de disco neumático de doble circuito con indicador electrónico de desgaste. Freno de estacionamiento como freno de acumuladores a resorte accionando en los ejes 2, 4 y 5. Intarder y freno de motor como freno continuo.

Neumáticos (10) 445 / 95 R 25 (16.00 R 25), (ancho 3.00 m).
(10) 525 / 80 R 25 (20.50 R 25), (ancho 3.20 m).

Dirección Hidráulica ZF Servocom de doble circuito. Bomba hidráulica de emergencia accionada por la transmisión. Dirección mecánica al 1o y 2o eje y direccionable al 3o y 4o eje hasta una velocidad de 25 km/h y al 5o eje hasta una velocidad de conducción de 50 km/h.

Cabina Cabina de conductor frontal para dos personas construida en material compuesto de chapa de acero y plástico, acristalamiento de seguridad, bloqueo central, asientos neumáticos, asiento del conductor regulable en múltiples posiciones con función memoria y calefactable, calefacción por agua dependiente del motor, climatizador, dispositivo manos libres con Bluetooth, display multifunción, cámara de marcha atrás, Radio/Reproductor CD con toma USB, elementos de control y mando para el modo de conducción, Regulador de velocidad, sistema automático de frenado.

Sistema eléctrico 24 voltios de corriente continua, 2 baterías, iluminación de la zona de apoyo, alarma acústica para indicar la marcha atrás, sistema de luces con faros bihalógenos, luz LED de marcha diurna, faro LED antiniebla, sistema de bus CAN.

Equipo adicional (con suplemento de precio) Embrague de remolque, calefacción adicional con precalefacción del motor, Sistema anti bloqueo ABS, neumáticos 445/95 R 25 (16.00 R 25), 525/80 R 25 (20.5 R 25), rueda de repuesto, pintura especial y rotulación.

Otros equipamientos sobre pedido.

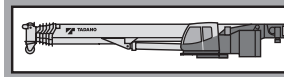

Superestructura Construida en aceros soldados, resistente a la torsión. Corona de giro con rodamiento de una fila de bolas con dientes externos para giro continuo a 360°. Sistema de engrase central.

Motor Mercedes Benz modelo OM 934 LA (EPA Tier 4f), 4 cilindros, diesel, refrigerado por agua. Las revoluciones aumentan de forma gradual accionando el acelerador. Nominal 129 kW (175 CV) a 2200 min⁻¹. Par 750 Nm (76 kpm) a 1200 - 1600 min⁻¹. Potencia del motor según ECE R 120. Depósito de combustible de 250 l. Depósito AdBlue 10 l.

Sistema hidráulico Dieselhidráulico con sistema hidráulico de 3 circuitos, 1 bomba doble de pistones axiales de caudal variable (hidráulicamente regulable) con regulación a caudal total y 1 bomba de pistones axiales, enfriador de aceite.

Mandos 2 palancas de control de tipo joy-stick para movimientos simultáneos de la grúa (4 direcciones), asistidos eléctricamente.

Pluma telescópica 6 secciones, un tramo base y 5 telescópicos de acero de alta resistencia soldado, 1 cilindro hidráulico, los tramos se pueden telescopar hidráulicamente bajo carga. Longitud de 13,2 m a 60,0 m. Cabeza de pluma con 7 poleas.

Elevación de pluma Mediante un cilindro hidráulico de doble efecto con válvula de retención integrada.

Cabrestante principal Motor hidráulico de pistones axiales y caudal fijo. Tambor del cabrestante con reducción planetaria y frenos de disco múltiples accionados, con sistema libre de elevación. Cable de elevación con sistema fácil de guiado y 'Super-Stop'.

Sistema de giro Motor de cilindrada constante de émbolos axiales, engranaje planetario de tres etapas con freno de servicio y estacionamiento. Circuito hidráulico abierto con desbloqueo del mecanismo giratorio dinámico sin desgaste, Velocidad de giro gradual de 0 a 1,2 min⁻¹.

Contrapeso Peso total 50 t divisible, se acciona desde la cabina de la grúa.











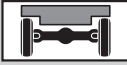
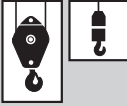

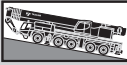
Cabina de la grúa Amplia cabina de grúa construida en chapa de acero y plástico con chapa pisadera lateral extensible, acristalamiento de seguridad coloreado, puesto de trabajo rebatible con asiento de conductor regulable amortiguado hidráulicamente con calefacción, calefacción por agua dependiente e independiente del motor (con precalentamiento del motor), climatizador, Radio/Reproductor CD con toma para MP3/USB/ tarjeta SD y dispositivo manos libres con Bluetooth, elementos de control y mando para el servicio de la grúa, accionamiento de estabilizadores y funciones chasis-motor





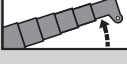

Sistema eléctrico 24 voltios de corriente continua, 2 baterías. 1 faro de trabajo en pluma base, 2 integrados en la cabina de grúa.

Dispositivos de seguridad "Lift Adjuster", limitador del momento de carga (LMC) con luz de señalización tipo semáforo, incl. distancia entre apoyos asimétrica, anemómetro, limitación de la zona de giro y del área de trabajo con función "Slow Stop", interruptor de fin de carrera, interruptor de fin de carrera del torno, indicador de giros del torno de cable. Válvulas de retención en los cilindros hidráulicos

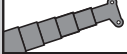
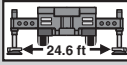
Equipo adicional (con suplemento de precio)
Plumín de 11,8 m a 35,8 m regulable de 0°, 20° y 40° (o hidráulicamente 0° a 40°), plumín de carga pesada de 5,6 m, plumín HTLJ de 8,5 m a 21 m (hidráulicamente regulable y telescopable 0° 60°), gancho de 10 a 160 t, 2º cabrestante (similar a cabrestante principal), pintura especial y rotulación, control carga (gatos de apoyo).

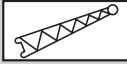
Otros equipamientos sobre pedido.

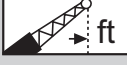
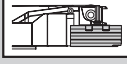
 445/95 R 25 (16.00 R 25)	Tires / Size Neumáticos / Tamaño de ruedas
	Axle load Carga por eje
	Hook block / Swivel hook Gancho / Gancho de bola
V+ 	Carrier speeds Velocidades del chasis
	Transmission / Gear Transmisión / Marchas
	Gradeability Superacion de pendientes
	Off road Todo terreno
	On road En carretera
V+ 	Superstructure speeds Velocidades de la superestructura
	Main winch Cabrestante principal
	Auxiliary winch 2° cabrestante
	Slewing system Sistema de giro
	Slewing system hydraulically locked Sistema de giro embulonamiento hidráulico
	Derricking system Elevación de pluma
	Boom telescoping Telescopaje de pluma

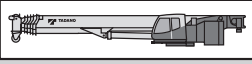
	Telescopic boom Pluma telescópica
 24.6 ft	Outriggers Estabilizadores
110,230 lbs	Counterweight Contrapeso
 ft	Radius Radio
	Boom extension Plumin
 HYDRO	Boom extension hydraulically Plumin hidráulicamente
	Boom extension HTLJ Plumin HTLJ
 ft	Radius Radio
	Counterweight versions Variaciones de contrapeso
	Carrier chasis
	Superstructure superestructura
SAE	The data are for basic information only and the operator's manual must be consulted before operating this crane. All data and performances refer to the standard crane. The addition of optional and other equipment may affect the performance of the crane. Los datos sirven solamente para su información. Hay que leer las instrucciones para el uso antes de la puesta en servicio de la máquina. Todos los datos mencionados en las presentes tablas rigen para los modelos standard. Cualquier modificación del equipo montado puede dar lugar a modificaciones de aquellos valores.

Notes / Notas

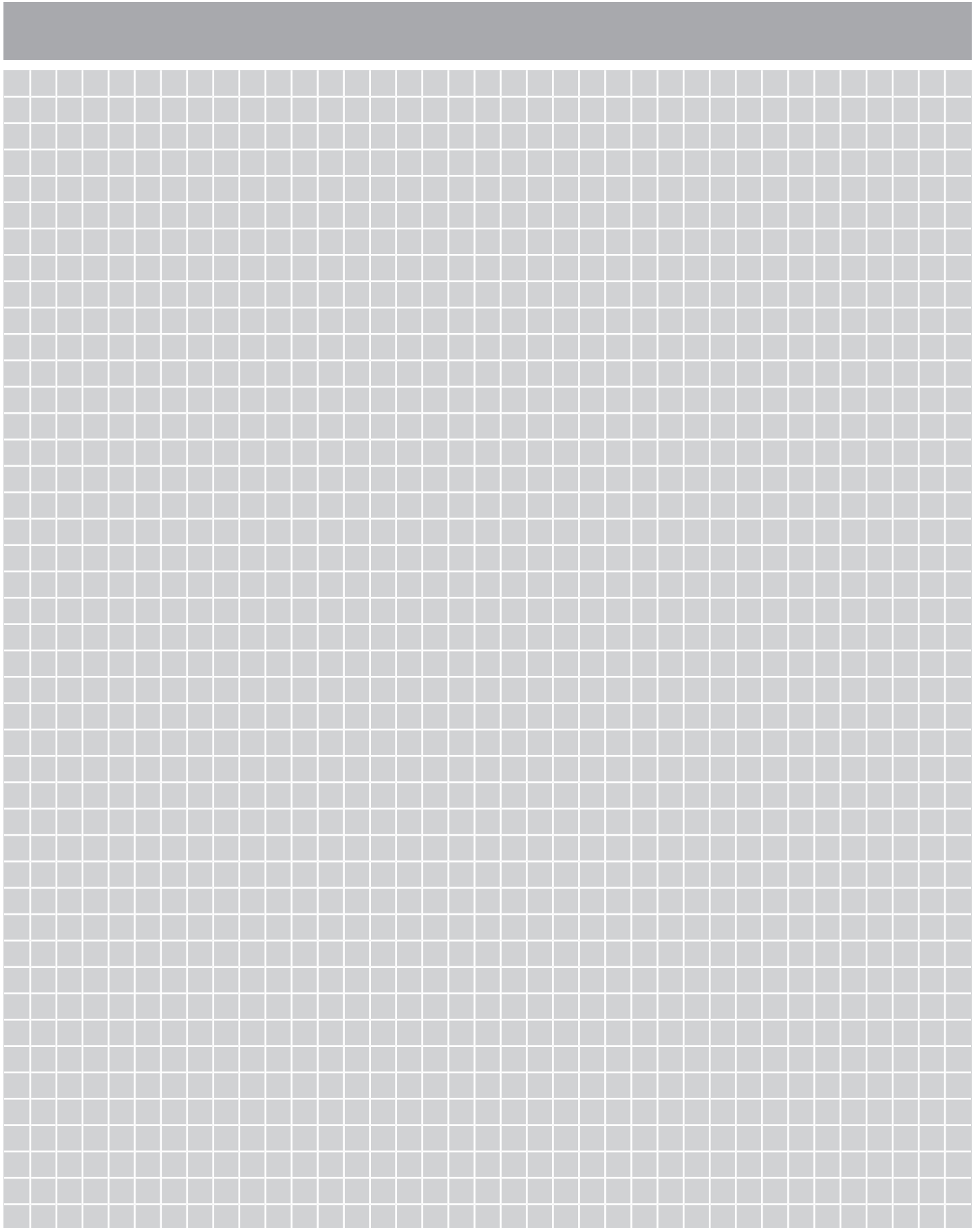

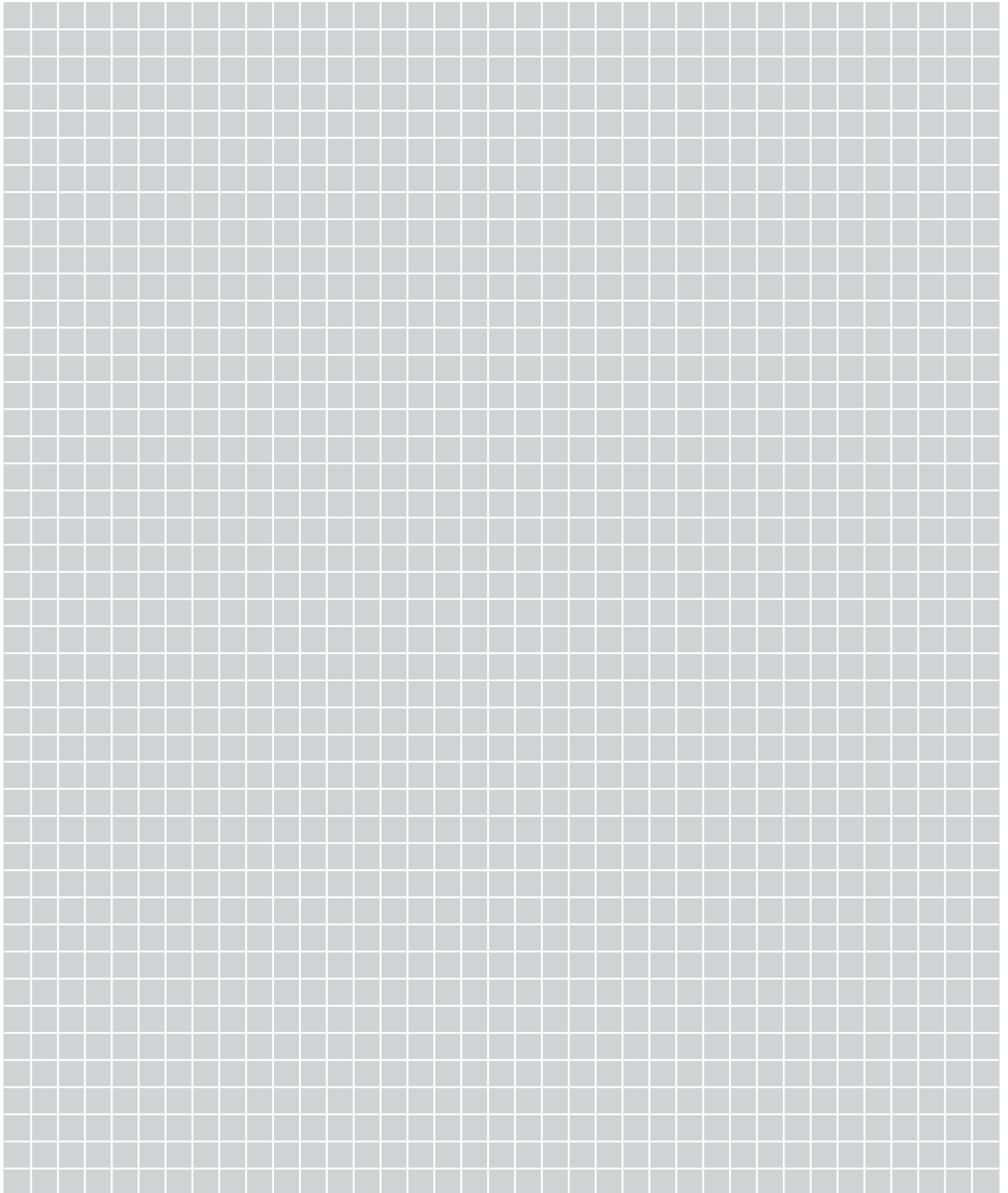



TADANO AMERICA Corporation

4242 West Greens Road, Houston, TX 77066

Phone: 281-869-0030 Fax: 281-869-0040

www.tadanoamerica.com E-mail: tac.sales@tadano.com

Parts Hotline: 281-869-0033 Service Hotline: 281-869-5925