

# SR5719E

## ELECTRIC COMPACT ROUGH TERRAIN TELEHANDLER



- Zero emission electric compact rough terrain telehandler with lithium-ion batteries
- Full-time 4-wheel drive
- Fully enclosed cab
- Power assisted steering
- Proportional joystick
- Simple to operate & maintain



**snorkel**<sup>™</sup>  
[www.snorkellifts.com](http://www.snorkellifts.com)

# ELECTRIC COMPACT ROUGH TERRAIN TELEHANDLER

# SR5719E

## CAPABILITIES SR5719E\*

Max. lift capacity	2,600kg
Max. lift height (A)	5.79m
Max. forward reach	3.1m

## DIMENSIONS

Overall width (B)	1.89m
Stowed height (C)	1.93m
Length to fork face (D)**	4.19m
Wheelbase	2.5m
Ground clearance	220mm

## PERFORMANCE

Max. drive speed	12km/h
Raise/lower time	6.9/5 sec
Hydraulic flow (per minute)	80L
Hydraulic pressure	230bar
Hydraulic oil capacity	70L
Outside turning radius	3.25m
Tires	12 x 16.5

## POWER

Power source	Lithium-ion 80V 32kWh batteries
Operating temperature	(-)20°C to (+)45°C
Charger	on-board, single phase

## WEIGHT

Weight	4,800kg
--------	---------

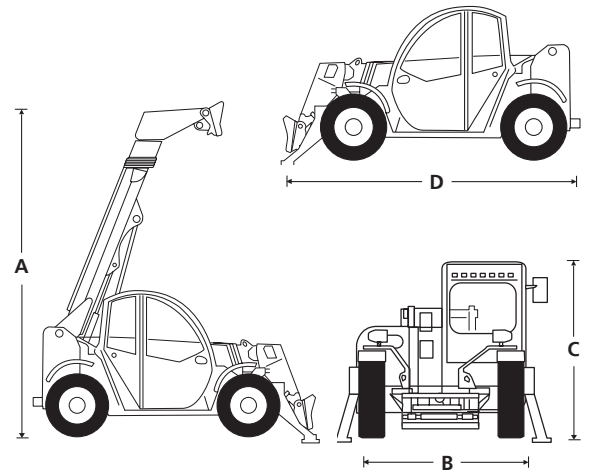

## LOAD CHART

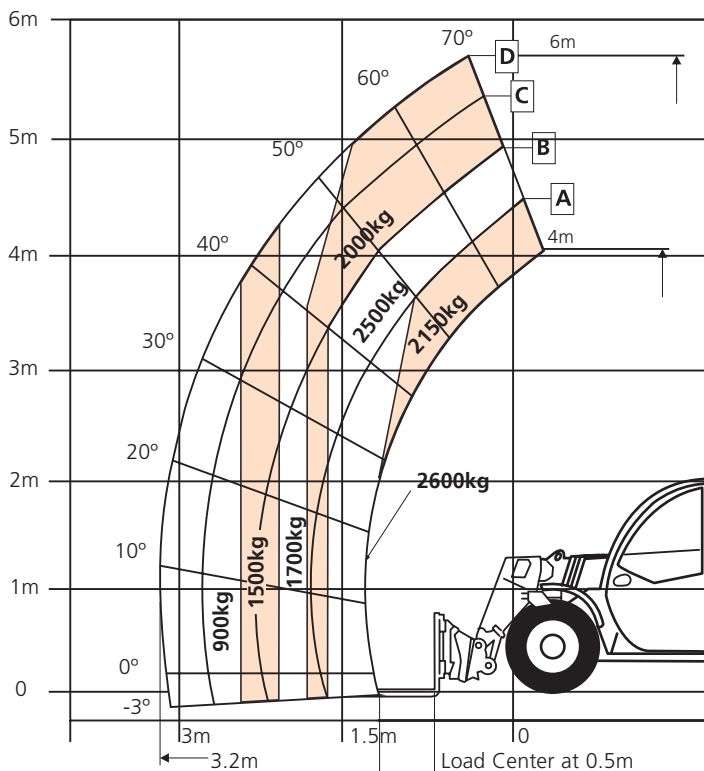

## STANDARD FEATURES

- Lithium-ion batteries
- Easy access to components for servicing
- Full-time 4-wheel drive
- 4-wheel steer
- Selectable front, crab & coordinated steering modes
- Auxiliary hydraulic circuit on the boom
- Variable speed hydrostatic drive
- Fully enclosed cab with heat
- Proportional joystick
- Illuminated gauge and switch panels
- Color LCD display with machine & engine diagnostics
- Adjustable suspension seat
- LED road lights (2)
- LED work lights on boom (2)
- 2000 charging cycles/2 year \*\*\* lithium battery warranty
- 2 year parts & labor, 5 year structural warranty
- ANSI compliant

## OPTIONS

- Special paint colors
- Multiple options for carriages, tires and fork tines
- Cold weather synthetic oil
- Swivel hook
- Hydraulic tank heater
- Universal skidsteer attachment
- External three-phase fast charger



www.snorkellifts.com

P.O. Box 1160  
St. Joseph, MO 64502-1160, USA  
Tel: 1 (785) 989-3000  
Toll-free: 1 (800) 255-0317  
Fax: 1 (785) 989-3070  
Email: sales.usa@snorkellifts.com