

QUALITY CHANGES THE WORLD

PRODUCT  
SPECIFICATIONS



# STC1100T7

SANY TRUCK CRANE  
110T LIFTING CAPACITY



110 t



73.2 m



4027.8 kN·m

[www.sanyglobal.com](http://www.sanyglobal.com)

V1.0

Courtesy of CraneMarket.com

### Excellent lifting capacity

7-section oval-shaped large cross-section boom, with full-extension length of 73.2 m; standard 17.5 m jib, and optional 9.5 m extension, enabling a maximum lifting height of 100.2 m;  
 8.1 m horizontal outrigger span, 38.5 t counterweight which can be moved backward by 550mm, providing the highest lifting capacity in the industry;  
 Maximum lifting moment of basic boom of 4027.8 kN · m (68.5 t\*6m), maximum lifting capacity of full-extension boom of 7.7 t, and boom lifting radius of 64m.

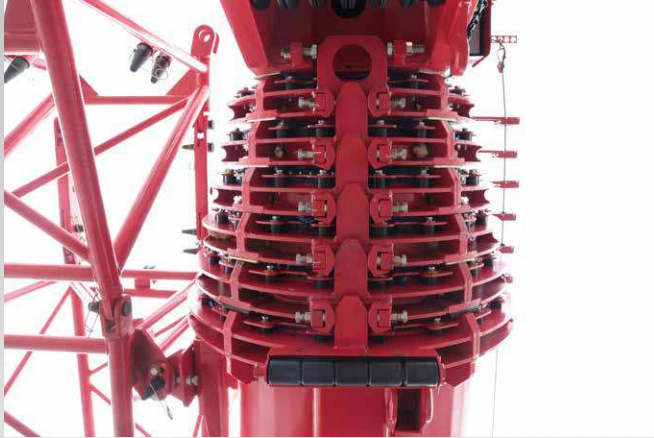

### Superstrong chassis performance

WEICHAI WP12 series high torque engine, Fast 12-speed transmission with synchronizer of high load and high torque, axles 1, 2 and 5 for steering and axles 3, 4 and 5 for driving, maximum travel speed of 90km/h;  
 Four 385/95R25 tires for front axle, and ten 325/95R24 tires for rear axle, traveling with 27.5 t counterweight allowed, and enough space available for outrigger pad\*;  
 450L large-capacity fuel tank, improving the range to empty tank by 30%. Upon traveling with 9.3 t counterweight, the 9.3 t counterweight shall be placed in the front and secured by four bolts.

### Energy-saving hydraulic system

Brand-new electric proportional dual-pump intelligent flow distribution system, which allows for independent luffing and oil confluence upon boom extension, improving the combined action control capability by more than 50%;  
 Electronic double slewing system, which enables no impact upon start/stop, and has a minimum stable slewing speed of 0.08° / s; double reducer configuration, making slewing at large boom length and large radius more powerful;  
 Innovated telescopic system of high efficiency and energy saving, with efficiency increased by 50% and energy consumption reduced by more than 15%;  
 Innovative automatic luffing compensation technology, enabling stable and efficient luffing under all load conditions.

## SANY TRUCK CRANE STC1100T7 / 110T LIFTING CAPACITY





## User-friendly control system

20° tiltable operator's cab; brand-new comfortable seat which can be moved forward and backward by 150mm and reclined by 140°; clear front field of view, allowing for lifting from far and near without any obstruction; Various user-friendly and comfortable facilities, including brand-new three-dimensional 7-vent air conditioning and ventilation system, front A/C control button, brand-new membrane switch, mobile phone support, cup holder, rear storage platform, etc.;

Intelligent power distribution and control: special battery compartment, and intelligent power distribution and control; Brand-new stairs with steps of increased inner width of 300mm and double cast aluminum alloy handrails provided on left and right sides of chassis, making boarding more comfortable and safer;

Access stairs provided on the right side of the turntable, providing a more convenient and fast maintenance passage for winch and boom;

Quick-union winch rope, improving the change efficiency of rope rate; quick-change double-head hook (anchor hook) and more heavy-duty slings, making stressing more uniform;

Wireless remote control system; single-person jib retraction and counterweight removal/installation.

Length of full-extension boom

73.2m

Max. gradeability

43%

Traveling with CW

27.5t



# Overall Dimensions

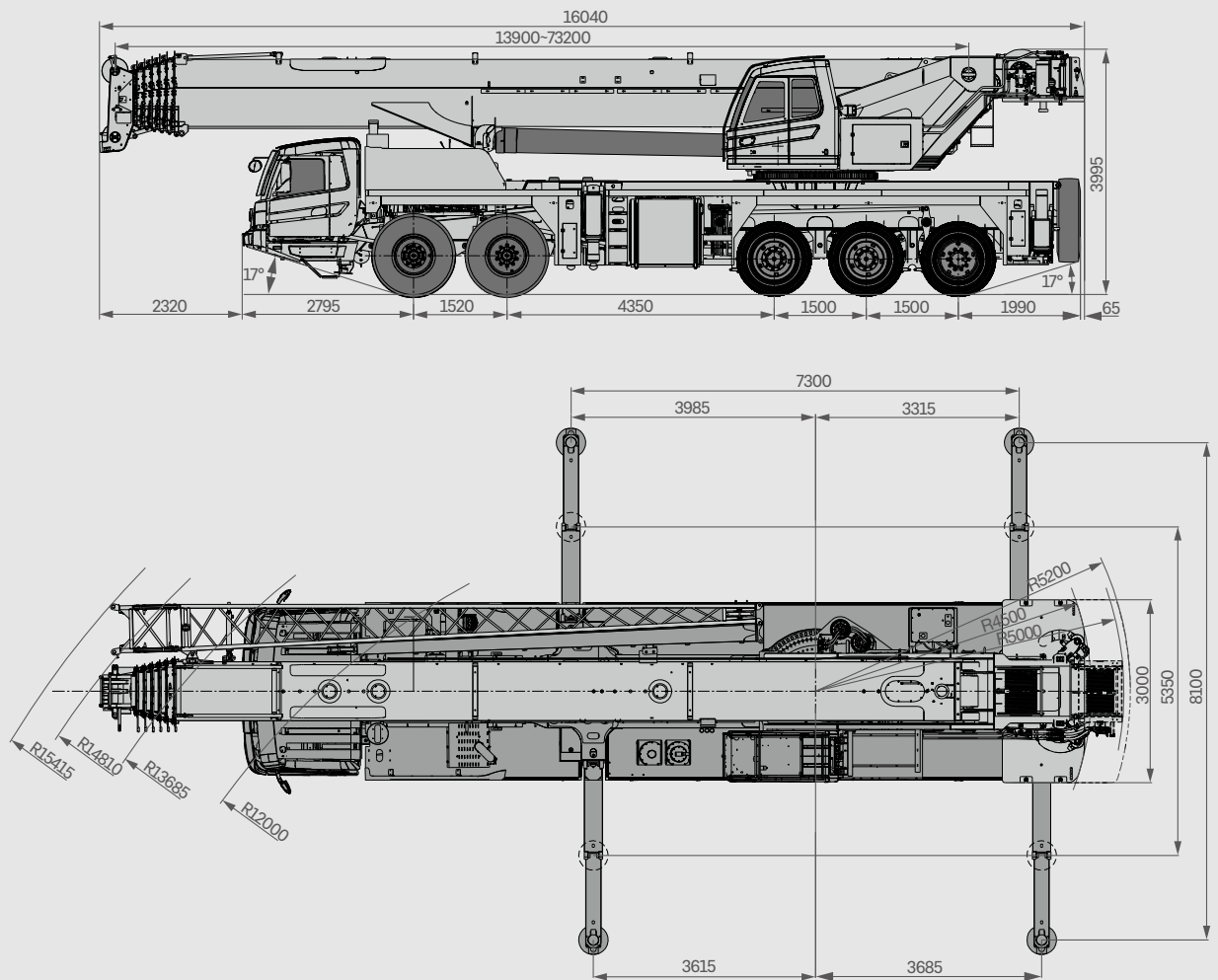

# Technical Specification

TYPE	ITEM	UNIT	PARAMETER	
DIMENSIONS	Overall length	mm	16040	
	Overall width	mm	3000	
	Overall height	mm	3995	
WEIGHT	Gross weight	kg	54600	
	Load	Axle 1 & 2	kg	24000
		Axle 3, 4 & 5	kg	30600
POWER	Engine model	-	WP12.430E50 (China V )	
	Max. power	kW/rpm	316/1900	
	Max. output torque	N.m/rpm	2060/1000-1400	
TRAVEL	Max. travel speed	km/h	90	
	Min. steering radius	m	12	
	Approach angle	°	>17	
	Departure angle	°	>17	
	Max. gradeability	%	43%	
	Fuel consumption per 100km	L	<48	
	Max. rated total lifting capacity	t	110	
MAIN PERFORMANCE	Turntable tail slewing radius	Fixed counterweight	m	4.5
		Including auxiliary winch (optional)	m	5.0
		Counterweight backward movement	m	5.2
	Max. lifting moment	Basic boom	kN.m	4027.8
		Full-extension boom	kN.m	1783.6
		Full-extension boom + jib	kN.m	830.7
		Full-extension boom + extension (optional) + jib	kN.m	533.3
	Outrigger span (transversal × longitudinal)	m	8.1(5.35) × 7.3	
	Boom length	Basic boom	m	13.9
		Full-extension boom	m	73.2
		Full-extension boom + jib	m	90.7
Full-extension boom + extension (optional) + jib		m	100.2	
OPERATION SPEED	Max. lifting speed of single rope of main winch (empty load)	m/min	135	
	Max. lifting speed of single rope of auxiliary winch (empty load)	m/min	135	
	Full extension/retraction time of boom	s	600/620	
	Full luffing up/down time of boom	s	60/90	
	Slewing speed	r/min	0-1.6	

# Technical Parameters



## Axle Load

Axle	1	2	3	4	5	Gross weight
Axle load /t	12	12	10.5	10.5	9.6	54.6
Remark	Excluding auxiliary winch and main/auxiliary hook					



## Hook

Load/t	Number of sheaves	Rope rate	Hook weight /kg
75 (double eye hook)	5	10	735
8	0	1	250
50*	4	8	595
80*	6	12	800
100* (double eye hook)	7	14	1030

\* Note: The configuration marked with “\*” is optional



## Operations

Item	Max. single rope lifting speed (empty load)	Rope diameter/length	Max. single line pull
Main winch	135m/min	20mm/325m	7.5t
Auxiliary winch	135m/min	20mm/210m	7.5t
Slewing speed	0-1.6r/min		
Full luffing up/down time of boom	60s/90s (0-80° )		
Full extension/retraction time of boom	600s/620s (13.9m-73.2m)		
Outrigger jack	Retraction	60s	
	Extension	50s	
Outrigger beam	Retraction	20s	
	Extension	30s	

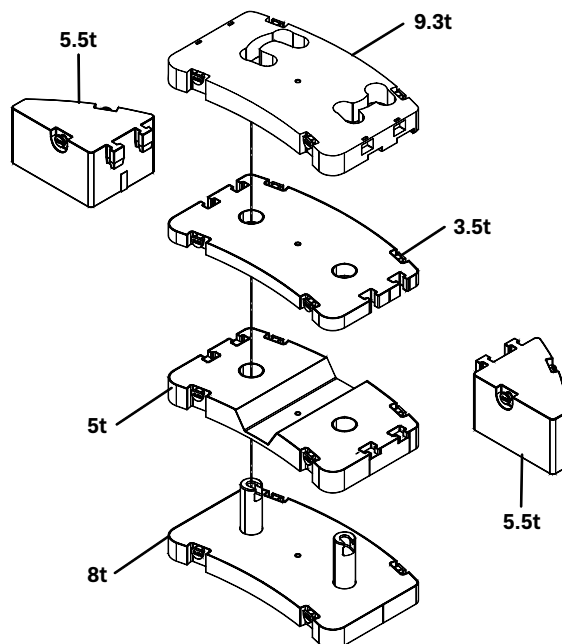

# Crane Introduction

superstructure

## Operator's cab

- Newly developed by Sany, it is tiltable within 0-20° and configured with electric telescopic step, adopts safety windscreen, corrosion-resistant steel plate, and is equipped with full-coverage softening interior decoration, panoramic skylight, adjustable seat, as well as enlarged air conditioner, three-dimensional 7-channel ventilation system and electric wiper, making operation more comfortable and easier. The 6-way angle adjustable 7-inch display is configured to realize the interaction of the console with the operation display system, so that all working condition data can be clear at a glance.

## Boom & telescoping system

- The boom consists of seven sections made of high-strength welded structural steel and has an oval cross section, with a full-extension length of 73.2 m; the jib is 17.5 m long, the extension of 9.5 m long is optional, the full-extension boom lifting height is 73.7 m, and the maximum lifting height in case of full-extension boom + jib + extension (optional) is 100.2 m. The highly reliable single bolt telescoping technology provides mechanical, electrical and hydraulic protections, and automatic telescoping and buffer technology is integrated, making operation easier.

## Hoist

- The pump and motor are designed with double variable speed regulation technology, providing high efficiency and low energy consumption.
- The normally closed winch brake is applied, and the winch balance valve is perfectly integrated with the unique anti-slip hook technology, making hoisting of weight more stable.
- Main hook of double-head design, with a weight of 735kg and a maximum lifting capacity of 75t; one auxiliary hook, with a weight of 250kg and a maximum lifting capacity of 8t. Rope of main winch: left-handed rope 20-35W × K7-1960L325m; Rope of optional auxiliary winch: left-handed wire rope 20-35W × K7-1960L210m.

## Luffing system

- The dead-weight luffing compensation technology is adopted, reducing the energy consumption and improving the luffing stability.
- Luffing angle: -1.5°~80°.

## Hydraulics

- The newly-developed electric proportional dual-pump intelligent flow distribution system allows for independent luffing and oil confluence upon boom extension, improving the combined action control capability by more than 50%.
- The imported load-sensitive double piston pump with high-precision flow control is adopted, reducing the energy loss by more than 30%.
- The electric main valve has such functions as flow compensation and load feedback control, enabling easier and stable control of single action and combined action.
- The winch is applied with the electronically controlled variable displacement motor, allowing for high working efficiency at high speed, and good stability and low noise at low speed; the max. speed of single rope of main and auxiliary winches is 135m/min.
- The integrated slewing buffer valve with free slipping is applied for the slewing system, providing stable slewing start and control and excellent micro-mobility.

## Slewing

- The brand-new electronic double slewing system has a slewing angle of 360° and the maximum slewing speed of 1.6r/min; the automatic load compensation technology ensures no impact upon start/stop, making the slewing more stable; the double reducer configuration makes slewing at large boom length and large radius more powerful.

## Control system

- Bus instrument: The bus system is integrated with intelligent control electrical system, which can control driving parameters whenever necessary to ensuring easy driving. In addition, it is configured with the engine fault indicator, thus ensuring convenient and quick maintenance and troubleshooting.
- An all-round safety protection system is provided, including 3-wrap rope protector and height limiter of hoisting winches, roll-over protection and angle limiter.
- Moment limiter: The highly-intelligent moment limiter is applied, ensuring fully-protected, accurate, stable and comfortable lifting operations.
- The basic interface of superstructure displays rich information including boom length, boom angle, working radius, rope rate, counterweight combination, engine speed, hook selection, etc., which are easy to understand and can quickly reflect the working condition of the vehicle.
- The fault self-diagnosis system is applied for testing the fault of the electrical system and hydraulic systems of superstructure as well as the chassis (major safety-related faults), engine and transmission, ensuring the reliable operation of the crane.

## Outrigger

- H-type layout, four point support, easy to operate, outrigger beam hydraulically telescoping, jack telescoping protected by two-way pilot controlled valve.

## Counterweight

- Counterweight 38.5 t, which can be moved backward by 550mm.
- Variable combinations: 38.5t, 29.2t, 27.5t, 24t, 19t, 18.2t, 14.7, 9.7.

## Safety equipment

- Moment limiter: The moment limiter calculation system is developed by using the mechanics analysis method based on the hoisting mechanical model, and the rated hoisting accuracy is controlled within ± 3% through online no-load calibration, enabling all-round protection for the hoisting operations; in case of overloading operations, the system will send an alarm automatically to provide safety guarantee for operations.
- Hydraulic balance valve, overflow valve, two-way hydraulic lock and other elements are provided for the hydraulic system, ensuring good stability and reliability of the hydraulic system.
- 3-wrap rope protector is provided for hoisting winches to prevent rollover of wire rope.
- Height limiter is mounted at tip of boom and jib to prevent over-hoisting of the wire rope.
- Length sensor, angle sensor and pressure sensor are adopted to provide rear-time operation status display, automatic stop of dangerous action, and buzzer alarm.
- Anemometer is equipped to monitor wind speed in real time to ensure hoisting safety.

# Crane Introduction

Carrier

## Driver's cab

- Independently developed by Sany in ergonomic design, it is of new all-steel and rubber sealing structure, enabling high damping and sealing performance. It is configured with outward opening doors on both sides, air-suspension driver seat and passenger's seat, three-point seat belt, adjustable steering wheel, wide-angle rearview mirror, comfortable driver seat headrest, antifogging fan, HVAC, 7-inch multimedia terminal, a complete set of controls and instruments, and a standard sleeper, creating a more comfortable, safe and user-friendly driving environment.

## Carrier frame

- The low front outrigger box + high-strength rectangular cross-section frame designed and manufactured by Sany is applied, which is heightened and widened, and compared with groove frame, boasts a rigidity of 30% higher and a greatly improved load bearing capacity.

## Engine

- Type: In-line, 6-cylinder, water-cooled, turbocharged & intercooled diesel engine.
- Emission standard: China VI.
- Fuel tank capacity: 450L.

## Transmission

- Transmission: A 12-speed manual transmission is applied, providing a wide speed ratio range, and allowing for both low-speed climbing and high-speed traveling.
- Drive shaft: The arrangement of drive shaft is optimized to provide a stable and reliable transmission. The force transmission is optimized by the provision of transverse tooth coupling drive shaft, enabling a higher transmission torque.

## Axle

- Axles 3, 4 and 5 are driving axles, and axles 1, 2 and 5 are steering axles, which are built in with bogie differential and inter-wheel differential; the axle housing is made through punching and welding, ensuring a stronger bearing capacity.

## Suspension system

- The front axle is applied with independent leaf spring suspension, and the intermediate and rear axles are applied with the swing-bracket leaf spring balanced suspension, which have been subjected to more than 100,000 fatigue tests, and optimized in performance parameters to ensure the strength and ride comfort.

## Steering

- Hydraulic power steering system is applied for axles 1, 2 and 5, which consists of large-flow steering gear and power steering fluid reservoir, greatly reducing steering resistance and making steering lighter.

## Tires

- 4\*385/95R25+10\*325/95R24.

## Wheel formula

- 10x6.

## Brake

- Air servo functions on all wheels with dual circuit system.
- Service brake: air servo, dual circuits; wedge brake and double air chambers functioning on front axles.
- Parking brake: functioning at axles 3 and 4 by spring in air chamber.
- Emergency brake: performed by accumulator.
- Assisting brake: exhaust brake, safety assured when driving down long slopes.

## Outrigger

- The outriggers apply the 4-point support structure with a span (Longitudinal × Transversal) of 7.3m × 8.1m, easy to operate and highly stable; the outriggers are made of fine grain high-strength steel plate, and the first section and second section are controlled fully hydraulically for extension and retraction. The outrigger vertical cylinder is adopted with bilateral pilot-controlled valve for safety protection.

## Optional equipment at extra fees

- 100t hook, 55t hook, auxiliary winch assembly, 9.5m boom extension, outrigger pad.



# Operating Range

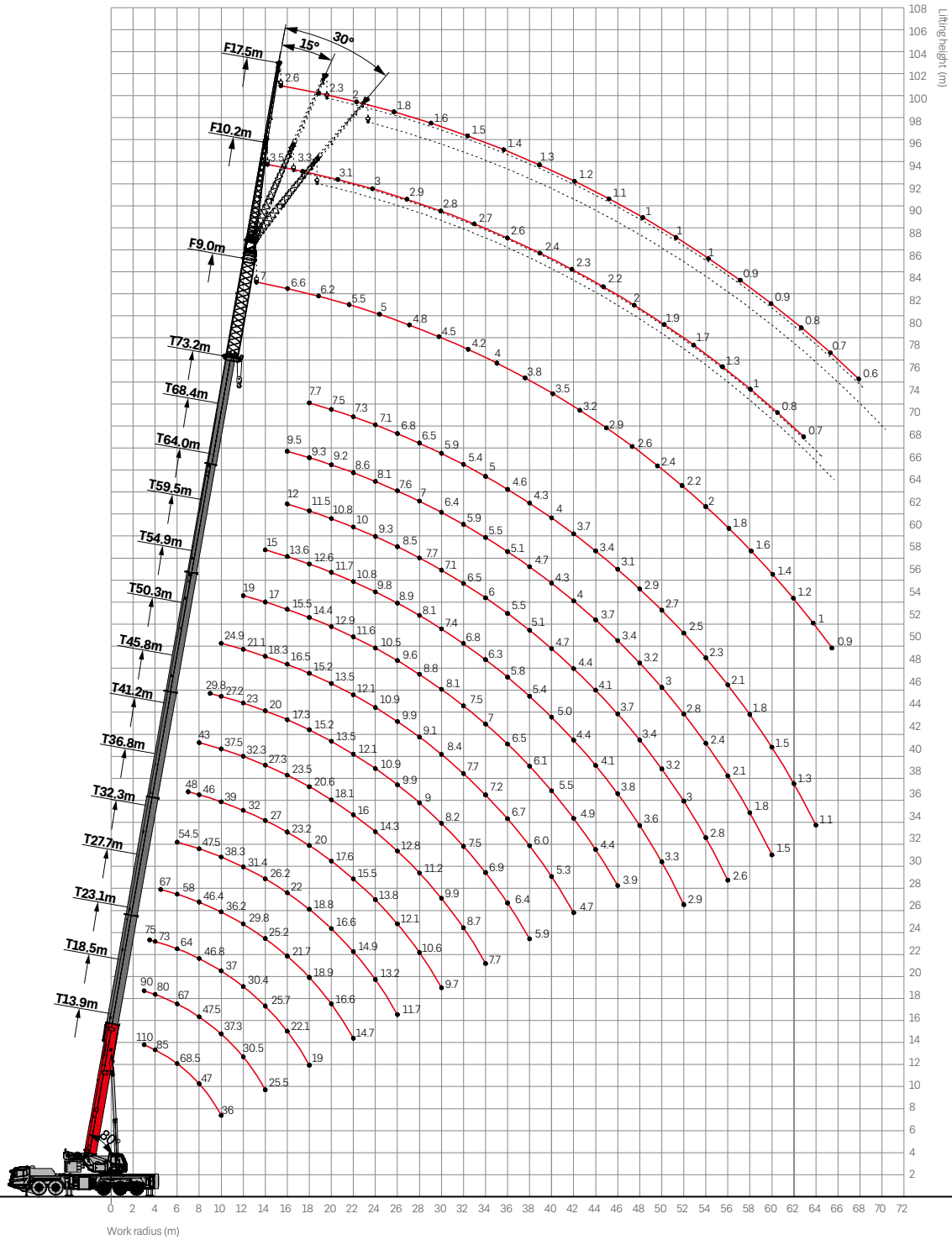

# Load Chart-Telescopic Boom



Unit: t

Radius (m)	13.9	18.5	23	27.6	32.1	36.7	41.2	45.7	50.3	54.9	59.4	63.9	68.4	73.2	Radius (m)
3	110.0*	90													3
3.5	92.0*	85	75												3.5
4	84	80	72.5												4
4.5	78	77	70.2	67											4.5
5	75	73	68.5	64											5
5.5	72	70	65	62											5.5
6	68.5	67	62	58	54.5										6
6.5	62	61	58.5	54.6	51.8										6.5
7	56	55	53.5	51.6	49.5	48									7
7.5	51	50.5	50	49	47.5	46.7									7.5
8	47	46.5	46.5	46.1	45.8	45.5	43								8
9	41	40.5	41.5	40.7	41.5	42	40	29.4							9
10	36	36	36.9	36.2	36.9	39	37.5	26.8	24.9						10
12		29.3	30	29.8	30.2	32	32.3	22.7	21.1	19					12
14		24.6	25.1	25.2	25.4	27	27.2	19.7	18.3	17	15				14
16			21.6	21.7	21.8	23.1	23.4	17	16.5	15.5	13.6	12	9.5		16
18			18.7	18.9	18.9	20.1	20.3	14.9	15.2	14.4	12.6	11.5	9.3	7.7	18
20				16.6	16.5	17.5	17.9	13.2	13.5	12.9	11.7	10.8	9.2	7.5	20
22				14.7	14.5	15.3	15.9	11.8	12.1	11.6	10.8	10	8.6	7.3	22
24					12.8	13.7	14.2	10.6	10.9	10.5	9.8	9.3	8.1	7.1	24
26					11.5	12.1	12.8	9.6	9.9	9.6	8.9	8.5	7.6	6.8	26
28						10.8	11.2	8.7	9.1	8.8	8.1	7.7	7	6.5	28
30						9.9	9.9	7.9	8.4	8.1	7.4	7.1	6.4	5.9	30
32							8.7	7.2	7.7	7.5	6.8	6.5	5.9	5.4	32
34							7.7	6.6	7.2	7	6.3	6	5.5	5	34
36								6.1	6.7	6.5	5.8	5.5	5.1	4.6	36
38								5.6	6	6.1	5.4	5.1	4.7	4.3	38
40									5.3	5.5	5	4.7	4.3	4	40
42									4.7	4.9	4.4	4.4	4	3.7	42
44										4.4	4.1	4.1	3.7	3.4	44
46										3.9	3.8	3.7	3.4	3.1	46
48											3.6	3.4	3.2	2.9	48
50											3.3	3.2	3	2.7	50
52											2.9	3	2.8	2.5	52
54												2.8	2.4	2.3	54
56												2.6	2.1	2.1	56
58													1.8	1.8	58
60													1.5	1.5	60
62														1.3	62
64														1.1	64
Telescoping status															
Rope rate	14	12	10	9	8	7	6	4	4	3	3	3	3	3	Rope rate

Remark: the ratings are given for load over rear and side.

# Load Chart-Telescopic Boom



Unit: t

Radius (m)	13.9	18.5	23	27.6	32.1	36.7	41.2	45.7	50.3	54.9	59.4	63.9	68.4	73.2	Radius (m)
3	110.0*	90.0													3
3.5	92.0*	85.0	75.0												3.5
4	84.0	80.0	72.5												4
4.5	78.0	77.0	70.2	67.0											4.5
5	75.0	73.0	68.5	64.0											5
5.5	72.0	70.0	65.0	62.0											5.5
6	67.0	66.0	62.0	58.0	54.5										6
6.5	60.0	59.7	58.5	54.6	51.8										6.5
7	53.5	53.5	53.5	51.6	49.5	48.0									7
7.5	49.5	49.0	50.0	49.0	47.5	46.7									7.5
8	46.0	45.0	46.5	46.1	45.8	45.5	43.0								8
9	40.0	39.2	41.5	40.7	41.5	42.0	40.0	29.4							9
10	35.0	34.5	36.9	36.2	36.9	39.0	37.5	26.8	24.9						10
12		28.0	29.8	29.8	29.8	32.0	32.3	22.7	21.1	19.0					12
14		23.0	24.8	24.2	24.5	25.2	26.5	19.7	18.3	17.0	15.0				14
16			21.3	21.0	20.8	21.5	21.7	17.0	16.5	15.5	13.6	12.0	9.5		16
18			17.9	17.7	18.1	18.6	18.8	14.9	15.2	14.4	12.6	11.5	9.3	7.7	18
20				15.0	15.4	16.3	15.7	13.2	13.5	12.9	11.7	10.8	9.2	7.5	20
22				13.3	13.5	13.8	13.3	11.8	12.1	11.6	10.8	10.0	8.6	7.3	22
24					12.2	11.9	11.3	10.6	10.9	10.5	9.8	9.3	8.1	7.1	24
26					10.7	10.3	9.7	9.6	9.6	9.6	8.9	8.5	7.6	6.8	26
28						9.0	8.4	8.3	8.3	8.6	8.1	7.7	7.0	6.5	28
30						7.9	7.3	7.1	7.2	7.4	7.0	7.1	6.4	5.9	30
32							6.3	6.1	6.2	6.4	6.5	6.3	5.9	5.4	32
34							5.6	5.5	5.4	5.6	5.9	5.8	5.5	5.0	34
36								4.9	5.0	4.8	5.1	5.4	5.0	4.6	36
38								4.5	4.4	4.2	4.5	4.8	4.4	4.3	38
40									4.0	3.9	3.9	4.2	3.8	3.8	40
42									3.7	3.6	3.6	3.7	3.2	3.3	42
44										3.2	3.3	3.2	2.8	2.8	44
46										2.9	3.0	2.8	2.3	2.4	46
48											2.7	2.4	2.0	2.0	48
50											2.4	2.1	1.6	1.6	50
52											2.0	1.8	1.3	1.3	52
54												1.5	1.0	1.0	54
56												1.2			56
Telescoping status															
Rope rate	14	12	10	9	8	7	6	4	4	3	3	3	3	3	Rope rate

Remark: the ratings are given for load over rear and side.

# Load Chart-Telescopic Boom



Unit: t

Radius (m)	13.9	18.5	23	27.6	32.1	36.7	41.2	45.7	50.3	54.9	59.4	63.9	68.4	73.2	Radius (m)
3	110*	90													3
3.5	92*	85	75												3.5
4	85	80	73												4
4.5	80	77	71	67											4.5
5	75	73	69	64											5
5.5	71	70	67	62											5.5
6	66	64.5	63.5	58	54.5										6
6.5	59	58.8	58.8	55	52.5										6.5
7	52	51.5	54	53	51	48									7
7.5	48	48	50	50	49.5	47									7.5
8	44.5	43.7	46.2	46.4	47	46	43								8
9	39	38	41.5	40.7	41.5	42	40	29.8							9
10	34.3	33.9	36.5	35.8	36.5	37	37	27.2	24.9						10
12		27.5	28.5	29	28.8	30	31	23	21.1	19					12
14		22.5	23.5	24.2	24	24.6	26.4	20	18.3	17	15				14
16			20	19.9	20.7	20.7	21.1	17.3	16.5	15.5	13.6	12	9.5		16
18			16.4	17.1	17.1	17.9	17.3	15.2	15.2	14.4	12.6	11.5	9.3	7.7	18
20				14.4	15.1	14.9	14.4	13.5	13.5	12.9	11.7	10.8	9.2	7.5	20
22				12.2	13	12.7	12.1	11.9	12	11.6	10.8	10	8.6	7.3	22
24					11.2	10.8	10.3	10.1	10.1	10.4	9.8	9.3	8.1	7.1	24
26					9.7	9.3	8.7	8.6	8.6	8.9	8.4	8.5	7.6	6.8	26
28						8	7.6	7.3	7.3	7.6	7.4	7.5	7	6.5	28
30						7	6.5	6.5	6.3	6.5	6.9	6.8	6.4	5.9	30
32							5.9	5.8	5.8	5.6	5.9	6.3	5.8	5.4	32
34							5.2	5.3	5.1	5	5.1	5.5	5	5	34
36								4.7	4.7	4.6	4.6	4.8	4	4.3	36
38								4.1	4.3	4.1	4.2	4.1	3.7	3.7	38
40									3.9	3.8	3.9	3.6	3.1	3.1	40
42									3.4	3.5	3.4	3.1	2.6	2.6	42
44										3.2	2.9	2.6	2.2	2.2	44
46										2.9	2.5	2.3	1.8	1.8	46
48											2.2	1.9	1.4	1.4	48
50											1.9	1.6	1.1	1.1	50
52											1.6	1.3	0.8	0.8	52
54												1			54
Telescoping status															
Rope rate	14	12	10	9	8	7	6	4	4	3	3	3	3	3	Rope rate

Remark: the ratings are given for load over rear and side.

# Load Chart-Jib



Unit: t

Boom angle (°)	73.2+10.2			73.2+17.5			73.2+9	73.2+9.5+10.2			73.2+9.5+17.5			Boom angle (°)
80	5.5	4	3.3	3.7	2.4	1.6	7	3.5	2.8	2.2	2.6	1.6	1.3	80
78	5.5	4	3.3	3.6	2.3	1.6	6.6	3.3	2.6	2	2.3	1.5	1.2	78
76	5.2	4	3.2	3.5	2.2	1.6	6.2	3.1	2.4	1.9	2	1.3	1.2	76
74	5	3.9	3.2	3.1	2.1	1.5	5.5	3	2.3	1.9	1.8	1.2	1.1	74
72	4.5	3.8	3.1	2.8	2	1.5	5	2.9	2.3	1.8	1.6	1.2	1.1	72
70	4.3	3.7	3.0	2.7	1.9	1.4	4.8	2.8	2	1.7	1.5	1.1	1.1	70
68	4.0	3.5	2.8	2.6	1.8	1.3	4.5	2.7	1.9	1.6	1.4	1.1	1	68
66	3.7	3.2	2.7	2.4	1.7	1.3	4.2	2.6	1.8	1.6	1.3	1	1	66
64	3.4	2.9	2.5	2.2	1.6	1.3	4	2.4	1.8	1.5	1.2	1	1	64
62	3.1	2.7	2.3	2.0	1.6	1.3	3.8	2.3	1.7	1.5	1.1	1	0.9	62
60	2.8	2.5	2.1	1.8	1.5	1.2	3.5	2.2	1.6	1.4	1	0.9	0.9	60
58	2.6	2.3	2.0	1.7	1.5	1.2	3.2	2	1.5	1.3	1	0.9	0.8	58
56	2.4	2.1	1.9	1.6	1.4	1.2	2.9	1.9	1.5	1.2	1	0.9	0.8	56
54	2.2	1.9	1.8	1.6	1.4	1.1	2.6	1.6	1.3	1.1	0.9	0.8	0.7	54
52	2.0	1.7	1.6	1.5	1.3	1.1	2.4	1.2	1.1	1	0.9	0.8	0.7	52
50	1.8	1.5	1.5	1.3	1.2	1.0	2.2	0.9	0.8	0.7	0.7	0.6	0.5	50
48	1.6	1.3	1.3	1.2	1.1	0.9	2	0.7	0.6	0.5	0.5			48
46	1.3	1.2	1.2	1.1	0.9	0.8	1.7	0.6	0.5					46
44	1.1	1.0	1.0	0.9	0.7	0.7	1.4							44
42	0.9	0.8	0.8	0.7	0.6		1.2							42
40	0.8	0.7	0.7	0.6			1							40
38	0.7	0.6					0.8							38
36							0.7							36
Rope rate	1													Rope rate
Hook weight (kg)	250													Hook weight (kg)



## SANY GROUP CRANE BU

SANY Mobile Crane Industrial Park, No.168 Jinzhou Avenue, Jinzhou Development Zone, Changsha City, Hunan Province, P.R. China Zip 410600

Consulting [sanycrane@sanygroup.com](mailto:sanycrane@sanygroup.com) (Crane BU) / [crd@sany.com.cn](mailto:crd@sany.com.cn) (IHQ)

After-sales Service 0086-400 6098 318

**Reminder:**

Any change in the technical parameters and configuration due to product modification or upgrade may occur without prior notice. The machine in the picture may include additional equipment. This brochure is for reference only, and goods in kind shall prevail.

Copyright at SANY. No part of this brochure may be copied or used for any purpose without written approval from SANY.

© Edited in October 2021

