



SCE600A

Crawler Crane

60 Tons Lifting Capacity

Quality Changes the World



Max. lifting moment: 222t·m
Max. boom length: 52m
Max. fixed jib combination: 43m+15.25m

The parameters and diagrams in the brochure is only for reference, which is subject to further update in real machine.

■ www.sany.com.cn

Courtesy of CraneMarket.com

Crawler Crane Series
SCE600A

| | | |
|-----|----------------------|---|
| P03 | Main Characteristics | <ul style="list-style-type: none">▪ Product Specification▪ Safety Device |
| P09 | Technical Parameters | <ul style="list-style-type: none">▪ Major Performance & Specifications▪ Outline Dimension▪ Transport Dimension▪ Transport Plan |
| P17 | Cofigurations | <ul style="list-style-type: none">▪ H Configuration▪ FJ Configuration |



SCE600A
SANY CRAWLER CRANE
60 TONS LIFTING CAPACITY

QUALITY CHANGES THE WORLD

Main Characteristics

- Page 04 Product Specification
- Page 07 Safety Device

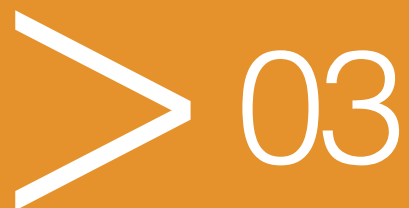

Product Specification



Engine

- Model: Cummins B6.7-C195 Diesel engine;
- Type: 4-stroke, water-cooled, vertical in-line 6 cylinders, direct injection, turbo-charger, intercooler, complied with European Off-way Stage V Emission Standard;
- Displacement: 6.7L;
- Rated power: 145kW/1800rpm;
- Operation power: 142kW/1800rpm;
- Max. Torque: 847N·m/1500rpm;
- Starter: 24V-7.8kW;
- Cooling system: pressurized water circulating system with temperature adjustable;
- Radiator: fin type aluminum plate core;
- Air cleaner: Dry type system with main filter element, safety element and resistance indicator;
- Throttle: Grip type hand throttle, electrically-controlled;
- Fuel filter: Replaceable paper element;
- Batteries: Two 12V×180Ah capacity batteries, connected in series;
- Fuel tank capacity: 400L.

Electrical Control System

- Self-developed SYIC-II integrated control system is adopted with higher integration, precise operation and reliable quality;
- Control system consists of power system, engine system, main control system, LMI system, auxiliary system and safety monitoring system. CAN BUS is used for data communication between controller, monitor and the engine;
- Monitor: the working parameters and status are shown on the monitor, such as the engine speed, fuel volume, engine oil pressure, servo pressure, wind speed, engine working hours, lifting conditions and boom angle.

Hydraulic System

- Main pumps: three open variable displacement piston pumps are adopted to provide oil supply for main actuators of main machine;
- Gear pump: two types of gear pump for radiator and control circuit;
- Control: main pump adopts electrically-controlled positive flow control; winch motor adopts limitless adjustable piston motor of variable displacement. The operating components are three parallel hydraulic handles, one dual handle for travel and one cross hydraulic handle, to control various actuators proportionally;
- Way of cooling: heat exchanger, plate-fin type core and multi-stage cooling;
- Filter: large flow, high precision filter, with bypass valve and transmitter, which can remind the user to replace the filter element in time;
- Max. pressure of system: 32MPa;
- Main/aux. load hoist and travel system: 32MPa;
- Swing system: 32MPa;
- Control system: 5MPa;
- Hydraulic Tank Capacity:460L.

Main and Aux. Load Hoist Mechanism

- Main and aux. hoist winches are driven separately by motor via gearbox. Operating winch handle can control the winch to rotate to two directions, which are lifting and lowering of hook. Excellent inching function is equipped on the machine;
- Drums with fold-line grooves can ensure the wire rope reeved in order in multilayers;
- Free fall for main/aux. load hoist is offered as optional.

| | | |
|---------------------------------------|--|------------|
| Main Load Hoist Mechanism | Drum diameter | 520mm |
| | 1st layer rope speed | 0~120m/min |
| | Wire rope diameter | 22mm |
| | Wire rope length of main load hoist | 180m |
| | Rated single line pull | 7t |
| Auxiliary Load Hoist Mechanism | Drum diameter | 520mm |
| | 1st layer rope speed | 0~120m/min |
| | Wire rope diameter | 22mm |
| | Wire rope length of auxiliary load hoist | 130m |
| | Rated single line pull | 7t |



Product Specification

Boom Hoist Mechanism

- Boom hoist winches are driven separately by motor via gearbox. Operating winch handle can control the winch to rotate to two directions, which are lifting and lowering of boom;
- Drums with fold-line grooves can ensure the wire rope reeved in order in multilayers.

| | | |
|----------------------|--------------------------------|-----------|
| Boom hoist mechanism | Drum diameter | 290mm |
| | Single rope speed | 0~95m/min |
| | Wire rope diameter | 16mm |
| | Wire rope length of boom hoist | 142m |
| | Rated single line pull | 3.7t |

Swing Mechanism

- Swing brake adopts wet, spring loaded, normally-closed brake, and braking through spring force;
- Swing system has three work modes to accommodate different needs. It is featured in small backlash, steady control, and excellent inching function. It also has free slipping function and swing control on slope to avoid sudden braking;
- Swing drive: internal engaged swing drive with 360° swing range, and the max. swing speed is 3.5r/min. The max. drive pressure can reach 32MPa;
- Swing lock: cylinder lock can ensure the upperworks locked securely on four directions after work or during transport;
- Swing ring: single row ball bearing.

Cab and Control

- Novel operator's cab with fashionable profile and nice interior. There are low and high-beam lights, back-view mirror, heater and A/C, radio and other functions. The layout of seat, handles, control buttons are designed with ergonomic principles to make operation more comfortable;
- Cab layout: Integrated 10.4-inch touch screen, programmable smart switches, vibration handles are offered as optional and man-machine interaction interface are more perfect;
- Armrest box: on the left and right armrest box are control handles, electrical switches, emergent stop and ignition switch. The armrest box can be adjusted along with the seat;
- Seat: multi-way and multi-level floating adjustable seat with unload switch;
- A/C: cool and heat air; optimized air channels and vents;
- Multiple cameras can present on the monitor at the same time to realize real-time monitoring of machine backing, wire rope on each winch, conditions behind the counterweight and surrounding the machine.

Counterweight

- Counterweight tray and blocks are piled up for easier assembly and transport;
- Total rear counterweight: total 16t;
- Rear counterweight: counterweight tray 6.59t x 1, left counterweight block (1) 2.35t x 1, right counterweight block(1) 2.27t x 1, left counterweight block (2) 2.43t x 1, right counterweight block(2) 2.43t x 1.

Upperworks

- High-strength steel weld framework, with no torsion or deformation. The parts are laid out in the way that is easier for maintenance and service.

Product Specification



Lowerworks

- Independent travel driving units are adopted for each side of the crawler, to realize straight walking and turning driven by travel motor through gearbox and drive wheel.

Crawler Extension and Retraction

- The crawlers can extend and retract via cylinders. During Work Mode, the crawlers must be extended, and be retracted during transport with crawlers on.

Crawler Tensioning

- The jack is used to push the guide wheel and insert the shim to adjust crawler tension.

Track Pad

- High-strength alloy cast steel track pad can prolong the service life. They are 762mm wide, and the total amount is 59pcs x 2.

Operating Equipment

- All chords are high-strength steel tubes, and the boom/jib top sheaves are made of high-strength anti-wearing Nylon material protecting wire rope. The hooks are installed with milled welded steel sheave. Pendant cables with quick hitch connector that are easy to assemble are offered as options.

Boom

- Lattice structure. The chord adopts high-strength structural tube and each section is connected through pins;
- Basic boom: 6.5m boom top + 6.5m boom base;
- Boom insert: 3m x 1, 6m x 3, 9m x 2;
- Boom length: 13m~52m.

Fixed Jib

- Lattice structure. The chord adopts high-strength structural tube and each section is connected through pins;
- Basic boom: 3.05m boom top + 3.05m boom base;
- Boom insert: 3.05m x 3;
- Jib length: 6.1m~15.25m;
- Longest boom + jib: 43m boom + 15.25m jib.

Extension Jib

- The extension jib is a welded structure connected to the boom top by pins, used for auxiliary hook;
- Extension jib length: 1.0m.

Hook Block

- 60t hook block, five sheaves;
- 45t hook block, three sheaves;
- 15t hook block, one sheave;
- 9t ball hook.



Safety Device

Assembly Mode/Work Mode Switch

- In Assembly Mode, certain safety devices are disabled to facilitate crane assembly;
- In Work Mode, all safety devices activate to protect the operation.

Emergent Stop

- In emergent situation, this button is pressed down to cut off the power supply of the whole machine and all actions stop.

Load Moment Indicator (LMI)

- It is an independent computerized safety control system. LMI can automatically detect the load weight, work radius and boom angle, and present on the display the rated load, actual load, work radius and boom angle. In normal operation, the LMI can make a judgment and cut off automatically if the crane moves towards dangerous direction. It can also perform as a black box to record the lifting information;
- It is composed of monitor, angle sensor, force sensor and other parts.

Over-hoist Protection of the Main/ Auxiliary Load Hoist

- Over-hoist protection device comprises limit switch and weight on boom top, which prevents the hook lifting up too much. When the hook lifts up to the limit height, the limit switch activates, buzzer on the left control panel sends alarm, failure indicator light starts to flash and the hook hoisting action is cut off automatically.

Over-release Protection Device of the Main/Auxiliary Load Hoist

- It is comprised of activator in the drum and proximity switch to prevent over release of wire rope. When the rope is paid out close to the last three wraps, the proximity switch acts, and the system sends alarm through buzzer and show the alarm on the monitor, automatically cutting off the winch action.

Function Lock

- If the function lock level is not in work position, all the other handles won't work, which prevents any mis-operation caused by accidental collision.

Boom Hoist Drum Lock

- Hydraulically controlled lock is installed for boom hoist drum, which needs to unlock by switch before operation, in order to prevent mis-operation of handles and ensure safety during non-work time.

Swing Lock

- Swing Lock can lock the machine.

Boom Limit Device

- When the boom elevation angle reaches the upper limit, the buzzer sounds and boom action is cut off. This protection is two-stage control ensured by both LMI system and travel switch.

Back-stop Device

- Its major components are nesting tubes and spring, in order to buffer the boom backlash and prevent further tipping back.

Boom Angle Indicator

- Pendulum angle indicator is fixed on the side of boom base close to the cab, so as to provide convenience to the operator.

Hook Latch

- The lifting hook is installed with a baffle plate to prevent wire rope from falling off.

Safety Device



Tri-color Load Indicator

- The load indication light has three colors, green, yellow and red, and the real time load status is presented on the display. When the actual load is smaller than 90% of rated load, the green light is on; when the actual load is larger than 90% and smaller than 100%, the yellow light is on, the alarm light flashes and sends out intermittent sirens; when the actual load reaches 100% of rated load, the red light is on, the alarm light flashes and sends out continuous sirens. At this moment, the system will automatically cut off the crane's dangerous operation.

Alarm Light

- When the machine is powered on, the alarm light will work when time comes, so as to warn people around.

Swing Indicator Light

- The swing indicator light flashes during traveling or swing.

Illuminating Light

- The machine is equipped with short-beam light in front of machine, front angle adjustable far-beam light, lamps in operator's cab, lighting devices for night operation, so as to increase the visibility during work.

Rearview Mirror

- It is installed on the left of the operator's cab and at the front handrail of the sheet metal for monitoring the rear part of the machine.

Pharos

- Pharos is mounted on the top of boom/jib to indicate the height.

Anemometer

- It is mounted on the top of boom/jib, and displayed on the monitor in the cab.

Electronic Level Gauge

- It displays the tipping angle of crane on the monitor in real time and sends out alarm to the operator automatically when the angle is out of limit.

Seat Interlock

- If the operator leaves the seat, all control handles will be locked immediately to prevent any mis-operation due to accidental collision.

Engine Power Limit Load Adjustment and Stalling Protection

- The controller monitors the engine power to prevent engine getting stuck and stalling.

Engine Status Monitoring

- The engine status will be presented, such as engine coolant temperature, fuel volume, total work hours, engine oil pressure, engine speed, battery charging and voltage.

Monitoring System

- Remote Monitoring system is a standardized offering to provide functions like GPS locating, GPRS data transfer, machine status inquiry and statistics, operating data monitoring and analysis, remote diagnosis of failures.

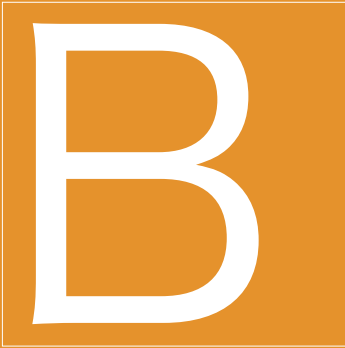

SCE600A
SANY CRAWLER CRANE
60 TONS LIFTING CAPACITY

QUALITY CHANGES THE WORLD

Technical Parameters

- Page 10 Major Performance & Specifications
- Page 11 Outline Dimension
- Page 12 Transport Dimension
- Page 16 Transport Plan

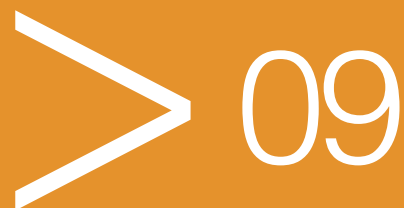

Major Performance & Specifications

| Major Performance & Specifications of SCE600A | | | |
|---|---|----------|-----------------|
| Performance Indicators | | Unit | Parameter |
| Boom Configuration | Max. rated lifting capacity | t | 60 |
| | Largest lifting moment | t·m | 222 |
| | Boom length | m | 13~52 |
| Fixed Jib | Max. rated lifting capacity | t | 7 |
| | Jib length | m | 6.1~15.25 |
| | Longest boom + jib | m | 43+15.25 |
| Speed | Rope speed of main/aux. winch (1st layer) | m/min | 120 |
| | Rope speed of boom hoist winch | m/min | 95 |
| | Swing speed | rpm | 0~3.5 |
| | Travel speed | km/h | 0~2.0 |
| Wire rope | Main load hoist wire rope: diameter × length | φ mm × m | 22×180 |
| | Aux. load hoist wire rope: diameter × length | φ mm × m | 22×130 |
| | Rated single line pull of main/aux. hoist wire rope | t | 7 |
| Engine | Model/Displacement | \L | B6.7/6.7 |
| | Rated power/revolution speed | kW/ rpm | 145/2000 |
| Transport Parameters | Weight of machine with basic boom | t | 50 |
| | Rear counterweight | t | 16 |
| | Transport weight of basic machine (with crawlers and boom base) | t | 32.3 |
| | Machine transport dimension (with crawlers and boom base) L×W×H | mm | 12200×3000×3200 |
| Other specifications | Average ground pressure (basic boom) | MPa | 0.065 |
| | Gradeability | % | 40 |

Unit: mm

Outline Dimension

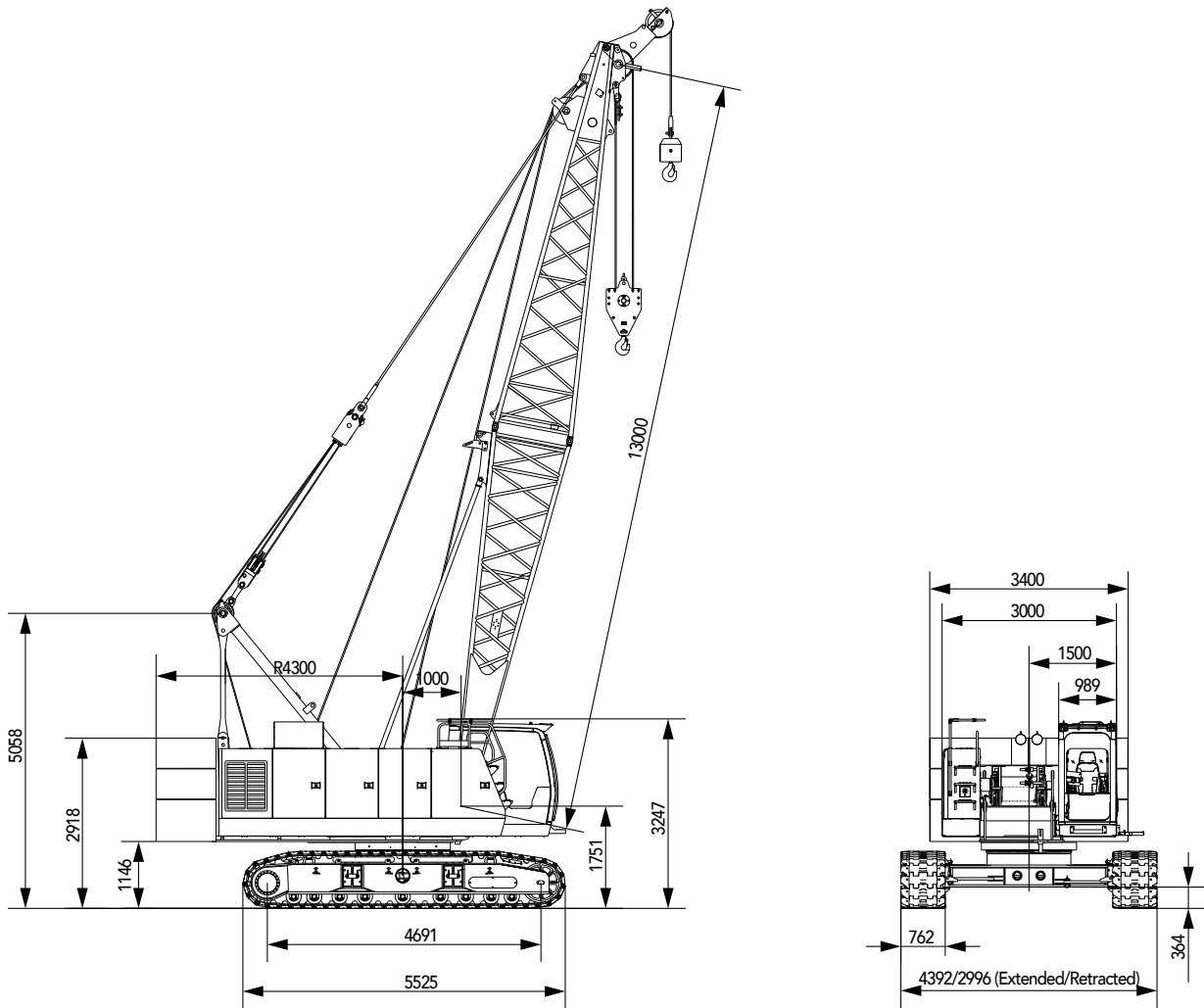

Transport Dimension

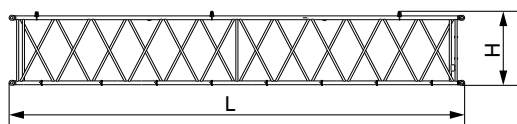
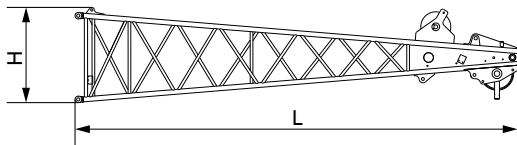
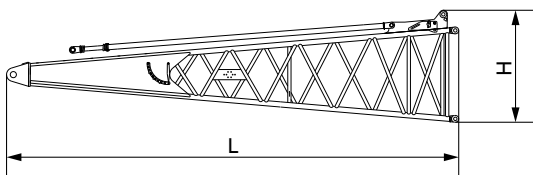
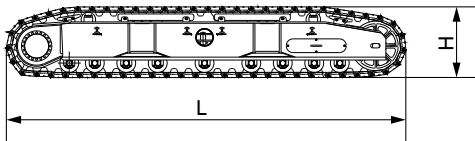
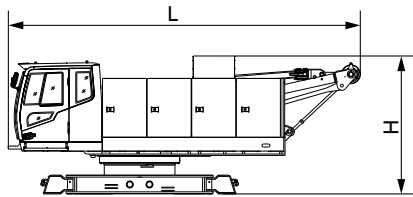
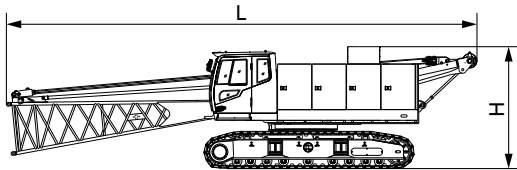

Basic Machine 1 (with boom base and crawler frames)

×1

| | |
|-----------|-------|
| Length(L) | 12.2m |
| Width(W) | 3.0m |
| Height(H) | 3.2m |
| Weight | 32.3t |

Basic Machine 4

×1

| | |
|------------|-------|
| Length (L) | 7.2m |
| Width (W) | 3.00m |
| Height (H) | 2.8m |
| Weight | 18.8t |

Crawler frame

×2

| | |
|------------|-------|
| Length (L) | 5.5m |
| Width (W) | 0.9m |
| Height (H) | 0.98m |
| Weight | 6.1t |

Boom base

×1

| | |
|-----------|-------|
| Length(L) | 6.65m |
| Width(W) | 1.39m |
| Height(H) | 1.65m |
| Weight | 1.35t |

Boom top

×1

| | |
|-----------|-------|
| Length(L) | 6.88m |
| Width(W) | 1.39m |
| Height(H) | 1.48m |
| Weight | 0.9t |

9m boom insert

×2

| | |
|-----------|-------|
| Length(L) | 9.1m |
| Width(W) | 1.39m |
| Height(H) | 1.48m |
| Weight | 0.85t |

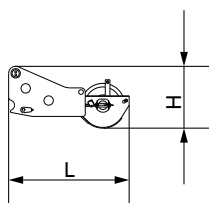
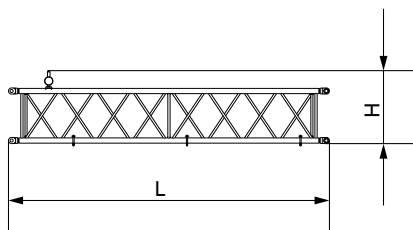
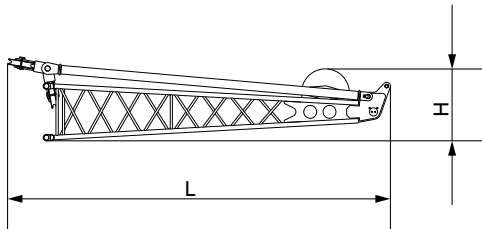
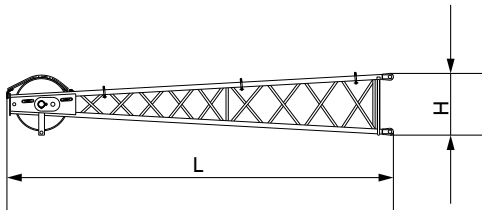
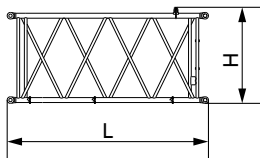
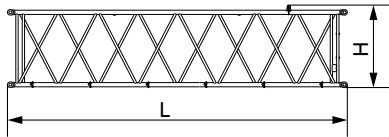
Transport Dimension

| 6m boom insert | ×3 |
|----------------|-------|
| Length(L) | 6.1m |
| Width(W) | 1.39m |
| Height(H) | 1.48m |
| Weight | 0.55t |

| 3m boom insert | ×1 |
|----------------|-------|
| Length (L) | 3.1 m |
| Width (W) | 1.39m |
| Height (H) | 1.48m |
| Weight | 0.33t |

| Fixed jib top | ×1 |
|---------------|-------|
| Length (L) | 3.38m |
| Width (W) | 0.7m |
| Height (H) | 0.55m |
| Weight | 0.15t |

| Fixed jib base and strut | ×1 |
|--------------------------|-------|
| Length(L) | 3.57m |
| Width(W) | 0.61m |
| Height(H) | 0.78m |
| Weight | 0.25t |

| 3.05m fixed jib | ×3 |
|-----------------|-------|
| Length(L) | 3.11m |
| Width(W) | 0.62m |
| Height(H) | 0.7m |
| Weight | 0.1t |

| Boom extension jib | ×1 |
|--------------------|-------|
| Length(L) | 1.35m |
| Width(W) | 0.7m |
| Height(H) | 0.66m |
| Weight | 0.18t |

Transport Dimension

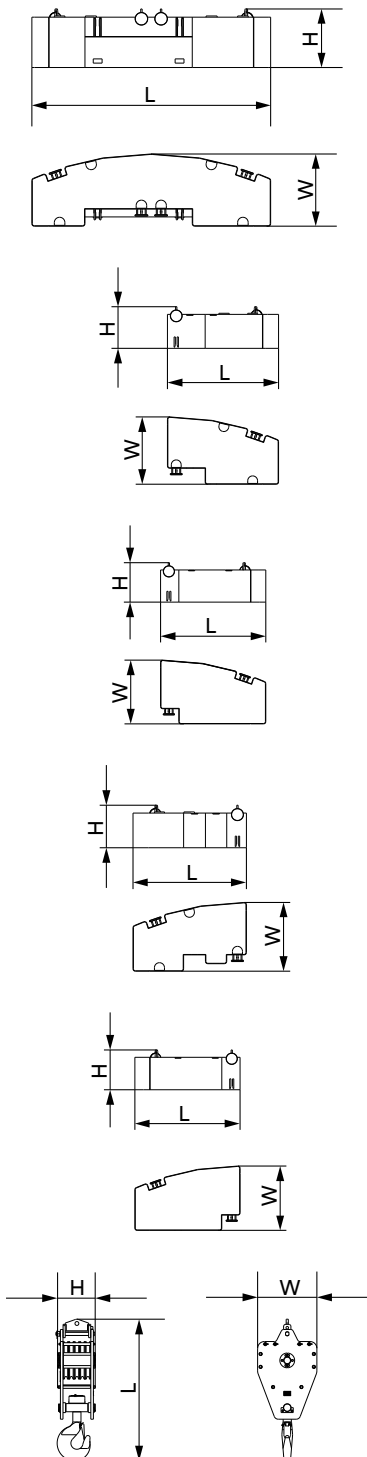

Counterweight tray ×1

| | |
|-----------|-------|
| Length(L) | 3.4m |
| Width(W) | 1.03m |
| Height(H) | 0.84m |
| Weight | 6.59t |

Left counterweight block 1 ×1

| | |
|------------|-------|
| Length (L) | 1.69m |
| Width (W) | 1.03m |
| Height (H) | 0.64m |
| Weight | 2.35t |

Left counterweight block 2 ×1

| | |
|------------|-------|
| Length (L) | 1.69m |
| Width (W) | 1.03m |
| Height (H) | 0.64m |
| Weight | 2.43t |

Right counterweight block 1 ×1

| | |
|-----------|-------|
| Length(L) | 1.69m |
| Width(W) | 1.03m |
| Height(H) | 0.64m |
| Weight | 2.27t |

Right counterweight block 2 ×1

| | |
|-----------|-------|
| Length(L) | 1.69m |
| Width(W) | 1.03m |
| Height(H) | 0.64m |
| Weight | 2.43t |

60T hook ×1

| | |
|-----------|-------|
| Length(L) | 1.65m |
| Width(W) | 0.69m |
| Height(H) | 0.39m |
| Weight | 0.65t |

Transport Dimension

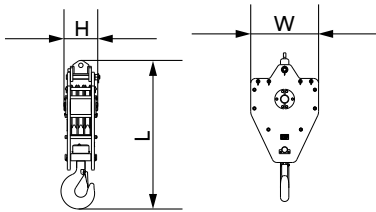

45T hook ×1

| | |
|-----------|-------|
| Length(L) | 1.52m |
| Width(W) | 0.69m |
| Height(H) | 0.37m |
| Weight | 0.48t |

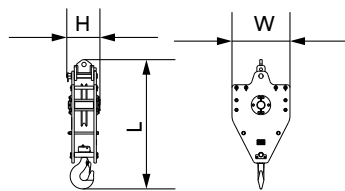

15T hook ×1

| | |
|------------|-------|
| Length (L) | 1.34m |
| Width (W) | 0.6m |
| Height (H) | 0.34m |
| Weight | 0.28t |

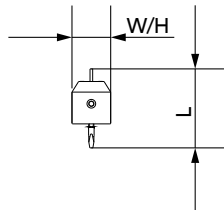

9T ball hook ×1

| | |
|------------|--------|
| Length (L) | 0.75m |
| Width (W) | 0.37m |
| Height (H) | 0.37m |
| Weight | 0.255t |

Note:

- 1.The transport dimensions of each part in the table are schematic, not proportional to the real parts. The dimensions are designed value without package considered.
- 2.The Weight is designed value that the actual manufactured part may deviate a little

Transport Plan

Transport with crawler frames

Trailer 1

| | |
|---------|-----------------|
| Part(s) | ▪ Basic Machine |
| Weight | ▪ 32.3t |

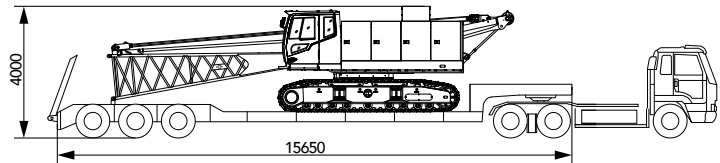

Trailer 2

| | |
|---------|--|
| Part(s) | <ul style="list-style-type: none"> ▪ 9m boom × 2 ▪ 6m boom × 3 ▪ 3m boom × 1 ▪ Boom top × 1 ▪ Boom extension jib × 1 ▪ 3.05m fixed jib × 3 ▪ Fixed jib base and strut × 1 ▪ Fixed jib top × 1 ▪ Counterweight tray × 1 ▪ Left counterweight block 1 × 1 ▪ Right counterweight block 1 × 1 ▪ Left counterweight block 2 × 1 ▪ Right counterweight block 2 × 1 ▪ 60t hook × 1 ▪ 45t hook × 1 ▪ 15t hook × 1 ▪ 9t hook × 1 |
| Weight | ▪ 23.2t |

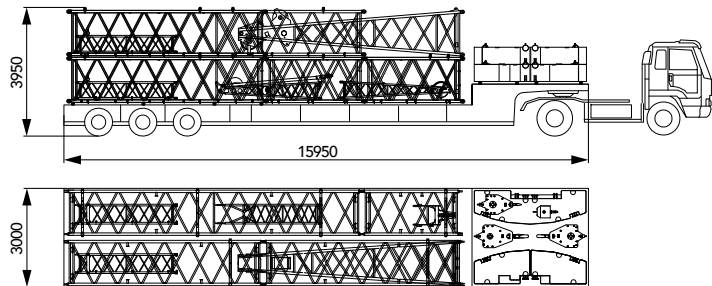



SCE600A
SANY CRAWLER CRANE
60 TONS LIFTING CAPACITY

QUALITY CHANGES THE WORLD

Boom Combination

- Page 19 H Configuration
- Page 22 FJ Configuration

> 17

Boom Combination

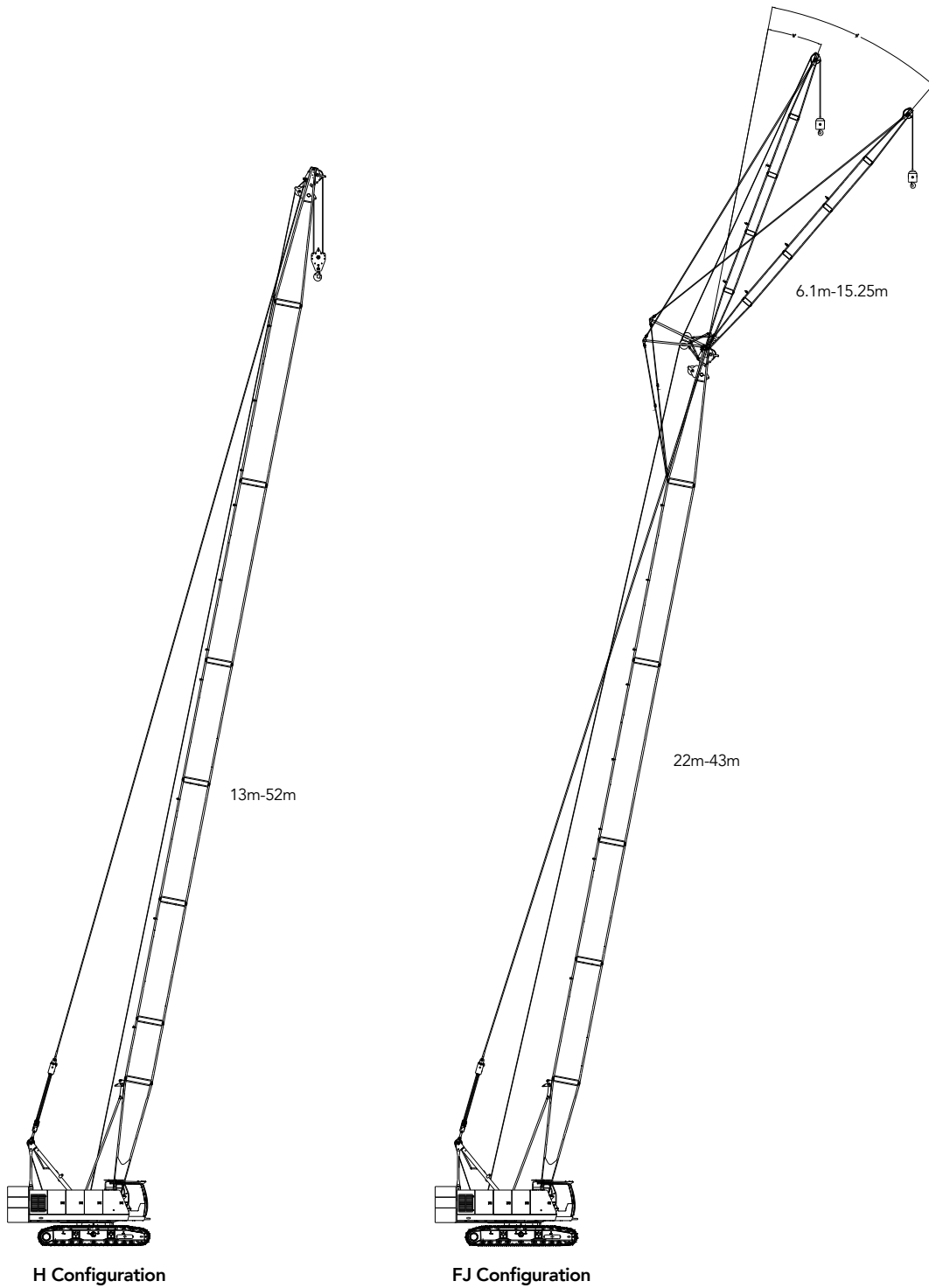

H Configuration

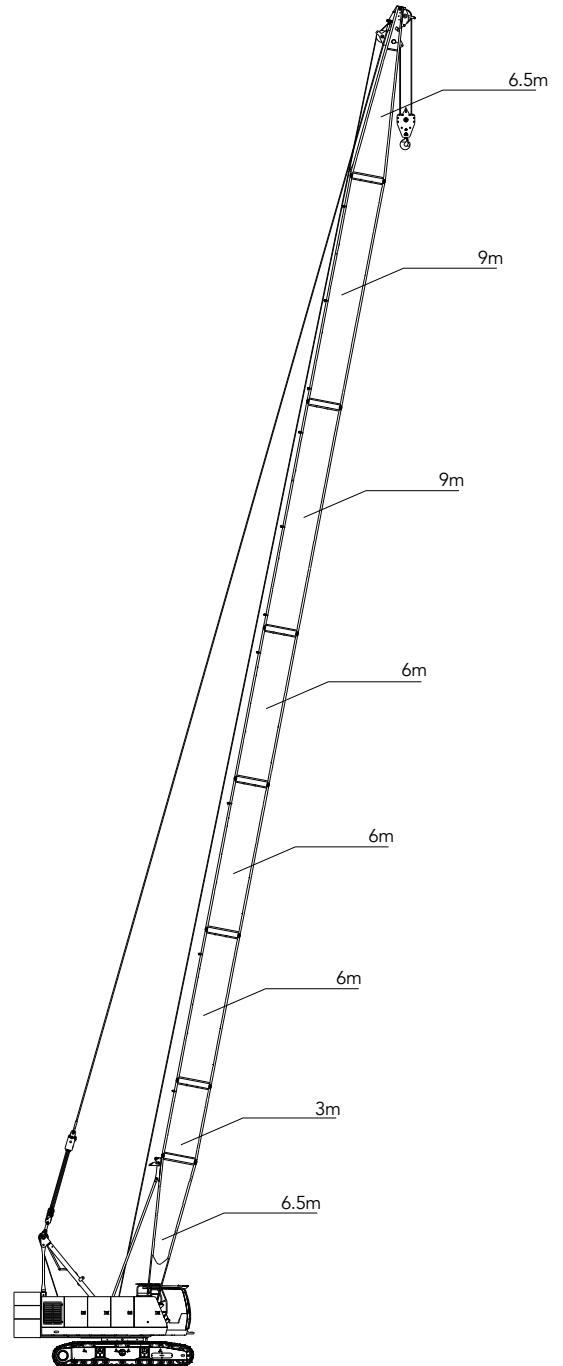
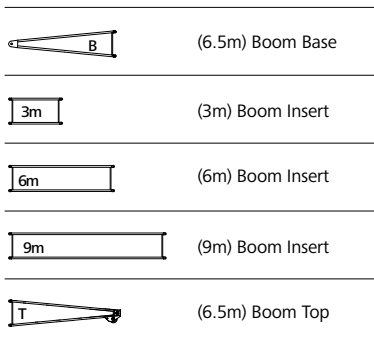
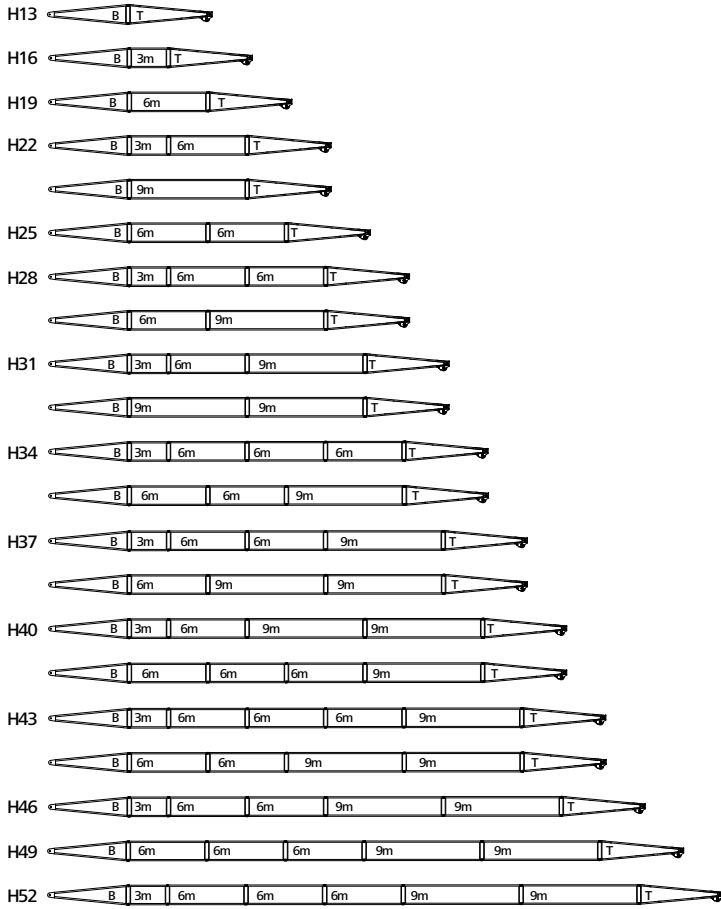

Working Radius in H Configuration

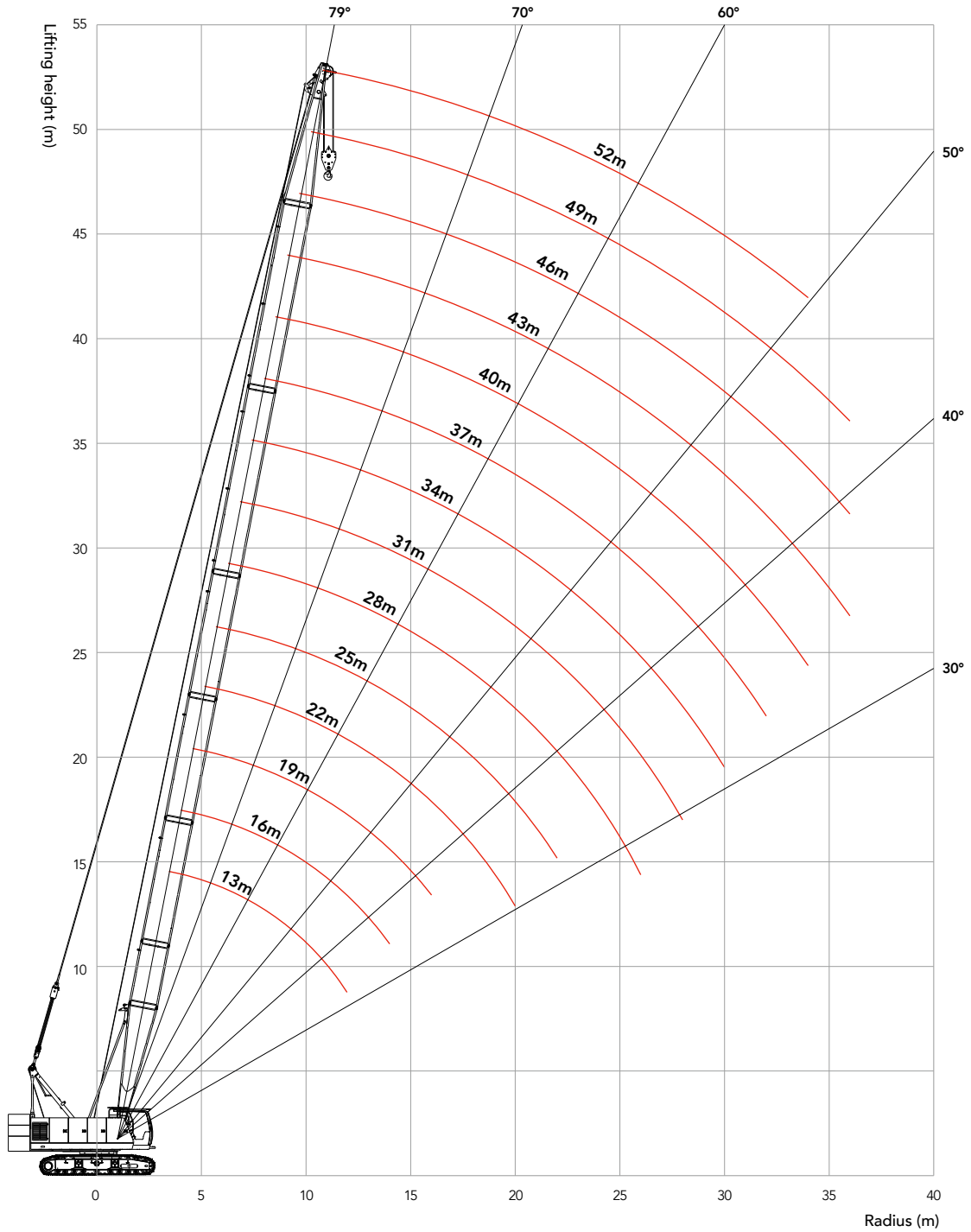

Unit: t

Load Chart of H Configuration

| SCE600A Crawler Crane –H Configuration | | | | | | | | | | | | | | | |
|--|------------------------|------|------|------|------|------|------|------|------|------|------|------|------|-----|-------------|
| R/BL (m) | Rear counterweight 16t | | | | | | | | | | | | | | R/BL (m) |
| | 13 | 16 | 19 | 22 | 25 | 28 | 31 | 34 | 37 | 40 | 43 | 46 | 49 | 52 | |
| 3.7 | 60 | | | | | | | | | | | | | | 3.7 |
| 4 | 50.2 | 48.2 | | | | | | | | | | | | | 4 |
| 4.5 | 42.5 | 41.8 | 40.2 | | | | | | | | | | | | 4.5 |
| 5 | 37.5 | 36 | 35 | 33.2 | | | | | | | | | | | 5 |
| 5.5 | 32.5 | 31.9 | 31 | 30.2 | 28.2 | | | | | | | | | | 5.5 |
| 6 | 28.5 | 28.3 | 27.5 | 27.2 | 26.2 | 25.2 | | | | | | | | | 6 |
| 7 | 22.9 | 22.7 | 22.5 | 22.2 | 21.7 | 21.2 | 20.5 | | | | | | | | 7 |
| 8 | 19.2 | 19 | 18.7 | 18.5 | 18.5 | 18 | 17.5 | 17.1 | 16.7 | | | | | | 8 |
| 9 | 16.1 | 15.7 | 15.7 | 15.6 | 15.5 | 15.4 | 14.8 | 14.2 | 14 | 13.2 | 12.8 | | | | 9 |
| 10 | 14.2 | 14 | 13.9 | 13.9 | 13.7 | 13.7 | 13.5 | 13.2 | 12.8 | 12.5 | 12.1 | 11.7 | 11.3 | | 10 |
| 12 | 11.3 | 11.2 | 11.1 | 11 | 10.9 | 10.8 | 10.8 | 10.5 | 10.3 | 10 | 9.6 | 9.3 | 9.2 | 9.2 | 12 |
| 14 | | 9.3 | 9.2 | 9.1 | 9 | 8.8 | 8.8 | 8.6 | 8.5 | 8.2 | 8 | 7.7 | 7.4 | 7.4 | 14 |
| 16 | | | 7.8 | 7.7 | 7.6 | 7.5 | 7.4 | 7.2 | 7.1 | 6.9 | 6.9 | 6.6 | 6.4 | 6.2 | 16 |
| 18 | | | | 6.6 | 6.5 | 6.5 | 6.4 | 6.2 | 6.1 | 5.9 | 5.8 | 5.5 | 5.3 | 5.1 | 18 |
| 20 | | | | 5.6 | 5.6 | 5.5 | 5.5 | 5.3 | 5.2 | 4.9 | 4.9 | 4.7 | 4.4 | 4.3 | 20 |
| 22 | | | | | 4.8 | 4.8 | 4.6 | 4.5 | 4.3 | 4.2 | 4.1 | 3.9 | 3.7 | 3.6 | 22 |
| 24 | | | | | | 4.2 | 4 | 3.9 | 3.7 | 3.6 | 3.5 | 3.3 | 3.2 | 3 | 24 |
| 26 | | | | | | 3.6 | 3.6 | 3.4 | 3.3 | 3.2 | 3 | 2.9 | 2.7 | 2.5 | 26 |
| 28 | | | | | | | 3 | 3 | 2.9 | 2.7 | 2.5 | 2.4 | 2.3 | 2.1 | 28 |
| 30 | | | | | | | | 2.6 | 2.5 | 2.3 | 2.1 | 2 | 1.9 | 1.7 | 30 |
| 32 | | | | | | | | | 2.1 | 2 | 1.8 | 1.7 | 1.6 | 1.4 | 32 |
| 34 | | | | | | | | | | 1.7 | 1.5 | 1.4 | 1.3 | 1.2 | 34 |
| 36 | | | | | | | | | | | 1.1 | 1 | 0.9 | | 36 |

Notes: Rated capacity of crawler crane

- ① The rated capacity in the load charts is calculated when the crane is parking on firm and level ground, lifting the load slowly and steadily.
- ② The shaded values are determined by strength.
- ③ The rated capacity values in the load charts are only valid when wind speed is lower than 9.8m/s.
- ④ The rated capacity in the load charts includes the weight of hook, wire rope and other riggings; therefore, the actual rated capacity shall deduct the weight of these components.
- ⑤ The crawlers must be extended during lifting.
- ⑥ The values in the load charts are valid for 360° swing.

FJ Configuration

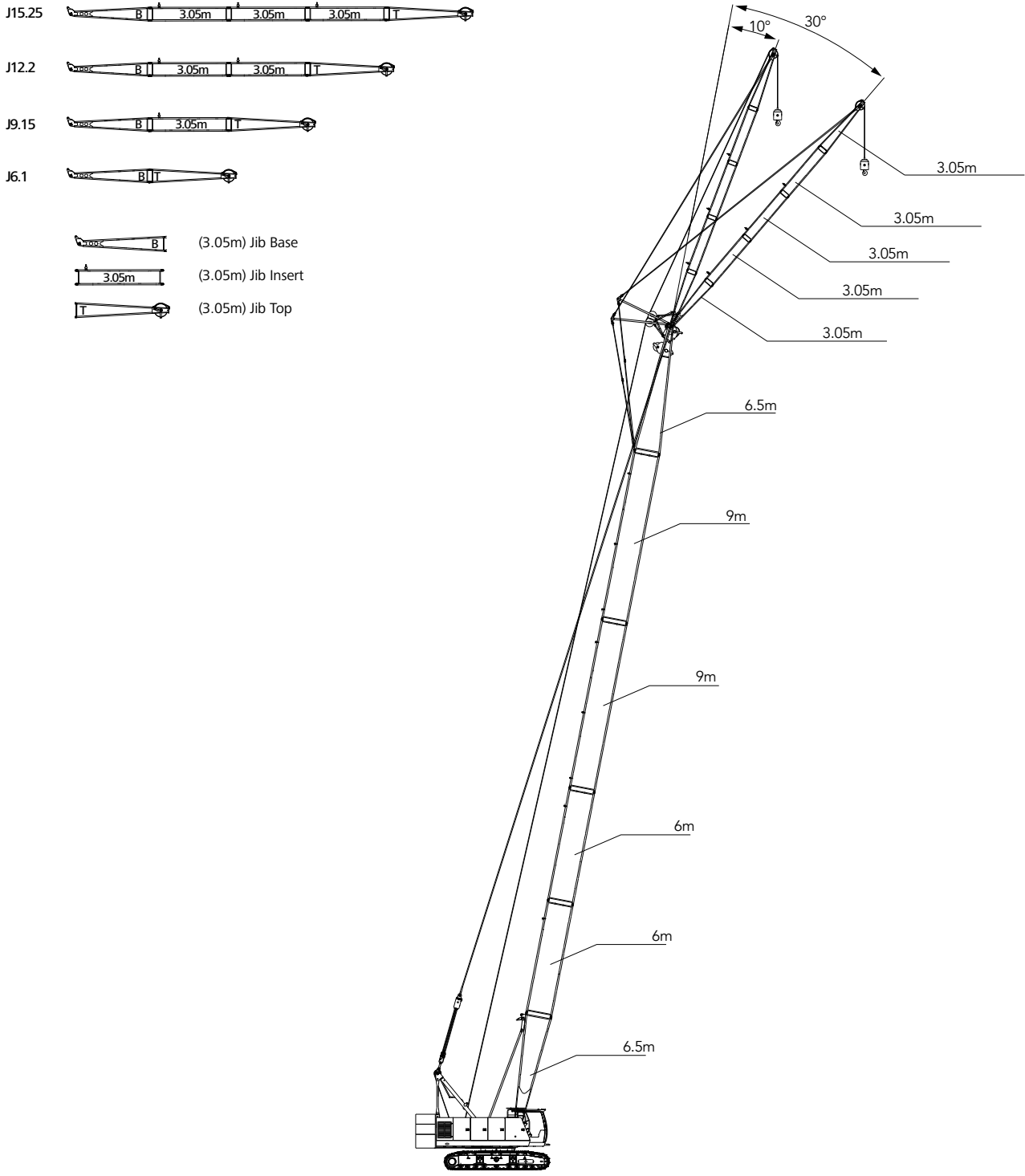

Longest boom + jib: 43m+15.25m

Working Radius in FJ Configuration

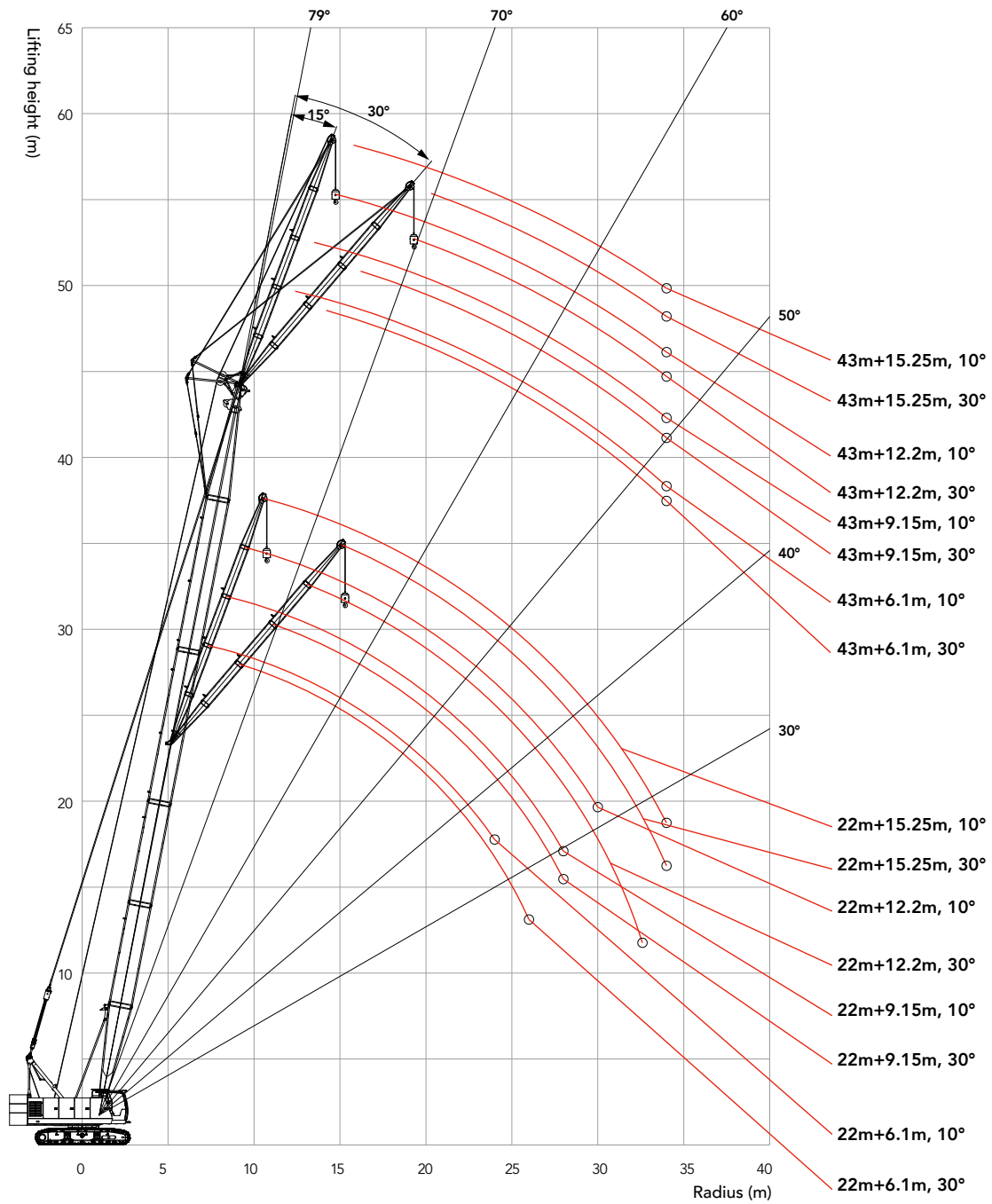

Load Chart of FJ Configuration

| SCE600A Crawler Crane – FJ Load Chart 1/8 | | | | | | | | | | |
|---|--|----------|------------|-----------------------|------|------------------------|-------------|-------------|------|------------------|
| | | Boom 22m | | Fixed jib 6.1m-15.25m | | Rear counterweight 16t | | | | |
| Jib Length (m) | | 6.1 | | 9.15 | | 12.2 | | 15.25 | | Jib Length (m) |
| Jib angle | | 10° | 30° | 10° | 30° | 10° | 30° | 10° | 30° | Jib angle |
| R(m) | | | | | | | | | | R(m) |
| 8 | | 7.00 | 9.8m × 6.5 | 9.2m × 7 | | | | | | 8 |
| 10 | | 7.00 | 6.30 | 7.00 | | 10.3m × 4.5 | | 11.4m × 4.5 | | 10 |
| 12 | | 7.00 | 6.00 | 7.00 | 4.80 | 4.50 | | 4.40 | | 12 |
| 14 | | 7.00 | 5.50 | 7.00 | 4.65 | 4.50 | 4.00 | 4.40 | | 14 |
| 16 | | 7.00 | 5.00 | 6.50 | 4.45 | 4.50 | 3.50 | 4.00 | 3.50 | 16 |
| 18 | | 6.00 | 5.00 | 5.80 | 4.25 | 4.15 | 3.50 | 4.00 | 3.25 | 18 |
| 20 | | 4.90 | 5.00 | 5.00 | 4.05 | 3.95 | 3.50 | 3.85 | 3.05 | 20 |
| 22 | | 4.30 | 4.35 | 4.35 | 3.85 | 3.85 | 3.50 | 3.60 | 2.90 | 22 |
| 24 | | 3.90 | 4.00 | 4.00 | 3.50 | 3.65 | 3.25 | 3.35 | 2.85 | 24 |
| 26 | | | 3.85 | 3.85 | 3.45 | 3.55 | 3.20 | 3.25 | 2.75 | 26 |
| 28 | | | | 3.05 | 3.05 | 3.05 | 3.05 | 3.05 | 2.70 | 28 |
| 30 | | | | | | 2.75 | 2.75 | 2.75 | 2.65 | 30 |
| 32 | | | | | | | 2.50 | 2.50 | 2.20 | 32 |
| 34 | | | | | | | 32.6m × 2.5 | 2.30 | 2.15 | 34 |
| Counterweight(t) | | 16 | 16 | 16 | 16 | 16 | 16 | 16 | 16 | Counterweight(t) |

Note: The shaded area is determined by the boom strength.

Unit: t

Load Chart of FJ Configuration

| SCE600A Crawler Crane – FJ Load Chart 2/8 | | | | | | | | | | |
|---|-----------|-----------|------|-----------------------|------|------------------------|-------------|-------------|-----|----------------|
| | | Boom 25m | | Fixed jib 6.1m-15.25m | | Rear counterweight 16t | | | | |
| Jib Length (m) | Jib angle | 6.10 | | 9.15 | | 12.20 | | 15.25 | | Jib Length (m) |
| R(m) | | 10° | 30° | 10° | 30° | 10° | 30° | 10° | 30° | R(m) |
| 8 | 8.6m × 7 | | | | | | | | | 8 |
| 10 | 7.00 | 10.4m × 6 | 7.00 | | | 10.9m × 4.5 | | | | 10 |
| 12 | 7.00 | 6.00 | 7.00 | 12.5m × 4.8 | 4.50 | | 12.1m × 4.5 | | | 12 |
| 14 | 7.00 | 5.50 | 7.00 | 4.65 | 4.50 | 14.5m × 4.0 | 4.40 | | | 14 |
| 16 | 7.00 | 5.50 | 6.50 | 4.45 | 4.35 | 3.50 | 4.25 | 16.6m × 3.5 | | 16 |
| 18 | 6.00 | 5.00 | 5.50 | 4.25 | 4.15 | 3.50 | 4.00 | 3.25 | | 18 |
| 20 | 4.90 | 5.00 | 5.00 | 4.05 | 3.95 | 3.50 | 3.85 | 3.05 | | 20 |
| 22 | 4.30 | 4.35 | 4.35 | 3.85 | 3.85 | 3.50 | 3.60 | 2.90 | | 22 |
| 24 | 3.90 | 4.00 | 4.00 | 3.50 | 3.65 | 3.25 | 3.35 | 2.85 | | 24 |
| 26 | 3.80 | 3.85 | 3.85 | 3.45 | 3.55 | 3.20 | 3.25 | 2.75 | | 26 |
| 28 | 3.00 | 3.05 | 3.05 | 3.05 | 3.05 | 3.05 | 3.05 | 2.70 | | 28 |
| 30 | | | 2.65 | 2.75 | 2.75 | 2.75 | 2.75 | 2.65 | | 30 |
| 32 | | | | 2.40 | 2.40 | 2.40 | 2.40 | 2.20 | | 32 |
| 34 | | | | | | 2.25 | 2.20 | 2.15 | | 34 |

Note: The shaded area is determined by the boom strength.

Load Chart of FJ Configuration

| SCE600A Crawler Crane – FJ Load Chart 3/8 | | | | | | | | | | |
|---|-----------|-------------|-----------|-----------------------|-------------|------------------------|-------------|-------------|-------------|------------------------|
| Jib Length (m) R(m) | Jib angle | Boom 28m | | Fixed jib 6.1m-15.25m | | Rear counterweight 16t | | 15.25 | | Jib Length (m) R(m) |
| | | 6.1 | 9.15 | 9.15 | 12.2 | 12.2 | 15.25 | 15.25 | | |
| | | 10° | 30° | 10° | 30° | 10° | 30° | 10° | 30° | |
| 8 | | 9.3m × 7 | | | | | | | | 8 |
| 10 | | 7.00 | 11.1m × 6 | 10.4m × 7 | | 11.6m × 4.5 | | | | 10 |
| 12 | | 7.00 | 6.00 | 7.00 | 13.1m × 5.0 | 4.50 | | 12.7m × 4.0 | | 12 |
| 14 | | 7.00 | 5.50 | 7.00 | 4.80 | 4.50 | 15.1m × 3.8 | 3.50 | | 14 |
| 16 | | 7.00 | 5.50 | 6.50 | 4.55 | 4.30 | 3.80 | 3.50 | 17.2m × 3.2 | 16 |
| 18 | | 6.00 | 5.00 | 5.50 | 4.05 | 4.05 | 3.70 | 3.50 | 3.20 | 18 |
| 20 | | 5.00 | 5.00 | 5.00 | 3.85 | 3.95 | 3.55 | 3.45 | 3.05 | 20 |
| 22 | | 4.50 | 4.50 | 4.50 | 3.70 | 3.85 | 3.45 | 3.25 | 2.95 | 22 |
| 24 | | 4.00 | 4.00 | 4.00 | 3.50 | 3.65 | 3.25 | 3.35 | 2.85 | 24 |
| 26 | | 3.80 | 3.85 | 3.85 | 3.45 | 3.55 | 3.20 | 3.25 | 2.75 | 26 |
| 28 | | 3.00 | 3.05 | 3.05 | 3.05 | 3.05 | 3.05 | 3.05 | 2.70 | 28 |
| 30 | | 2.60 | 2.65 | 2.65 | 2.75 | 2.75 | 2.75 | 2.75 | 2.65 | 30 |
| 32 | | 31.3m × 2.3 | | 2.30 | 2.30 | 2.35 | 2.40 | 2.35 | 2.20 | 32 |
| 34 | | | | 2.05 | 2.10 | 2.10 | 2.15 | 2.10 | 2.15 | 34 |

Note: The shaded area is determined by the boom strength.

Unit: t

Load Chart of FJ Configuration

| SCE600A Crawler Crane – FJ Load Chart 4/8 | | | | | | | | | | |
|---|-----------|----------|-----------|-----------------------|------|------------------------|------|-------------|------|----------------|
| | | Boom 31m | | Fixed jib 6.1m-15.25m | | Rear counterweight 16t | | | | |
| Jib Length (m) | Jib angle | 6.10 | | 9.15 | | 12.20 | | 15.25 | | Jib Length (m) |
| R(m) | | 10° | 30° | 10° | 30° | 10° | 30° | 10° | 30° | R(m) |
| 10 | | 7.00 | 11.7m × 6 | 11.0m × 7 | | | | | | 10 |
| 12 | | 7.00 | 6.00 | 7.00 | | 12.2m × 4.5 | | 13.3m × 4.0 | | 12 |
| 14 | | 7.00 | 5.50 | 7.00 | 4.75 | 4.50 | | 4.00 | | 14 |
| 16 | | 7.00 | 5.50 | 6.50 | 4.50 | 4.50 | 4.00 | 4.00 | | 16 |
| 18 | | 6.00 | 5.50 | 5.50 | 4.35 | 4.35 | 3.85 | 4.00 | 3.20 | 18 |
| 20 | | 4.80 | 4.85 | 4.85 | 4.25 | 4.15 | 3.70 | 3.85 | 3.15 | 20 |
| 22 | | 4.40 | 4.45 | 4.45 | 4.05 | 3.95 | 3.50 | 3.65 | 3.00 | 22 |
| 24 | | 4.00 | 4.05 | 4.05 | 3.85 | 3.80 | 3.35 | 3.45 | 2.85 | 24 |
| 26 | | 3.80 | 3.85 | 3.85 | 3.45 | 3.55 | 3.20 | 3.25 | 2.75 | 26 |
| 28 | | 3.00 | 3.05 | 3.05 | 3.05 | 3.05 | 3.05 | 3.05 | 2.70 | 28 |
| 30 | | 2.60 | 2.65 | 2.65 | 2.75 | 2.75 | 2.75 | 2.75 | 2.65 | 30 |
| 32 | | 2.20 | 2.25 | 2.25 | 2.25 | 2.35 | 2.35 | 2.30 | 2.30 | 32 |
| 34 | | | 1.95 | 1.95 | 2.00 | 2.00 | 2.10 | 2.05 | 2.15 | 34 |

Note: The shaded area is determined by the boom strength.

Load Chart of FJ Configuration

| SCE600A Crawler Crane – FJ Load Chart 5/8 | | | | | | | | | | | |
|---|------|-----------|-----------|-----------|-------------|-----------------------|--------------|------------------------|-------------|----------------|--|
| | | Boom 34m | | | | Fixed jib 6.1m-15.25m | | Rear counterweight 16t | | | |
| Jib Length (m) | | 6.1 | | 9.15 | | 12.2 | | 15.25 | | Jib Length (m) | |
| Jib angle | | 10° | 30° | 10° | 30° | 10° | 30° | 10° | 30° | Jib angle | |
| R(m) | | | | | | | | | | R(m) | |
| 10 | | 10.5m × 7 | | 11.7m × 7 | | | | | | 10 | |
| 12 | 7.00 | | 12.3m × 6 | 7.00 | | 12.8m × 4.5 | | 13.9m × 3.5 | | 12 | |
| 14 | 7.00 | | 6.00 | 7.00 | 14.4m × 4.8 | 4.50 | | 3.50 | | 14 | |
| 16 | 7.00 | | 5.50 | 6.50 | 4.75 | 4.50 | 16.4m × 3.85 | 3.50 | | 16 | |
| 18 | 5.50 | | 5.50 | 5.50 | 4.65 | 4.35 | 3.75 | 3.50 | 18.4m × 3.2 | 18 | |
| 20 | 4.80 | | 4.85 | 4.85 | 4.45 | 4.15 | 3.55 | 3.50 | 3.15 | 20 | |
| 22 | 4.30 | | 4.35 | 4.35 | 4.20 | 3.95 | 3.45 | 3.35 | 3.05 | 22 | |
| 24 | 3.80 | | 3.85 | 3.85 | 3.90 | 3.75 | 3.35 | 3.30 | 2.95 | 24 | |
| 26 | 3.40 | | 3.45 | 3.45 | 3.45 | 3.45 | 3.15 | 3.20 | 2.85 | 26 | |
| 28 | 3.00 | | 3.05 | 3.05 | 3.05 | 3.05 | 3.05 | 3.05 | 2.80 | 28 | |
| 30 | 2.60 | | 2.65 | 2.65 | 2.75 | 2.75 | 2.75 | 2.75 | 2.65 | 30 | |
| 32 | 2.20 | | 2.25 | 2.25 | 2.25 | 2.35 | 2.35 | 2.30 | 2.35 | 32 | |
| 34 | 1.80 | | 1.85 | 1.85 | 1.95 | 1.90 | 2.00 | 1.95 | 2.05 | 34 | |

Note: The shaded area is determined by the boom strength.

Unit: t

Load Chart of FJ Configuration

| SCE600A Crawler Crane – FJ Load Chart 6/8 | | | | | | | | | | |
|---|-----------|-----------|-----------|-----------------------|-------------|------------------------|-------------|-------------|-------------|----------------|
| | | Boom 37m | | Fixed jib 6.1m-15.25m | | Rear counterweight 16t | | | | |
| Jib Length (m) | Jib angle | 6.10 | | 9.15 | | 12.20 | | 15.25 | | Jib Length (m) |
| R(m) | | 10° | 30° | 10° | 30° | 10° | 30° | 10° | 30° | R(m) |
| 10 | | 11.1m × 7 | | | | | | | | 10 |
| 12 | | 7.00 | 12.9m × 6 | 12.3m × 7 | | 13.4m × 4.5 | | | | 12 |
| 14 | | 7.00 | 6.00 | 7.00 | 15.0m × 4.8 | 4.50 | | 14.6m × 4.0 | | 14 |
| 16 | | 6.50 | 5.50 | 6.50 | 4.80 | 4.50 | 17.0m × 3.8 | 4.00 | | 16 |
| 18 | | 5.50 | 5.50 | 5.50 | 4.60 | 4.50 | 3.75 | 3.80 | 19.1m × 3.2 | 18 |
| 20 | | 4.60 | 4.65 | 4.65 | 4.45 | 4.20 | 3.65 | 3.60 | 3.15 | 20 |
| 22 | | 4.10 | 4.15 | 4.15 | 4.25 | 4.05 | 3.45 | 3.50 | 3.05 | 22 |
| 24 | | 3.60 | 3.65 | 3.65 | 3.75 | 3.75 | 3.35 | 3.35 | 2.95 | 24 |
| 26 | | 3.20 | 3.25 | 3.25 | 3.35 | 3.35 | 3.25 | 3.20 | 2.85 | 26 |
| 28 | | 2.90 | 2.95 | 2.95 | 2.95 | 2.95 | 2.95 | 3.00 | 2.80 | 28 |
| 30 | | 2.50 | 2.55 | 2.55 | 2.60 | 2.65 | 2.65 | 2.60 | 2.70 | 30 |
| 32 | | 2.20 | 2.25 | 2.25 | 2.25 | 2.35 | 2.35 | 2.30 | 2.30 | 32 |
| 34 | | 1.65 | 1.75 | 1.75 | 1.85 | 1.80 | 1.90 | 1.95 | 2.05 | 34 |

Note: The shaded area is determined by the boom strength.

Load Chart of FJ Configuration**SCE600A Crawler Crane – FJ Load Chart 7/8**

| Jib Length (m) R(m) | SCE600A Crawler Crane – FJ Load Chart 7/8 | | | | | | | | | | Jib Length (m) R(m) |
|------------------------|---|-----------|-----------|-------------|-------------|------|-------|-------------|-------------|--|------------------------|
| | 6.1 | | 9.15 | | 12.2 | | 15.25 | | Jib angle | | |
| | 10° | 30° | 10° | 30° | 10° | 30° | 10° | 30° | | | |
| 12 | 7.00 | 13.6m × 6 | 12.9m × 7 | | | | | | | | 12 |
| 14 | 7.00 | 6.00 | 7.00 | 15.6m × 4.8 | 14.8m × 4.5 | | | 15.2m × 3.5 | | | 14 |
| 16 | 6.50 | 5.50 | 6.50 | 4.50 | 4.50 | | | 3.50 | | | 16 |
| 18 | 5.50 | 5.50 | 5.50 | 4.50 | 4.35 | 4.00 | | 3.45 | 19.7m × 3.2 | | 18 |
| 20 | 4.50 | 4.55 | 4.55 | 4.35 | 4.20 | 3.85 | | 3.35 | 3.20 | | 20 |
| 22 | 4.00 | 4.05 | 4.05 | 4.15 | 4.05 | 3.70 | | 3.25 | 3.10 | | 22 |
| 24 | 3.60 | 3.65 | 3.65 | 3.70 | 3.55 | 3.50 | | 3.15 | 3.00 | | 24 |
| 26 | 3.15 | 3.20 | 3.20 | 3.25 | 3.15 | 3.35 | | 3.00 | 2.90 | | 26 |
| 28 | 2.80 | 2.85 | 2.85 | 2.85 | 2.85 | 2.85 | | 2.75 | 2.80 | | 28 |
| 30 | 2.45 | 2.50 | 2.50 | 2.55 | 2.45 | 2.55 | | 2.45 | 2.55 | | 30 |
| 32 | 2.10 | 2.15 | 2.15 | 2.25 | 2.15 | 2.25 | | 2.15 | 2.30 | | 32 |
| 34 | 1.85 | 1.90 | 1.90 | 1.95 | 1.85 | 1.95 | | 1.95 | 2.05 | | 34 |

Note: The shaded area is determined by the boom strength.

Unit: t

Load Chart of FJ Configuration

| SCE600A Crawler Crane – FJ Load Chart 8/8 | | | | | | | | | | |
|---|-----------|-----------|-----------|-----------------------|-------------|------------------------|-------------|-------------|-------------|----------------|
| | | Boom 43m | | Fixed jib 6.1m-15.25m | | Rear counterweight 16t | | | | |
| Jib Length (m) | | 6.10 | | 9.15 | | 12.20 | | 15.25 | | Jib Length (m) |
| R(m) | Jib angle | 10° | 30° | 10° | 30° | 10° | 30° | 10° | 30° | Jib angle |
| | | | | | | | | | | R(m) |
| 12 | | 12.4m × 7 | | 13.5m × 7 | | | | | | 12 |
| 14 | 7.00 | | 14.2m × 6 | 7.00 | | 14.7m × 4.5 | | 15.8m × 3.5 | | 14 |
| 16 | 7.00 | | 5.50 | 6.50 | 16.2m × 4.8 | 4.50 | | 16.8m × 3.5 | | 16 |
| 18 | 5.50 | | 5.50 | 5.50 | 4.80 | 4.35 | 19.3m × 3.8 | 3.35 | | 18 |
| 20 | 4.45 | | 4.50 | 4.50 | 4.50 | 4.20 | 3.80 | 3.25 | 20.3m × 3.2 | 20 |
| 22 | 3.95 | | 4.00 | 4.00 | 4.20 | 4.05 | 3.70 | 3.15 | 3.15 | 22 |
| 24 | 3.50 | | 3.55 | 3.55 | 3.65 | 3.55 | 3.50 | 3.05 | 3.05 | 24 |
| 26 | 3.10 | | 3.15 | 3.15 | 3.15 | 3.10 | 3.20 | 2.85 | 2.95 | 26 |
| 28 | 2.70 | | 2.75 | 2.75 | 2.75 | 2.75 | 2.85 | 2.75 | 2.85 | 28 |
| 30 | 2.40 | | 2.45 | 2.45 | 2.35 | 2.35 | 2.50 | 2.40 | 2.55 | 30 |
| 32 | 2.00 | | 2.05 | 2.05 | 2.10 | 2.05 | 2.15 | 2.05 | 2.25 | 32 |
| 34 | 1.70 | | 1.75 | 1.75 | 1.85 | 1.75 | 1.90 | 1.75 | 2.05 | 34 |

Note: The shaded area is determined by the boom strength.

Notes: Rated capacity of crawler crane

- ① The rated capacity in the load charts is calculated when the crane is parking on firm and level ground, lifting the load slowly and steadily.
- ② The shaded values are determined by strength.
- ③ The rated capacity values in the load charts are only valid when wind speed is lower than 9.8m/s.
- ④ The rated capacity in the load charts includes the weight of hook, wire rope and other riggings; therefore, the actual rated capacity shall deduct the weight of these components.
- ⑤ The crawlers must be extended during lifting.
- ⑥ The values in the load charts are valid for 360° swing.



Zhejiang SANY Equipment Co., Ltd.

SANY Industrial Park, No. 2087 Daishan Road, Wuxing District, Huzhou City,
Zhejiang Province, P. R. of China Zip 313028

After-sales Service 400 887 8318

Consulting 400 887 9318

— Agent information —

Due to updated technology, the technical parameters and configurations are subject to change without prior notice. The machine in the picture may include additional equipment. This album is for reference only, subject to the object.

All rights reserved for Sany, without the written permission of Sany, the contents of any part of this content shall not be copied or copied for any purpose.

© Printed in June 2019 in China

www.sany.com.cn



Please scan the official
WeChat account of Sany
for more information.

Courtesy of CraneMarket.com