

SAC3500S

SANY All Terrain Crane
350 Tons Lifting Capacity



Max. Lifting Capacity: 350 t
Max. Boom Length: 70 m
Max. Lifting Height: 136 m

Excellent Performance

- The crane layout is more compact and reasonable, the design of key structural parts is more optimized, and the lifting performance is leading among products of the same tonnage in the industry.
- Fully extended boom is 70 m long, fixed jib is 6~42 m long, and tower jib is 12~78 m long; the maximum load moment of the basic boom is 1152 t.m, the maximum lifting height is 136 m, and the maximum working radius is 96 m. It is convenient to switch among different working conditions and has high working efficiency.
- Innovative six-axle chassis design, multiple braking modes and suspension modes, more reliable and comfortable chassis driving performance.
- The self-developed double pump combined/shunt technology can achieve both high efficiency and good maneuverability.

High Quality

- Adopt the advanced single-cylinder pin-type telescopic boom technology, the cylinder boom pin is interlocked in combination with mechanical, electrical and hydraulic protection with higher reliability.
- Adopt the original closed slewing buffer system, to realize more stable slewing startup and brake and more excellent micro-mobility.
- Adopt the self-developed double pump combined/shunt technology, the confluence efficiency of single-acting double pumps is higher, and the shunting operation of combined-acting dual pumps is better.
- Electric proportional variable plunger pump is adopted to realize high-precision flow control and high efficiency energy saving.
- Adopt international advanced distributed integrated bus data communication network. It is equipped with rich sensor pieces to timely feedback the data information so as to achieve real-time monitoring on the working status of the crane at any time.
- Multifunctional wireless remote control system makes crane operation more convenient. Safety protection program and fault judgment system ensure safe and reliable operation.
- Customers can set the maneuverability of the crane by themselves through the first human-machine interaction interface in China according to their personal operating habits and different use conditions to meet their personalized needs.
- Adopt the international advanced hydro-pneumatic suspension technology to adapt to various bad road conditions, with better trafficability and more comfortable driving.
- Adopt the streamlined full-width cab and variable-position panoramic skylight operation cabin to make vision wider and operation more comfortable.
- Widely apply the advanced manufacturing technology to ensure each process to keep improving and effectively ensure the excellent performance of the products.



Energy conservation and environment protection

- The weight of the crane is optimally configured. The structure of the crane is reasonable and compact. It consumes 100 L oil per hundred kilometers and has strong oil-saving capability.
- Adopt the electric proportional pump, of which displacement and speed can be controlled by different gears, saving energy by 20%.
- Adopt the first double pump combined/shunt intelligent speed regulation technology in China to meet the needs of various action combinations and save energy with high efficiency.

Safety and Reliability

- It is equipped with anti-rollover early-warning system to ensure the safety of crane operation through the early warning prompt given by the sound and light.
- It is equipped with a voice alarm system to give voice prompts for various actions to prevent misoperation and give a prompt and an alarm to the staff around, thus ensuring the safety of crane operation and staff.
- Adopt the torque limiter system with high precision, stability and intelligence to protect the lifting operation in all directions.
- It is equipped with rich sensor pieces to timely feedback the data information, achieve real-time monitoring and master the working status of the crane at any time.

GCP system

- The first remote monitoring and management system for equipment at home has a powerful acquisition function for equipment operation condition and operation parameters, and can diagnose and manage remote faults.
- Customers can master the operation of equipment as well as the query and ordering of accessories at home.



Overall Dimensions

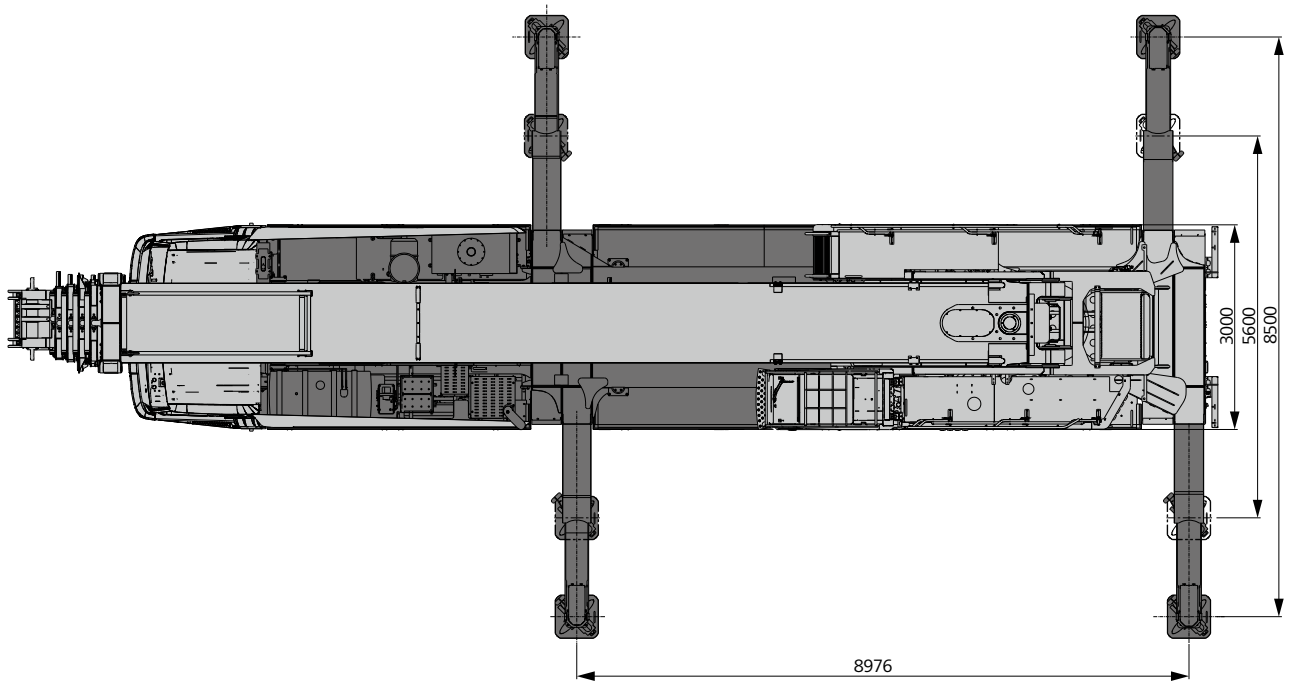
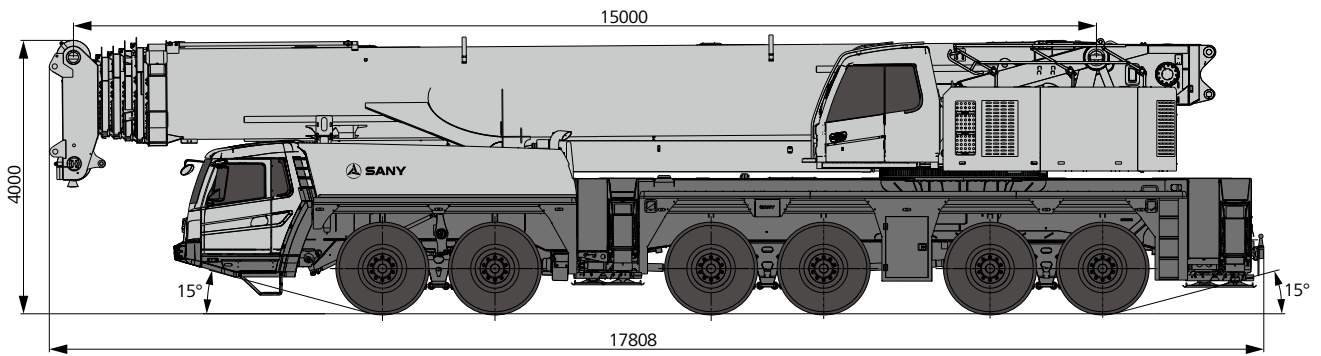

Technical Parameters

Type	Item	Parameter	
Capacity	Max. lifting capacity	350 t	
Dimension	Full length of the crane	17808 mm	
	Full width of the crane	3000 mm	
	Full height of the crane	4000 mm	
	Axle base	No. 1 and 2 wheel bases	1650 mm
		No. 2 and 3 wheel bases	3170 mm
		No. 3 and 4 wheel bases	1650 mm
No. 4 and 5 wheel bases		2440 mm	
Distance between No. 5 and No. 6 axles		1650 mm	
Weight	Gross mass of the crane	72000 kg	
	Load	No. 1, 2 and 3 axle load	12000 kg
		Load of No. 4, No. 5 and No. 6 axles	12000 kg
Power (substructure)	Rated power	480kw/1800rpm	
	Maximum torque	3000N.m/1300rpm	
Power (superstructure)	Rated power	205kw/2200rpm	
	Maximum torque	1100N.m/1200~1600rpm	
Running parameters	Maximum running speed	80 km/h	
	turning radius	Minimum turning radius	11.68 m
		Minimum turning radius of boom head	14.4 m
	Wheel mode	12×8	
	Minimum ground clearance	360 mm	
	Approach angle	15°	
	Departure angle	15°	
	Maximum gradient	49%	
Fuel consumption per 100 km	≤ 100		
Main performance parameters	Operating temperature interval	-20~+40 °C	
	Minimum rated range	3 m	
	Turning radius at tail of slewing table	5.74 m	
	Number of boom section	6	
	Boom shape	U boom	
	Maximum lifting moment	Basic boom	11520 kN·m
		Full-extended boom	8180 kN·m
		Longest boom + longest fixed jib	1995 kN·m
		Longest boom + longest tower jib	1768 kN·m
	Boom length	Basic boom	15.2 m
		Full-extended boom	70 m
		Longest boom + longest fixed jib	65.6 m+2.5 m+42 m
		Longest boom + longest tower jib	55.5 m+7 m+78 m
Outrigger span (longitudinal × transverse)	8.95 m×8.5 m		
Installation angle of jib	0°/20°/40°		
Operating speed parameters	Maximum lifting speed of single rope of main winch (no load)	120m/min	
	Maximum lifting speed of single rope of tower boom winch (no load)	120m/min	
	Full extension and retraction time of boom (Autostretch)	720s	
	Full rising/falling time of lifting boom	75/110s	
	Slewing speed	1.2 r/min	
Air conditioner	Superstructure air-conditioner	Heating and cooling	
	Substructure air-conditioner	Heating and cooling	

**Axle load**

Axle	1	2	3	4	5	6	Overall mass
Axle load / t	12	12	12	12	12	12	72
Note	It does not include hooks, counterweights and accessories for superlift.						

**Hook and multiplying power**

Rated load/t	Pulleys	Number of parts of line	Hook weight/kg	Note
160	7	14	1627	Optional counterweight
80	3	7	723	Optional counterweight
32	1	3	521	Optional counterweight
12.5	0	1	526	Auxiliary hook

Crane Introduction

No	Name	Manufacture
1	Chassis Engine	Benz
2	Superstructure engine	Benz
3	Axle 1	KESSLER
4	Axle 2	KESSLER
5	Axle 3	KESSLER
6	Axle 4	KESSLER
7	Axle 5	KESSLER
8	Axle 6	KESSLER
9	Transmission	ZF
10	Transfer case	KESSLER
11	Main lifting piston pump	Danfoss
12	Luffing piston pump	Rexroth
13	Telescoping piston pump	Rexroth
14	Telesoping balance valve	WESSEL

Crane Introduction

Control room

- A fully welded structure formed by stamping is adopted, safety glass is installed, the train window is provided with a sunshade curtain, the door is opened outwards, and a control lever is installed on a control box, which conforms to the ergonomics principle. Anti-corrosion glass fiber reinforced plastics reinforced composite structure, full coverage and softening interior decoration, panoramic skylight, inclinable positioning of operator's seat back and other humanized designs make the operation comfortable and easy. Touch display screen with adjustable viewing angle, multi-picture and multi-angle monitoring is used to ensure safe operation and meet one-touch operation. Monitors shall be provided for the main boom and tower booms and superlift winch, with centralized monitoring in key areas. The main console is organically combined with the operation display system, and the human-computer interaction is convenient and quick. The control room can be tilted upward by 20 degrees to meet the needs of high-altitude operation observation, and is equipped with air conditioner.

Engine

- Model: Mercedes OM906LA.E3A/1, electrically controlled, in-line six-cylinder, water cooling, supercharged and mid-cooling, diesel engine.
- Power: 205 kw/2,200 r/min.
- Maximum torque: 1,200 Nm/1,200-1,600 rpm.
- Environmental protection: The emission conforms to European III standard.
- Effective volume of fuel tank: 300 L.

Boom system

- **Main cargo boom:** It consists of 1 basic boom and 5 telescopic booms, and is bent and welded of fine-grained high-strength steel with oval section and good buckling resistance. Single cylinder automatic pin-type system is used. A double-acting oil cylinder can control the extension and retraction of all booms to achieve various boom length combinations. The basic boom is 15 m long and the full extension boom is 70 m long.
- **Cargo jib:** There are two types, namely, fixed jibs and tower jibs: Fixed jibs and tower jibs share adapter, jib heads, and 6 m and 12 m large (small) section standard joints, thus realizing boom length combination of 6 m to 42 m, and the angles can be changed according to actual needs of working conditions, thus improving automation level, reducing labor intensity and improving working efficiency. The tower jib can realize the boom length combination of 12 m to 78 m, greatly improving the lifting capacity and the working height.
- **Superlift device:** It is arranged on the left and right sides of the head of the basic boom and is independent on both sides, thus realizing self-assembly and disassembly without auxiliary hoisting. The superlift device greatly improves the stress status of the lifting boom, avoids side bending, reduces the downwarping deformation of the lifting boom, reduces the deflection of the lifting boom by 20%-30% in the long boom state, and improves the lifting performance by more than 200%.

Slewing System

- It is composed of a constant displacement motor and a swing reducer, which are mature in technology and widely used in truck cranes. At the same time, the superlift device is externally meshed with a swing bearing to realize full swing by 360°, and the swing speed can be continuously adjusted from 0-1.2 rpm. A closed swing hydraulic system is used to avoid throttling loss of open system and improve the efficiency of the system. Electric proportional brake pedal is used to realize emergency braking.

Hydraulic system

- The opening and closing combined independent hydraulic system of superstructure has the characteristics of load sensitivity, heavy load and low speed, light load and high speed, and high operation efficiency. The derricking telescopic system adopts an open system consisting of electric proportional pump and self-made main valve, and has four-stage pressure selection function. Different actions adopt different pressure levels and cooperate with the displacement of electric proportional pump, thus realizing energy-saving and safe derricking and telescopic actions. The hoisting winch system adopts closed system to avoid throttling loss of the open system, so that the system has higher efficiency and wide speed regulation range. The closed system is adopted for slewing to avoid throttling loss of the open system, so that the system has higher efficiency and good micro-motion. In addition to the functions of superstructure slewing, boom derricking, stretching, raising and lifting the main and auxiliary winches, it can also realize the functions of counterweight lifting, control room rotating and turntable locking.
- Adopt high-quality components such as main oil pump, slewing pump, winch motor and balance valve to ensure high reliability. Electric proportional variable displacement piston pump is used to adjust displacement of oil pump in real time, so as to realize high-precision flow control and minimize energy dissipation. By using the dual-pump combined/shunt main valve researched and developed independently, the confluence efficiency of single-acting double pumps is high and the shunting controllability of combined-acting double pump is good.
- Adopt the dead-weight derricking compensating hydraulic system to realize excellent micro-mobility and stability of derricking.
- Single-cylinder pin-type rapid telescopic system is used for extension and retraction of boom.
- Capacity of hydraulic oil tank: 1290 L.

Crane Introduction



Lifting System

- Main lifting mechanism: hydraulic motor-driven planetary gear reducer, special rope groove winding drum and built-in brake.
- Wire rope lock: High quality wire rope lock is applied. The wire rope end is casted and directly installed in the lock sleeve, which improves the lifting rate of the replacement speed and is convenient and efficient.
- Wire rope specification: ϕ 24-2,160, non-rotating wire rope;
- Length of steel wire rope: about 400 m;
- Maximum single rope speed (the forth layer): about 120 m/min.
- Hoisting mechanism of tower boom: hydraulic motor-driven planetary gear reducer, special rope groove winding drum and built-in brake; anti-winding wire rope. It can be operated separately from the auxiliary hoisting mechanism.
- Wire rope specification: ϕ 24-2160, non-rotating wire rope;
- Length of steel wire rope: about 640m;
- Maximum single rope speed (the forth layer): about 120 m/min.



Derricking System

- For single-cylinder front-top derricking with derricking angle of $-0.4^{\circ}\sim 82^{\circ}$, the hydraulic system uses double-pump confluence open hydraulic circuit, and combines electric proportional control, power derricking down and dead-weight derricking down to realize large-angle fast derricking down and small-angle stable and slow derricking down.



Control System

- It is powered by 24V DC power supply. PLC integrated programmable controller and CAN-BUS control network are used in combination with conventional electricity to realize the logic control and electric proportional control of the system;
- It supports real-time system monitoring and automatic fault diagnosis;
- Lifting, swing and derricking are controlled proportionally by two automatic resetting and multi-directional electric proportional handles. The extending and retracting are controlled by treadle type telescopic pedal. The lifting of counterweight, the dislocation of control cabin and the locking of rotary table are all controlled by keys on the control panel;
- The display is connected with the controller by CAN bus. Its main functions are: digital adjustment and display of electric proportional control parameters; fault code display of electric proportional system; display of real-time detection data of hydraulic system.



Safety device

- A moment limiter calculation system based on gravity model is established with the method of analysis mechanics, and the loading accuracy reaches $\pm 3\%$ through online no-load calibration.
- Hydraulic balance valve, overflow valve, two-way hydraulic lock and other components are provided for hydraulic system to realize stable and reliable hydraulic system;
- Three-circle protector is equipped for main winch and tower boom winch to avoid overfall of wire rope;
- Height limiters are equipped for boom and jib ends to avoid overwind of wire rope.
- Boom end is equipped with anemometer to detect whether high-altitude wind speed exceeds the allowable range for operation.
- Superlift rope extension and retraction protection procedures, tower (jib) boom installation, hoisting protection procedures, etc.



Counterweight

- Combined variable counterweight is adopted. There are 7 combinations, namely, 0 t, 14 t, 28.5 t, 43 t, 56 t, 80 t, 100 t, which can meet the needs of different working conditions, maximize the performance of structural members, can be detached and installed by remote control, and has good micro-motion.

Crane Introduction

Cab

- With new steel structure researched and developed independently by SANY, excellent shock absorption property and sealing performance, outward opening type doors at two sides, driver's seat and assistant driver's seat of pneumatic suspension, adjustable steering wheel, rear-view mirror with wide view, comfortable driving chair with headrest, fog-resistance fan, air conditioner, stereo radio and other devices, and complete control equipment and instrument, the cab is more comfortable, safe and humanized.

Frame

- SANY adheres to independent development and is specialized in manufacturing anti-torsion box structure with optimized structure and light weight, as well as welding and manufacturing of fine-grained high-strength steel; the supporting leg is contracted in a special fixing box, and is positioned between No. 2 and No. 3 axles and at the rear of the frame; and equipped with front and rear traction hooks.

Chassis engine

- Type: electronic control, V-shaped eight-cylinder, water cooling, supercharging and inter-cooling, electric injection and diesel engine;
- Rated power: 480 kW/1800 rpm;
- Maximum torque: 3000 Nm/1300 rpm;
- Environmental protection: Emissions meet Euro V standards;
- Fuel tank capacity: about 550 L.

Transmission

- Manual/automatic transmission has 12 gears with a wide speed ratio range, which can meet the requirements of climbing at low speed and driving at high speed on the site.

Axle

- The disc brakes are imported with original packaging of German Kessler. For steering of the whole axles, No. 1, No. 3, No. 5 and No. 6 axles are driving axles, of which No. 6 axle is equipped with disengaging device, No. 3 axle is used for normal road driving, and the fourth bridge is used for complex road driving. No. 1 and 2 axles are subject to hydraulic power steering system fed back by rod system, No. 3 - No. 6 axles are subject to electro-hydraulic control steering, which can assist in speed control and choose special steering mode, with easy steering and flexible control.

Drive/Steering

- 12x8

Tire

- 12 tires - 14.00R25 (385/95 R25) or 16.00R25 (445/95 R25)

Suspension System

- All axle suspension devices are hydro-pneumatic suspension technology devices with adjustable height and hydraulic locking. The suspension cylinder travel is +160/-130 mm and can achieve five modes: suspension, rigid locking, automatic leveling, complete vehicle lifting, and single-point lifting. Each root bridge load is equal, not higher than 12 t. The trafficability is good, which can be applied to various bad working conditions and road surfaces, ensuring the smoothness and rollover stability of cranes and comfortable driving.

Brake system

- Dual-circuit air brake, equipped with disc brakes.
- Driving braking: All wheels are equipped with air servo brake, dual-circuit brake system, and drum brake.
- Parking braking: Driven by the accumulator, it acts on No. 2 - No. 6 axles.
- Auxiliary brake: The engine is equipped with engine brake, exhaust brake and transmission hydraulic retarder brake.

Steering System

- It is equipped with servo power steering gear, dual-circuit system hydraulic steering device and emergency steering pump. The steering strategy is adjusted according to the speed. If the speed starts from 30 km/h, No. 3 and No. 4 axles do not turn; if the speed starts from 60 km/h, No. 5 and No. 6 axles do not turn.

Outrigger

- Brakes system includes traveling brake, parking brake, emergency brake, and auxiliary brake.
- Traveling brake: All wheels use the air servo brakes and dual-circuit brake system and are equipped with disk brakes.
- Parking brake: Force driven by accumulator is applied on the second to sixth axle.
- Emergency brake: Accumulator is used not only for cutting-off brake but also for emergency brake.
- Auxiliary brake consists of engine brake and exhaust brake etc. There are double brakes for the engine, hydraulic power retarder brake for reducer and eddy current retarder brake for four axle which ensure high safety and reliability of the travelling.

Electrical System

- Axle suspension devices adopt the height-adjustable oil-gas suspension devices equipped with the hydraulic lock, with stroke of suspension cylinder of +160/-130mm to achieve suspension, rigid locking, automatic leveling, overall lifting and lowering, single-point lifting and lowering modes. Load applied on each axle is no more than 12t. With good trafficability and adaptability of a variety of severe operating conditions and road, smooth and comfortable travelling and side stability of the vehicle are guaranteed.

Boom Operating Range

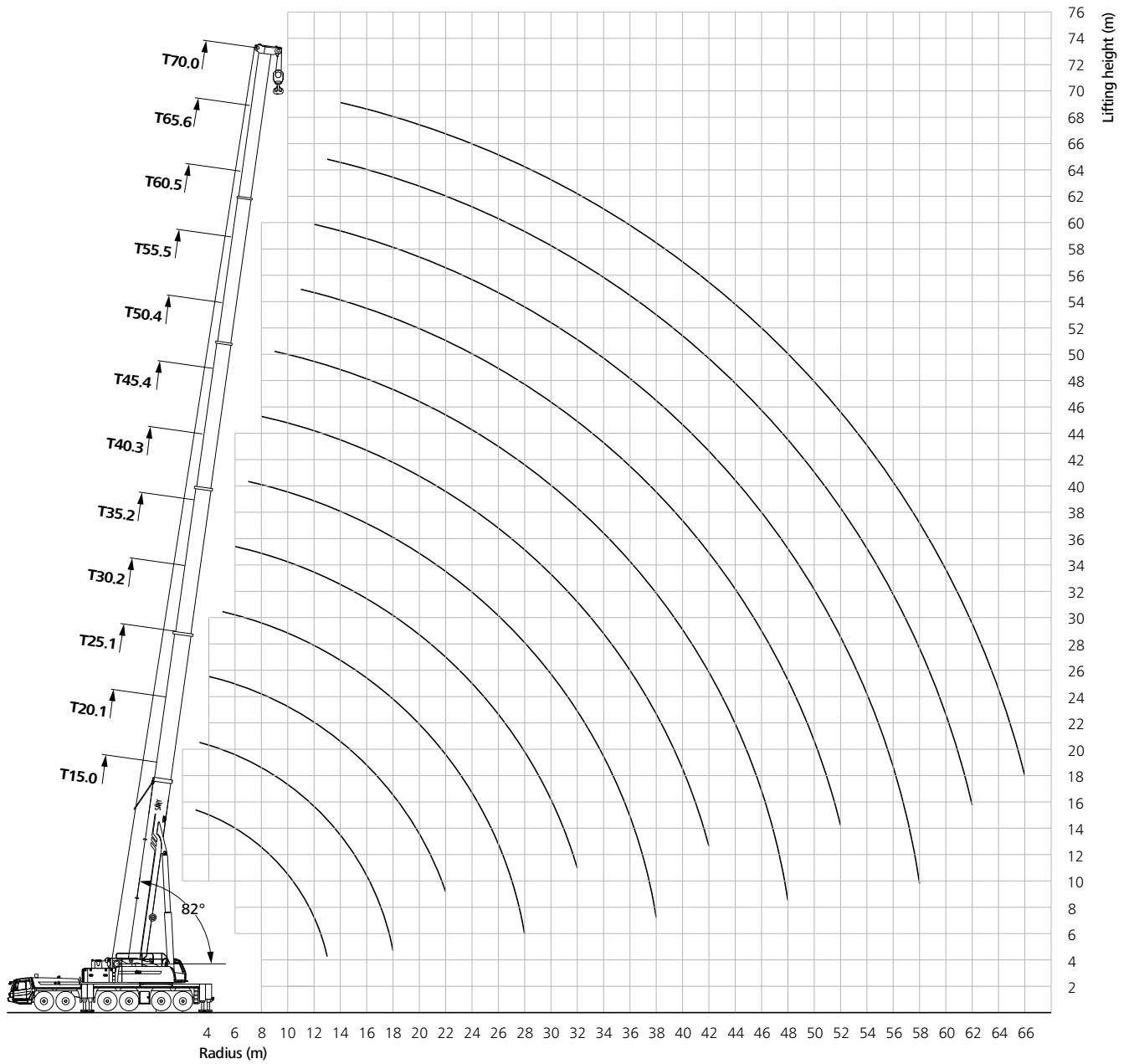

Load Chart - Telescopic Boom

Unit: t

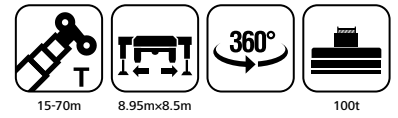

Amplitude	15m*	15m	20.1m	25.1m	30.2m	35.2m	40.3m	45.4m	50.4m	55.5m	60.5m	65.6m	70m	Amplitude
3	350.0	175.0												3
3.5	260.0	172.0	165.0											3.5
4	235.0	170.0	164.0	162.3										4
4.5	215.0	165.5	163.0	162.0	135.0									4.5
5	198.0	156.0	161.4	159.7	125.0									5
6	175.0	143.5	142.8	143.1	120.0	95.0								6
7	157.0	128.6	127.8	128.1	118.0	91.0	85.5							7
8	142.0	116.3	115.5	115.8	113.5	90.0	83.0	61.0						8
9	128.0	102.5	105.2	105.5	105.6	89.0	81.5	58.0	53.6					9
10	112.0	97.2	96.4	96.7	95.8	87.0	77.6	54.0	50.0					10
11	98.0	88.8	88.3	88.7	87.5	84.5	74.0	50.0	46.5	38.5				11
12	86.0	75.8	80.3	80.7	80.2	78.0	69.4	47.5	43.0	37.0	29.3			12
13	57.5	57.5	73.5	73.9	73.4	74.0	65.6	44.1	38.2	32.7	27.9	24.5		13
14			67.6	68.0	68.8	66.5	62.6	41.3	36.6	31.1	27.0	23.3	18.0	14
16			58.0	58.4	59.2	55.3	55.8	37.2	33.0	29.7	25.0	22.5	18.0	16
18			39.0	50.9	51.6	48.4	49.6	34.0	30.5	27.4	23.0	21.5	18.0	18
20				44.8	45.6	42.9	45.0	31.5	28.0	25.3	21.5	20.8	16.7	20
22				39.6	40.6	39.0	40.8	29.2	26.0	23.4	20.0	19.8	16.1	22
24					36.0	34.9	37.2	27.5	24.0	21.6	18.0	18.7	15.8	24
26					31.3	31.2	32.9	25.7	22.0	19.9	17.0	17.9	15.6	26
28					22.6	28.1	29.4	24.2	20.0	18.5	16.5	16.7	15.4	28
30						25.5	26.4	22.7	18.6	17.1	15.3	16.0	14.7	30
32						23.1	23.9	21.8	17.4	15.8	14.5	15.3	14.0	32
34							21.6	20.3	16.3	14.6	13.3	14.2	13.3	34
36							19.6	19.0	15.3	13.6	12.4	13.7	12.5	36
38							13.0	17.8	14.6	12.7	11.9	12.8	11.9	38
40								16.3	13.9	12.0	11.3	12.1	11.4	40
42								14.8	13.2	11.0	10.6	11.7	10.6	42
44									12.8	10.5	10.1	11.2	10.1	44
46									12.2	10.0	9.6	10.6	9.5	46
48									9.2	9.8	9.2	10.0	8.8	48
50										9.2	8.8	9.5	8.2	50
52										8.9	8.5	9.0	7.6	52
54											7.9	8.5	7.0	54
56											7.7	8.0	6.5	56
58											6.2	7.5	6.0	58
60												7.0	5.6	60
62												6.5	5.2	62
64													4.8	64
66													4.4	66
n		14	13	13	10	8	6	5	4	3	3	2	2	n
Wind speed	9.0	9.0	9.0	9.0	9.0	9.0	9.0	9.0	9.0	9.0	9.0	9.0	9.0	Wind speed

Note: *Auxiliary devices shall be added to operate right aft. **Special customized additional device is required.
 The values given in the table are rated load lifting capacities of crane when the crane is leveled on the flat and hard ground;
 The given value in the table is the maximum value of corresponding boom length and different arm extension modes.
 The rated load lifting capacity in the table includes the weights of main hook and sling.
 If the actual amplitude is within the two values in the table, the lifting capacity for operation shall be determined by the larger value.

Boom With Superlift Operating Range

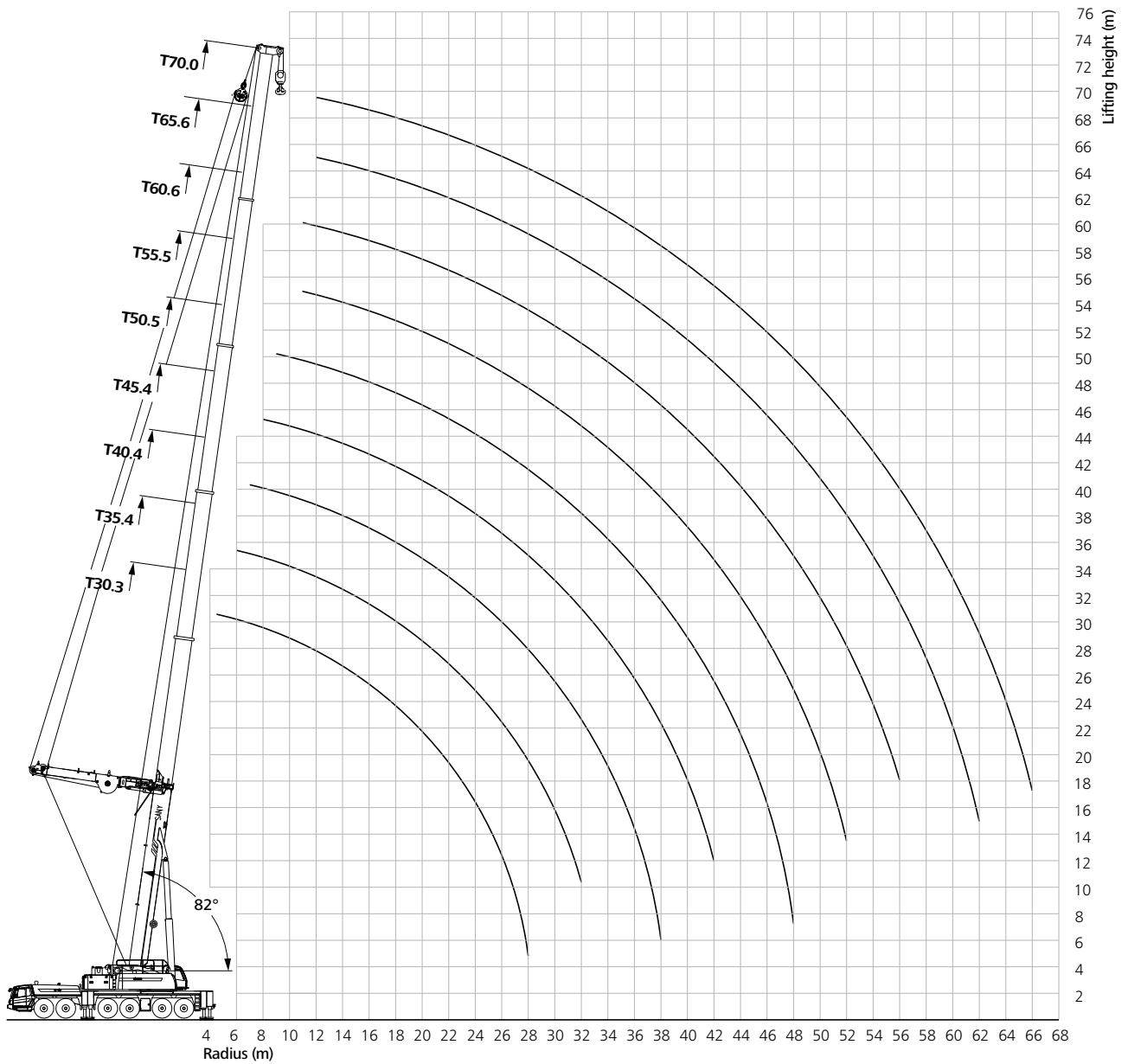

Load Chart - Boom With Superlift

Unit: t

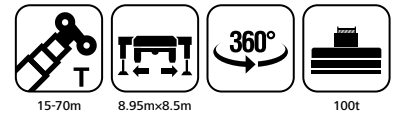

Amplitude	30.2m	35.2m	40.3m	45.4m	50.4m	55.5m	60.5m	65.6m	70m	Amplitude
4.5	115.0									4.5
5	115.0									5
6	114.0	105.0								6
7	113.0	103.0	100.0							7
8	112.0	101.2	95.0	80.0						8
9	102.3	99.0	92.0	78.0	75.0					9
10	91.9	93.0	85.0	76.5	74.5					10
11	85.2	85.0	82.0	75.0	71.6	65.0	58.0			11
12	80.3	80.0	79.0	73.5	68.2	63.0	57.0	45.0	37.0	12
13	73.3	74.5	76.0	69.0	65.6	61.1	56.0	44.5	36.5	13
14	67.1	68.8	67.9	68.0	63.0	60.5	55.0	44.0	36.0	14
16	56.9	58.7	60.3	60.2	58.4	56.5	54.0	43.0	35.5	16
18	48.9	50.7	52.3	52.2	52.6	53.1	52.0	42.0	35.0	18
20	42.5	44.3	45.9	45.8	46.2	46.8	47.4	41.0	34.5	20
22	37.1	39.0	40.6	40.6	40.9	41.5	42.2	40.0	34.0	22
24	32.6	34.6	36.2	36.2	36.5	37.1	37.6	37.2	33.0	24
26	28.7	30.3	31.8	32.4	32.8	33.4	33.1	32.6	32.1	26
28	20.8	26.3	27.9	29.2	29.6	29.6	29.3	28.8	29.0	28
30		22.9	24.6	26.0	26.3	26.4	26.0	25.6	25.8	30
32		19.9	21.7	23.2	23.5	23.6	23.3	22.9	23.0	32
34			19.2	20.7	21.1	21.2	20.9	20.4	20.6	34
36			16.9	18.5	18.9	19.0	18.7	18.3	18.5	36
38			13.1	16.6	17.0	17.1	16.9	16.5	16.7	38
40				14.8	15.3	15.4	15.2	14.8	15.0	40
42				13.1	13.7	13.9	13.7	13.3	13.5	42
44					12.3	12.5	12.3	12.0	12.2	44
46					11.0	11.3	11.1	10.7	10.9	46
48					9.0	10.1	9.9	9.6	9.8	48
50						9.0	8.9	8.6	8.8	50
52						7.9	7.9	7.6	7.9	52
54							7.0	6.7	7.0	54
56							6.1	5.9	6.2	56
58								5.1	5.4	58
60								4.4	4.7	60
62								3.6	4.0	62
64									3.4	64
66									2.7	66
n	10.0	9.0	7.0	6.0	5.0	5.0	5.0	4.0	3.0	n
Wind speed	9.0	9.0	9.0	9.0	9.0	9.0	9.0	9.0	9.0	Wind speed

Note: The values given in the table are rated load lifting capacities of crane when the crane is leveled on the flat and hard ground;
The given value in the table is the maximum value of corresponding boom length and different arm extension modes.
The rated load lifting capacity in the table includes the weights of main hook and sling.
If the actual amplitude is within the two values in the table, the lifting capacity for operation shall be determined by the larger value.

Fixed jib Operating Range

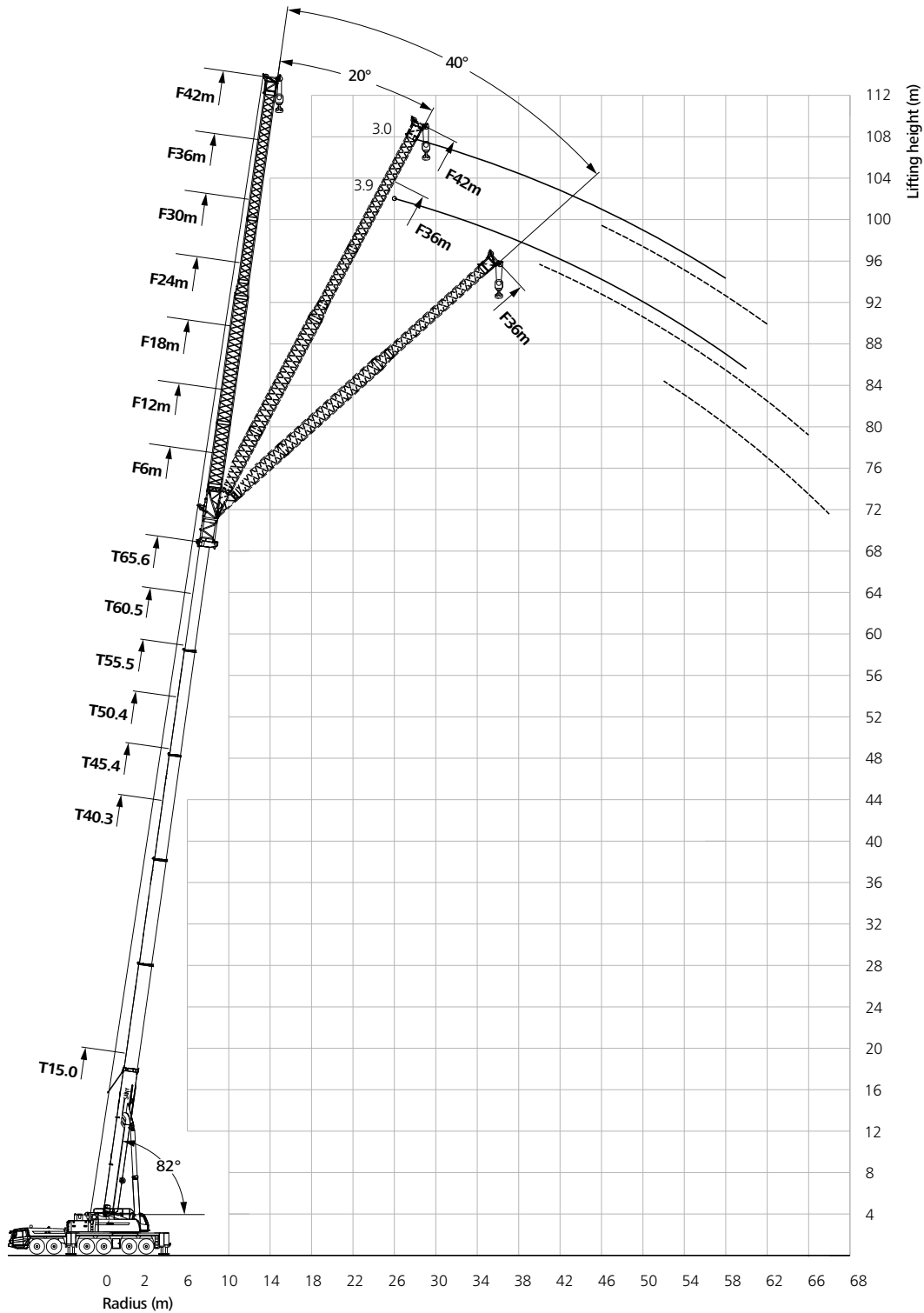

Load Chart - Fixed Jib

Unit: t

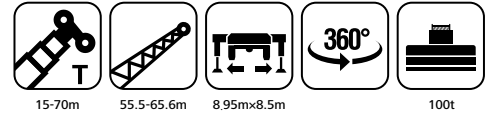

Working radius(m)	55.5m						60.6m						65.6m						Working radius (m)				
	12m	18m	24m	30m	36m	42m	6m	12m	18m	24m	30m	36m	42m	6m	12m	18m	24m	30m		36m	42m		
16	17.6						17.3															16	
18	16.7	14.4					16.4	13.8	11.0						13.8								18
20	15.6	13.7	11.0	7.6			15.3	13.2	10.8	9.1					13.1	10.9	8.7						20
22	14.6	13.0	10.7	7.3	6.2		14.2	12.5	10.5	8.9	6.8				12.4	10.5	8.5	7.0					22
24	13.7	12.2	10.1	7.1	6.0	5.3	13.3	11.8	10.1	8.4	6.7	5.5			11.7	10.0	8.2	6.7	5.1				24
26	12.8	11.5	9.3	6.7	5.8	5.1	12.4	11.1	9.6	7.8	6.5	5.3	4.5		11.0	9.5	7.9	6.3	5.0	3.9			26
28	11.9	10.8	8.5	6.5	5.6	4.9	11.5	10.4	9.1	7.1	6.2	5.2	4.4		10.3	9.0	7.6	5.7	4.8	3.8	3.0		28
30	11.1	10.1	7.7	6.2	5.3	4.7	10.7	9.7	8.6	6.4	6.0	5.0	4.2		9.6	8.5	7.3	5.2	4.7	3.7	3.0		30
32	10.4	9.5	7.2	6.0	5.1	4.5	10.0	9.1	8.2	6.0	5.8	4.8	4.0		9.0	8.0	7.0	5.0	4.5	3.7	2.9		32
34	9.7	8.9	6.8	5.7	4.9	4.3	9.3	8.5	7.7	5.8	5.5	4.8	3.9		8.4	7.5	6.6	4.8	4.3	3.6	2.8		34
36	9.1	8.3	6.4	5.4	4.7	4.1	8.7	7.9	7.2	5.4	5.2	4.6	3.7		7.8	7.1	6.3	4.6	4.1	3.4	2.8		36
38	8.4	7.8	6.0	5.2	4.4	4.0	8.0	7.4	6.8	5.1	4.9	4.4	3.6		7.3	6.6	6.0	4.3	3.9	3.2	2.7		38
40	7.8	7.3	5.6	4.9	4.2	3.8	7.4	6.9	6.3	4.8	4.7	4.2	3.5		6.8	6.2	5.6	4.1	3.8	3.1	2.6		40
42	7.2	6.8	5.3	4.8	4.0	3.6	6.9	6.4	5.9	4.5	4.5	3.9	3.3		6.3	5.8	5.3	3.9	3.6	2.9	2.5		42
44	6.7	6.3	4.9	4.5	3.9	3.4	6.3	6.0	5.5	4.3	4.2	3.7	3.2		5.8	5.4	4.9	3.7	3.4	2.9	2.4		44
46	6.1	5.8	4.6	4.3	3.6	3.3	5.8	5.5	5.2	3.9	3.9	3.5	3.1		5.4	5.0	4.6	3.4	3.3	2.8	2.3		46
48	5.7	5.4	4.3	3.9	3.4	3.2	5.3	5.1	4.8	3.7	3.6	3.2	2.9		5.0	4.6	4.3	3.2	3.1	2.6	2.1		48
50	5.2	5.0	4.0	3.7	3.3	3.0	4.9	4.7	4.5	3.4	3.3	3.0	2.8		4.6	4.3	4.0	3.0	2.8	2.5	2.0		50
52	4.8	4.6	3.7	3.4	3.1	2.9	4.4	4.3	4.1	3.1	3.1	2.8	2.6		4.2	3.9	3.7	2.7	2.6	2.3	1.9		52
54	4.4	4.2	3.4	3.1	2.9	2.7	4.0	3.9	3.8	2.9	2.9	2.6	2.4		3.8	3.6	3.4	2.6	2.4	2.1	1.8		54
56	4.0	3.8	3.1	2.9	2.7	2.6	3.7	3.5	3.5	2.6	2.6	2.4	2.2		3.4	3.3	3.1	2.3	2.2	1.9	1.6		56
58	3.6	3.5	2.9	2.6	2.6	2.5	3.3	3.2	3.2	2.5	2.4	2.2	2.0		3.1	3.0	2.9	2.1	2.0	1.8	1.5		58
60	3.3	3.2	2.6	2.5	2.3	2.3	3.0	2.9	2.9	2.2	2.1	1.9	1.8		2.8	2.7	2.6	2.0	1.8	1.6			60
62	3.0	2.9	2.4	2.2	2.2	2.1	2.7	2.6	2.6	2.0	2.0	1.7	1.6		2.6	2.4	2.3	1.7	1.7				62
64	2.7	2.6	2.1	2.0	1.9	1.9	2.5	2.4	2.3	1.8	1.8	1.5			2.3	2.1	2.1	1.5					64
66	2.4	2.4	2.0	1.8	1.7	1.7	1.8	2.1	2.1	1.5	1.5				2.0	1.9	1.8						66
68		2.2	1.7	1.6	1.5	1.5		1.9	1.8						1.8	1.7							68
70		1.9	1.5					1.6							1.6								70
n	2	2	1	1	1	1	2	2	1	1	1	1	1	2	1	1	1	1	1	1	1	n	
m/s	9.0	9.0	9.0	9.0	9.0	9.0	9.0	9.0	9.0	9.0	9.0	9.0	9.0	9.0	9.0	9.0	9.0	9.0	9.0	9.0	9.0	m/s	

Note: The values given in the table are rated load lifting capacities of crane when the crane is leveled on the flat and hard ground;
If the actual amplitude is within the two values in the table, the lifting capacity for operation shall be determined by the larger value.
The rated load lifting capacity in the table includes the weights of main hook and sling.

Fixed Jib With Superlift Operating Range

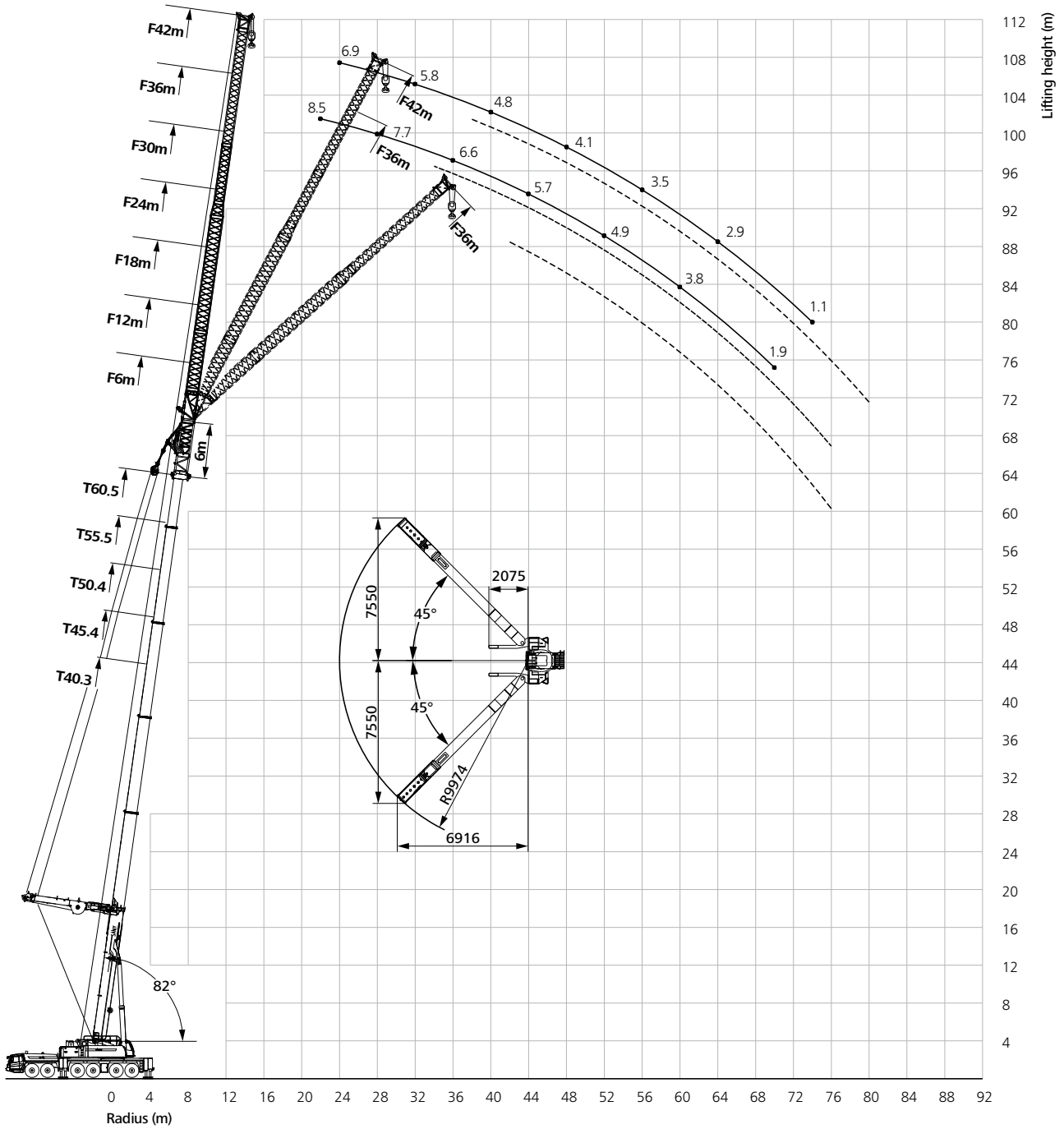

Load Chart - Fixed Jib With Superlift

Unit: t

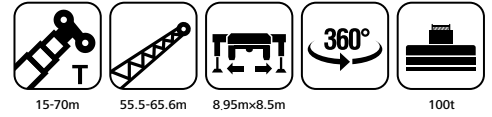

Working radius(m)	55.5m						60.6m							65.6m						Working radius(m)		
	12m	18m	24m	30m	36m	42m	6m	12m	18m	24m	30m	36m	42m	6m	12m	18m	24m	30m	36m			
14	32.1																				14	
16	30.4	22.1					31.9															16
18	28.8	20.9	16.2	12.4			31.2	28.1	20.5					27.8	25.2							18
20	27.3	19.8	15.5	11.8	9.8	7.9	30.0	27.1	19.5	15.2	11.6			27.2	24.6	19.2	14.6					20
22	25.9	18.8	14.6	11.2	9.3	7.5	28.8	25.9	18.6	14.4	11.0	9.1		26.3	24.1	18.4	14.0	10.6				22
24	24.8	17.9	14.0	10.6	8.8	7.1	27.6	24.8	17.8	13.8	10.5	8.7	6.9	25.3	23.3	17.7	13.4	10.3	8.5			24
26	23.7	17.1	13.3	10.2	8.5	6.7	25.7	23.8	17.0	13.2	10.1	8.3	6.6	24.3	22.4	17.0	12.8	9.8	8.1			26
28	22.1	16.2	12.7	9.7	8.0	6.5	24.0	22.4	16.2	12.6	9.6	8.0	6.3	22.9	21.5	16.3	12.4	9.4	7.7			28
30	19.6	15.6	12.2	9.3	7.7	6.1	21.1	19.8	15.6	12.2	9.2	7.6	6.0	20.3	20.1	15.7	11.9	9.0	7.4			30
32	17.4	14.9	11.6	8.9	7.3	5.8	18.6	17.6	15.0	11.6	8.8	7.3	5.8	18.0	17.9	15.1	11.4	8.6	7.1			32
34	15.5	14.3	11.1	8.6	7.0	5.6	16.5	15.7	14.4	11.2	8.6	7.0	5.5	15.9	16.0	13.6	11.0	8.4	6.8			34
36	13.8	13.8	10.6	8.2	6.7	5.3	14.6	14.0	13.0	10.7	8.2	6.7	5.3	14.2	14.3	12.2	10.6	8.1	6.6			36
38	12.3	12.5	10.3	7.8	6.5	5.1	12.9	12.5	11.7	10.4	7.9	6.5	5.0	12.6	12.9	11.0	10.3	7.8	6.4			38
40	11.0	11.3	9.8	7.5	6.2	4.8	11.4	11.2	10.6	10.0	7.5	6.2	4.8	11.2	11.6	10.0	9.7	7.5	6.2			40
42	9.8	10.2	9.4	7.1	5.9	4.7	10.1	10.0	9.6	9.5	7.2	6.0	4.7	9.9	10.4	9.0	8.9	7.2	5.9			42
44	8.7	9.2	8.6	6.8	5.7	4.5	8.9	9.0	8.6	8.7	6.9	5.8	4.5	8.8	9.3	8.2	8.1	6.9	5.7			44
46	7.8	8.2	7.8	6.6	5.4	4.3	7.8	8.0	7.8	7.9	6.7	5.5	4.3	7.8	8.3	7.4	7.4	6.7	5.5			46
48	6.9	7.4	7.1	6.3	5.2	4.1	6.8	7.1	7.0	7.2	6.5	5.3	4.1	6.8	7.5	6.7	6.7	6.5	5.3			48
50	6.1	6.7	6.4	5.9	5.0	3.9	5.9	6.3	6.3	6.5	5.9	5.1	4.0	6.0	6.7	6.0	6.1	6.0	5.1			50
52	5.3	6.0	5.8	5.4	4.8	3.8	5.0	5.6	5.7	5.9	5.8	4.9	3.8	5.2	5.9	5.4	5.6	5.5	4.9			52
54	4.6	5.3	5.3	4.9	4.6	3.6	4.2	4.9	5.1	5.4	5.6	4.8	3.6	4.5	5.2	4.9	5.1	5.1	4.8			54
56	4.0	4.7	4.8	4.5	4.4	3.4	3.5	4.3	4.5	4.9	5.1	4.5	3.5	3.8	4.6	4.4	4.6	4.6	4.5			56
58	3.4	4.2	4.3	4.1	4.1	3.2	2.8	3.7	4.0	4.4	4.8	4.1	3.3	3.2	4.0	3.9	4.2	4.2	4.2			58
60	2.8	3.6	3.9	3.7	3.8	3.1	2.1	3.1	3.5	4.0	4.6	3.8	3.2	2.5	3.5	3.5	3.8	3.9	3.8			60
62	2.1	3.1	3.4	3.4	3.5	2.9		2.2	3.1	3.5	4.3	3.5	3.0	1.8	2.4	3.1	3.4	3.5	3.5			62
64		2.4	3.1	3.1	3.2	2.9			2.3	2.9	3.9	3.2	2.9			2.7	3.0	3.1	3.2			64
66		1.7	2.5	2.8	2.9	2.8				2.6	3.5	2.9	2.9			2.1	2.5	2.6	2.8			66
68			1.8	2.2	2.6	2.7				1.8	3.1	2.6	2.5				1.9	1.9	2.5			68
70				1.6	1.9	2.4					2.6	1.9	2.2						1.9			70
72						2.0					2.3		1.8									72
74						1.3					1.6		1.1									74
n	3	2	2	1	1	1	3	3	2	2	1	1	1	3	3	2	2	1	1			n
m/s	9.0	9.0	9.0	9.0	9.0	9.0	9.0	9.0	9.0	9.0	9.0	9.0	9.0	9.0	9.0	9.0	9.0	9.0	9.0			m/s

Tower Jib With Superlift Operating Range

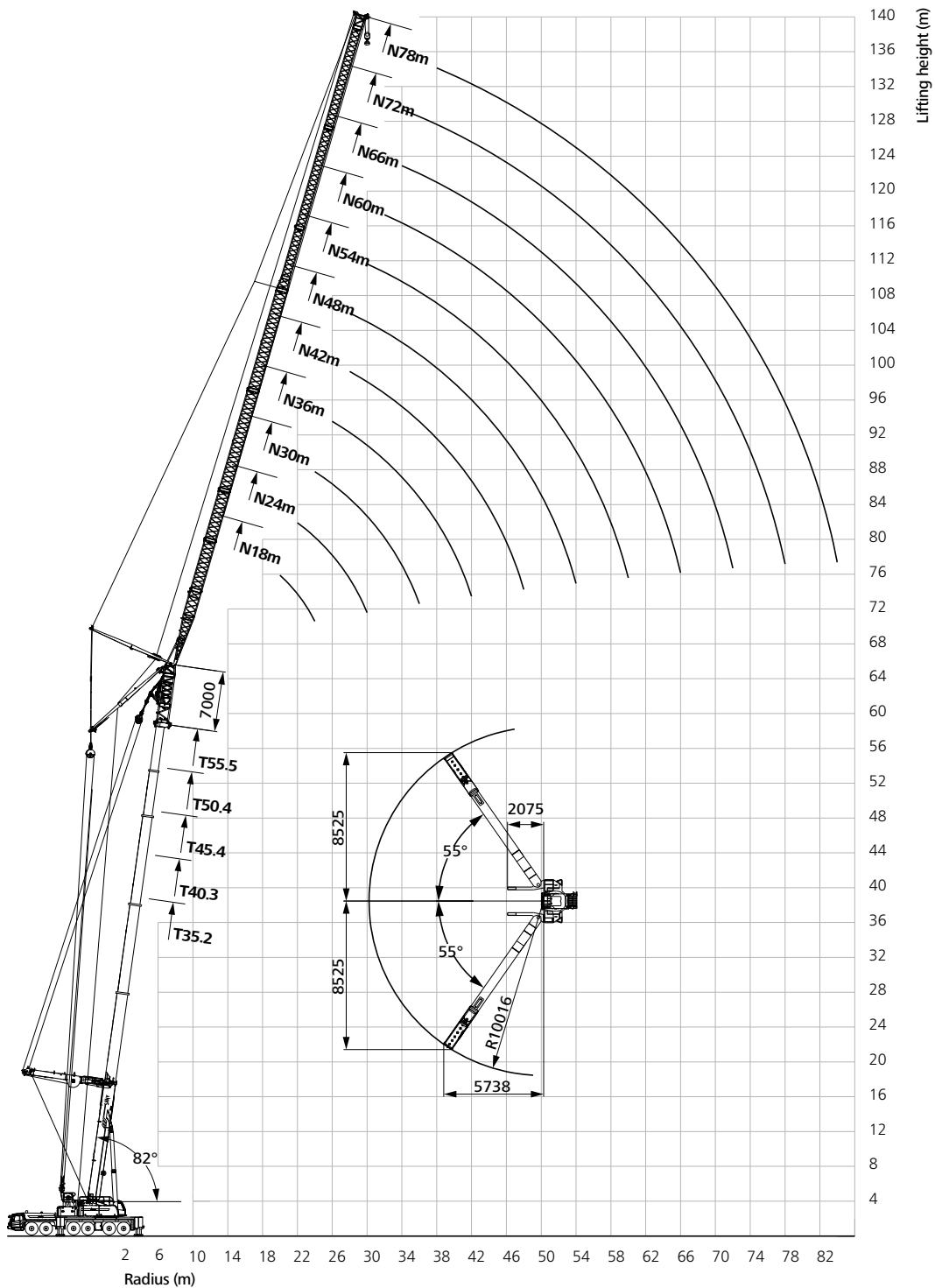

Load Chart - Tower Jib With Superlift

Unit: t

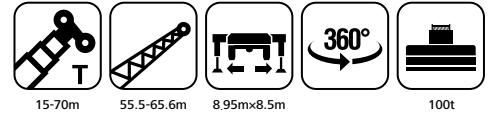

Working radius(m)	55.5m											60.6m						65.6m				Working radius(m)	
	18m	24m	30m	36m	42m	48m	54m	60m	66m	72m	78m	18m	24m	30m	36m	42m	48m	18m	24m	30m	36m		
20	26.5											24.5											20
22	26.0	23.0										23.5	20.0					21.0					22
24	25.5	22.1	19.5									23.0	19.5	17.0				20.0	17.5				24
26		22.0	18.8	16.0								22.5	19.2	16.5	14.0			19.5	16.5	14.9			26
28		21.3	18.5	15.8	11.5	10.0						19.0	16.0	13.5	11.4			16.0	14.0	12.5			28
30		21.0	18.0	15.8	13.0	10.3	7.8					18.0	15.6	13.5	11.3	9.3		15.0	13.7	12.0			30
32			17.5	15.3	13.0	10.6	8.3	6.0				17.2	15.2	13.5	11.2	9.5		15.0	13.4	12.0			32
34			17.0	15.3	13.0	11.0	8.5	6.2	3.5	2.5			15.0	13.2	11.1	9.5			13.1	11.3			34
36			16.9	15.0	13.0	10.8	8.7	6.5	4.0	2.8			14.8	13.0	11.0	9.5			12.5	11.1			36
38				14.6	12.5	10.6	8.7	6.5	4.5	3.0	1.5		14.0	12.7	10.9	9.5			12.0	10.9			38
40				14.2	12.3	10.4	8.7	6.5	5.0	3.5	1.6			12.5	10.7	9.3				10.7			40
42				14.0	12.1	10.2	8.5	6.5	5.0	3.7	1.8			12.3	10.4	9.2				10.4			42
44					11.9	10.0	8.5	6.5	5.0	3.7	2.0			12.0	10.2	9.1				9.5			44
46					11.5	9.8	8.4	6.5	5.0	3.7	2.3				10.1	8.9							46
48					11.0	9.6	8.2	6.5	5.0	3.7	2.5				10.0	8.7							48
50						9.4	8.1	6.5	5.0	3.7	2.5				9.0	8.5							50
52						9.2	8.0	6.5	5.0	3.7	2.5					8.3							52
54						9.0	7.8	6.3	5.0	3.7	2.6					8.1							54
56							7.6	6.2	5.0	3.7	2.6					7.8							56
58							7.3	6.1	4.9	3.7	2.6												58
60							7.0	6.0	4.8	3.7	2.6												60
62								5.8	4.7	3.7	2.6												62
64								5.6	4.6	3.7	2.6												64
66								5.5	4.5	3.7	2.6												66
68									4.4	3.6	2.6												68
70									4.2	3.5	2.4												70
72									4.0	3.4	2.2												72
74										3.2	2.1												74
76										3.0	2.0												76
78										2.7	1.9												78
80											1.8												80
82											1.7												82
84											1.5												84
n	3	2	2	2	1	1	1	1	1	1	1	2	2	2	2	1	1	2	2	2	1	n	
m/s	9.0	9.0	9.0	9.0	9.0	9.0	9.0	9.0	9.0	9.0	9.0	9.0	9.0	9.0	9.0	9.0	9.0	9.0	9.0	9.0	9.0	m/s	



Sany Automobile Hoisting Machinery Co., Ltd.

No.168, Jinzhou Avenue, Jinzhou Development Zone, Changsha, Hunan, China

Postcode 410600

Tel +86 731-8787 3131 Fax +86 731-8403 1999-196

Service 400 887 8318 Consulting 400 887 9318

Email qzjyx@sany.com.cn

— Authorised Dealer —

Reminder:

For safe and reliable operation of the diesel engines, please fill Grade IV machines with Grade IV diesel and urea solution conforming to related national standards. Please refer to the operating instructions and related standards for details.

Any change in the technical parameters and configuration due to advancement in technology may occur without prior notice. The machine in the figures may include auxiliary equipment. This brochure is for reference only, and goods in kind shall prevail.

Copyright at Sany Heavy Industry. No part of this catalogue may be copied, recorded or used for any purpose without written approval from Sany Heavy Industry.

© Printed in August 2019 in China

www.sanyglobal.com

