

Technical Specifications

# Princeton PB55



**PRINCETON**  
DELIVERY SYSTEMS®



# Princeton PB55 Technical Specifications

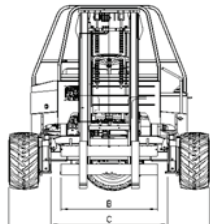
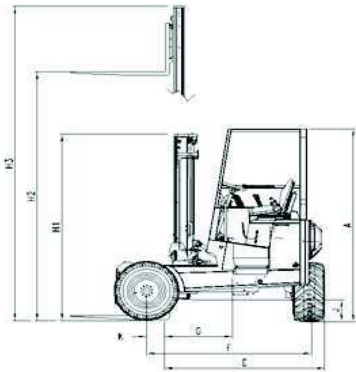

	Model	PB55
	TYPE	Standard
1	CAPACITY @ 24" LOAD CENTER	5500 lbs
2	DIESEL ENGINE	56 HP
3	ENGINE EMISSION COMPLIANCE	EPA Tier4 Final
4	MAXIMUM RPM	2600 RPM
5	ELECTRICAL SYSTEM	12 Volt
6	DRIVE WHEELS	3
7	STEERING	Hydrostatic
8	TIRE TYPE	31 x 15.5 - 15 8-Ply (TG)
		31 x 15.5 - 15 8-Ply (TG)
9	TIRE OUTSIDE DIAMETER	31"
10	TIRE WIDTH	15.5"
11	MAXIMUM SPEED	7 mph
12	MAXIMUM GRADABILITY	30%
13	TURNING RADIUS	86"
14	UNLADEN WEIGHT	6670 lbs
14a	UNLADEN WEIGHT (OPTIONAL)	6820 lbs
15	WORKING PRESSURE (ATTACHMENTS)	2500 psi
16	TILT OF MAST (FORWARD/BACKWARD)	10° / 8°
17	SIDESHIFT	5"
18	FORK SECTION	45 x 4 x 1.75"
19	MAST CARRIAGE TRAVEL	25"
A	HEIGHT TO TOP OF CANOPY	101"
B	FORK CARRIAGE WIDTH (CLASS)	48.25" (II)
C	FRAME OPENING	57.75"
D	OVERALL WIDTH	101"
E	OVERHANG	80"
F	WHEELBASE	77.5"
G	CENTER OF GRAVITY (FROM FORK FACE)	26.5"
H1	LIFT HEIGHT	120"
H2	MAST HEIGHT - COLLAPSED	97.25"
H3	MAST HEIGHT - RAISED	157"
H1a	LIFT HEIGHT	144"
H2a	MAST HEIGHT - COLLAPSED	109.25"
H3a	MAST HEIGHT - RAISED	181"
J	GROUND CLEARANCE	11"
K	FACE OF FORK TO CENTER OF FRONT TIRE	9"
L	ANSI STANDARD	B56.6

The above specifications are not binding upon the manufacturer and may be changed without prior notice.

High Torque Transmission (HTT) option available - increases torque by 30%\*

Weights may vary, depending on tire and/or fork options

\*HTT equipped models will have a reduced maximum ground speed

**PRINCETON**  
DELIVERY SYSTEMS®

**Princeton Delivery Systems**

12233 Williams Road  
Perrysburg, OH 43551 USA  
tel 1.800.331.5851  
[www.piggy-back.com](http://www.piggy-back.com)

A Part of the Hiab Group  
V2016.08.22

Courtesy of CraneMarket.com

For more information, contact your local PiggyBack Dealer