

480 ATT

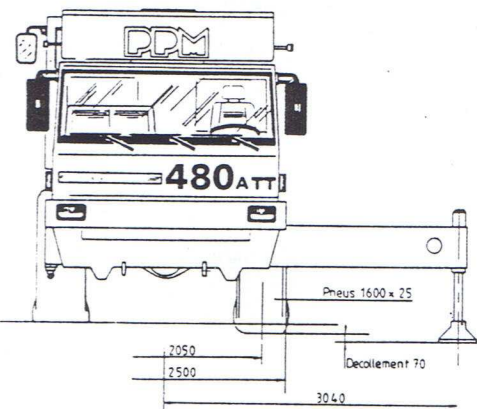

VEHICLE WEIGHT (with full oil and fuel tanks, with driver)		
BASIC MACHINE WITH	<ul style="list-style-type: none"> ● Full 5.6 t counterweight. ● 3-seater cab. ● 16.00 R 25 XVC tyres. ● 20 T hookblock. 	32.8 T
MACHINE WITH	<ul style="list-style-type: none"> ● Full 5.6 t counterweight. ● 40 t hookblock (or 45 t) and 10 t hookblock. ● 3-seater cab. ● 16.00 R 25 XVC tyres. ● Lattice extension and stinger. 	33.8 T
COMPLETE MACHINE WITH	<ul style="list-style-type: none"> ● Full 5.6 t counterweight. ● 40 t hookblock (or 45 t) and 10 t hookblock. ● 3-seater cab. ● 16.00 R 25 XL tyres. ● Lattice extension and stinger. ● Spare wheel 16.00 R 25 XL. ● 2nd winch. 	34.5 T

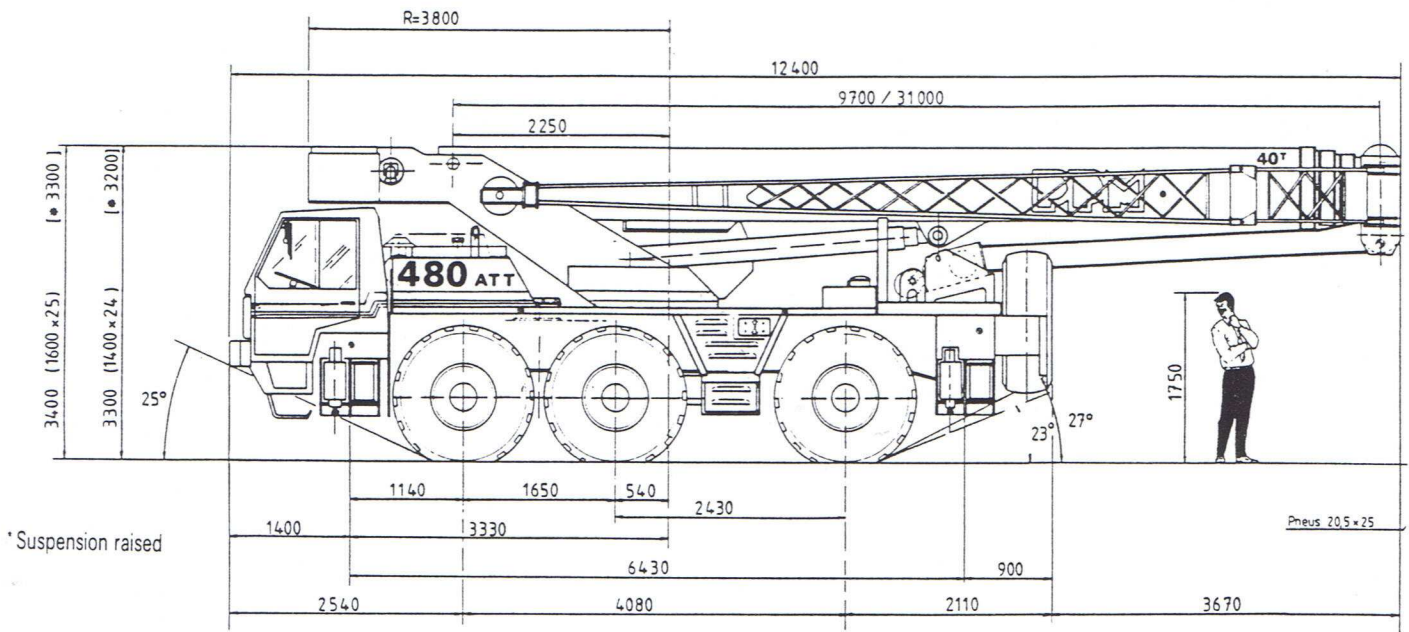
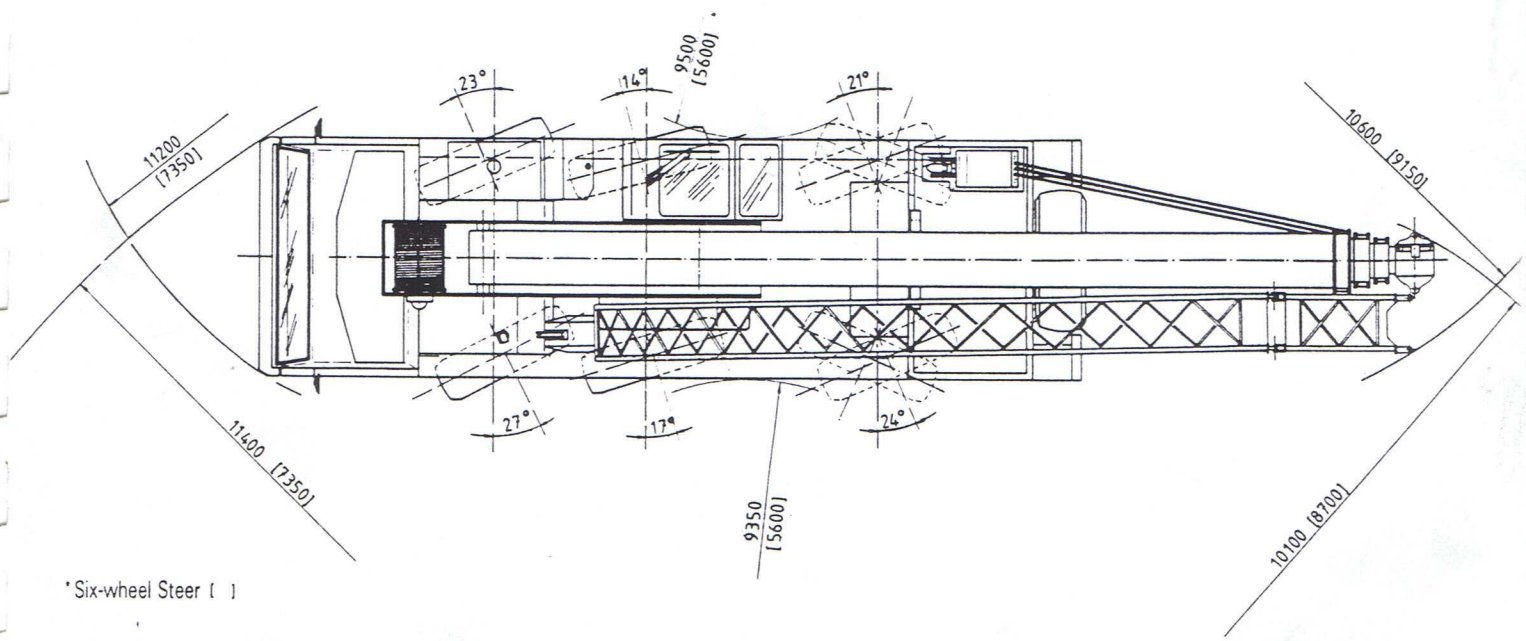

* Six-wheel Steer []

45-tonne capacity, 3 axles : power and mobility.

MAXIMA CAPACITY

Metric tonnes

at 2,5 m over 360°	at 2,8 m over 360°
45 t	45 t
75 %	85 %

MAIN CHARACTERISTICS

- 3-Axle all-terrain crane.
- 4-element telescopic boom with automatic continuous synchronisation of elements from 9.7 m to 31.0 m.
- Maximum on-board tip height : 48 m.
- Capacity at maximum height (32 m under hook) : 10 tonnes.
- Maximum width : 2.50 m with standard 16.00 R 25 tyres.
- 6-wheel steer and crab steer.
- PPM Hydrostable suspension : hydropneumatic suspension, with adjustable ground clearance, automatic levelling and slope compensation.
- DEUTZ BF6L 513RC Turbodiesel, 286 hp (210 kW) DIN

UPPERSTRUCTURE

Telescopic boom

4-section boom with 9.7 m basic boom and 3 hydraulically powered, continuously synchronised sections.

Boom sections : PPM design and manufacture, consisting in 4 high-tensile steel plates assembled by continuous automatic electrowelding.

- Rectangular section and use of plates with different thickness gives high rigidity/weight ratio.
- Telescopic sections slide on integral wear pads. Side pads can be adjusted externally.

Telescoping : 1 double acting ram with single rod (stroke 7.1 m).

Extend synchronisation by multiple cables, retract synchronisation by chain. No hoses inside boom.

Length :

- Retracted : 9.7 m / - Extended : 31.0 m

Telescoping speed : - 65 s for total extension (23 m/min).
- 90 s for total retraction (32 m/min).

Boom derricking :

- Single double acting ram. Negative boom angle makes reeving and working on boomhead easier. Maximum angle : 80°. Minimum angle : - 2°.
- Total derricking time : 50 seconds.

Winches :

Main winch : designed by PPM.

- Drum : 310 mm diameter grooved for 15 mm rope, with rope press device.
- High-speed hydraulic motor with reduction gear. Max linespeed : 120 m/mn. Max single linepull : 4.45 t (first layer).
- Safety braking system : spring applied, hydraulically released multi-disc type. Non-return sprag clutch.
- Antirotating wire rope with metallic core, 15 mm diameter. Resistance 206 KN (21 000 kg). Total length : 150 m.

Auxiliary winch : designed by PPM.

- Max. linepull : 3.1 t (1st layer).
- Max. linespeed : 150 m/min.
- 12 mm diameter wire rope. Winch capacity : 120 m.
- Resistance : 147 KN (15.000 kg).

Slewing :

- Ball bearing slewing ring with external gear teeth, bolted on chassis 40 bolts and on upperstructure by 44 bolts.
- Hydraulic motor drives a 3-stage reducer, reduction ratio 14:1 enables slow and precise movements. Static hydraulic disc brake integrated in reducer, hydraulically released.
- Slewing speed : from 0 to 1.5 r.p.m.
- Electromagnetic transport lock, pneumatically operated from upper cab, electric indicator of positive locking.

Upperstructure hydraulic circuit :

- 11-way rotary manifold.
- Proportional valve block, positioned on right hand side of upperstructure and protected by cover.
- Hydraulically-powered controls ; on the left of operator's seat : joysticks gives cross control of slewing and derricking ; on the right of operator's seat : single lever-type hoist control ; pedal operates telescope.

Uppercab :

- Full-vision deluxe cab.
- Comprehensive dashboard. Printed circuit wiring of all warning control lights simplifies wiring.
- Deluxe seat with head and armrests, adjustable for length, height backrest angle.
- 2-speed electric windscreen wiper. Electric wiper on roof window. Window slides and rear window swings up to provide good ventilation. Sliding door.
- White spotlight to read loadcharts, etc.
- Independent 2 kW oil heater and fan.

CARRIER SPECIFICATIONS

- Self-propelled 3-axle 6 × 4 × 6 carrier specifically designed by PPM.
- 3-seater road cab. PPM Hydrostable suspension.
- Unobstructed rear platform enables true pick-and-carry.
- Built-in stowage box.
- Maximum road speed : 72 km/h (45 m.p.h.).

Frame :

Electrically welded unitised box section, constructed from high tensile steel.

Outriggers :

- All-welded box section outrigger beams extend horizontally to a max width of 6.08 m.
- Distance between centreline of front and rear double-box housings : 6.4 m.
- Hydraulically operated vertical outrigger jacks with holding valves. Stroke : 505 mm. Max-wheel clearance on outriggers : 70 mm.
- Quick release outrigger pads, Ø 550 mm, stowage on carrier at convenient height.
- Stabiliser beams can be locked for road travel.
- Outrigger control positions, one in upperstructure cab, one on carrier, with independent operation of horizontal and vertical extension.
- Beam extension time : 18 sec. Outrigger jacks extension time : 20 sec.

Engine :

- DEUTZ BF6L 513 RC air cooled Turbodiesel
- 286 hp (210 kW CEE) at 2300 r.p.m. on road
- 272 hp (200 kW 6270 B) at 2000 r.p.m. on site
- Intercooler reduces pollution and fuel consumption.
- Equipment : 300 cm³ compressor, 55 A alternator, 4.8 kW electric starter.
- Pneumatically operated exhaust brake.
- STEMCO silencer.

Transmission :

- ZF Torque converter and Powershift gearbox, 6 forward and 3 reverse speeds :
- Automatic lock-up on speeds from 3 to 6 reduces fuel consumption.
- Disengageable PTO for main hydraulic pump.
- PTO to front axle can be disengaged for 6 × 2 drive.
- PTO for emergency steering pump.

Torque converter and main hydraulic circuit are both cooled by 2 radiators mounted away from the engine compartment. Hydraulically driven. Capacity 30 000 kcal - 40 kW.

1st front axle : KESSLER drive/steer axle

- With planetary hub reductions.
- Simplex drum brakes.
- Differential lock from both cabs.

2nd front axle : KESSLER steer axle

- Simplex drum brakes.

Rear axle : KESSLER drive/steer axle

- With planetary hub reductions.
- Simplex drum brakes.
- Differential lock from both cabs.

PPM Hydrostable suspension

- Dropneumatic suspension acts independently on each axle, through 6 rams connected to gas accumulators.
- Side slope compensation.
- Ground clearance adjustment.
- Automatic levelling.
- Hydraulic lock-out for pick-and-carry operation.

Steering

Lower cab

- Steering wheel controls power-assisted steering box which simultaneously steers both front axles. 1 steering ram on each axle.
- Joystick gives hydrostatic steering of the rear axle on 1st forward or reverse speed.
- Rear steering locks for road travel.

Upperstructure cab :

- Hydrostatic steering of rear axle through steering wheel.
- Joystick gives hydrostatic steering of both front axles on all-speeds.

Pumps :

- Main pump : engine-driven 32 cm³ ZF pump.
- Emergency pump : gearbox-driven 32 cm³ pump.

Braking :

- Main brake (pedal-operated) : pneumatically-operated drum brakes on all 6 wheels.
- Back-up brake : spring-applied brakes on both rear axles.
- Pneumatically-operated spring-applied park brakes on rear axle.
- Exhaust brake.

Tyres :

- Standard tyres : 16.00 R 25 XVC
- Optional : 14.00 R 24 XVC or 16.00 R 25 XLB

CIRCUITS

Hydraulic circuit :

- Main hydraulic circuit (winches 1 and 2, telescoping, derricking, slewing, outriggers, steering from turret cab) is powered by a variable displacement pump with automatic "Load Sensing" adjustment of flow to operating requirements. All crane motions can be either independent or simultaneous. Proportional hydraulic controls.
- A 16 cm³ gear pump, built into the main pump drives the suspension circuit and the oil-cooler fan.
- Hydraulic oil tank is T-shaped to leave rear platform unobstructed. Capacity : 450 l. 10 µ filtration on return flow.
- Hydraulic circuit is cooled by a radiator placed away from the engine compartment, coupled to the torque converter cooler. Capacity 30 000 kcal - 40 kW.

Electrical system :

- 24 V circuit - 2 × 12 V, 160 Ah batteries.
- 35-way slipping.
- Circuit breaker protection.
- High-quality Deutsche connectors.
- Printed circuits in lower and upperstructure cabs reduce wiring.
- Safety device on selection of driving position.

Air circuit :

- 300 cm³ compressor.
- Electric air scrubber regulates, deshydrates and purifies.
- Tyre inflater.
- Separate air tanks for braking (2 × 60 l) and for other services (30 l).

SAFETY DEVICES

- Check valves on telescoping, derricking, hoisting, outriggers.
- Hydraulic speed limiters on all load lowering motions.
- Pressure limiters on all hydraulic functions.
- Anti 2-block device, lower stroke block limiter.
- Switch under upper cab seat prevents operation of upperstructure if operator is not on seat.

OPTIONS

9 m lattice extension, with or without 5 m stinger. Offset angle : 0° or 30°.

Single-sheave hookblock or single fall hook.

Rooster sheave for single line work on main boom.

Spare wheel : 16.00 R 25 - 14.00 R 24 (according to the chosen tyres). Mounted on rear of chassis. Wheel can be handled using a cable and the boom telescope.

14.00 R 24 XVC - 16.00 R 25 XLB tyres.

PPM auxiliary winch mounted on rear of upperstructure (increase overall height on std. tyres from 3.40 m to 3.55 m).

Single seat lower cab.

Load moment indicator.

NOTE : PPM reserves the right to modify the above specifications which are given as a guide only (figures in accordance with metric system).



A STANDARD YOU CAN TRUST

Head office and factory:
Z.I. de La Saule - F - 71303 MONTCEAU-LES-MINES
Export sales:
Le Descartes - F - 93191 NOISY-LE-GRAND Cedex
Tél.: (1) 43 05 10 50
Fax: (1) 43 05 72 55
Télex: 232 441 PPM

480 ATT

LIMITE DE FLECHE A VIDE SUR 360°
 BOOM LIMITS WITH NO LOAD AND OVER 360°
 AUSLEGERGRENZEN OHNE LAST UBER 360°
 LIMITES DE PLUMA EN VACIO Y DE LADO 360°

En levage sur l'extension treillis ou le prolongateur le moufle de fleche doit être soit démonté, soit reposé au sol.

When hoisting with lattice extension or stinger the boom hook block must either be removed or rest on the ground.

Beim Heben mit der Gitterverlängerung oder der Klinker verlängerung muss der Auslegerflaschenzug entweder ausgebaut werden oder auf dem Boden liegen.

En elevacion con extension celosia o el prolongador el polepato de pluma debe ser desmontado o bie reposar sobre el suelo.

SUR STABILISATEURS EN EXTENSION TOTALE
 ON OUTRIGGERS TULLY EXTENDED
 AUF ABSTUZZUNGEN VOLLAUSGEFAHREN
 SOBRE ESTABILIZADORESEXTENCION TOTAL

5 DEDUCTIONS DE CHARGES
 LOAD DEDUCTIONS
 LASTBUZUEGE
 DEDUCCIONES DE CARGA

3.5 T	3.5 à 10 T	40 T
-45 kg	-160 kg	-350 kg
-99 LBS	-353 LBS	-772 LBS

SUR STABILISATEUR		PNEUMATIQUE	
	∞ mini pour L maxi	L maxi pour ∞ 0°	L maxi pour ∞ 0°
1	0°	31 m	16.80M
2	25°	27 m	INTERDIT
3	25°	26 m	
4	18°	27 m	
5	30°	26 m	

- 1360 kg	- 1550 kg
- 2998 LBS	- 3417 LBS

- 1250 kg	- 1360 kg
- 2756 LBS	- 2998 LBS

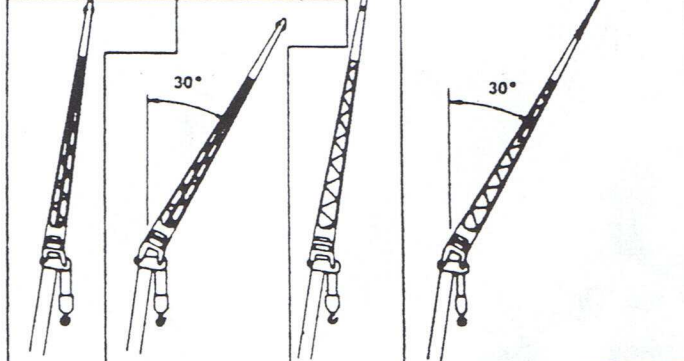

8.95 m	- 760 kg
	- 1674 LBS

- 850 kg
- 1874 LBS

L = 31 m + 1.45 m + 7.50 m + 5 m
 101'9" + 4'9" + 24'7" + 16'5"

L = 31 m + 1.45 m + 7.50 m
 101'9" + 4'9" + 24'7"

L = 31 m
 101'9"

SPECIMEN donné à titre indicatif seulement.
 Se référer à l'exemplaire dans la cabine.
 For information only.
 Refer to sheet in cab.
 EJEMPLO para información solamente.
 Referirse al ejemplar en la cabina.

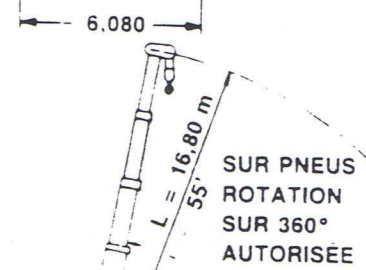

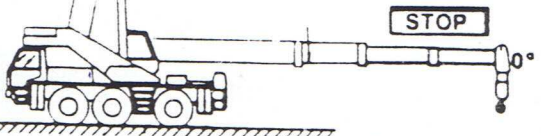

SUR PNEUS
 ROTATION
 SUR 360°
 AUTORISÉE

SUR PNEUS
 ROTATION
 SUR 360°



Main boom

* SCHWENKBEREICH 360°, ABSTÜTZUNGEN VOLL AUSGEFAHREN
 * ON OUTRIGGERS FULLY EXTENDED OVER 360°

 m ***	VOLL HYDRAULISCHER TELESKOPISCHER AUSLEGER VON 9.70 m bis 31 m FULLY TELESCOPIC BOOM FROM 9.70 m to 31 m							 m ***
	9.70 m	13.25 m	16.80 m	20.35 m	23.90 m	27.45 m	31.00 m	
2.5	45.00	19.00	19.00	17.50				2.5
3.0	40.00	13.00	19.00	17.50				3.0
3.5	32.20	19.00	19.00	17.50	15.00			3.5
4.0	30.20	19.00	19.00	17.50	15.00			4.0
4.5	27.00	19.00	19.00	17.50	15.00	13.00		4.5
5.0	22.20	19.00	19.00	17.50	15.00	13.00	10.00	5.0
6.0	20.00	19.00	19.00	17.50	15.00	13.00	10.00	6.0
7.0	16.90	16.80	16.90	16.65	15.00	13.00	10.00	7.0
8.0		14.50	14.70	14.45	14.45	13.00	10.00	8.0
9.0		11.55	11.80	11.50	11.50	11.90	10.00	9.0
10.0		9.80	10.05	9.95	9.95	10.55	9.45	10.0
11.0			8.55	8.60	8.65	8.70	8.55	11.0
12.0			7.30	7.35	7.40	7.45	7.70	12.0
13.0			6.35	6.40	6.45	6.55	6.70	13.0
14.0			5.55	5.55	5.70	5.80	5.95	14.0
15.0				4.85	5.00	5.05	5.15	15.0
16.0				4.30	4.35	4.45	4.55	16.0
17.0				3.80	3.80	3.85	4.00	17.0
18.0				3.35	3.40	3.45	3.60	18.0
19.0					3.00	3.05	3.20	19.0
20.0					2.75	2.75	2.95	20.0
21.0					2.40	2.45	2.60	21.0
22.0						2.20	2.40	22.0
23.0						2.00	2.15	23.0
24.0						1.85	1.95	24.0
25.0						1.60	1.75	25.0
26.0							1.55	26.0
27.0							1.35	27.0
28.0							1.20	28.0

GEGENGEWICHT: 5.600 kg - BASIC MACHINE = CWT 5.600 kg

Δ REIFEN (Federung blockiert)

Δ FREE ON WHEELS (Front and rear suspensions locked)

 m ***	IN DER LANGSACHE NACH HINTEN 20 OVER REAR			 m ***
	9.70 m	13.25 m	16.80 m	
3.0	13.30			3.0
3.5	11.85			3.5
4.0	10.55			4.0
4.5	9.50	9.65	9.80	4.5
5.0	8.55	8.75	8.85	5.0
6.0	7.10	7.25	7.40	6.0
7.0	5.95	6.15	6.25	7.0
8.0		5.25	5.35	8.0
9.0		4.55	4.65	9.0
10.0		3.95	4.05	10.0
11.0			3.55	11.0
12.0			3.10	12.0
13.0			2.75	13.0
14.0			2.40	14.0

Bei Arbeiten in nicht abgestütztem Zustand ist zu beachten: Blockierung der Aufhängungen, vorgeschriebener Reifendruck, fester, ebener Untergrund. Lasten verfahren über die Vorderachse. Ausleger kurz, Last in geringer Höhe über dem Boden, nach Möglichkeit am Unterwagen verortet. Kleinstmögliche Geschwindigkeit im niedrigsten Gang.

Free-on-wheels: operate on a firm and level surface with tyres inflated to the recommended pressure and front and rear suspension locked. For lift and carry operation use the shortest boom centered over rear of the chassis with the load slung close to the chassis.

*** SCHWENKBEREICH 360°, ABSTÜTZUNGEN VOLL AUSGEFAHREN**
▲ ON OUTRIGGERS FULLY EXTENDED OVER 360°

 ***	GITTERVERLÄNGERUNG MIT KASTENPROFIL-SOITZE LATTICE EXTENSION WITH STINGER			
	VERLÄNGERUNG 9 m STINGER RETRACTED		VERLÄNGERUNG 14 m STINGER EXTENDED	
	31 m + 9 m		31 m + 14 m	
	0°	30°	0°	30°
7.0	4.50			
8.0	4.50			
9.0	4.50		2.95	
10.0	4.50		2.80	
11.0	4.50	3.05	2.65	
12.0	4.20	3.00	2.50	
13.0	3.90	2.90	2.40	
14.0	3.60	2.75	2.30	
15.0	3.35	2.60	2.20	1.35
16.0	3.15	2.50	2.10	1.35
17.0	2.95	2.35	2.00	1.30
18.0	2.75	2.25	1.95	1.30
19.0	2.60	2.15	1.90	1.25
20.0	2.45	2.05	1.80	1.25
21.0	2.30	1.95	1.75	1.20
22.0	2.15	1.85	1.70	1.20
23.0	2.00	1.80	1.65	1.20
24.0	1.75	1.70	1.60	1.15
25.0	1.55	1.65	1.55	1.15
26.0	1.35	1.60	1.50	1.15
27.0	1.20	1.55	1.45	1.10
28.0	1.00	1.40	1.40	1.10
29.0	0.80	1.20	1.25	1.10
30.0	0.70	0.85	1.10	1.10
31.0	0.55	0.75	0.95	1.05
32.0	0.40	0.60	0.85	1.05
33.0		0.45	0.70	0.95
34.0			0.60	0.80
35.0			0.50	0.65
36.0			0.40	0.55
37.0				0.45

GEGENGEWICHT: 5.600 kg - BASIC MACHINE + CWT 5600 kg

HINWEISE

1 - Die angegebenen Tragkräfte sind die maximalen Tragkräfte, die durch die Garantie des Herstellers abgedeckt werden. Sie sind in metrischen Tonnen angegeben. Das Gewicht der Haken, Hakenflaschen und des Hubzubehörs ist von diesen angegebenen Tragkräften abzuziehen.

Tragkraftabzüge:

- Bei Arbeiten mit dem Hauptausleger bei angebauten Verlängerungen: abzügen 1550 kg
- Hakenflasche und Haken (siehe Tabelle).

2 - Die oberhalb der starkgedruckten Linien angeführten Tragkräfte hängen von der Baufestigkeit gewisser Maschinenteile ab. Die Tragkräfte unter dieser Linie sind durch die Standfestigkeit des Krans bedingt. Die Lastwerte unterhalb der Linien entsprechen DIN 15019, Teil 2, ISO 4305, ONORM B 4004 Teil 2, SFS 4406.

3 - PPM behält sich das Recht vor, falls erforderlich die Maschinen in Bezug auf die hier zu Ihrer Orientierung gegebenen Angaben zu ändern.

NOTES

1 - The tabulated loads are the maximum values covered by the manufacturer's guarantee. They are given in metric tonnes and include the weight of hook block and other hoisting equipment.

Deductions from rated loads:

- Use of main boom with extension erected: deduct 1550 kg.
- Hook blocks (see specification chart).

2 - Loads above the bold horizontal line are based on structural strength. Loads below the bold line are based on machine stability. The rated loads are in accordance with DIN 15019/Teil 2, ISO 4305, ONORM B 4004/Teil 2, SFS 4406.

3 - PPM reserves the right to modify the above specifications which are given as a guide only (figures in accordance with metric system).

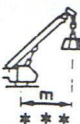
 ***	GITTERVERLÄNGERUNG OHNE KASTENPROFIL-SOITZE LATTICE EXTENSION WITHOUT STINGER	
	31 m + 9 m	
	0°	30°
	7.0	4.80
8.0	4.80	
9.0	4.80	
10.0	4.80	
11.0	4.80	3.35
12.0	4.50	3.30
13.0	4.20	3.20
14.0	3.90	3.05
15.0	3.65	2.90
16.0	3.45	2.80
17.0	3.25	2.65
18.0	3.05	2.55
19.0	2.90	2.45
20.0	2.75	2.35
21.0	2.60	2.25
22.0	2.45	2.15
23.0	2.30	2.10
24.0	2.20	2.00
25.0	1.90	1.95
26.0	1.70	1.90
27.0	1.50	1.85
28.0	1.35	1.75
29.0	1.15	1.50
30.0	1.05	1.30
31.0	0.90	1.10
32.0	0.70	0.95
33.0	0.60	0.80
34.0	0.50	0.65
35.0	0.40	0.55
36.0		0.50
37.0		0.40

GEGENGEWICHT: 5.600 kg - BASIC MACHINE - CWT 5600 kg

**DIE LASTAUFNAHMEMITTEL
HOOK BLOCKS AND HOOKS**

Traglast Lifting capacities	Rollen Pulleys	Stränge Parts of line	Gewicht Weight
45 t	6	13	420 kg
40 t	6	12	350 kg
20 t	3	6	245 kg
10 t	1	3	125 kg
3.5 t	-	1	50 kg

PPM
7 SO' IDES KÖNNEN

Firmensitz und Werk:
 Z.I. de La Saule - F - 71304 MONTCEAU-LES-MINES
 Verkauf:
 Le Descartes - F - 93191 NOISY-LE-GRAND Cedex
 Tél.: (1) 43 05 10 50
 Fax: (1) 43 05 72 55
 Téléc: 232 441 PPM

Lifting capacities / Lifting heights

Forces et hauteurs de levage

BS

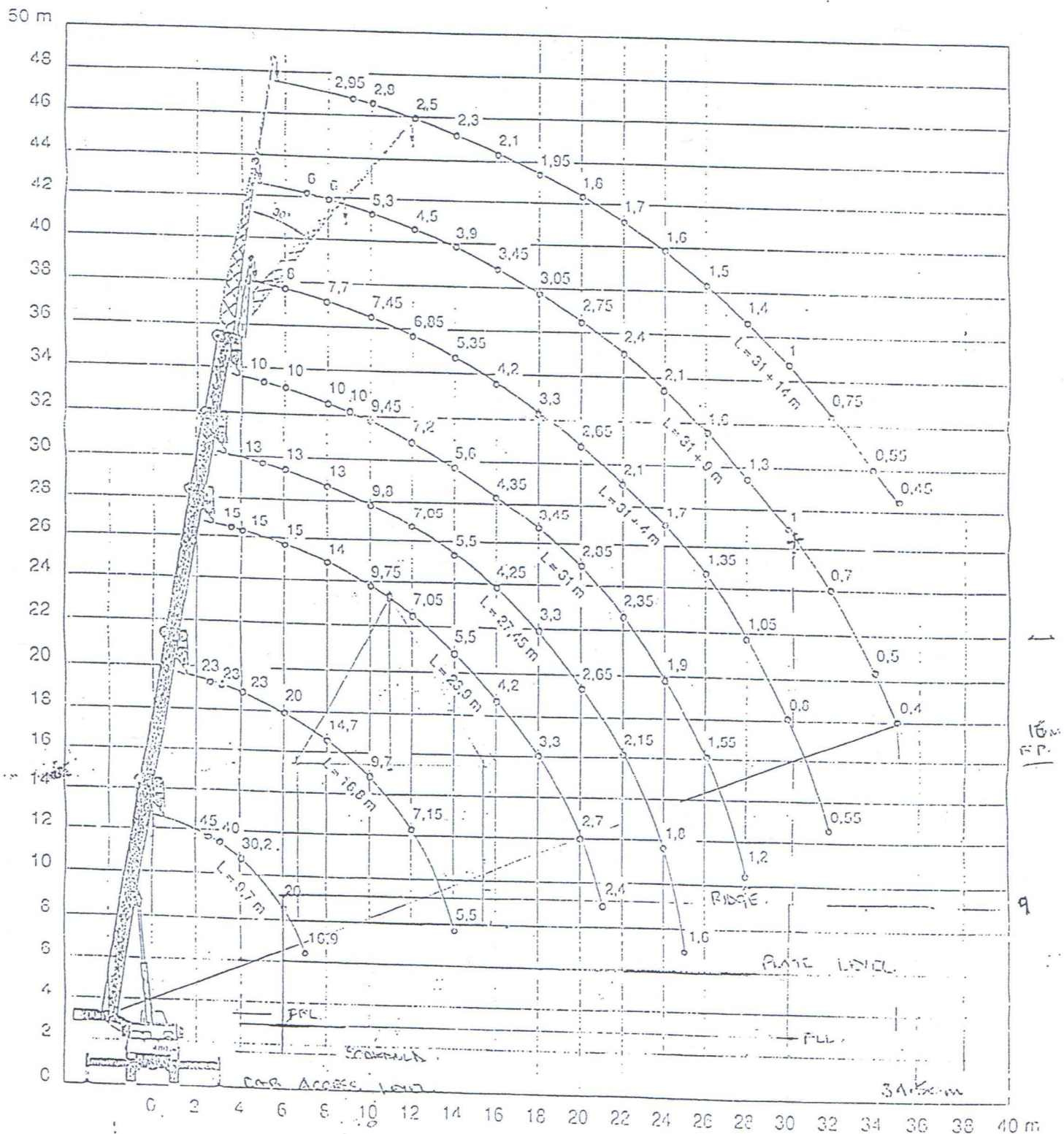

ATT480

EFFORT AU SOL SOUS L'APPUI
LE PLUS SOLICITE

Ground pressure under the most loaded support
Für die am meisten beladene abstützplatte beträgt
die maximale reaktion unter abstützplatte

BARS

CHARGES SUR STABILISATEURS EN EXTENSION TOTALE SUR 360°
SUR SOL HORIZONTAL ET DUR SUSPENSIONS BLOQUEES!
ON OUTRIGERS FULLY EXTENDED OVER 360° ON FIRM AND LEVEL GROUND (SUSPENSIONS LOCKED)

Hauptstützbeleg Schwenkbereich 360°
与吊钩区域同向全回转范围内
RÜCKSTÄHREN AUF FESTEM EBENEM UNTERGRUND (FEDERUNG VORN UND HINTEN BLOCKIERT)

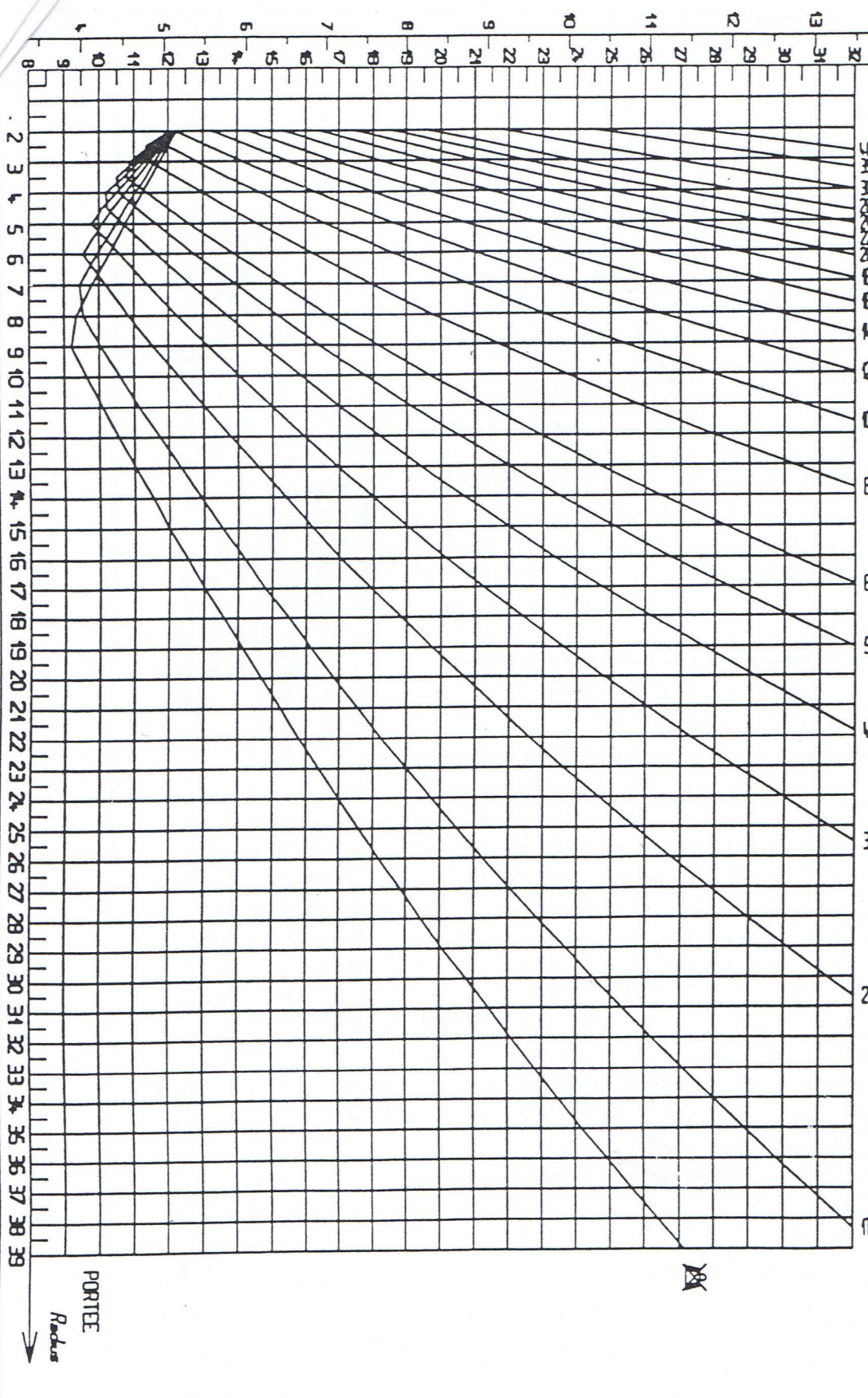

15-90

ATT480

EFFORT AU SOL SOUS L'APPUI
LE PLUS SOLICITE

*Ground pressure under the most loaded support
Für die am meisten beladene abstützplatte beträgt
die maximale reaktion unter abstützplatte*

TONNES
Tons

CHARGES SUR PNEUS (SUSPENSIONS RV ET RR BLOQUEES)
SUR L'ARRIERE D'UNE L'AXE SUR SOL HORIZONTAL ET DUR
FREE ON WHEELS (SUSPENSIONS LOCKED) OVER ROLL ON FIRM AND LEVEL GROUND (SUSPENSIONS LOCKED)
LAST AUF REIFEN AUF HINTERACHSE AUF FESTEM EBENEM UNTERGRUND (Federung vorn und hinten blockiert)

