

[5 P]^{PM} Plus

CLASSIC



[elevate to the highest power]^{pm}

[5 P] PM

New

EASY PLUS



_Distributore idraulico proporzionale Bosch
_Bosch Proportional hydraulic control valve block
_Distributeur hydraulique proportionnel Bosch
_Bosch Proportionaler Steuerventilblock
_Distribuidor hidráulico proporcional Bosch

_Radiocomando proporzionale palmare Easy Plus
_Radio Remote Control Proportional handy Easy Plus
_Radio control proportionnel Easy Plus
_Proportionale Funkfernsteuerung Easy Plus
_Radiocomando proporcional palmar Easy Plus



New

ADVANCE PLUS

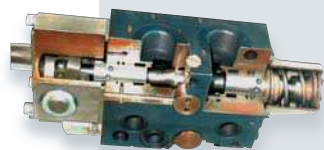

_Distributore idraulico proporzionale compensato Hawe.
_Hawe proportional hydraulic control valve block compensated.
_Distributeur hydraulique proportionnel Hawe compensé.
_Kompensierter proportionaler Steuerventilblock Hawe.
_Distribuidor hidráulico proporcional Hawe compensado.



_Radiocomando multifunzione Scanreco/Hetronic.
_Multifunction radio control Scanreco/Hetronic.
_Radiocommande multifonctions Scanreco/Hetronic.
_Funkfernsteuerung Scanreco/Hetronic.
_Radiocontrol multifunción Scanreco/Hetronic.

Tutte le gru PM sono coperte da polizza assicurativa internazionale per la responsabilità verso terzi.
All PM Cranes are covered by international insurance policy for civil liability third party.
Toutes les grues sont couvertes par une police d'assurance internationale de responsabilité civile envers tiers.
PM Krane sind durch eine internationale Haftpflichtversicherung gegen Dritte abgesichert.
Todas las grúas PM cuentan con una póliza de seguros internacional contra las responsabilidades civiles hacia terceros.

EN12999

CONFORME ALLE NORME DI SICUREZZA EU
IN ACCORDANCE TO THE EU SAFETY STANDARDS
CONFORME AUX NORMES DE SECURITE EU
GEMÄß EU SICHERHEITSRICHTLINIEN
CONFORME CON LAS NORMAS DE SEGURIDAD EU

H1B3

CLASSE DI SOLLECITAZIONE A FATICA H1B3
FATIGUE-TESTED IN CLASS H1B3
ESSAIS EN FATIGUE EN CLASSE H1B3
ERMÜDUNGSTEST NACH KLASSE H1B3
COMPROBACIÓN DE FATIGA EN LA CLASE H1B3

[3]

3 ANNI DI GARANZIA SULLE PARTI STRUTTURALI
3 YEARS OF WARRANTY ON THE STRUCTURAL PARTS
3 ANS DE GARANTIE SUR LES PARTIES STRUCTURELLES
3 JAHRE GARANTIE AUF STRUKTURBAUTEILE
3 AÑOS DE GARANTÍA EN LAS PARTES ESTRUCTURALES

[IIIA]

DICHIARAZIONE DI CONFORMITÀ DEL PRODUTTORE
DECLARATION OF CONFORMITY OF THE MANUFACTURER
DECLARATION DE CONFORMITE DU PRODUCTEUR
KONFORMITÄTSERKÄRUNG DES HERSTELLERS
DECLARACIÓN DE CONFORMIDAD DEL PRODUCTOR

PQS

SISTEMA DI VERNICIATURA DI QUALITÀ CERTIFICATA
CERTIFIED PAINTING QUALITY SYSTEM
SYSTEME DE PEINTURE DE QUALITÉ CERTIFIÉ
ZERTIFIZIERTES QUALITÄTS-LACKIERSYSTEM
SISTEMA DE BARNIZADO DE CALIDAD CERTIFICADA

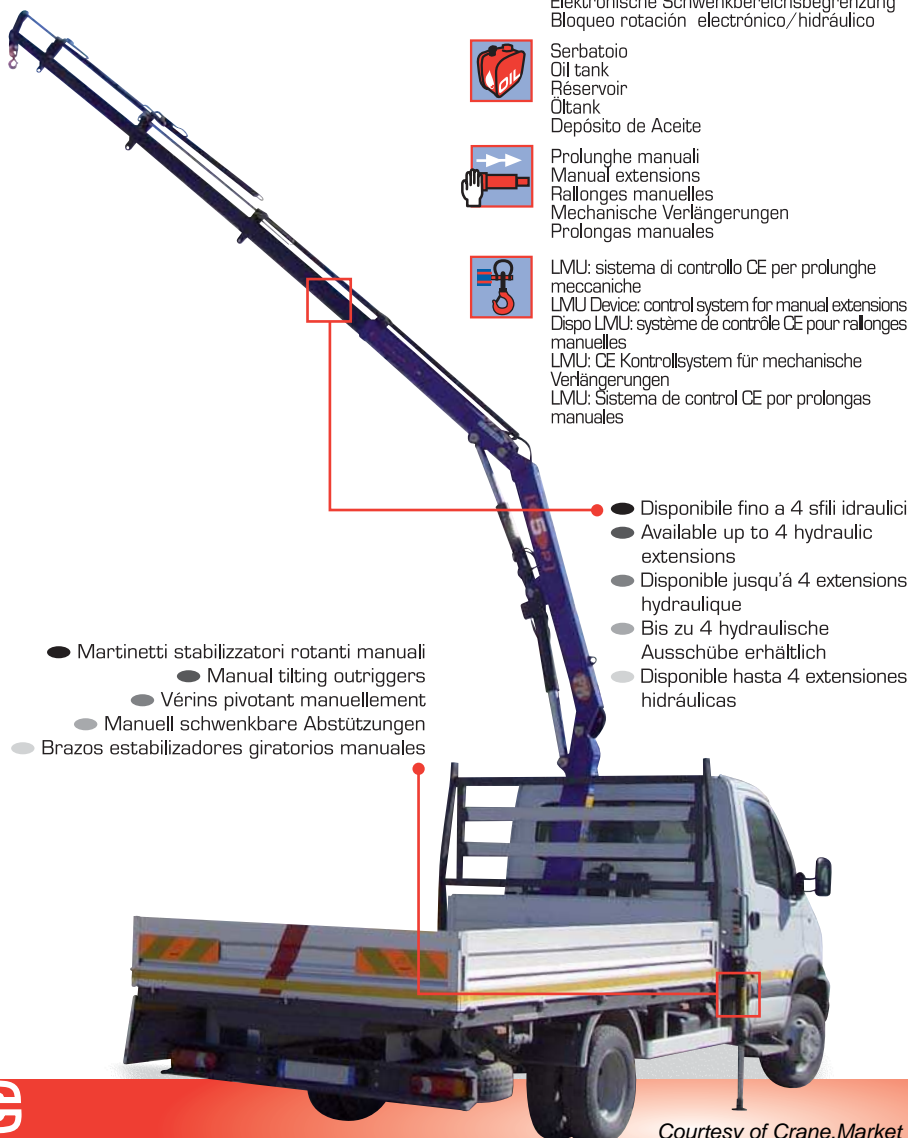

- Martinetti stabilizzatori rotanti manuali
- Manual tilting outriggers
- Vérins pivotant manuellement
- Manuell schwenkbare Abstützungen
- Brazos estabilizadores giratorios manuales

- Disponibile fino a 4 sfilii idraulici
- Available up to 4 hydraulic extensions
- Disponible jusqu'à 4 extensions hydraulique
- Bis zu 4 hydraulische Ausschübe erhältlich
- Disponible hasta 4 extensiones hidráulicas

EQUIPAGGIAMENTO DI SERIE - CONFIGURATION STANDARD EQUIPMENT - CONFIGURATION EQUIPEMENT STANDARD - SERIENMÄSSIG - EQUIPO DE SERIE



Radiocomando multifunzionale
Multifunction radio control
Radio commande multifonctions
Funkfernsteuerung
Radiomando multifunción



Cremafiliera
Slewing by rack
Rotation avec crémaillère
Zahnstangenschwenkwerk
Rotación con cremallera



Martinetti stabilizzatori rotanti manuali
Manual flip up outriggers
Vérins pivotant manuellement
Manuell schwenkbare Abstützylinder
Brazos estabilizadores giratorios manuales



Bracci stabilizzatori a sfilo manuale
Manual pull-out outrigger booms
Bras stabilisateurs avec extension manuelle
Manuelle Abstützungen
Brazos estabilizadores a salida manual



Distributore idraulico proporzionale Bosch
Bosch Proportional hydraulic control valve block
Distributeur hydraulique proportionnel Bosch
Bosch Proportionaler Steuerventilblock
Distribuidor hidráulico proporcional Bosch



Dispositivo automatico sicurezza stabilizzatori inserite
Safety Kit for outriggers
Dispositif de sécurité stabilisateurs
Sicherheitskit für die Abstützungen
Kit de Seguridad para estabilizadores

OPTIONAL



Scambiatore di calore
Oil cooler
Refroidisseur
Ölkühler
Enfriador de aceite



Canaline raccogli tubo
Activations with racks
Activations avec gouttières
Schlauchketten für Zusatzgeräte
Bandejas



Blocco Rotazione Elettroidraulico
Slewing limiter locking device electronic/hydraulic
Soupape d'arrêt rotation électronique/hydraulique
Elektronische Schwenkbereichsbegrenzung
Bloqueo rotación electrónico/hidráulico



Serbatoio
Oil tank
Réservoir
Öltank
Depósito de Aceite



Prolunghe manuali
Manual extensions
Rallonges manuelles
Mechanische Verlängerungen
Prolongas manuales



LMU: sistema di controllo CE per prolunghe meccaniche
LMU Device: control system for manual extensions
Dispo LMU: système de contrôle CE pour rallonges manuelles
LMU: CE Kontrollsystem für mechanische Verlängerungen
LMU: Sistema de control CE por prolongas manuales

5021 P

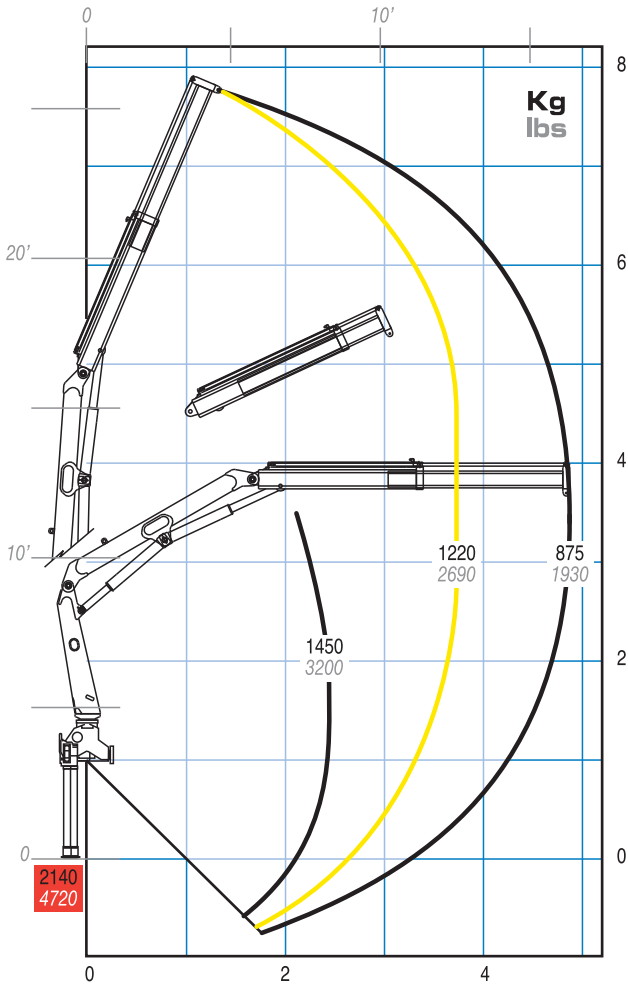

5022 P

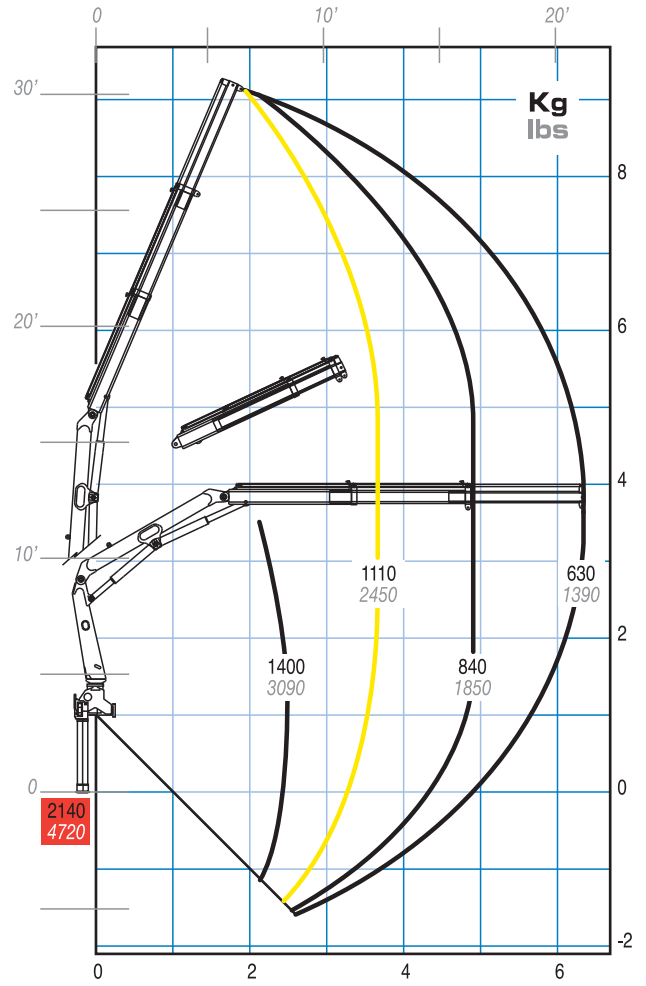

5023 P

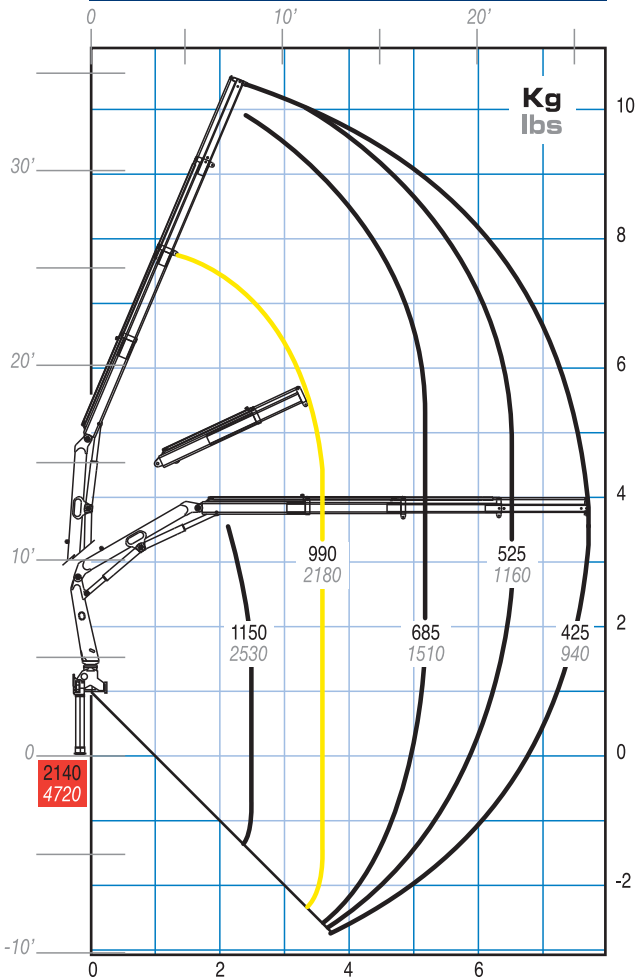

5024 P

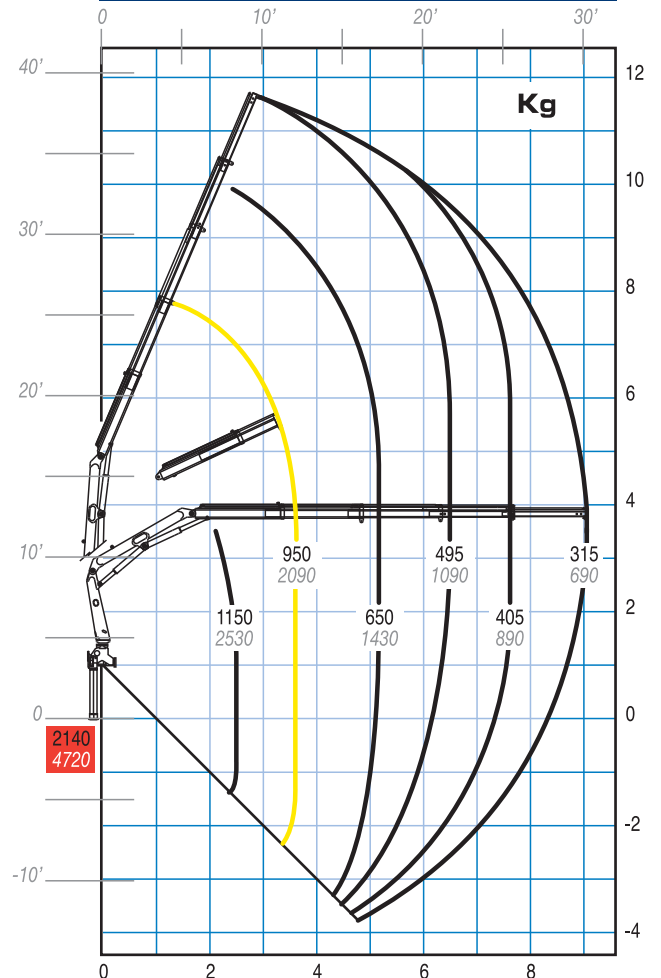

— Portata massima passante per l'orizzontale - Max. capacity from horizontal to vertical - Capacité maxi passant par l'horizontale - Max. Tragkraft von horizontal bis zu vertical - Máxima capacidad de la horizontal a la vertical
■ Portata massima nominale al gancho fisso - Max. nominal capacity at fixed hook - Capacité maxi nominale au crochet fixe - Max. Nenntragkraft an der inneren Hakenbefestigung - Capacidad máxima en el gancho fijo

mm
ft

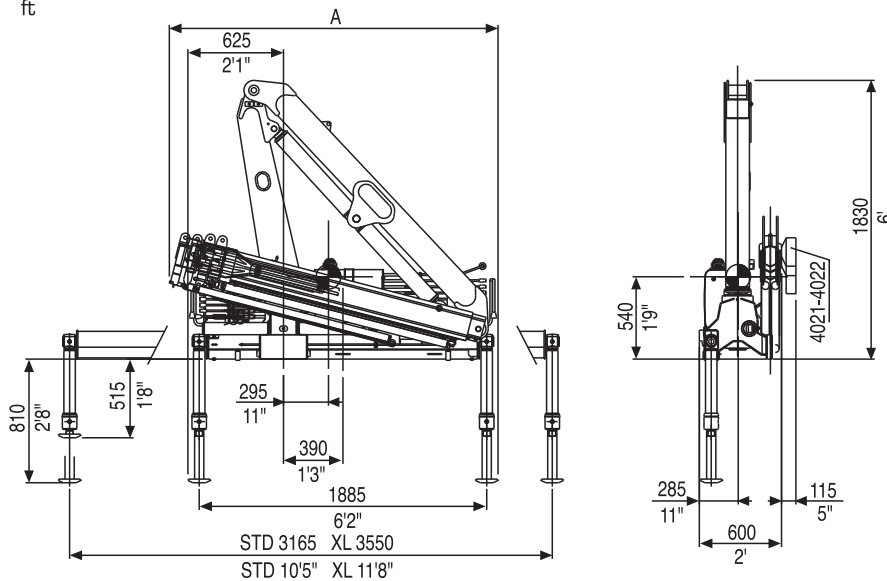

	5021 P	5022 P	5023 P	5024 P
A (mm)	2035	2035	2080	2160
A (ft)	6'8"	6'8"	6'10"	7'1"

Abbinamento gru/veicolo Trucking crane combination Accouplement grue/véhicule Kran zusammen mit LKW Combinación grúa/camión

PTT/GVV	5P		
3,5 ton			2 stabilizzatori STD 2 outriggers STD
5,0 ton			2 stabilisateurs STD 2 Abstützungen STD
6,0 ton			2 gatos de apoyo STD
6,5 ton			
7,5 ton			
8,0 ton			2 stabilizzatori XL 2 outriggers XL
10,0 ton			2 stabilisateurs XL 2 Abstützungen XL
12,0 ton			2 gatos de apoyo XL
13,5 ton			
15,0 ton			
18,0 ton			4 stabilizzatori 4 outriggers
19,0 ton			4 stabilisateurs 4 Abstützungen
26,0 ton			4 gatos de apoyo
32,0 ton			

PTT: Peso totale a terra - G.V.W. - P.T.A.C.
LKW Gesamtgewicht - Peso total del vehículo

	5021 P	5022 P	5023 P	5024 P	
Momento di sollevamento massimo - Maximum lifting moment - Moment de levage maxi - Max. Lastmoment - Momento de elevación máxima	tm ft. lbs	4,7 33970	4,2 30110	3,9 27860	3,6 26310
Sbraccio oleodinamico - Maximum hydraulic reach - Allongement hydraulique Hydraulische Reichweite, Standard - Alcance hidráulico orizzontale - horizontal - horizontal - horizontal verticale - vertical - vertical - vertical - vertical	m ft m ft	5,00 16'5" 7,80 25'7"	6,40 20'12" 9,15 30'0"	7,60 24'11" 10,40 34'1"	8,85 29'0" 11,65 38'3"
Sbraccio con prolunghe - Maximum reach with manual extensions - Allongement avec rallonges manuelles - Reichweite, manuelle Verlängerungen - Alcance con prolongas manuales orizzontale - horizontal - horizontal - horizontal verticale - vertical - vertical - vertical - vertical	m ft m ft	9,10 29'10" 11,70 38'5"	9,10 29'10" 11,70 38'5"	9,10 29'10" 11,70 38'5"	- - - -
Impianto oleodinamico - Hydraulic system - Circuit hydraulique - Hydraulikanlage - Sistema hidráulico portata raccomandata - recommended oil flow - débit recommandé - empfohlene Fördermenge - caudal requerido pressione massima - rated pressure - pression max - Betriebsdruck - presión máxima capacità del serbatoio - tank capacity - capacité du réservoir - Tankinhalt - capacidad del depósito de aceite	l/min gals/min Mpa Psi l Gals	10 3 26 3770 38 10	10 3 26 3770 38 10	10 3 26 3770 38 10	10 3 26 3770 38 10
Gruppo di rotazione - Slewing system - Rotation - Schwenksystem - Sistema de giro angolo di rotazione - slewing angle - angle de rotation - Schwenkbereich - ángulo de giro coppia di rotazione - slewing moment - couple de rotation - Schwenkmoment - momento de giro pendenza massima di lavoro - max. working heel - devers max de travail - max Arbeitsneigung - inclinación máxima de trabajo	° kNm ft. lbs %(°)	360 4,5 3320 7(4)	360 4,5 3320 7(4)	360 4,5 3320 7(4)	360 4,5 3320 7(4)
Peso della gru standard - Standard crane weight Poids de la grue standard - Eigengewicht - Peso de la grúa estandar Con serbatoio non rifornito - Empty oil tank - réservoir huile non garni - Leerer Öltank - depósito de aceite vacío	kg lbs	524 1155	562 1240	590 1300	608 1340

I dati tecnici possono essere aggiornati senza preavviso
Technical data can be revised without prior notice

Les données techniques peuvent être modifiées sans
preavis

Technische Änderungen vorbehalten
Reservado el derecho de modificaciones