



15.5

Courtesy of CraneMarket.com

classic



[elevate to the highest power]<sup>™</sup>

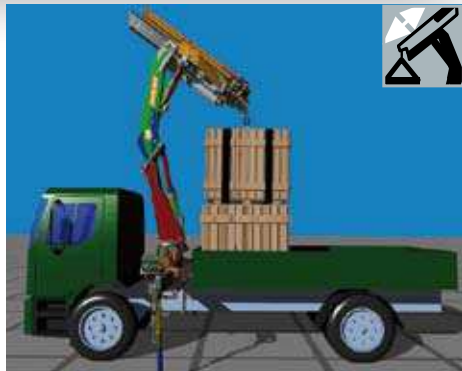

### LC (Long-Short) Telescopic System

PM crane in LC version, with first hydraulic retractable boom, optimizes the load positioning close to the column, and makes easy the placement of heavy and bulky loads.

### Système télescopique LC (Long-Court)

La version LC, le premier bras rétractable hydrauliquement, facilite le chargement du matériel lourd et encombrant en augmentant la hauteur disponible sous crochet et la capacité de soulèvement près de la colonne.

### Teleskopsystem LC (Lang-Kurz)

Die LC Ausführung, d.h. der hydraulisch einfahrbarem ersten Ausleger ermöglicht es sperrige Güter und große Lasten nah an mit Säule zu heben. Dies wird auch durch die hohe Hakenfreiheit ermöglicht.

### Sistema telescópico LC (Largo-Corto)

En la versión LC, el primer brazo se recoge hidráulicamente, así que permite de elevar, mover y también colocar material pesado y de gran tamaño cerca de la columna.

### SISTEMA TELESCOPICO LC (LUNGO-CORTO)

Gru PM, versione LC, con primo braccio retraibile idraulicamente, agevola le movimentazioni ingombranti e gravose a corto raggio, ottimizzando anche le posizioni di carico sotto colonna.



**Massimo potere di controllo** grazie al sistema elettronico PM Power Tronic dotato di display grafico LCD.

**Maximum control** thanks to the PM Power Tronic electronic system Endowed with graphic display LCD

**Contrôle maximal grâce** au dispositif électronique PM Power Tronic doué de display graphique LCD

**Bestmögliche Kontrolle** durch das elektronische PM Power Tronic System mit LCD Display

**Máximo poder de control** gracias al sistema electrónico PM Power Tronic dotado de display gráfico LCD

## OPTIONAL



**1** **RADIOCOMANDO MULTIFUNZIONE**  
**MULTIFUNCTION RADIO CONTROL**  
**RADIOCOMMANDE MULTIFONCTIONS**  
**FUNKFERNSTEUERUNG**  
**RADIOCONTROL MULTIFUNCIÓN**



**2** **DISTRIBUTORE IDRAULICO PROPORZIONALE**  
**COMPENSATO PVG 32**  
**CONTROL VALVE BLOCK COMPENSATED**  
**DISTRIBUTEUR HYDRAULIQUE PROPORTIONNEL**  
**COMPENSÉ**  
**HYDRAULISCHER PROPORTIONALER**  
**KOMPENSIRTER STEUERBLOCK**  
**DISTRIBUIDOR HIDRAULICO PROPORCIONAL**  
**COMPENSADO PVG 32**



**QUADRO COMANDI**  
**PANEL CONTROL**  
**TABLEAU DE BORD**  
**STEUEREINHEIT**  
**CUADRO DE MANDOS**

## 15.5

	Cremagliera - Slewing by rack - Rotation avec crémaillère - Zahnstangenschwenkwerk - Rotación con cremallera de giro	•
	Bracci stabilizzatori a sfilo manuale - Manual pull-out outrigger booms - Bras stabilisateur à extension manuelle - Manuelle Abstützungen - Brazos estabilizadores a salida manual	•
	Dispositivo automatico sicurezza stabilizzatori inserite - Safety Kit for outriggers - Dispositif de sécurité stabilisateurs - Sicherheitskit für die Abstützungen - Kit de Seguridad para estabilizadores *	•
	Uscita sequenziale sfilo bracci - Sequential extension booms' output - Sortie bras séquentiel - Anzahl der Ausschubzylinder - Salida secuencial de los brazos	•
	Scambiatore di calore aria/olio - Oil cooler - Refroidisseur d'huile - Ölkühler - Enfriador de aceite	○
	Radicomando Multifunzione - Multifunction radio control - Radio commande multifonctions - Funkfernsteuerung - Radiomando multifunción	○
	Distributore idraulico proporzionale - Proportional hydraulic control valve block - Distributeur hydraulique proportionnel - Hydraulische Proportional Steuerung - Distribuidor hidraulico proporcional	○
	Configurazione LC - LC configuration - Configuration LC - LC Ausführung - Configuración LC	○
	Antenna - Fly-Jib - Jib - Jib - Jib	○
	Verricello idraulico su gru - Hydraulic winch on crane - Treuils hydrauliques - Hydraulische Winde am Kran - Cabrestante hidraulico sobre la grúa	○
	Blocco rotazione - Slewing limiter - Limiteur de rotation - Drehblockierung - Paro rotación	○
	Canaline raccogli tubo - Hose racks supplementary - Supports tuyaux pour activation - Schlauchketten für Zusatzgeräte - Bandejas	○
	Prolunghe manuali - Manual extensions - Rallonges manuelles - Mechanische Verlängerungen - Prolongas manuales	○
	Serbatoio - Oil tank - Réservoir - Öltank - Depósito de Aceite	○
	LMU: sistema di controllo CE per prolunghe meccaniche - LMU Device: control system for manual extensions - Dispo LMU: système de contrôle CE pour rallonges manuelles LMU: CE Kontrollsystem für mechanische Verlängerungen - LMU: Sistema de control CE por prolongas manuales	○
	Posto in piedi - Stand up - Poste debout - Hochstand - Mando en altura	○
	Terzo punto di manovra - Stand up control - Poste debout - Hochstand - Mando en pié	○
	Posto in alto - Top seat - Siège à la colonne - Hochsitzsteuerung - Mando en altura	○
	Bracci stabilizzatori a sfilo idraulico - Hydraulic pull-out outrigger booms - Bras stabilisateur à extension hydraulique - Hydraulische Abstützungen - Brazos estabilizadores a salida hidráulica	○

\* di serie con CE • Equipaggiamento di serie - Standard configuration - Equipement standard - Serienmässig - Equipo de serie  
○ Disponibile come accessorio - Availables as optional - Als Zubehör erhältlich - Disponible como accesorio

15521

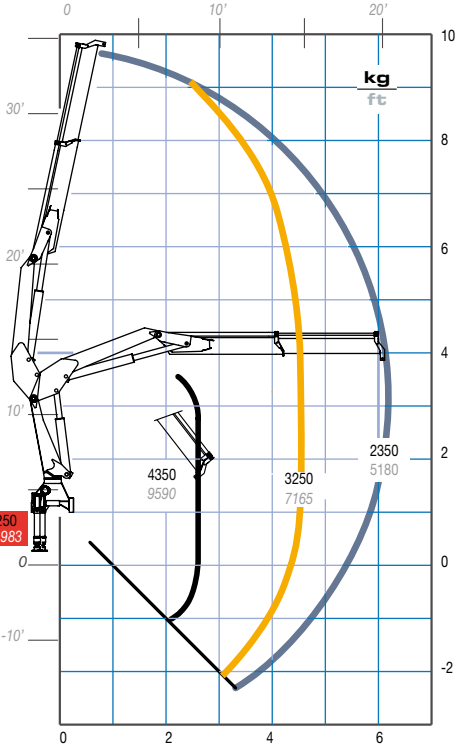

15522

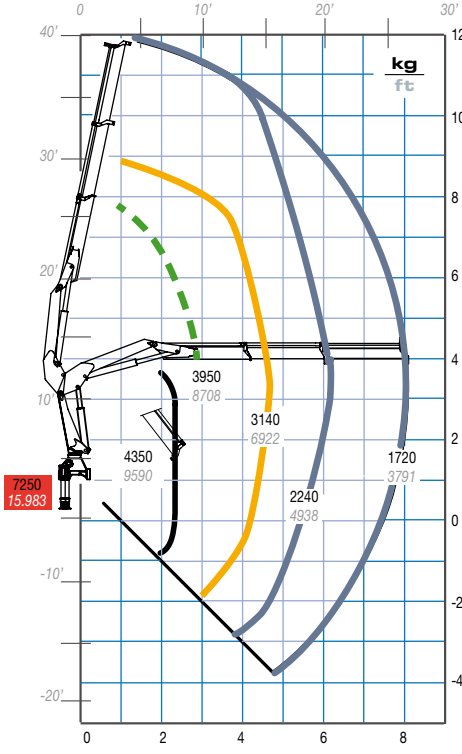

15523

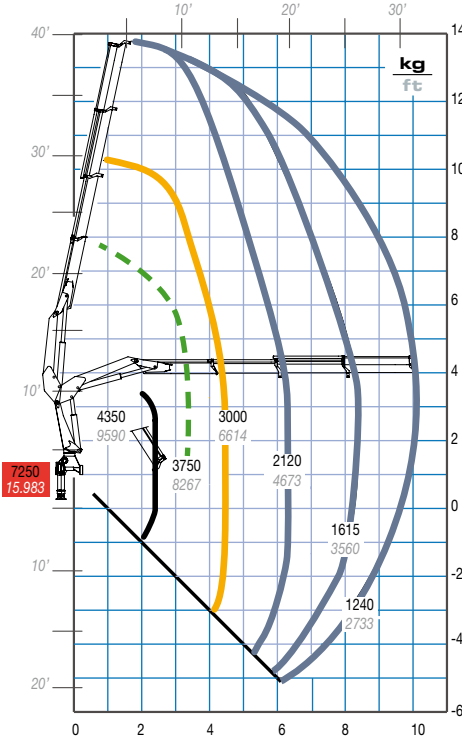

15524

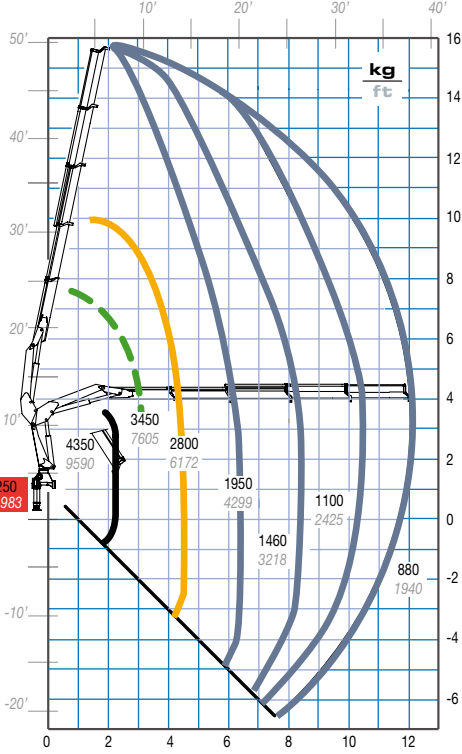

15525

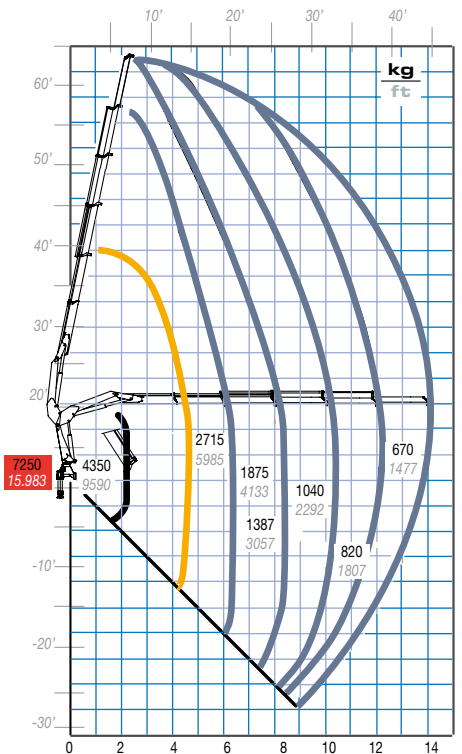

15523 + J12

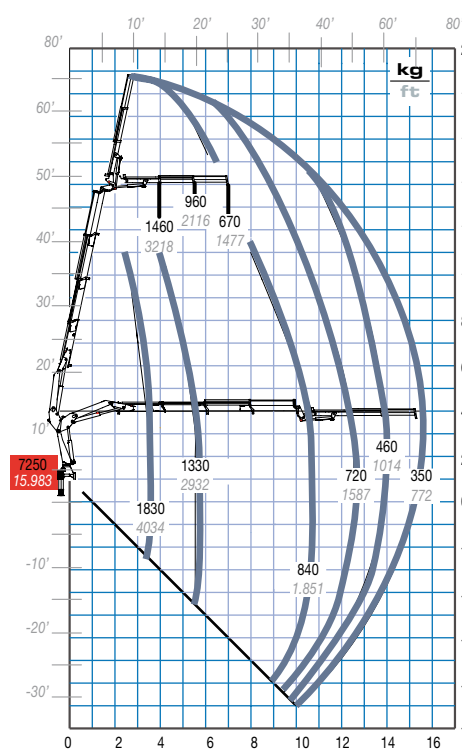

- Solo con gru in versione LC - Only with LC version - Seulement avec version LC - Nur LC Version - Solo con grúa en versión LC
- Portata massima nominale al gancho fisso - Max. nominal capacity with fixed hook - Capacité maxi nominale au crochet fixe - Max. Nenntragkraft an der inneren Hakenbefestigung - Capacidad máxima en el gancho fijo
- Portata massima passante per l'orizzontale - Max. capacity from horizontal to vertical - Capacité maxi passant par l'horizontale - Max. Tragkraft von horizontal bis zu vertical - Máxima capacidad de la horizontal a la vertical

**EN12999**  
 CONFORME ALLE NORME DI SICUREZZA EU  
 IN ACCORDANCE TO THE EU SAFETY STANDARDS  
 CONFORME AUX NORMES DE SECURITE EU  
 GEMÄß EU SICHERHEITSRICHTLINIEN  
 CONFORME CON LAS NORMAS DE SEGURIDAD EU

**3**  
 3 ANNI DI GARANZIA SULLE PARTI STRUTTURALI  
 3 YEARS OF WARRANTY ON THE STRUCTURAL PARTS  
 3 ANS DE GARANTIE SUR LES PARTIES STRUCTURELLES  
 3 JAHRE GARANTIE AUF STRUKTURBAUTEILE  
 3 AÑOS DE GARANTÍA POR LAS PARTES ESTRUCTURALES

**H1B3**  
 CLASSE DI SOLLECITAZIONE A FATICA H1B3  
 FATIGUE-TESTED IN CLASS H1B3  
 ESSAIS EN FATIGUE EN CLASSE H1B3  
 ERMÜDUNGSTEST NACH KLASSE H1B3  
 COMPROBACIÓN DE FATIGA EN LA CLASE H1B3

**Abbinamento gru/veicolo - Trucking crane combination - Accouplement grue/véhicule - Kran zusammen mit LKW Combinación grúa/camión**

PTT/GVV	<b>16.5S</b>	PTT/GVV	<b>16.5S</b>
<b>15,0 TON</b>	<b>4</b>	<b>26,0 TON</b>	<b>2 STD</b>
<b>18,0 TON</b>	<b>2 XL</b>	<b>32,0 TON</b>	<b>2 STD</b>
<b>19,0 TON</b>	<b>2 STD</b>		

<b>2 STD</b>		2 stabilizzatori STD 2 outriggers STD 2 stabilisateurs STD 2 Abstützungen STD 2 gatos de apoyo STD
<b>2 XL</b>		2 stabilizzatori XL 2 outriggers XL 2 stabilisateurs XL 2 Abstützungen XL 2 gatos de apoyo XL

<b>4</b>		4 stabilizzatori 4 outriggers 4 stabilisateurs 4 Abstützungen 4 gatos de apoyo
----------	--	--

PTT: Peso totale a terra - G.V.W. - P.T.A.C.  
 LKW Gesamtgewicht - Peso total del vehículo



# 15.5

mm  
ft

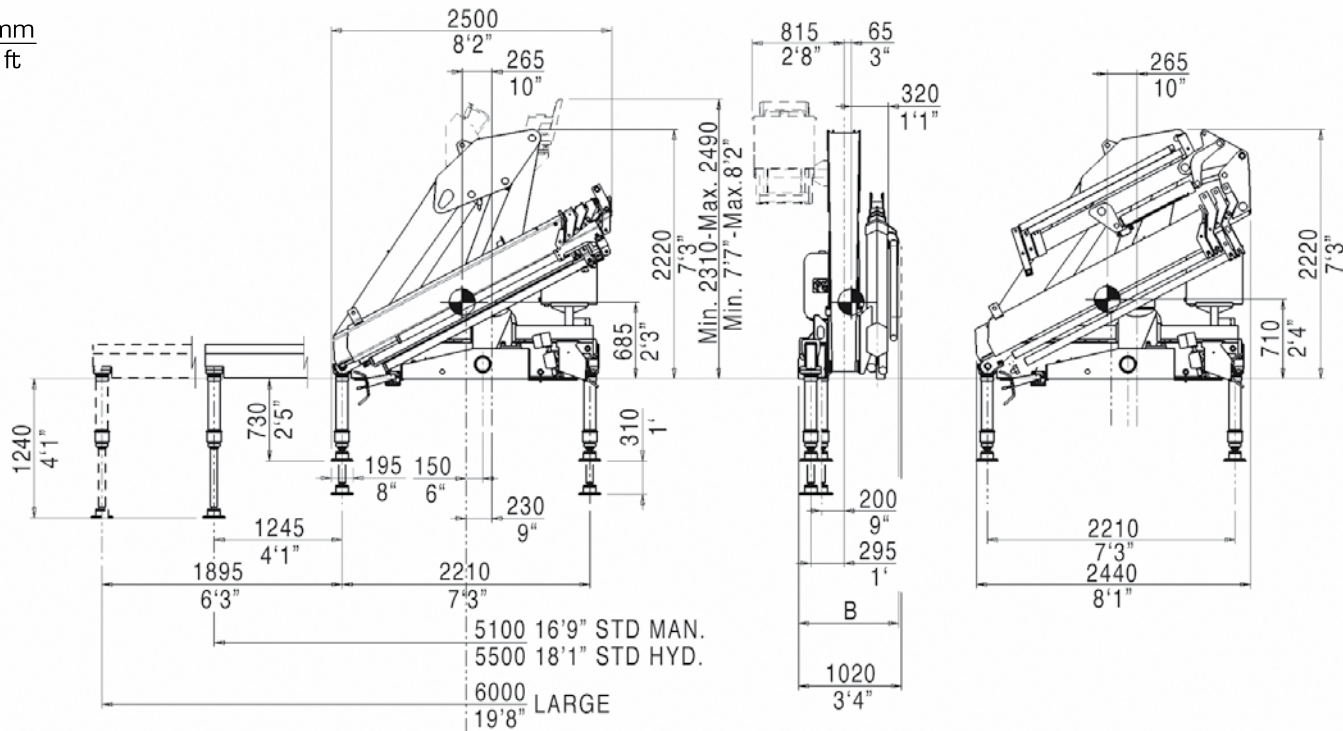

	15521	15522	15523	15524	15525
A (mm)	2410	2410	2410	2460	2500
A (ft)	7'11"	7'11"	7'11"	8'1"	8'2"
B (mm)	860	860	860	860	980
B (ft)	2'10"	2'10"	2'10"	2'10"	3'3"

# 15.5

		15521	15522	15523	15524	15525	15525 +J12
Momento di sollevamento massimo - Maximum lifting moment - Moment de levage maxi - Max. Lastmoment - Momento de elevación máxima	tm ft lbs	14,7 103000	14,3 100050	13,8 93830	13,2 92470	13 92080	-
Sbraccio oleodinamico - Maximum hydraulic reach - Allongement hydraulique Hydraulische Reichweite, Standard - Alcance hidráulico	m	6,50	8,45	10,45	12,40	14,40	15,65
orizzontale - horizontal - horizontal - horizontal	ft	21'4"	27'9"	34'3"	40'8"	47'3"	51'4"
verticale - vertical - vertical - vertikál - vertical	m	9,80	11,75	13,70	15,60	17,70	18,75
	ft	32'2"	38'7"	44'11"	51'2"	58'1"	61'6"
Sbraccio con prolunghe - Maximum reach with manual extensions - Allongement avec rallonges manuelles - Reichweite, manuelle Verlängerungen - Alcance con prolongas manuales	m	-	-	16,05	16,15	16,15	17,15
orizzontale - horizontal - horizontal - horizontal	ft	-	-	52'8"	52'12"	52'12"	56'3"
verticale - vertical - vertical - vertikál - vertical	m	-	-	19,25	19,35	19,35	20,20
	ft	-	-	63'2"	63'6"	63'6"	66'3"
Impianto oleodinamico - Hydraulic system - Circuit hydraulique - Hydraulikanlage - Sistema hidráulico	l/min gals/min	30 8	30 8	30 8	30 8	30 8	30 8
portata raccomandata - recommended oil flow - débit recommandé - empfohlene Fördermenge - caudal requerido							
pressione massima - rated pressure - pression max - Betriebsdruck - presión máxima	Mpa Psi	30 4280	30 4280	30 4280	30 4280	30 4280	30 4280
capacità del serbatoio - tank capacity - capacité du réservoir - Tankinhalt - capacidad del depósito de aceite	l Gals	88 23	88 23	88 23	88 23	88 23	88 23
Gruppo di rotazione - Slewing system - Rotation - Schwenksystem - Sistema de giro	°	400	400	400	400	400	400
angolo di rotazione - slewing angle - angle de rotation - Schwenkbereich - ángulo de giro							
coppia di rotazione - slewing moment - couple de rotation - Schwenkmoment momento de giro	kNm ft lbs	16 11800	16 11800	16 11800	16 11800	16 11800	16 11800
pendenza massima di lavoro - max. working heel - devers max de travail - max Arbeitsneigung - inclinación máxima de trabajo	%(°)	8,7(5)	8,7(5)	8,7(5)	8,7(5)	8,7(5)	0
Peso della gru standard - Standard crane weight	kg	1770	1880	1990	2080	2180	2280
Poids de la grue standard - Eigengewicht - Peso de la grúa estandar	lbs	3905	4145	4390	4590	4810	5030
Con serbatoio non rifornito - Empty oil tank - réservoir huile non garni - Leerer Öltank - depósito de aceite vacío	kg lbs	- -	2030 4480	2140 4720	2230 4920	- -	- -
Versione LC - LC version - LC version - LC Version - versión LC							

I dati tecnici possono essere aggiornati senza preavviso. - Technical data can be revised without prior notice. - Les données techniques peuvent être modifiées sans preavis. - Technische Änderungen vorbehalten. - Reservado el derecho de modificaciones.

