

PLS



PLS 820

SUPERSTRUCTURE SPECIFICATION

Superstructure

Welded steel fabricated frame on which the telescopic jib, winch, slewing unit, derricking cylinders, counterweight and operator's cab are mounted. The Superstructure is capable of continuous slewing in either direction and rotates on a slew bearing. A central hydraulic & pneumatic rotary joint and electrical slip ring assembly are provided between superstructure and chassis.

Boom

Construction - 3 section boom made from high tensile

Telescoping - Fully steel powered, fully synchronized boom extending from 8.8 m to 21.7 m using cylinder and chain arrangement. Hydraulic overcentre valve provided for controlled retraction and automatic load holding.

Derricking - Double acting hydraulic cylinder fitted with Integral pilot operated counter balance safety check valve.

Boom Angle - max 75°, min (-) 1.25°

Derricking Speed - 25 sec

Slew System

Hydraulic motor driven planetary reduction unit with slew pinion provides 360° continuous slew in either direction. Counter balance valve incorporated for smooth jerk free braking.

Brake - Spring applied, hydraulically released multi-plate brake.

Slew Speed - Maximum 3 rpm.

Slew Ring - External teeth slew ring grease packed and sealed for long life. Mounted on precision machined surface to prevent distortion of the slew ring.

Hoist System

It is driven by a hydraulic motor through a planetary gear reduction unit for hoisting. Counter balance valve provided for controlled lowering. It has fail safe multi disk brakes released hydraulically. Hoist drum with grooves, 16 mm wire rope. Overlowering switch provided with hydraulic cut-off.

Hoist Brake - Spring applied, hydraulically released multi plate brake.

Line speed - 60 m/min

Operator's Cabin

Steel frame construction with lockable sliding door to permit easy access. Large glazed areas with rear opening windows allow maximum all round vision. Ergonomically positioned joystick levers on either side of seat control all craning motions. Instrumentation located on console in front of operator. Seat is adjustable. All windows are fitted with toughened glass and lockable sliding door. Cabin is fitted with interior light, electric wiper on the windscreen, electric horn and fan. Slew locking arrangement is controlled from inside the cabin.

Crane Controls

Joystick controls for slew, telescoping, hoisting and derricking with independent or simultaneous operation.

Control Valves

All control valves are hydraulically operated and located for easy maintenance. These are operated by pilot pressure supplied through joystick control levers located inside cabin. Electro hydraulic solenoid valves control hydraulic outriggers.

Instrumentation

Audible and visual warning for engine and torque converter temperature and air pressure, alternator, parking brake, directional indicators, air pressure gauge and engine hour meter gauge.

Safety System

Load Moment Indicator - Microcontroller based LMI is fitted on the crane along with angle & length sensors. Display / CPU is mounted inside the operator's cab. Indicator for load, safe working load, radius, boom angle, boom length and % SWL margin are available on the display unit. Audio visual warnings for approach overload, overhoist, rope break are provided. In case of overload hydraulic cut-off is activated by the LMI.

Other Safety Features - Load holding lock valves on cylinders for protection against hose burst or power failure. Motion control overcentre valves for smooth movement of loads.

Electricals - 24 Volts negative earth.

Optional Equipments

- Four part telescoping jib with two fully powered position sections.
- 7.0 m side folding lattice jib extension with 2 fall hook block.
- 16.00 x 25 Tyres.
- Jib nose hook.
- Cab heater
- Cab AC
- Spare wheel / tyre
- Man carrying basket
- Flood light

Tool Kit - Standard maintenance tool kit.

CARRIER SPECIFICATION

Chassis

High grade steel, welded box type, torsion resistant structure with outrigger boxes.

Drive

4 x 4 / 4 x 2 wheel drive with four wheel steer.

Outriggers

Four hydraulically operated telescopic outrigger beams with vertical hydraulic jacks fitted with hydraulic lock valves. Vertical jacks fitted with removable, stowable outrigger feet. Outrigger controls located in operator's cab. Independent control for outriggers with individual beam and jack operation.

Engine

Suitable diesel engine of adequate horsepower.

Transmission

Engine mounted full power shift transmission having multiple speeds forward and reverse. Oil cooler provided to maintain oil temperature within limits.

Fuel Tank

Fabricated tank with an oil capacity of 375 litres.

Hydraulic Pump

Tandem gear pump driven from transmission, provide flow to the hydraulic system.

Hydraulic System

All crane operations are hydraulically controlled through pilot pressure available from hydraulic joystick valves. Outriggers are operated through electro-hydraulic valves. Pressure relief valves are provided to protect the pumps and hydraulic system components. Motion control valves / lock valves provide smooth crane operations.

Hydraulic Tank

Fabricated tank with an oil capacity of 450 litres.

Front Axle

Drive / Steer with planetary wheel hub and rigid mounting with chassis.

Rear Axle

Drive / Steer with planetary wheel hubs and mounted on oscillating cradle.

Steering

Hydraulic power steering unit supplies oil to the steering cylinders of axles. Automatically corrected steering when superstructure is in reverse position.

Brakes

Service - Foot operated compressed air over hydraulic service brakes.

Parking - Hydraulically released fail safe parking brake.

Wheels Tyres

14.00 x 25 with earthmover tread pattern.

Max. Speed - 35 kmph

Max. Gradeability - 50%

Weight Distribution

Front - 11500 Kgs

Rear - 10200 Kgs

GVW - 21700 Kgs

GENERAL DIMENSIONS

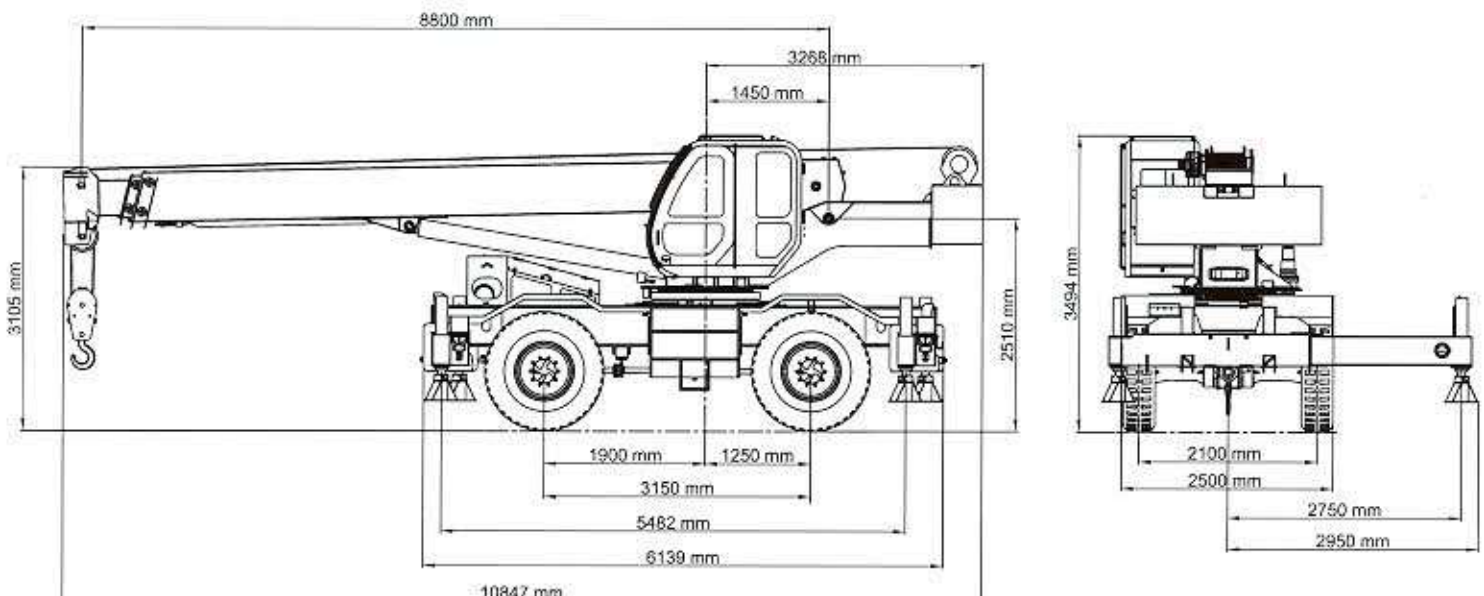

HEIGHT & LIFT

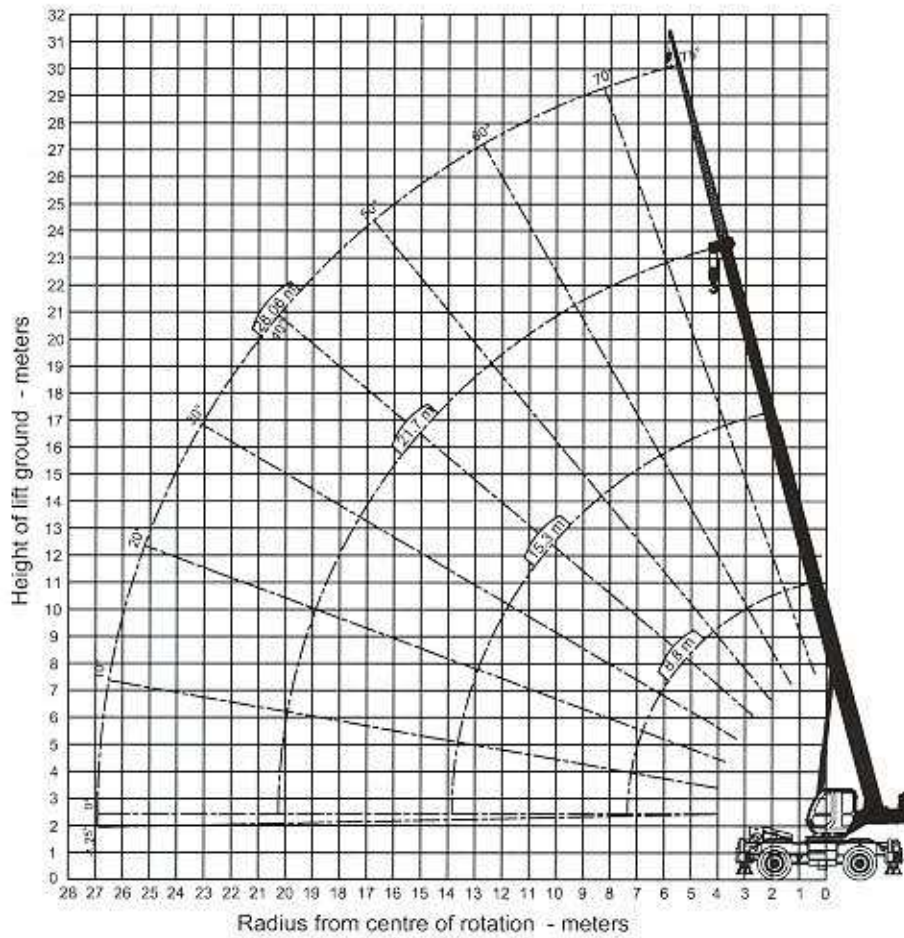

OUTREACH

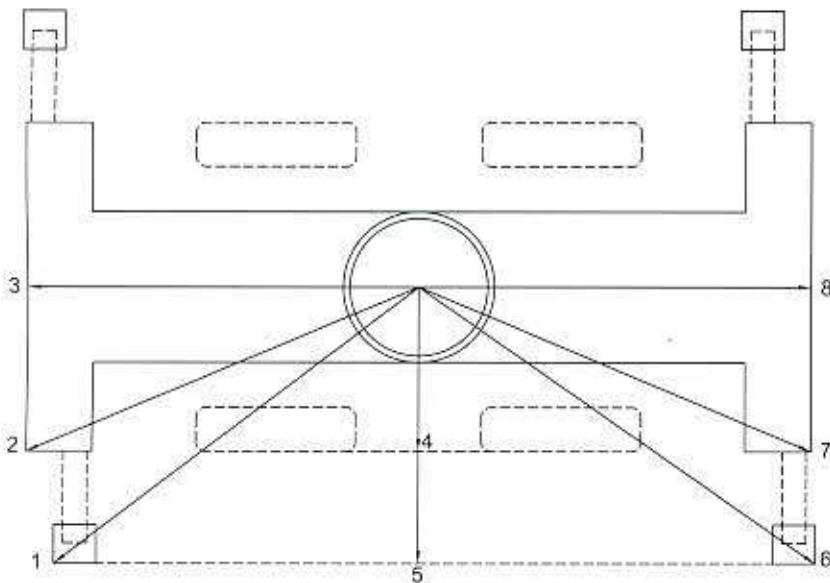

The outreach is obtained by deducting 'd' from the radius in any jib position.

Jib position	Distance (meters)
1	4.45
2	3.36
3	4.36
4	1.25
5	2.96
6	3.9
7	3.0
8	2.7

LOAD CHART

3 SECTION JIB RADIUS m	360° BLOCKED CONDITION						FREE-ON-WHEEL (STATIC)				OVER FRONT ONLY	
							360°		OVER FRONT		UP TO 5 kmph (3 mph)	
	JIB CLOSED	JIB EX- TENDED	JIB EX- TENDED	JIB EX- TENDED	JIB EX- TENDED	FLY JIB (Length 7m)	JIB CLOSED	JIB LENGTH	JIB CLOSED	JIB LENGTH	JIB CLOSED	JIB LENGTH
8.8 m	8.8 -12.5m	12.5-15.3m	15.3-18.5m	18.5-21.7m	15.8-28.06m	8.8 m	8.8 -15.3m	8.8 m	8.8 -15.3m	8.8 m	8.8 -15.3m	
m	Kg	Kg	Kg	Kg	Kg	Kg	Kg	Kg	Kg	Kg	Kg	Kg
3.0	20,000		19,300	16,200	12,900		8,500	8,000	13,000	12,600	11,700	11,200
3.5	20,000	20,000	18,500	16,200	12,900		7,000	6,700	11,400	11,100	10,200	9,650
4.0	18,000	17,900	17,600	16,000	12,900		6,200	5,700	10,100	9,700	8,800	8,500
4.5	15,900	15,700	15,700	14,900	12,700	5,500	5,300	4,900	8,900	8,600	7,700	7,500
5.0	14,100	14,000	14,000	13,900	12,500	5,500	4,600	4,200	8,000	7,700	7,000	6,600
6.0	11,600	11,600	11,500	11,500	10,800	5,500	3,500	3,500	6,500	6,200	5,600	5,200
7.0	8,200	8,100	8,100	8,100	8,100	5,500	2,800	2,500	5,400	4,900	4,500	4,300
8.0		7,700	7,700	7,700	7,700	5,500		1,750		3,800		3,400
9.0		6,800	6,700	7,000	6,700	5,500		1,250		2,900		2,900
10.0		5,500	5,400	5,700	5,700	4,800		850		2,300		2,300
11.0		4,600	4,500	4,500	4,500	3,900				1,700		1,700
12.0			3,700	4,000	4,000	3,300				1,300		1,300
13.0			2,700	-	-					800		850
14.0				2,900	2,900	2,500						
16.0				2,100	2,100	2,100						
18.0					1,600	1,600						
20.0					1,200	1,200						
22.0						1,000						

Notes:

- Lifting capacities are based on 85% duty as per IS 4573.
- Lifting capacities at max radius is based on boom angle not less than 15°.
- Weight of slings, hook block or any lifting device must be added to the load being lifted.
- In blocked condition, outriggers are fully extended and vertical jacks supported on firm ground with tyres lifted off the ground and chassis is levelled.
- When performing crane duties in F.O.W. conditions, it must be ensured that all tyres are filled to specified air pressure and floating axle is locked.
- Crane should not be operated during high wind conditions which affect stability.
- For over front capacity on wheels, boom must remain within +/- 5° from the longitudinal axis of the vehicle.
- The jib can be telescoped in / out with the load suspended, provided it is within the capacity as per the load chart.
- With fly jib in erected condition, the main boom capacities shall be reduced by 700 kgs.
- If the hook block is fitted to the main boom, the fly jib capacities must be reduced by the weight of the hook block of the boom.
- Proper duty must be selected in the safe load system before lifting the loads.
- All dimensions are within ±5%.

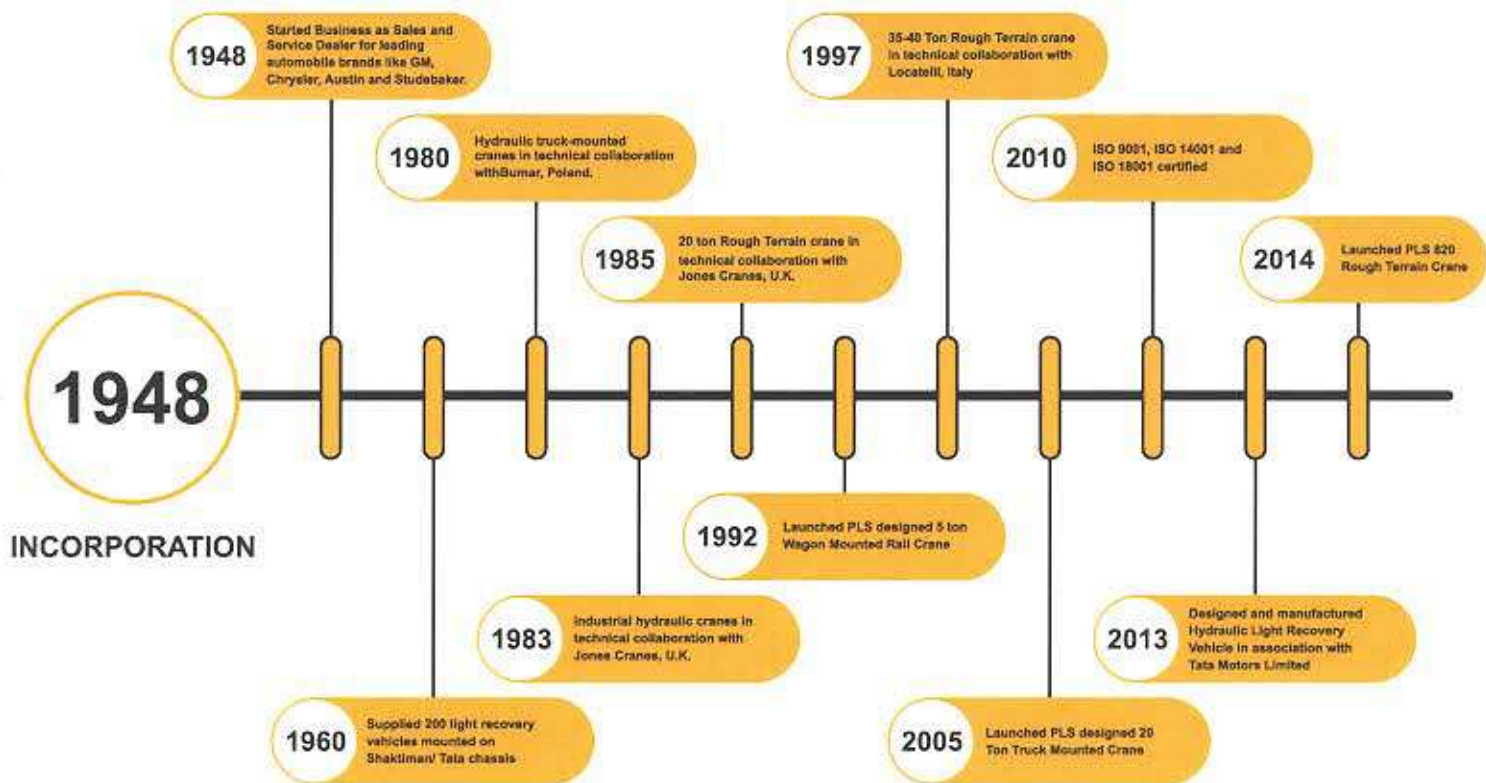

Pearey Lall & Sons (E.P.) Ltd, (PLS) is a renowned name in the Crane Industry. Cranes manufactured at PLS are designed keeping in mind the state-of-the-art technology and engineering excellence.

Through years of experience and various collaborations, PLS has offered a variety of well-designed solutions for diverse challenges in material handling. We manufacture cranes that meet the required quality, safety and operational standards.

ISO 9001
Quality Management Systems

ISO 14001
Environment Management Systems

ISO 18001
Occupational Health and Safety Advisory Services



Our Service Centers

- Jodhpur
- Mumbai
- Kolkata
- Chandigarh
- Vishakhapatnam
- Kochin
- Guwahati

Pearey Lall & Sons (E.P.) Ltd.

www.plsindia.com

Works

9th Milestone, G. T. Road, Sahibabad,
Ghaziabad 201007, U.P.
Phone: +91 120 417 7900 / 7907
Fax: +91 120 4177991
Email: sales@plsindia.com



Courtesy of Crane.Market