

Pecco SK 280-16

TOWER CRANE

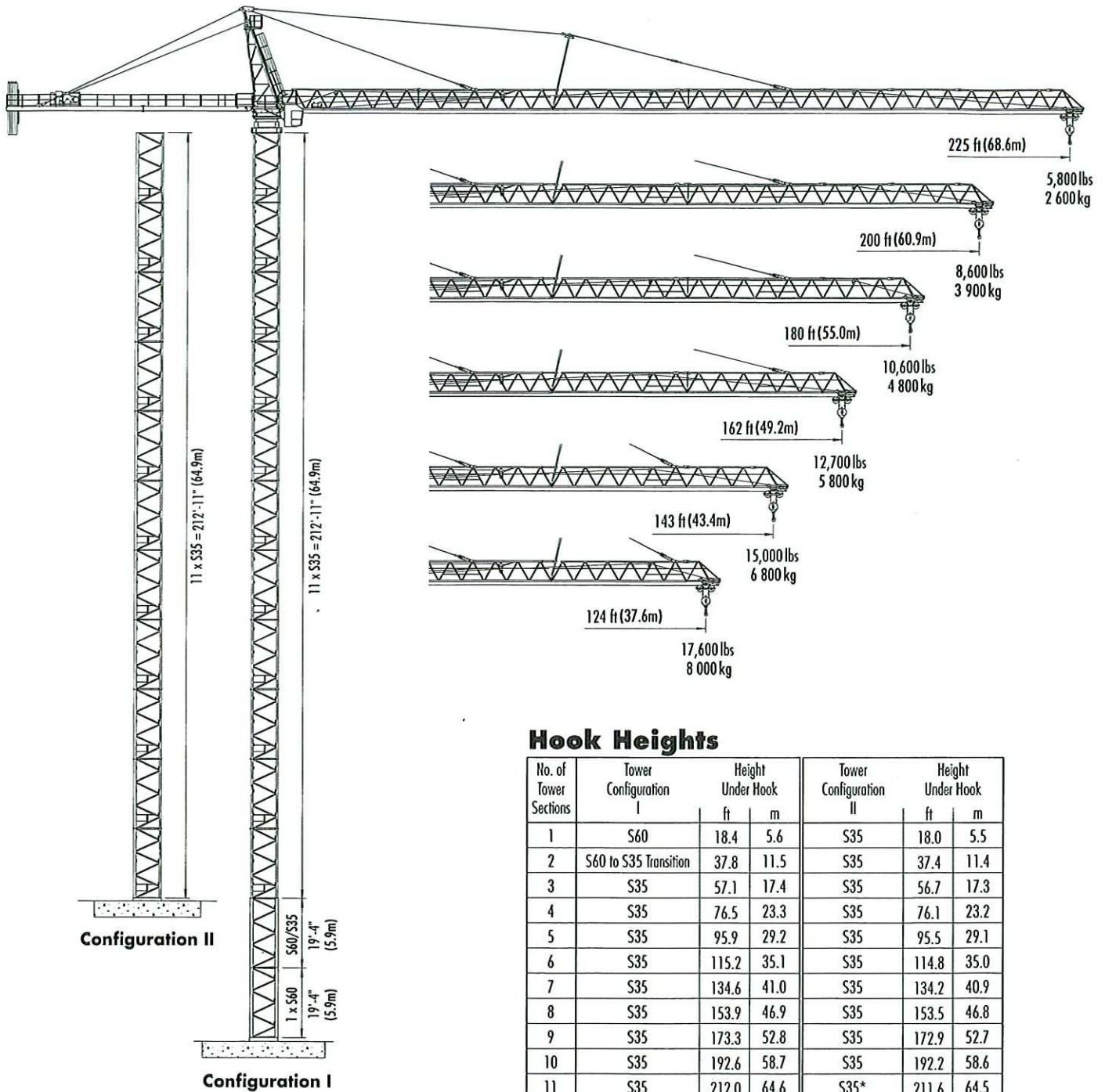

**STATIONARY
FREESTANDING**











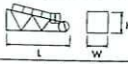
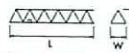

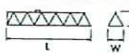
Hook Heights

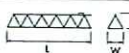
No. of Tower Sections	Tower Configuration I	Height Under Hook		Tower Configuration II	Height Under Hook	
		ft	m		ft	m
1	S60	18.4	5.6	S35	18.0	5.5
2	S60 to S35 Transition	37.8	11.5	S35	37.4	11.4
3	S35	57.1	17.4	S35	56.7	17.3
4	S35	76.5	23.3	S35	76.1	23.2
5	S35	95.9	29.2	S35	95.5	29.1
6	S35	115.2	35.1	S35	114.8	35.0
7	S35	134.6	41.0	S35	134.2	40.9
8	S35	153.9	46.9	S35	153.5	46.8
9	S35	173.3	52.8	S35	172.9	52.7
10	S35	192.6	58.7	S35	192.2	58.6
11	S35	212.0	64.6	S35*	211.6	64.5
12	S35	231.3	70.5			
13	S35*	250.7	76.4			

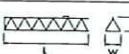
* Lower the top climbing unit to base of crane prior to operating crane at maximum hook height. Other tower combinations are possible, contact Morrow Equipment for additional information.

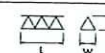
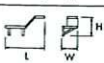
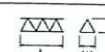
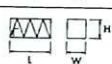
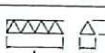
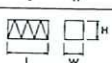
Component List

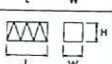
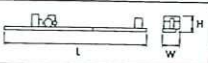
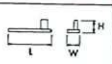
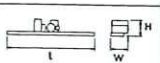
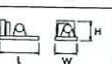
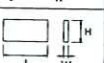
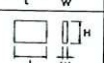
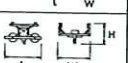
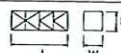
Pecco SK 280-16

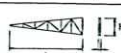
Description	Dimensions L x W x H	Weight	Description	Dimensions L x W x H	Weight
Tower Top 	30'-0" x 6'-8" x 7'-3" 9.14m x 2.03m x 2.21m	6,620 lbs 3 000 kg	Jib Section ① 	38'-9" x 6'-1" x 6'-2" 11.8m x 1.85m x 1.88m	6,600 lbs 3 000 kg
Turntable (Complete) Upper & Lower Part 	9'-4" x 10'-0" x 10'-2" 2.84m x 3.03m x 3.1m	19,800 lbs 8 980 kg	Jib Section ② 	38'-9" x 6'-1" x 5'-11" 11.8m x 1.85m x 1.8m	4,400 lbs 2 000 kg
Turntable Upper Part ¹ 	9'-4" x 6'-10" x 7'-0" 2.84m x 2.08m x 2.13m	10,200 lbs 4 625 kg	Jib Section ③ 	38'-9" x 6'-1" x 5'-11" 11.8m x 1.85m x 1.8m	3,000 lbs 1 360 kg
Turntable Lower Part ² 	8'-8" x 10'-0" x 3'-2" 2.65m x 3.03m x 0.97m	9,600 lbs 4 355 kg	Jib Section ④ 	38'-9" x 6'-1" x 5'-11" 11.8m x 1.85m x 1.8m	3,000 lbs 1 360 kg
Operator's Cab 	5'-11" x 4'-3" x 7'-1" 1.8m x 1.3m x 2.16m	900 lbs 410 kg	Jib Section ⑤ 	19'-9" x 6'-1" x 5'-11" 6.02m x 1.85m x 1.8m	1,600 lbs 725 kg
Cab Access Platform 	12'-8" x 5'-7" x 2'-9" 3.85m x 1.7m x 0.85m	1,000 lbs 454 kg	Jib Section ⑥ 	19'-9" x 6'-1" x 5'-11" 6.02m x 1.85m x 1.8m	1,200 lbs 545 kg
Tower Section S35 	19'-5" x 7'-10" x 8'-0" 5.92m x 2.4m x 2.44m	8,900 lbs 4 040 kg	Jib Section ⑦ 	26'-0" x 6'-1" x 5'-11" 7.9m x 1.85m x 1.8m	1,400 lbs 635 kg
Transition Section S60 to S35 	19'-5" x 7'-11" x 7'-11" 5.92m x 2.41m x 2.41m	9,930 lbs 4 500 kg	Jib Section ⑧ 	9'-11" x 6'-4" x 7'-1" 3.02m x 1.93m x 2.16m	1,000 lbs 455 kg
Tower Section S60 	19'-5" x 7'-11" x 7'-11" 5.92m x 2.41m x 2.41m	9,930 lbs 4 500 kg	Jib Assembly Part 1 ⁶ for all Jib Assemblies ①②	76'-2" x 6'-1" x 6'-2" 23.2m x 1.85m x 1.88m	15,750 lbs 7 145 kg
Counterjib ³ (Complete) 	69'-3" x 9'-1" x 8'-4" 21.1m x 2.77m x 1.8m	20,220 lbs 9 170 kg	Jib Assembly Part 2 ⁷ 225-ft (68.6m) ③④⑤⑥⑦⑧	149'-1" x 6'-4" x 7'-1" 45.4m x 1.88m x 1.91m	12,300 lbs 5 580 kg
Counterjib Section #1 (Inner) 	30'-8" x 6'-4" x 5'-5" 9.35m x 1.93m x 1.66m	6,000 lbs 2 720 kg	Jib Assembly Part 2 ⁷ 200-ft (60.9m) ③④⑤⑥⑧	123'-9" x 6'-4" x 7'-1" 37.7m x 1.88m x 1.85m	10,900 lbs 4 945 kg
Counterjib Section #2 ⁴ (Outer) 	38'-7" x 9'-1" x 5'-11" 11.75m x 2.77m x 1.8m	14,220 lbs 6 450 kg	Jib Assembly Part 2 ⁷ 180-ft (55.0m) ③④⑤⑧	104'-9" x 6'-4" x 7'-1" 31.9m x 1.88m x 1.85m	9,700 lbs 4 400 kg
Hoist Unit ⁵ (105 hp/78 kW) 	9'-2" x 8'-11" x 4'-7" 2.79m x 2.72m x 1.4m	10,220 lbs 4 635 kg	Jib Assembly Part 2 ⁷ 162-ft (49.2m) ③④⑧	85'-9" x 6'-4" x 7'-1" 26.1m x 1.88m x 1.85m	7,300 lbs 3 310 kg
Counterweight Block A 	14'-8" x 7'-5" x 5'-1" 4.47m x 0.19m x 1.55m	6,800 lbs 3 085 kg	Jib Assembly Part 2 ⁷ 143-ft (43.4m) ③⑤⑧	66'-8" x 6'-4" x 7'-1" 20.3m x 1.88m x 1.85m	5,900 lbs 2 675 kg
Counterweight Block B 	9'-5" x 5'-5" x 5'-1" 2.87m x 0.14m x 1.55m	3,200 lbs 1 450 kg	Jib Assembly Part 2 ⁷ 124-ft (37.6m) ③⑧	47'-8" x 6'-4" x 7'-1" 14.5m x 1.88m x 1.85m	4,300 lbs 1 950 kg
2-Part Trolley (Outer) 	5'-7" x 7'-1" x 4'-2" 1.7m x 2.16m x 1.28m	850 lbs 385 kg	Top Climbing Unit with Hydraulics (S35) 	29'-3" x 11'-6" x 11'-6" 8.9m x 3.5m x 3.5m	24,750 lbs 11 230 kg
Hook Block 	2'-5" x 1'-1" x 5'-7" 0.74m x 0.33m x 1.69m	900 lbs 410 kg	Jib A-frame 	21'-7" x 5'-5" x 4'-8" 6.57m x 0.14m x 1.43m	800 lbs 360 kg

NOTE: Weights and dimensions are approximate. Scale components before lifting.

¹ Turntable Upper Part includes swing motors and slewing ring. Does not include slewing ring support and support frame.

² Turntable Lower Part includes slewing ring support and support frame. Does not include Upper Part, slewing ring and swing motors.

³ Includes Counterjib Sections #1 and #2, 105 hp (78 kW) AC hoist unit with frame, electrical panels and handrails. Does not include wire rope.

⁴ Counterjib Section #2 includes 105 hp (78 kW) AC hoist unit with frame, electrical panels and handrails. Does not include wire rope.

⁵ Includes frame and electrical panels. Does not include wire rope.

⁶ Jib Assembly Part 1 includes jib sections, pendant cables, jib A-frame, trolley drive unit, trolley wire rope, 2-part trolley (outer) and hook block. If 4-part application is used, weight increases by 1,750 lbs (795 kg) for additional trolley (inner) and hook block.

⁷ Jib Assembly Part 2 includes jib sections and pendant cables.

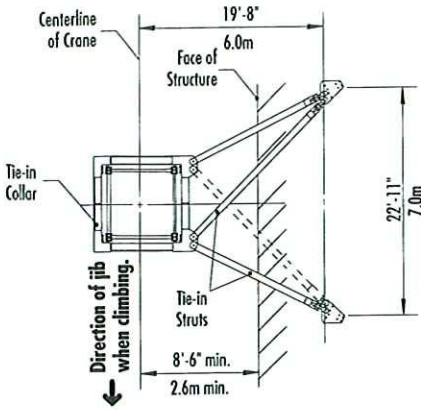

TIE-IN ASSEMBLY
(Plan View)



NOTE! If hook height exceeds 330 ft (100m), the number of tower sections above the uppermost tie-in location MUST be reduced by 1 tower section.

* Lower the top climbing unit to the uppermost tie-in prior to operating crane at maximum hook height.

Consult Morrow Equipment for specific information regarding dimensions, tie-in locations, reaction forces and slab openings.

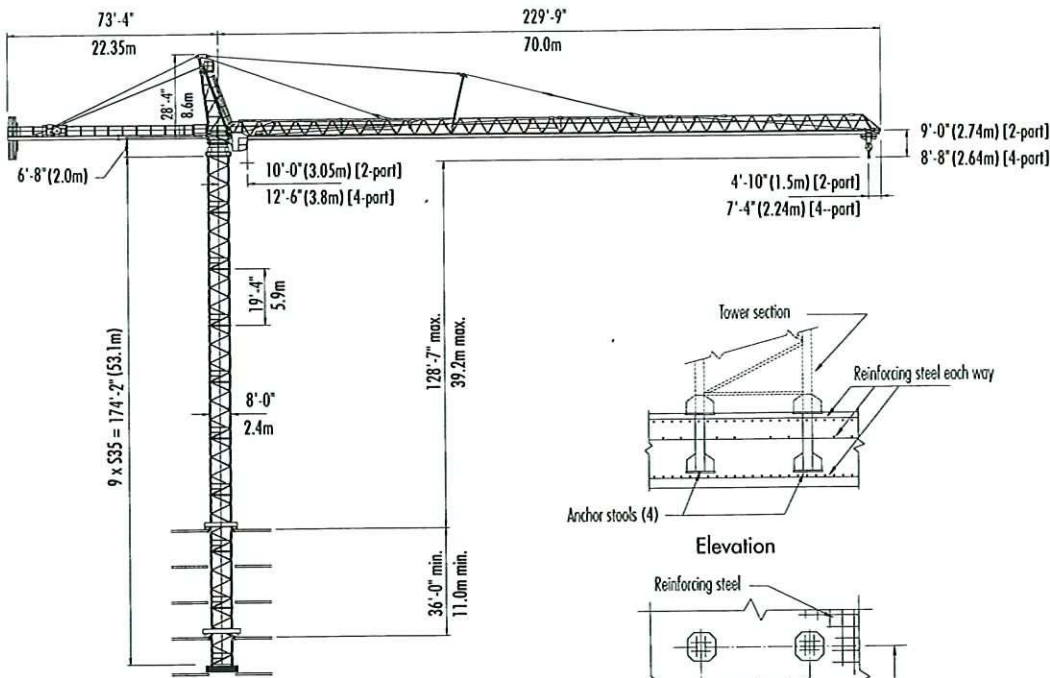

BOTTOM CLIMBING
with S35 Tower Sections
(Inside Structure)

FOUNDATION DETAILS
(Concrete Slab)

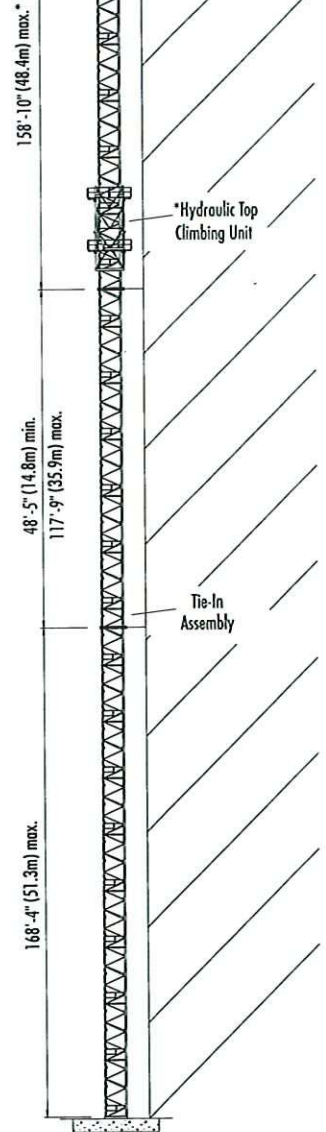

TOP CLIMBING
with S35 Tower Sections
(Tied to Structure)

Radius and Capacities

Pecco Tower Crane Model SK 280-16

4-Part Line

Hook Radius	4-Part Line		ft	60	70	80	90	100	110	121	130	140	150	159	170	178	190	197	210	223	
	Max Capacity	Radius																			
223 ft 68.0m	35,200 lbs – 46 ft 16 000 kg – 14.0m	lbs kg	18.3	21.3	24.4	27.4	30.5	33.5	36.9	39.6	42.7	45.7	48.5	51.8	54.3	57.9	60.0	64.0	68.0		
197 ft 60.0m	35,200 lbs – 56 ft 16 000 kg – 17.1m	lbs kg	18.3	21.3	24.4	27.4	30.5	33.5	36.9	39.6	42.7	45.7	48.5	51.8	54.3	57.9	60.0	64.0	68.0		
178 ft 54.3m	35,200 lbs – 59 ft 16 000 kg – 18.0m	lbs kg	18.3	21.3	24.4	27.4	30.5	33.5	36.9	39.6	42.7	45.7	48.5	51.8	54.3	57.9	60.0	64.0	68.0		
159 ft 48.5m	35,200 lbs – 62 ft 16 000 kg – 18.9m	lbs kg	18.3	21.3	24.4	27.4	30.5	33.5	36.9	39.6	42.7	45.7	48.5	51.8	54.3	57.9	60.0	64.0	68.0		
140 ft 42.7m	35,200 lbs – 63 ft 16 000 kg – 19.2m	lbs kg	18.3	21.3	24.4	27.4	30.5	33.5	36.9	39.6	42.7	45.7	48.5	51.8	54.3	57.9	60.0	64.0	68.0		
121 ft 36.9m	35,200 lbs – 64 ft 16 000 kg – 19.5m	lbs kg	18.3	21.3	24.4	27.4	30.5	33.5	36.9	39.6	42.7	45.7	48.5	51.8	54.3	57.9	60.0	64.0	68.0		

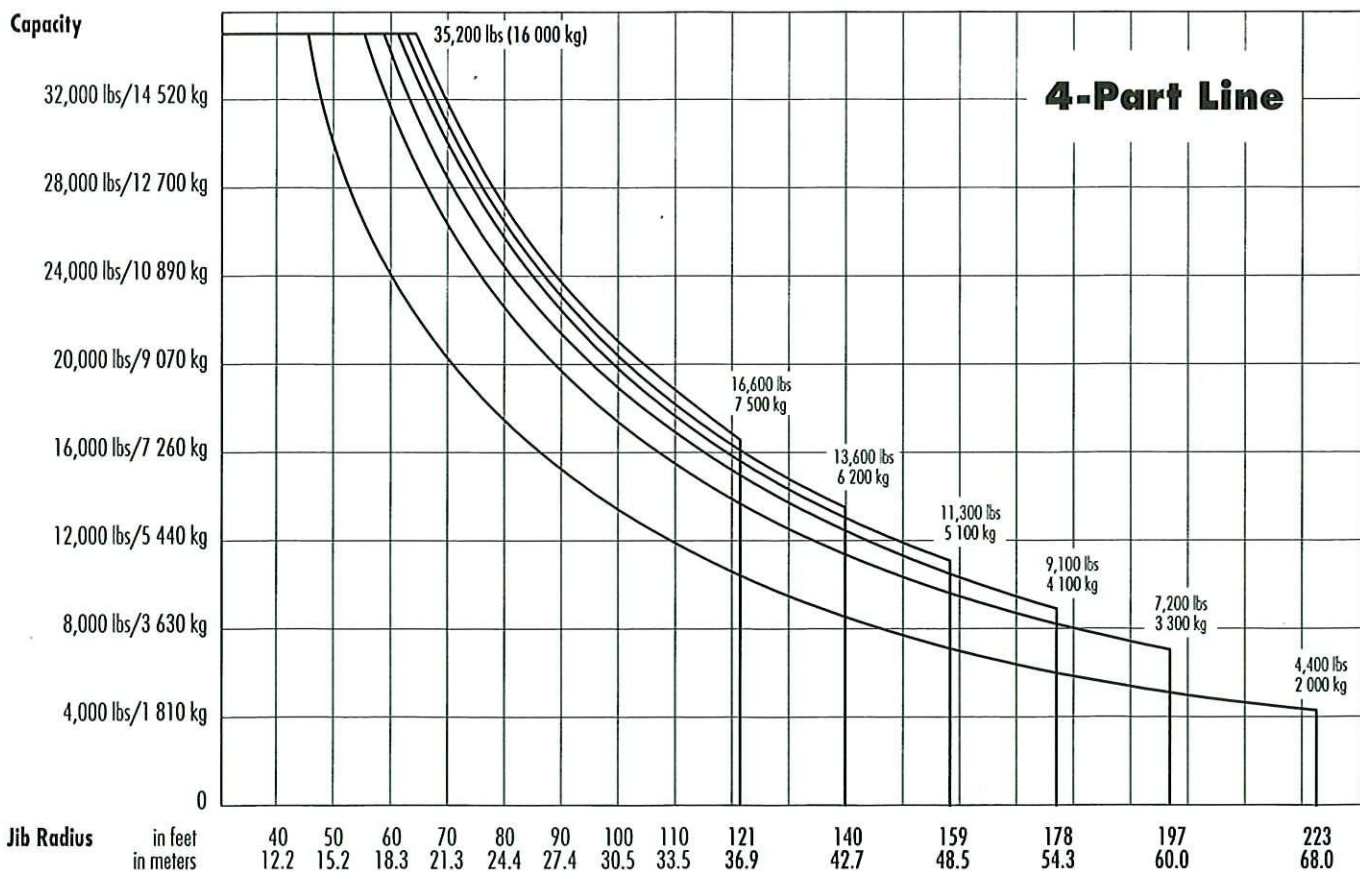

Radius and Capacities

Pecco Tower Crane Model SK 280-16

2-Part Line

Hook Radius	2-Part Line Max Capacity - Radius	ft m	88 26.8	105 32.0	109 33.2	117 35.7	121 36.9	124 37.6	130 39.6	140 42.7	143 43.4	150 45.7	162 49.2	170 51.8	180 55.0	190 57.9	200 60.9	210 64.0	225 68.6
225 ft 68.6m	17,600 lbs - 88 ft 8 000 kg - 26.8m	lbs kg	17,600 8 000	14,500 6 580	13,700 6 210	12,800 5 810	12,300 5 580	12,000 5 440	11,300 5 130	10,400 4 720	10,200 4 630	9,500 4 310	8,700 3 950	8,200 3 720	7,500 3 400	7,100 3 220	6,700 3 040	6,300 2 860	5,800 2 600
200 ft 60.9m	17,600 lbs - 109 ft 8 000 kg - 33.2m	lbs kg	17,600 8 000	17,600 8 000	17,600 8 000	16,000 7 260	15,500 7 030	15,100 6 850	14,200 6 440	13,100 5 940	12,800 5 810	12,000 5 440	11,000 4 900	10,400 4 720	9,700 4 400	9,000 4 080	8,600 3 900		
180 ft 55.0m	17,600 lbs - 117 ft 8 000 kg - 35.7m	lbs kg	17,600 8 000	17,600 8 000	17,600 8 000	17,600 8 000	16,700 7 580	16,300 7 390	15,300 6 940	14,100 6 400	13,800 6 260	13,000 5 900	12,000 5 440	11,300 5 130	10,600 4 800				
162 ft 49.2m	17,600 lbs - 121 ft 8 000 kg - 36.9m	lbs kg	17,600 8 000	17,600 8 000	17,600 8 000	17,600 8 000	17,600 8 000	17,100 7 760	16,200 7 350	14,800 6 710	14,600 6 620	13,700 6 210	12,700 5 800						
143 ft 43.4m	17,600 lbs - 124 ft 8 000 kg - 37.6m	lbs kg	17,600 8 000	17,600 8 000	17,600 8 000	17,600 8 000	17,600 8 000	17,600 8 000	16,600 7 530	15,300 6 940	15,000 6 800								
124 ft 37.6m	17,600 lbs - 124 ft 8 000 kg - 37.6m	lbs kg	17,600 8 000	17,600 8 000	17,600 8 000	17,600 8 000	17,600 8 000	17,600 8 000											

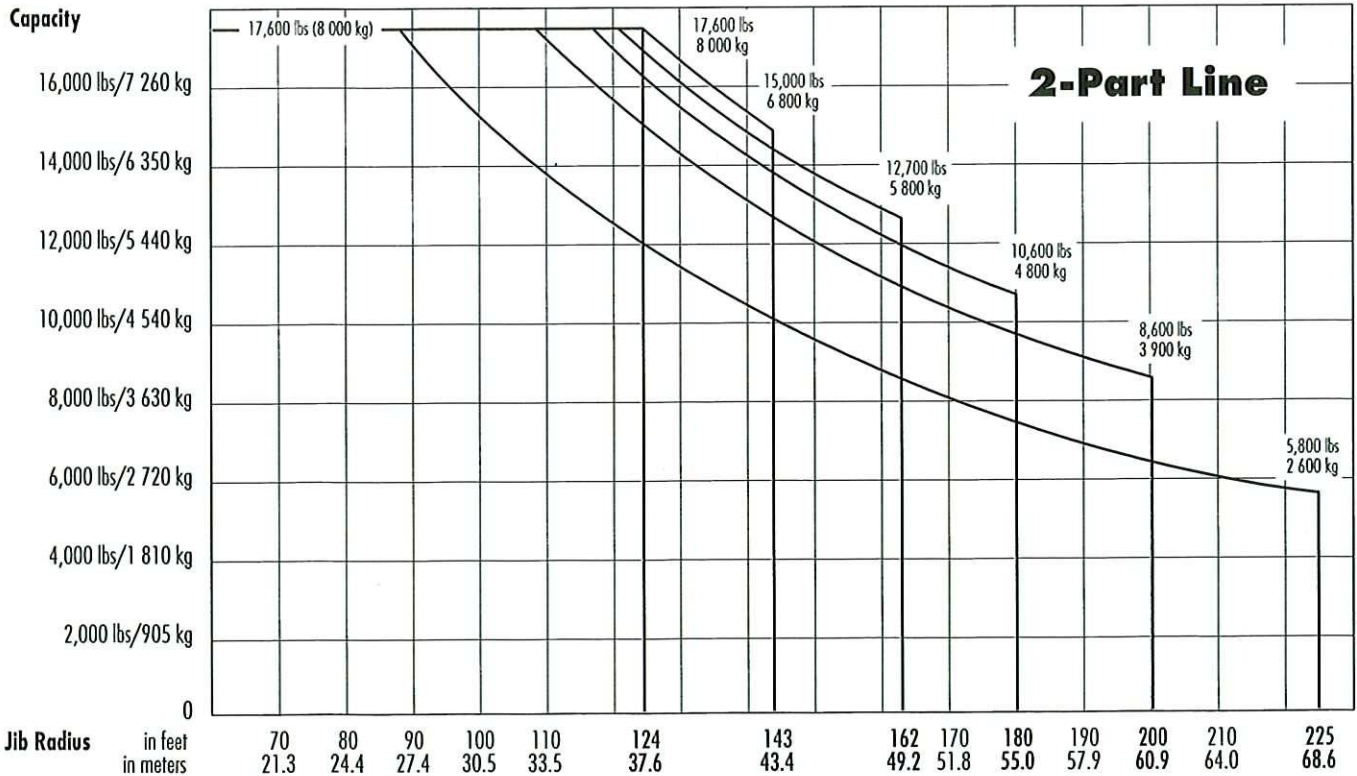

SPECIFICATIONS

Pecco Tower Crane Model SK 280-16

Hoist Speed and Capacity

Hoist Unit	2-Part Line				
	Gear	Capacity	Line Speed	Capacity	Line Speed
105 hp (78 kW) AC hoist unit 4-speed gearbox Remote-controlled gear shifting Eddy current brake 2P180 4P90	1	17,600 lbs	@ 110 fpm	8 000 kg	@ 34 m/min
	2	15,600 lbs	@ 178 fpm	7 100 kg	@ 54 m/min
	3	9,260 lbs	@ 282 fpm	4 200 kg	@ 86 m/min
	4	5,500 lbs	@ 440 fpm	2 500 kg	@ 134 m/min
	4-Part Line				
	1	35,200 lbs	@ 55 fpm	16 000 kg	@ 17 m/min
	2	31,200 lbs	@ 89 fpm	14 200 kg	@ 27 m/min
	3	18,520 lbs	@ 141 fpm	8 400 kg	@ 43 m/min
4	11,000 lbs	@ 220 fpm	5 000 kg	@ 67 m/min	

NOTE! This crane model may be equipped with a hoist unit other than that specified in the data above. To verify, check the serial number of the crane.

Motor Information

Drive Unit	Horsepower	Kilowatts	Speed	
Trolley (2-part line)	12 hp	9 kW	max. 320 fpm	max. 96 m/min
Trolley (4-part line)	12 hp	9 kW	max. 160 fpm	max. 48 m/min
Swing *	2 x 12 hp	2 x 9 kW	1.0 rpm	

* NOTE! Jibs up to and including 143-ft (43.4m) hook reach require only one swing motor; jibs with 162-ft (49.2m) hook reach and longer require two swing motors.

Power Requirements

480 Volts — 3-phase — 60-cycle	250 Amperes service with 105 hp (78 kW) AC hoist unit
--------------------------------	---

Specifications subject to change without notice. For other configurations and specifications, contact Morrow Equipment.