

PK 30002 | 33002 EH

SURFACE PROTECTION OF HIGHEST QUALITY. PERFECT APPEARANCE DURING THE ENTIRE LIFETIME.

LIFETIME EXCELLENCE



LIFETIME EXCELLENCE

PALFINGER loader cranes are convincing due to their superior life-cycle performance. They are the most economical and also the most reliable over the entire product life. From solution finding to resale.

- **Better solutions**
- **Better efficiency**
- **Better ergonomics**
- **Higher availability**
- **More reliability**
- **Better ecology**
- **Higher serviceability**
- **Higher value retention**



WIDE RANGE OF APPLICATIONS

- More efficiency with fly-jib due to DPS Plus
- Perfect appearance and extremely high value retention thanks to coating technology
- Additional applications with Power Link Plus
- More lifting power due to E-HPLS
- Increased operating times due to low-maintenance extension system





FIRST-RATE IN DESIGN AND PERFORMANCE

12 Highlights



Power Link Plus

High variety of uses

With the 15-degree reverse linkage system, you can reach through low door openings and also work inside buildings. Heavy crane work – even in difficult conditions.



Low-maintenance extension system

Reduces service time

With sliding elements made of synthetic material and the high-quality KTL coating, this boom system significantly simplifies service performed by the operator. This saves time and money – and protects the environment.



High Speed Extension

For efficient assignments

The High Speed Extension speeds up the extension boom system. Crane works faster and more efficiently.

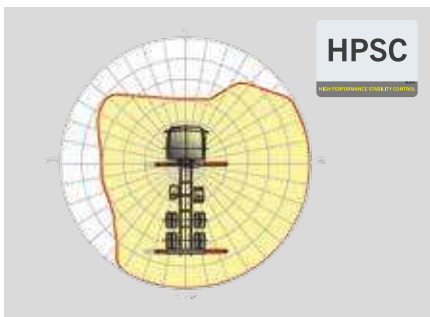

HPSC

Maximum utilisation of the working range

The variable stabiliser positioning of the High Performance Stability Control System makes it possible to utilise the lifting capacity to the maximum. It enables working within tight spaces.

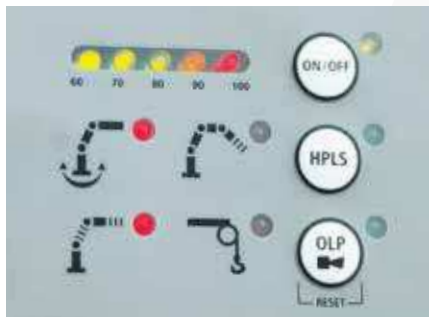

PAL 50

Comfort and safety

The PALTRONIC 50, PALFINGER offers the latest control electronics for the series production crane. The custom designed electronic operates and monitors the crane and offers more efficiency in use and safety.



Control console

All information at a glance

All important information about the crane can be seen on the main control stand. A digital indicator counts and displays the operating hours. Ergonomic control levers and the optional lighting package provide increased safety and comfort even in poor visibility conditions.



Coating technology

Top quality surface protection at a glance

The KTL coating lays the foundation for a perfect surface protection. Afterwards the components are either coated in the powder-coating facility or are finished with a two-components-topcoat. High value retention and excellent corrosion protection for the whole life of a crane.



Functional design

Practical and attractive

Robust plastic covers protect crane parts against dirt and damage. Better appearance and increased operational comfort – during the entire lifetime.



Radio remote control

Dialogue with the operator

PALFINGER radio remote controls are equipped with linear lever or cross lever and provide the greatest possible comfort for the operator. All EH models with LED-Display inform the crane operator about the different operating conditions.



Hose equipment for attachments

Versatile and user-friendly

The hose equipment offers an easy means of connecting auxiliary equipment. The hose equipment is guided in hose trays for protection.

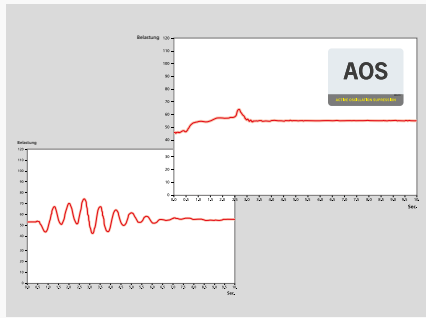

AOS

Maximum precision and safety

The active oscillation suppression system prevents „post-oscillation“ in the event of rapid braking or load changes. The stress peaks on the extension boom system are reduced and material fatigue and wear are minimised. This increases the resale value.



DPS Plus

More efficient fly-jib operation

The Dual Power System allows multiple uses of the crane both for large outreach- es as well as for heavy load operation.



* Optional features / country-specific equipment

PK 30002

HIGH PERFORMANCE

Its diligence. Your strength.

B

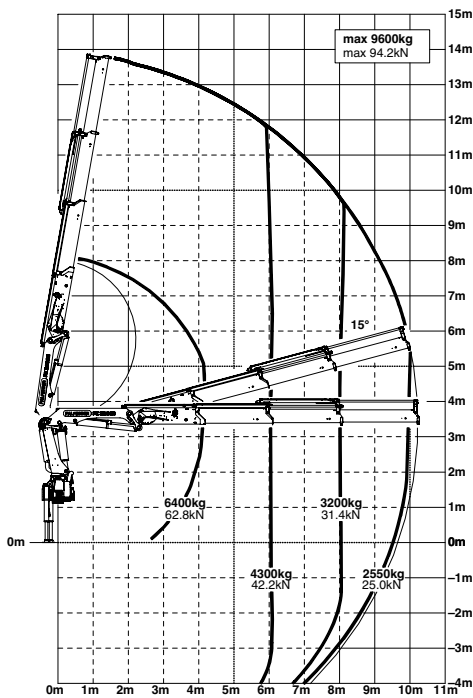

C

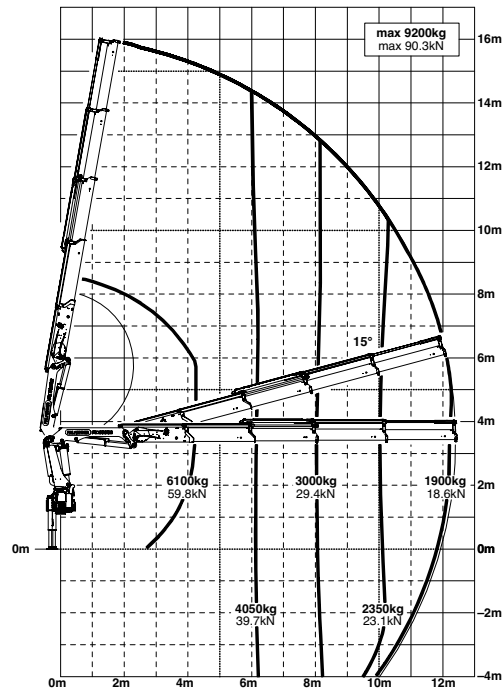

E

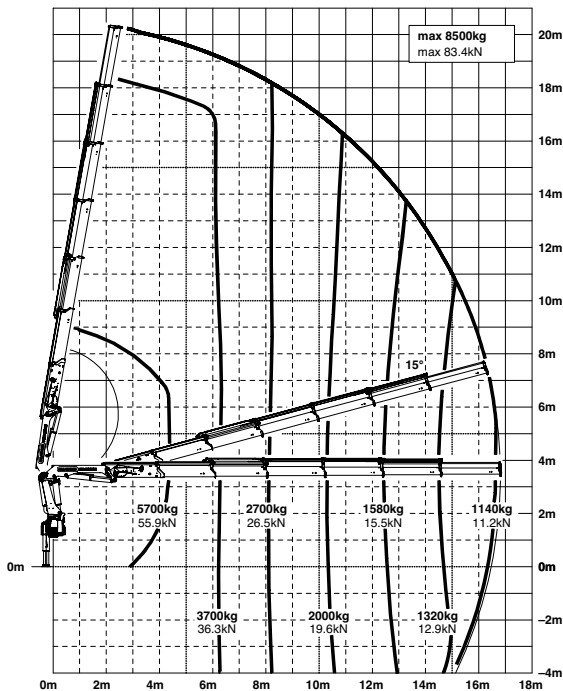

F

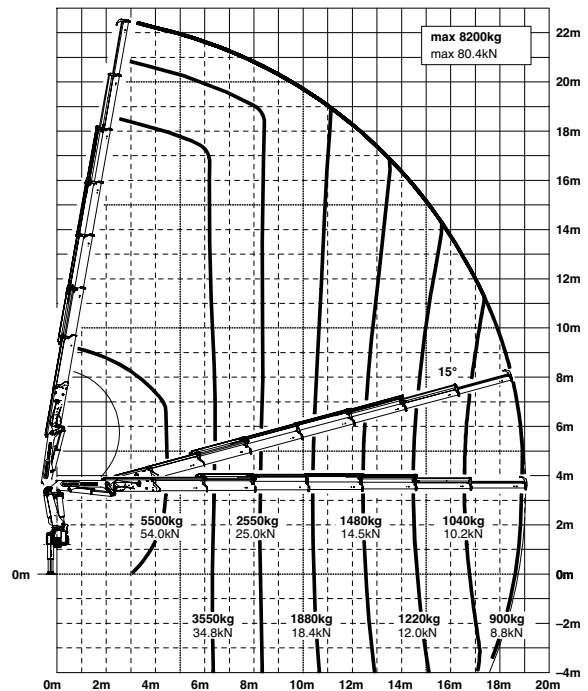

The outreaches stated are with a boom angle of 20° and are therefore not the maximum.

Lifting capacities

D

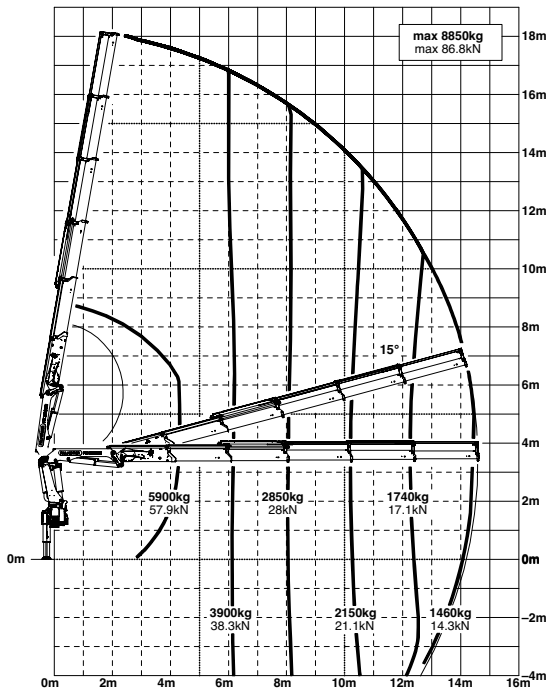

G

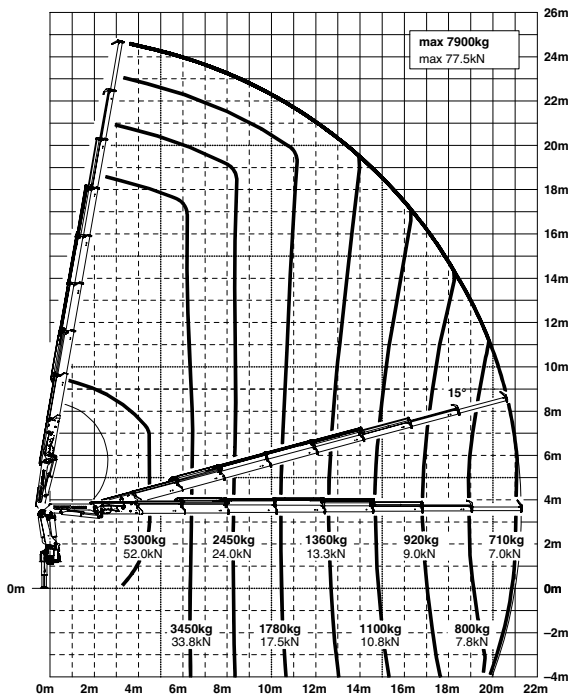

max.		10000 kg	22040 lbs	A
4.1 m	13' 5"	6700 kg	14700 lbs	
6.0 m	19' 8"	4500 kg	10000 lbs	
7.9 m	25' 11"	3450 kg	7600 lbs	

max.		9600 kg	21160 lbs	B
4.2 m	13' 9"	6400 kg	14100 lbs	
6.1 m	20' 0"	4300 kg	9500 lbs	
8.0 m	26' 3"	3200 kg	7100 lbs	
10.1 m	33' 2"	2550 kg	5600 lbs	

max.		9200 kg	20280 lbs	C
4.2 m	13' 9"	6100 kg	13500 lbs	
6.1 m	20' 0"	4050 kg	9000 lbs	
8.0 m	26' 3"	3000 kg	6600 lbs	
10.1 m	33' 2"	2350 kg	5100 lbs	
12.2 m	40' 0"	1900 kg	4200 lbs	
14.4 m*	47' 3"	1540 kg	3400 lbs	
16.6 m*	54' 6"	1260 kg	2780 lbs	

max.		8850 kg	19500 lbs	D
4.3 m	14' 1"	5900 kg	13000 lbs	
6.2 m	20' 4"	3900 kg	8500 lbs	
8.1 m	26' 7"	2850 kg	6200 lbs	
10.2 m	33' 6"	2150 kg	4750 lbs	
12.3 m	40' 4"	1740 kg	3800 lbs	
14.4 m	47' 3"	1460 kg	3250 lbs	
16.7 m*	54' 9"	1200 kg	2650 lbs	
18.8 m*	61' 8"	1000 kg	2200 lbs	

max.		8500 kg	18730 lbs	E
4.4 m	14' 5"	5700 kg	12500 lbs	
6.3 m	20' 8"	3700 kg	8200 lbs	
8.2 m	26' 11"	2700 kg	5900 lbs	
10.3 m	33' 10"	2000 kg	4400 lbs	
12.4 m	40' 8"	1580 kg	3500 lbs	
14.5 m	47' 7"	1320 kg	2900 lbs	
16.7 m	54' 9"	1140 kg	2500 lbs	
18.8 m*	61' 8"	950 kg	2100 lbs	
21.0 m*	68' 11"	810 kg	1780 lbs	

max.		8200 kg	18070 lbs	F
4.5 m	14' 9"	5500 kg	12100 lbs	
6.4 m	20' 12"	3550 kg	7900 lbs	
8.3 m	27' 3"	2550 kg	5600 lbs	
10.4 m	34' 1"	1880 kg	4150 lbs	
12.5 m	41' 0"	1480 kg	3250 lbs	
14.6 m	47' 11"	1220 kg	2700 lbs	
16.7 m	54' 9"	1040 kg	2300 lbs	
18.9 m	62' 0"	900 kg	2000 lbs	
21.1 m*	69' 3"	770 kg	1700 lbs	
23.1 m*	75' 9"	570 kg	1260 lbs	

max.		7900 kg	17400 lbs	G
4.6 m	15' 1"	5300 kg	11700 lbs	
6.5 m	21' 4"	3450 kg	7600 lbs	
8.4 m	27' 7"	2450 kg	5400 lbs	
10.5 m	34' 5"	1780 kg	3900 lbs	
12.6 m	41' 4"	1360 kg	3000 lbs	
14.7 m	48' 3"	1100 kg	2450 lbs	
16.8 m	55' 1"	920 kg	2050 lbs	
19.0 m	62' 4"	800 kg	1760 lbs	
21.1 m	69' 3"	710 kg	1560 lbs	
23.1 m*	75' 9"	570 kg	1260 lbs	

*mechanical extension

PERFECT DIMENSIONS

EXTENSION BOOM VARIATIONS

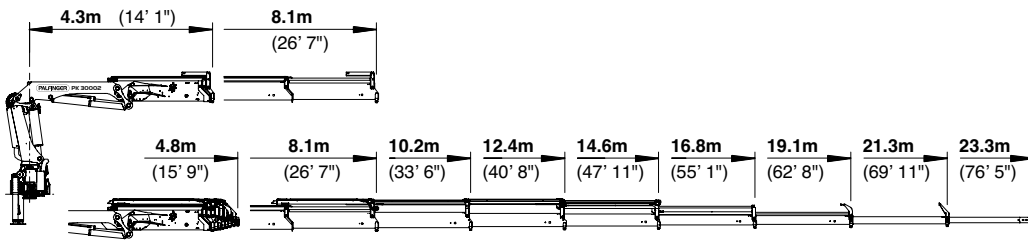

DIMENSIONS

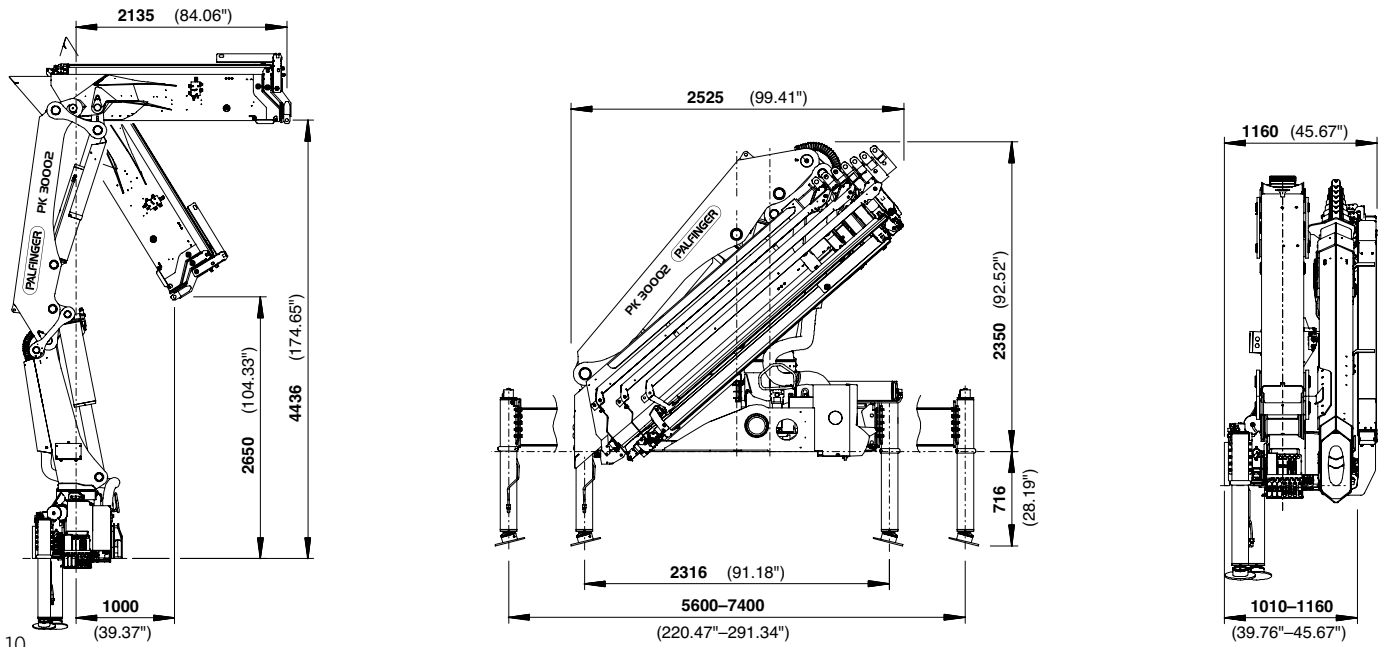

Technical specifications

EN 12999 HC1 HD4/B3

PK 30002

Max. lifting moment	28.0 mt/275.0 kNm	202810 ft.lbs
Max. lifting capacity	10000 kg/98.1 kN	22050 lbs
Max. hydraulic outreach	21.3 m	69' 11"
Max. manual outreach	23.3 m	76' 5"
Slewing angle	400°	
Slewing torque	3.2 mt/31.4 kNm	23130 ft.lbs
Stabiliser spread (std./max.)	5.6 m / 7.4 m	18' 4" / 24' 3"
Fitting space required (std.)	1.01 m	3' 4"
Width folded	2.53 m	8' 3"
Max. operating pressure	320 bar	4640 psi
Recommended pump capacity	from 55 l/min to 80 l/min	14.5 US gal./min 21.1 US gal./min
Dead weight (std.)	2876 kg	6340 lbs

PK 33002 EH

HIGH PERFORMANCE

Reliable in any situation.

C

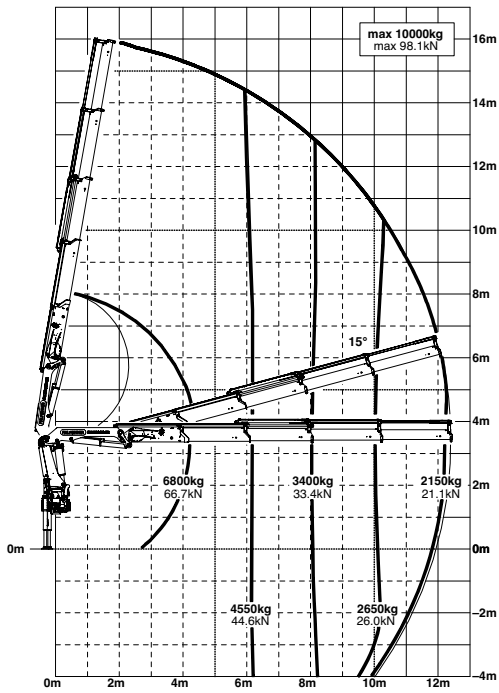

D

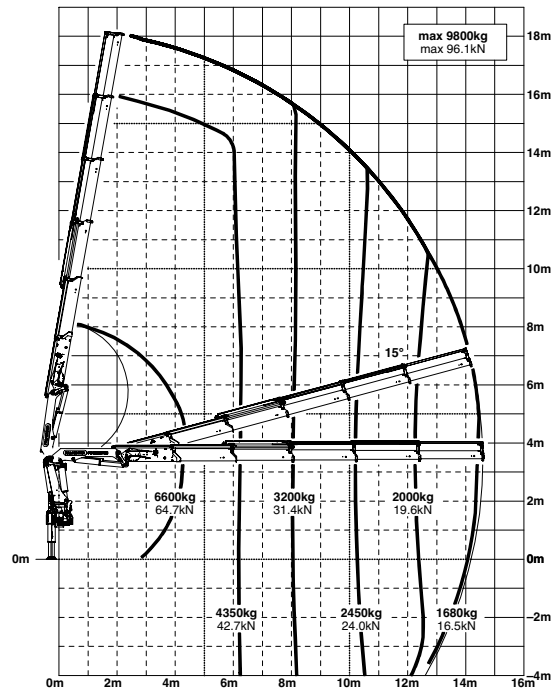

F

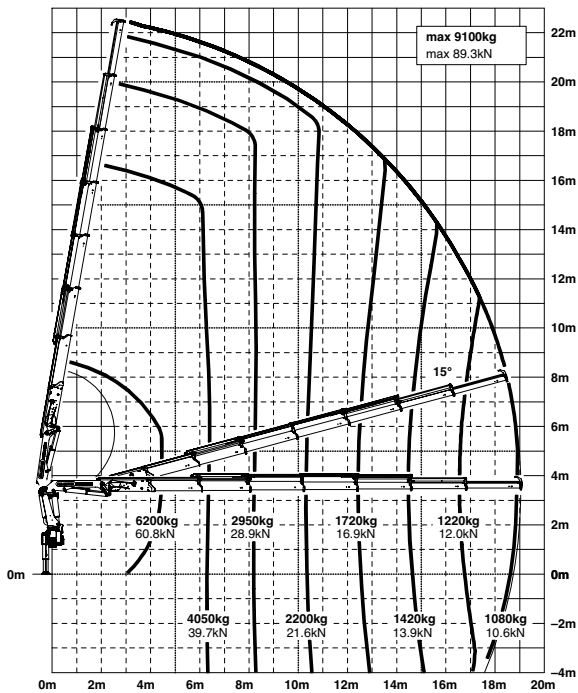

G

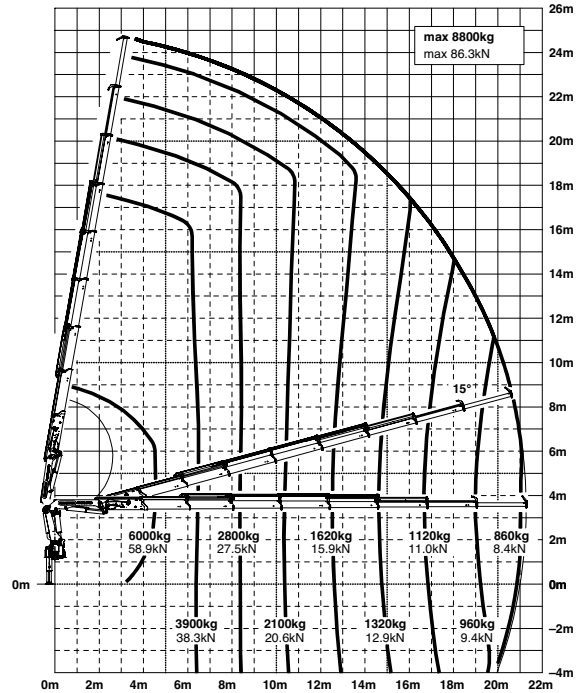

The outreaches stated are with a boom angle of 20° and are therefore not the maximum.

Lifting capacities

max.		10000 kg	22040 lbs	A
4.1 m	13' 5"	7400 kg	16300 lbs	
6.0 m	19' 8"	5000 kg	11100 lbs	
7.9 m	25' 11"	3800 kg	8400 lbs	

max.		10000 kg	22040 lbs	B
4.2 m	13' 9"	7100 kg	15700 lbs	
6.1 m	20' 0"	4800 kg	10600 lbs	
8.0 m	26' 3"	3600 kg	8000 lbs	
10.1 m	33' 2"	2850 kg	6300 lbs	

max.		10000 kg	22040 lbs	C
4.2 m	13' 9"	6800 kg	15000 lbs	
6.1 m	20' 0"	4550 kg	10100 lbs	
8.0 m	26' 3"	3400 kg	7500 lbs	
10.1 m	33' 2"	2650 kg	5800 lbs	
12.2 m	40' 0"	2150 kg	4750 lbs	
14.4 m*	47' 3"	1760 kg	3900 lbs	
16.6 m*	54' 6"	1460 kg	3200 lbs	

max.		9800 kg	21600 lbs	D
4.3 m	14' 1"	6600 kg	14500 lbs	
6.2 m	20' 4"	4350 kg	9600 lbs	
8.1 m	26' 7"	3200 kg	7100 lbs	
10.2 m	33' 6"	2450 kg	5400 lbs	
12.3 m	40' 4"	2000 kg	4400 lbs	
14.4 m	47' 3"	1680 kg	3700 lbs	
16.7 m*	54' 9"	1380 kg	3050 lbs	
18.8 m*	61' 8"	1160 kg	2600 lbs	

max.		9400 kg	20700 lbs	E
4.4 m	14' 5"	6400 kg	14000 lbs	
6.3 m	20' 8"	4200 kg	9200 lbs	
8.2 m	26' 11"	3050 kg	6700 lbs	
10.3 m	33' 10"	2300 kg	5100 lbs	
12.4 m	40' 8"	1840 kg	4050 lbs	
14.5 m	47' 7"	1540 kg	3400 lbs	
16.7 m	54' 9"	1340 kg	2950 lbs	
18.8 m*	61' 8"	1120 kg	2500 lbs	
21.0 m*	68' 11"	960 kg	2120 lbs	

max.		9100 kg	20060 lbs	F
4.5 m	14' 9"	6200 kg	13600 lbs	
6.4 m	20' 12"	4050 kg	8900 lbs	
8.3 m	27' 3"	2950 kg	6400 lbs	
10.4 m	34' 1"	2200 kg	4800 lbs	
12.5 m	41' 0"	1720 kg	3800 lbs	
14.6 m	47' 11"	1420 kg	3150 lbs	
16.7 m	54' 9"	1220 kg	2700 lbs	
18.9 m	62' 0"	1080 kg	2350 lbs	
21.1 m*	69' 3"	920 kg	2040 lbs	
23.1 m*	75' 9"	570 kg	1260 lbs	

max.		8800 kg	19400 lbs	G
4.6 m	15' 1"	6000 kg	13200 lbs	
6.5 m	21' 4"	3900 kg	8600 lbs	
8.4 m	27' 7"	2800 kg	6200 lbs	
10.5 m	34' 5"	2100 kg	4550 lbs	
12.6 m	41' 4"	1620 kg	3550 lbs	
14.7 m	48' 3"	1320 kg	2900 lbs	
16.8 m	55' 1"	1120 kg	2450 lbs	
19.0 m	62' 4"	960 kg	2150 lbs	
21.1 m	69' 3"	860 kg	1900 lbs	
23.1 m*	75' 9"	570 kg	1260 lbs	

*mechanical extension

E

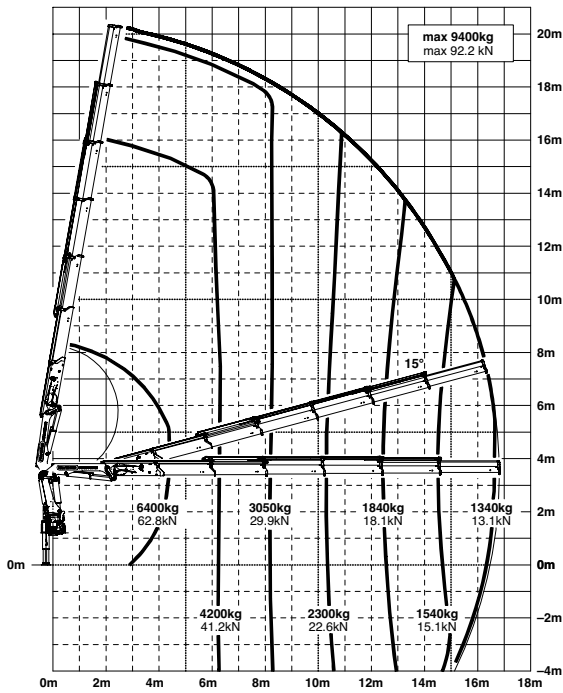

E PJ 060B JV2 DPS PLUS

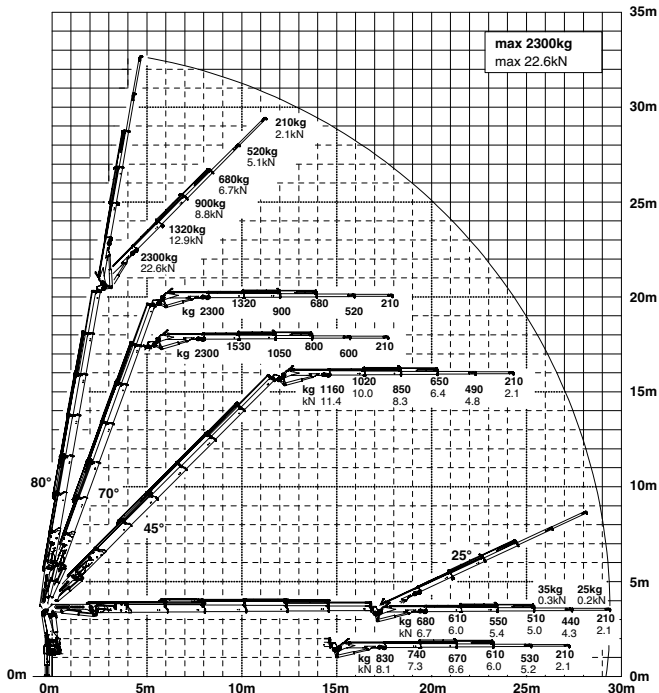

PERFECT DIMENSIONS

EXTENSION BOOM VARIATIONS

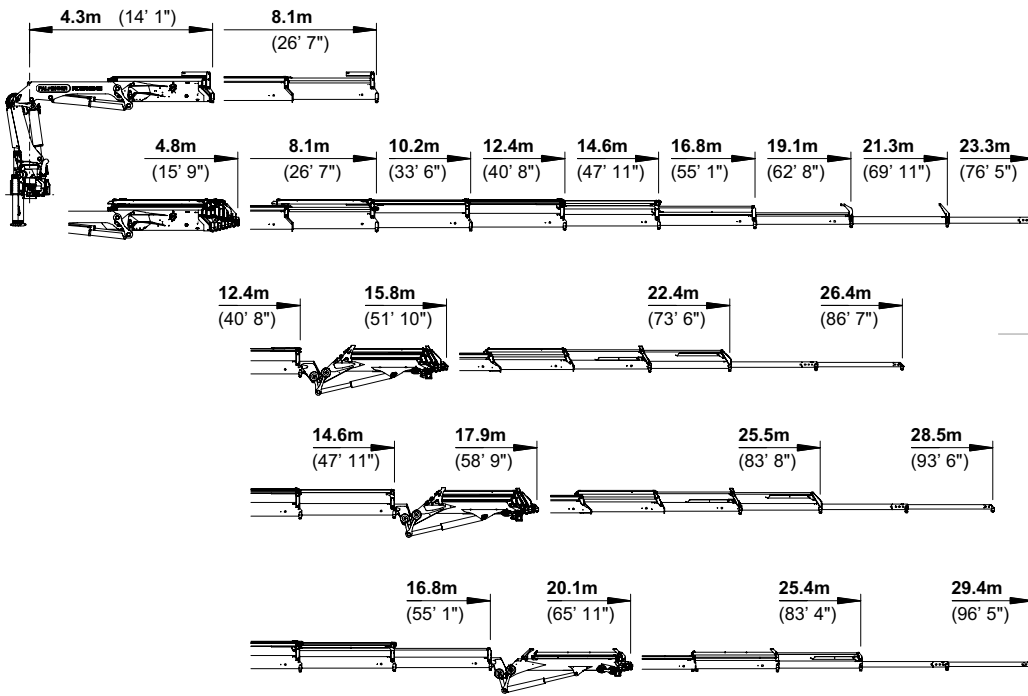

DIMENSIONS

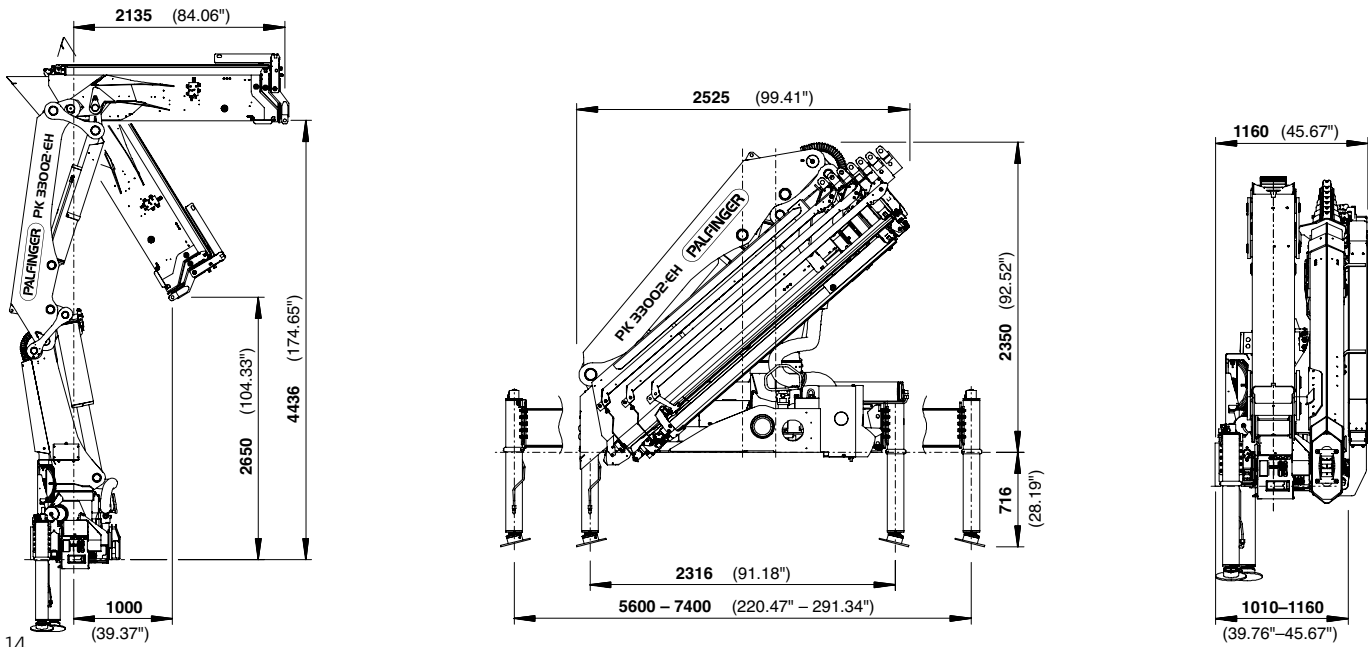

Technical specifications

EN 12999 HC1 HD4/B3

PK 33002 EH

Max. lifting moment	31.1 mt/305.0 kNm	224940 ft.lbs
Max. lifting capacity	10000 kg/98.1 kN	22050 lbs
Max. hydraulic outreach	21.3 m	69' 11"
Max. manual outreach	23.3 m	76' 5"
Max. outreach (with fly-jib)	29.4 m	96' 5"
Slewing angle	400°	

C PJ080C JV2

Slewing torque	3.2 mt/31.4 kNm	23120 ft.lbs
Stabiliser spread (std./max.)	5.6 m / 7.4 m	18' 4" / 24' 3"
Fitting space required (std.)	1.01 m	3' 4"
Width folded	2.53 m	8' 3"

D PJ080C JV2

Max. operating pressure	350 bar	5075 psi
Recommended pump capacity	from 80 l/min to 100 l/min	21.1 US gal./min 26.4 US gal./min
Dead weight (std.)	2876 kg	6340 lbs

E PJ060B JV2

Package model

- E-HPLS
- Paltronic 50
- Radio remote control with LED display
- Danfoss control valve or PVG2000
- 8.5 kW oil cooler
- 200 l oil tank



KP-H30/33002EM3+EN

Cranes shown in the leaflet are partially optional equipped and do not always correspond to the standard version. Country-specific regulations must be observed. Dimensions may vary. Subject to technical changes, errors and translation mistakes.