

National Series 200 Buyer's Guide

Truck-mounted telescoping cranes and accessories

Maximum height: 48 feet/14.6 meters

Maximum capacity: 10,700 pounds/4.9 metric tons

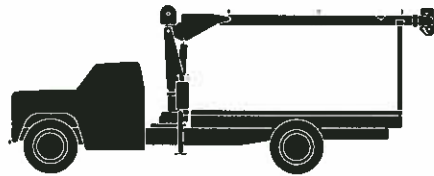

America's Truck-Mounted Hydraulic Crane Leader

National Series 200



Dear Crane User:

National Crane Corporation values your goodwill. We have developed our engineering, manufacturing, sales and service programs with you — our customer — in mind.

This Series 200 Buyer's Guide provides you with technical data and other considerations that will give you an informational base to make a sound and sensible buying decision. We encourage you to compare the technologies, capabilities and other benefits that National Crane offers against those of competitive manufacturers. We are confident that when you are equipped with all of the facts, National will be your brand of preference.

Our compact Series 200 offers a vertical reach of 48 feet, a rated capacity of 10,700 pounds, and a selection of accessories, allowing you to tailor your crane to your lifting needs.

National has been in business, manufacturing truck-mounted hydraulic telescoping and articulating cranes, for a full quarter-century. We have earned our reputation for quality through performance — through sound, sensible engineering and the manufacture of durable, user-oriented cranes that meet the most stringent on-the-job demands.

Our cranes are subjected to the industry's most demanding testing program. Each crane undergoes quality inspections at all levels of the manufacturing and assembly process. We like to think that National's emphasis on quality is a key reason our cranes have, traditionally, retained the highest market value among comparable products year after year.

We offer strong warranty protection. Moreover, when you buy a National, you receive support from our outstanding network of dealers. Working with National, they are responsive to your parts and repair requirements. National's emphasis on customer service and responsiveness is unexcelled in the industry.

For these, and other reasons, National is touted as America's truck-mounted crane leader. We hope that you will take your cue from the many demanding users who have purchased Nationals over the past 25 years. Read the information that follows carefully. I am confident that you will be impressed.

Sincerely,

Ted Urbanek
President
National Crane Corporation

Why buy a National Series 200?



National's Series 200 telescoping crane gives you the durability and performance you need and expect in a tough, compact crane. When your lifting needs require a crane in this class, the National Series 200, with its 10,700-pound (4.9MT) rated capacity and 48-foot (14.6m) vertical reach, is your best buy for many reasons:

Field-proven Durability

- National has manufactured cranes since 1963 (more than a quarter century).
- More than 17,000 field-proven cranes verify National's manufacturing expertise.
- Nearly 90% of all National cranes ever manufactured are working on the job today.

Attention to Quality

- National's industry-leading testing program subjects all prototype models to state-of-the-art strain gauge and life cycle testing to verify structural integrity.
- Each Series 200 undergoes numerous quality inspections at all levels of manufacture and assembly. All operating functions are tested prior to shipment.
- Random audits of cranes are conducted by National's



president and other top company officials to verify that high quality standards are maintained.

- All structural welders at National must pass AWS certifications.
- Component manufacturers are subjected to critical review by National's senior management before they can qualify as a supplier of National Crane parts.
- Inspections of incoming material and components ensure that purchased items will perform as expected.
- Material certifications are maintained and steel composition is regularly verified.
- All tooling and instruments are calibrated and verified to ensure parts consistency.

Retained Market Value

- National cranes traditionally retain higher resale value year after year.

Responsive Service

- Each Series 200 is backed by strong after-sale and service support. National's professional, factory-trained dealer network spans the nation.
- Authorized National dealers maintain a parts stocking program for your Series 200.
- When a dealer cannot immediately supply a part, the factory's back-up program provides 24-hour parts shipping in 90% of all breakdown rush orders.

Strong Warranty Protection

- The Series 200 is backed by a solid warranty covering defects in materials and workmanship for six months from the date of shipment.
- And more...**

National Series 200

Testing Program

National Crane established its original product durability standards by carefully evaluating the performance of competitive machines. Taking the best performances from these tests, National engineers set their own standards **more than 50% higher!** This is the same testing standard each National must pass today.

Before a new model is released for production manufacturing it is subjected to state-of-the-art testing. For example, a plastic-based "brittle lacquer" coating is applied to the crane. After loading, test engineers inspect the coating for cracks. The special lacquer has virtually no elastic qualities, so stretching or deformation of the metal shows up in "fractures" of the coating, perpendicular to the direction of stretching.

This procedure indicates where engineers are to place strain gauges, tiny chips printed with electronic circuitry which expand or contract with changes in the metal. Minute changes in electrical resistance are measured by a computerized strain gauge monitor and printed out for engineering studies. Strain gauges measure metal deformation as small as one-millionth of an inch.

After strain gauge testing, the prototype of each new model undergoes life-cycle testing. The crane is operated at full-load through a full life-cycle under close scrutiny. Outriggers, frames, and other components are loaded and rotated through a complete range of motion for the prescribed number of cycles.

All components used on National cranes are subject to a multi-level inspection program during manufacture and assembly. National's attention to testing ensures that each crane delivered to the field is ready for on-the-job action.

Strong, Four-Plate Booms.

National fabricates telescoping boom sections from four high-strength steel members welded with perpendicular corners. This box-section construction allows the use of thicker top and bottom plates for extra strength. The use of thinner side plates means increased capacity through lower boom weight. Only strong, low alloy steel is used in National booms. It is welded with automatic, low-hydrogen techniques for extra strong seams. Corner seams are ultrasonically tested for proper penetration.

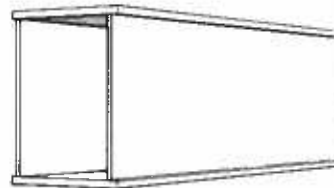

Smooth Extension.

National booms telescope smoothly and easily, even under full load, gliding on extra-smooth, self-lubricating nylon bearing plates.

Worm Gear Winch.

The Series 200 is equipped with a Tulsa Model 9 worm gear winch with an automatic friction brake and hydraulic motor control valve brake. The winch is filled with $\frac{7}{16}$ " diameter rotation resistant cable. See the winch data chart on page eight for further information.



Dual Operator Stations.

Standard dual operator stations feature identical controls in a SAE orientation of functions (you always work the same control with the same hand). The stations are positioned at platform level to achieve load visibility and enhance efficiency. Each station is equipped with an engine stop button and a horn for signaling and warnings. The control system uses specially-designed notched metering valves for precise control of all movements. All valves are accessible for fast, easy service.

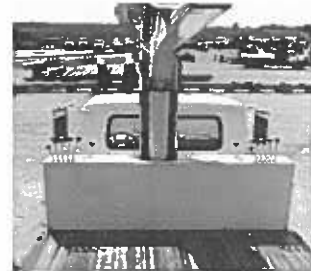

Positive Turret Rotation.

The Series 200 gives you the precision of rack and pinion rotation. The system is simple, reliable and, because it has fewer parts, easy to maintain. Service is convenient. National has reduced the bulk of the frame above the truck to lower the center of gravity.

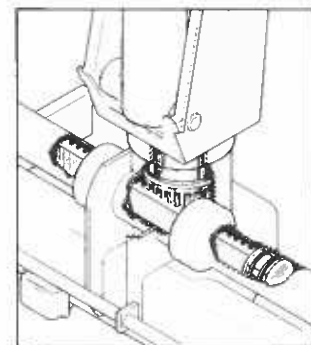

Compact Design.

The Series 200 is tough but compact. Even with the standard access area between the cab and crane, the 200 takes only 34 inches of bed space, leaving more room for payloads. The access area is a passageway, allowing limited operator movement between control stations.

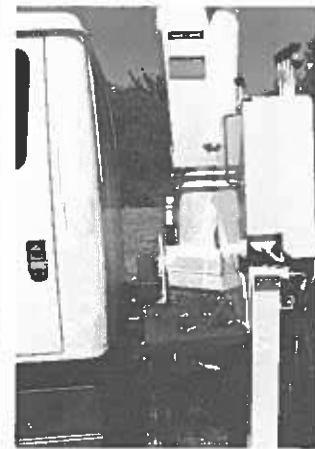

Easy Service.

The Series 200 has been engineered, from the frame up, for ease of service. The boom extend cylinder can be removed for service through the end of the boom by simply removing the winch assembly. There's no need for the complex and time-consuming pulling of the second section. All control valves have been located for easy service. They are accessible by simply removing the control console cover. The oil reservoir has been separated from the crane frame for easy attachment and access on the truck frame. All of this means your Series 200 crane will spend less time in maintenance, more time on the job.

Mounting Versatility.

The Series 200 mounts on standard, single-rear-axle trucks with a choice of two standard mounting configurations (see page nine for details).

Wide, All-Hydraulic Outriggers.

Series 200 outriggers are fully hydraulic for fast, easy set-up. They extend 12 ft. 1 $\frac{3}{4}$ in. (3.7m) horizontally and 25 $\frac{1}{2}$ in. (65cm) vertically. The wide span and extra-large outrigger pads help provide solid stability and efficient leveling, even on soft or uneven ground.

Standard automatic check valves prevent outrigger settling. Cylinders lock automatically when stowed and will not leak down in transit.

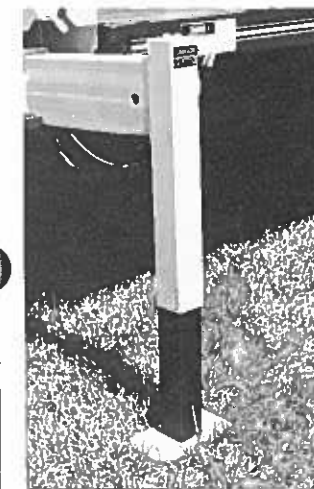

Anti-Two-Block.

The Series 200 is equipped with a standard anti-two-block system. Two blocking occurs when the winch cable and attachments contact the underside of the boom sheave case, whether by winching up or extending the boom without paying out the winch cable. When this happens, the cable can be damaged by crimping or over-tensioning. The anti-two-block system prevents cable damage by sensing the position of the winch cable end attachments with respect to the sheave case and shutting down the functions that can cause two-blocking.

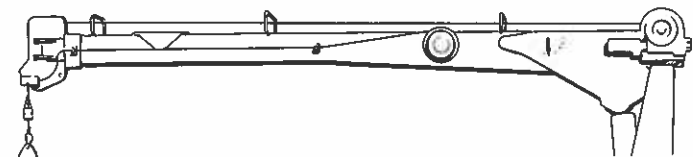

Caution

Do not operate crane booms, jib extensions, any accessories, or loads within 10 feet (3m) of live power lines. Jib and boom capacities shown are maximum for each section. Do not exceed capacities at reduced radii.

Warranty, Parts and Service

The National Warranty

National's warranty covers your crane against defects in materials or workmanship for **six full months** from the date of shipment, subject to the conditions of the warranty.

When you select a National crane, you're getting more than just a crane. You're getting a nationwide dealer warranty service network, strong warranty protection and our special concern for every product we make.

Read our warranty. Then, don't settle for less. For complete information, write National Warranty Service, Waverly, NE 68462.

The National Parts System

Authorized National Crane dealers maintain a parts supply to support the National cranes in each dealer's area. If a dealer cannot immediately supply a needed part, the factory maintains a back-up parts supply that provides 24-hour parts shipping in 90% of all breakdown rush orders. National's responsiveness to dealer requests means that your crane will be back on the job fast. National maintains a highly trained Service and Parts staff to answer dealer service questions and expedite parts shipping.

The National Service Center

National maintains a well-equipped service center where we do all our factory crane mounting. The central location of our Service Center makes it easy to return cranes for special modifications or extreme repairs. Most National dealers can perform all but the most unusual modifications or most serious repairs.

Should you need to return your crane to us for modification, warranty repair or other service, we will give it priority care and see it's returned as soon as possible.

National Series 200 Booms and Jibs

The Series 200 offers a vertical reach up to 48 feet (14.6m) with Model 228 and the 12-foot (3.7m) side-stowing jib (the jib is available only with Model 228. The chart at the right shows the boom/jib choices available for National's 200 Series cranes.

Do not operate crane or accessories within 10 feet (3m) of live power lines.

1. Load ratings shown on this chart are maximum allowable loads with the outriggers properly extended on a firm level surface and the crane leveled and mounted on a factory-recommended truck.
2. The operator must reduce loads to allow for factors such as wind, ground conditions, operating speeds and the effect of freely suspended loads.
3. Overloading this crane may cause structural collapse or instability.
4. Weights of any accessories attached to the boom or load-line must be deducted from the load chart capacities.
5. Do not exceed jib capacity at any reduced boom length.

Boom and Jib Combinations

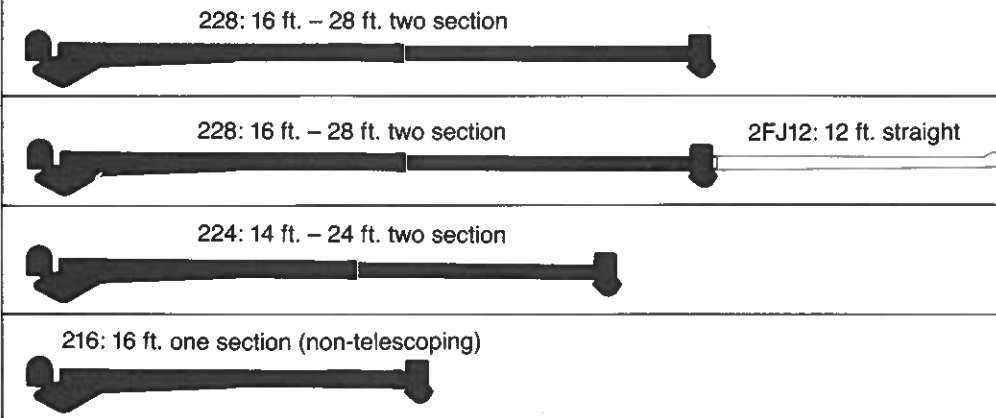

228 Capacity*		
(Metric equivalents shown in parentheses)		
Radius	All Booms Retracted	All Booms Extended
Maximum Capacity	10,700 lbs. (4,853kg)	
8' (2.4m)	6,600 lbs. (2,994kg)	
12' (3.7m)	4,750 lbs. (2,155kg)	
16' (4.9m)	3,350 lbs. (1,520kg)	3,200 lbs. (1,452kg)
20' (6.1m)		2,700 lbs. (1,225kg)
24' (7.3m)		2,300 lbs. (1,043kg)
28' (8.5m)		1,700 lbs. (771kg)

*Capacities shown are for the 228 with the load suspended, radius shown includes increase due to boom deflection. Capacities vary for cranes equipped with jibs or attachments. Consult factory for specific load rating information.



Series 200 Load Rating Charts

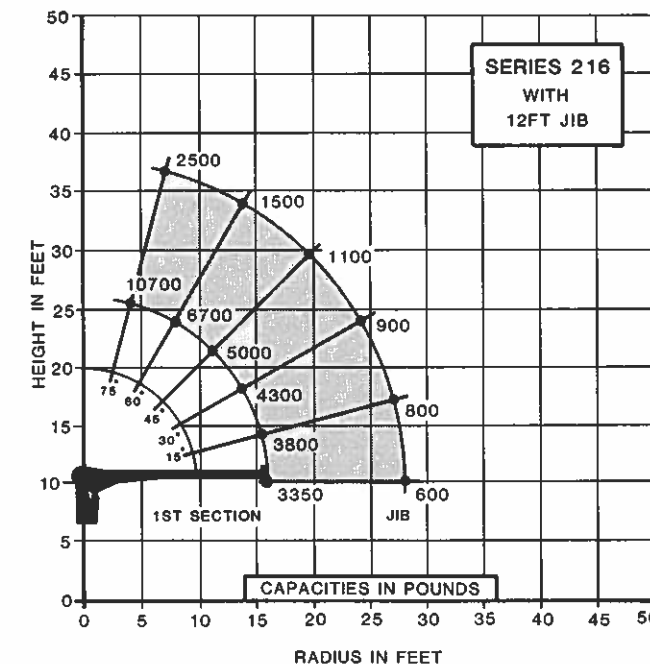
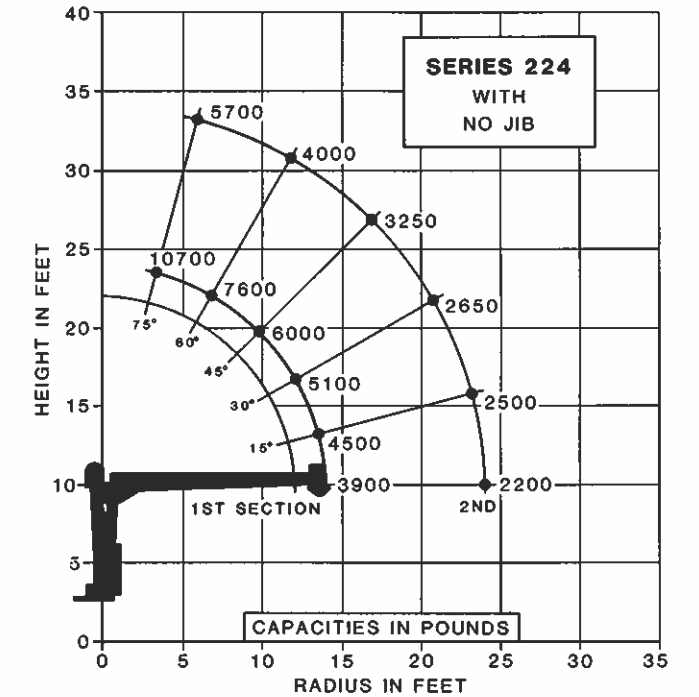
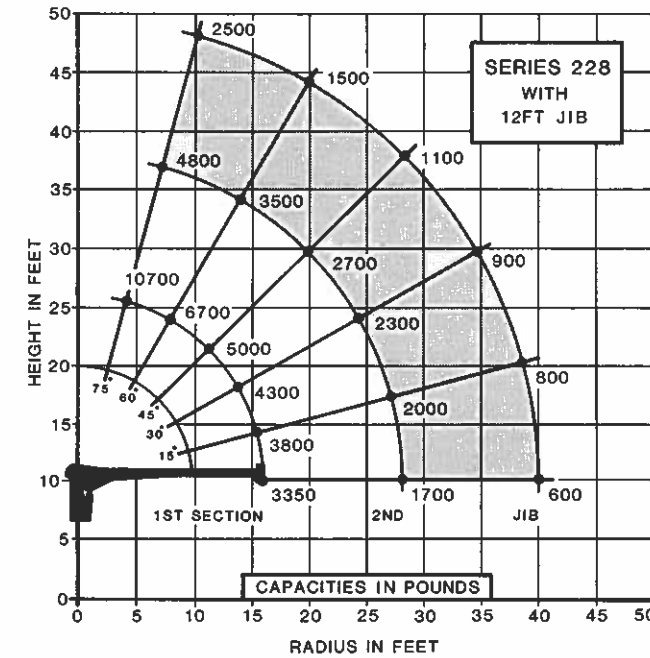

Boom Rests

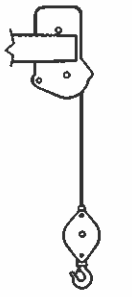
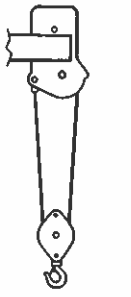
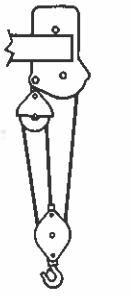
National Series 200 Winch Data			1-Part Line	2-Part Line	3-Part Line
Caution: <ul style="list-style-type: none"> Do not deadhead lineblock against boom tip when extending boom Keep at least three wraps of load line on drum at all times Use only the specified cable on this machine 					
			These are the ratings of the winch system when reeved accordingly.		
Winch	Cable Supplied	Average Breaking Strength	Lift and Speed	Lift and Speed	Lift and Speed
Tulsa Model 9	Standard 7/16" diam. 9 x 17 rotation resistant	20,500 lbs.	4,100 lbs. 85 fpm	8,200 lbs. 42 fpm	10,700 lbs. 28 fpm
	Optional 7/16" diam. general purpose 6 x 25 IWRC	17,940 lbs.	5,100 lbs. 85 fpm	10,200 lbs. 42 fpm	10,700 lbs. 28 fpm

All winch pulls and speeds are shown on the third layer. Winch pulls would increase on the first and second layers. Winch line speeds would decrease on the first and second layers. Winch pulls may be limited by the winch capacity or the cable safety factor. These are shown below:

Winch	Bare Drum Pull	Allowable Cable Pull
With standard rotation resistant rope	6,100 pounds	4,100 pounds
With optional 6 x 25 IWRC rope	6,100 pounds	5,100 pounds

*Maximum bare drum pull is 6,100 pounds with Tulsa Model 9 winch; however, because of the 5 to 1 safety factor, maximum rated pull on a single line cannot exceed 4,100 pounds on rotation resistant cable.

Cranes are tough when in use, but they can be severely damaged during travel from job to job. The only way a crane can be protected from this type of wear and damage is a strong, solid, boom rest.

- Boom Rests:**
- Add years to the life of your crane
 - Reduce stress on the crane frame
 - Protect rotation gear from transit damage
 - Remove stress from truck frame
 - Spread crane load more evenly
 - Reduce maintenance and down time

In addition, boom rests are required to provide a positive way to immobilize your crane for transit.

National Crane supplies a heavy duty horizontal rear-bed mount boom rest for the strong, sure protection of your Series 200. All Nationals must be fitted with a boom rest. All factory mounted cranes will be supplied with the boom rest shown below.

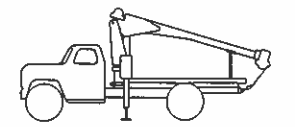

Low-profile rear bed mount for lower center of gravity

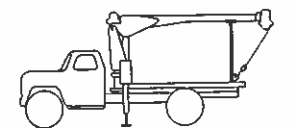

Horizontal rear bed mount for greater load space

National Series 200 Truck Specifications

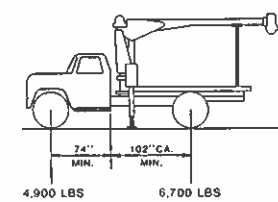
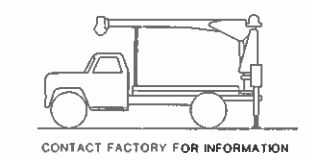
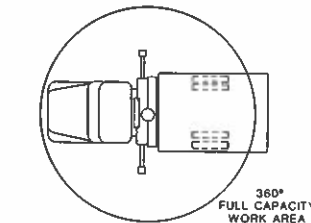
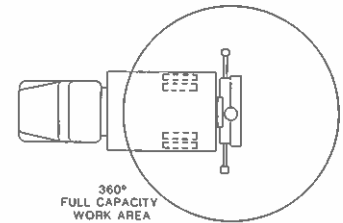
Mounting Configurations	Configuration 1	Configuration 2
	The versatility of the Series 200 can be enhanced by the mounting configurations described at the right. The configurations are based on the 228 with an 85% stability factor. The complete unit must be installed in accordance with factory requirements and a test performed to determine actual stability and counterweight requirements since individual truck chassis vary.	This is the most popular and least expensive choice for a wide variety of jobs. It requires counterweight in the underside of the bed for full capacity 360° around the truck. Care must be taken in truck selection. Consult your dealer.
Stable	360°	360°
Gross Axle Weight Rating (GAWR), Front	9,000 lbs.	Contact factory
Gross Axle Weight Rating (GAWR), Rear	15,000 lbs.	Contact factory
Wheelbase (WB)	171 inches	Contact factory
Cab to axle/trunnion (CA/CT)	102 inches	Contact factory
Frame Section Modulus (SM) under crane and through suspension 50,000 PSI	15 inch ³	Contact factory
or 110,000 PSI	12 inch ³	Contact factory
Stability Weight Front*	4,900 lbs.	Contact factory
Stability Weight Rear*	6,700 lbs.	Contact factory
Estimated Average Final Weight	16,000 lbs.	Contact factory
NOTES: <ol style="list-style-type: none"> GAWR means Gross Axle Weight Rating and is dependent on all components of the vehicle such as axles, tires, springs, frame, etc. meeting manufacturer's recommendations. Always specify GAWR when purchasing trucks. Minimum axle requirements may increase with use of longer wheelbase, service bodies or diesel engines. Tandem axle trucks must be used for hauling larger payloads. Diesel engines require variable speed governor and electric engine shut-off for smooth crane operation. 7,000 pound front axle can be used in certain applications but there are several variables that could cause axle overloads such as diesel engines, longer CA, large fuel tanks, etc. Contact factory for further information. 		 <p>CONTACT FACTORY FOR INFORMATION</p>
	 <p>360° FULL CAPACITY WORK AREA</p>	 <p>360° FULL CAPACITY WORK AREA</p>

*Estimated axle scale weights prior to installation of crane and stabilizers and subbase if required for 85% stability.

National Series 200 Accessories

Every Series 200 is more than just a crane. It's part of the most complete lifting system available.

National's accessories are designed and manufactured to the same excellent standards as our cranes. This provides you with years of low maintenance, high-productivity service.

Get the most from your National 200...make your work easier with low-cost, hardworking accessories from the National Lifting System.

Note:

Weights of all accessories attached to the boom or load-line of the crane must be deducted from the effective lifting capacity.

Consult your dealer for specific accessory availability. Some accessories cannot be used in combination with other accessories and/or certain boom/jib combinations.

Capacity Alert Systems.

National offers two capacity alert options. The audible-visual capacity alert system is designed to alert the operator when he reaches a maximum capacity condition on the crane structure. This system activates the truck horn when the capacity load is exceeded on the main boom.

The hydraulic capacity alert system is a hydraulically operated, maximum capacity sensing device that is designed to stop all of the normal crane functions that cause overload when maximum capacity is exceeded on the main boom. Neither of these systems is applicable to jib and stability capacities.

Model AAS

(Audible capacity alert system)

Model HAS

(Hydraulic capacity alert system)

Remote Control.

National offers one-hand remote control for your Series 200. Ideal for use where precise control and total load visibility are required.

Fine metering and instant response mean operators can position loads or work platforms easily.

National's remote controls are built with solid state circuitry and few working parts. They are designed for reliability. You will be impressed with the high operating speeds and modular design.

Available in two models: R4 with tilt, turn, telescope and winch functions, and R3 with tilt, turn, and telescope only. R3 should be used to control cranes from basket, using optional extension cables.

A priority control valve, operated by a trigger on the remote control unit, regulates oil flow and gives you fingertip speed control over all crane functions.

National's remote control is the lightweight, easy-to-use way to add extra versatility to your crane. Consult your dealer or the factory for availability.

Model R3

Tilt, turn and telescope.

Model R4

Tilt, turn, telescope and winch.



One Person Basket.

Strong, lightweight fiberglass basket with 300-pounds capacity puts personnel where you want them for tough maintenance and installation jobs. Optional dual basket bracket for two-basket operation on main boom. (Note: Jib will accommodate only one basket.) Easy on-off. Safety belts included. With basket(s) attached to the crane, the crane must not be operated at a position where the crane load chart shows less than the following capacities:

- One fiberglass basket — 500 pounds
- Two fiberglass baskets — 1,100 pounds

Model B1

Model B1-L

With lock

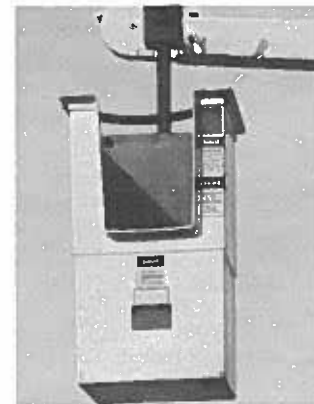

Caution

Do not operate crane booms, jib extensions, any accessories, or loads within 10 feet (3m) of live power lines. Do not exceed jib capacities at any reduced boom lengths.

Pallet Fork.

Turns your Series 200 into a versatile, payload-packing fork lift. Great for delivering palletized material right where you want it. 4,400-pound capacity with adjustable throat and teeth. Handles most loads with ease.

Capacity: 4,400 lbs. at 20" center

Throat Opening: 41" to 65" (adjustable)

Tooth Length: 38"

Tooth Width: 33.5" to 57" (outside to min. max.)

Weight: 350 lbs.

Model MKF

(Manual leveling, adjustable throat)

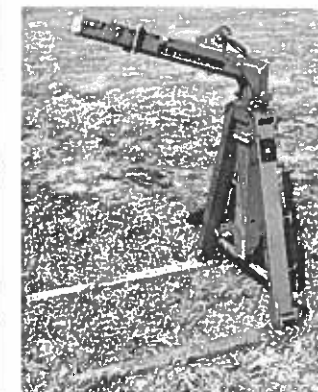

Front Stabilizer.

A single front-mounted hydraulic stabilizer is available for the Series 200. It is not designed to lift the vehicle, but will provide stability for the vehicle after it has been leveled. The SFO has a 25-inch vertical stroke and can be operated from either crane control station. The cylinder is fully enclosed for protection against dirt and on-the-job damage.

Model SFO

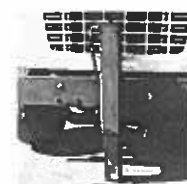

National Series 200 Specifications

General

Construction:

Low-alloy, high-tensile and other steel including T-1, Tri-Ten, Stressproof and Hi-Yield are combined with special low hydrogen welding techniques where advantageous. Standard color: Painted National Ivory.

Frame:

H.S.L.A. steel with three point mounting to minimize stress from mounting and truck frame deflection.

Rotation:

390° non-continuous, rack and pinion with 131,000 in./lb. rotation force. Extra-fine metering controls for precision swing control. All hydraulic, minimum of moving parts, excellent serviceability.

Controls:

Dual side, stand-up with operator platforms and foot accelerator. Levers identical each side for crane operation. Simultaneous operation of load line and other operations standard.

Outriggers:

All-hydraulic, horizontally-extending. Fully enclosed vertical cylinders. 12 ft. 1 3/4 in. pad center to pad center. 25 1/2 in. vertical travel. Extra large pads. Standard automatic check valves and cylinder locks.

Tilt:

Double-acting hydraulic cylinder raises and lowers boom. Butt-mounted safety holding valve prevents boom fall in event of hose failure.

Boom:

16 ft. fixed, or 2-section telescoping, 16 ft. retracted length, 28 ft. fully extended. Boxed construction. Telescopes hydraulically under rated loads on self-lubricating nylon plates. Excellent serviceability, extend cylinder can be removed without pulling second section boom.

Winch:

Worm gear with automatic friction brake and hydraulic motor control valve brake. Equipped with 125 ft. of 7/16" rotation resistant 19 x 7 wire rope with 20,500 pounds

average breaking strength or optional 7/16" general purpose 6 x 25 IWRC wire rope with 17,940 pounds average breaking strength.*

*Maximum bare drum pull is 6,100 pounds with Tulsa Model 9 winch; however, because of the ANSI safety factory requirements, the standard rotation wire rope is rated at 4,100 pounds 5:1 single line pull, and the optional 6 x 25 IWRC wire rope is rated at 5,100 pounds, 3.5:1 single line pull.

Pump:

High-pressure, high-speed, balanced-vane double pump with replaceable cartridge. Provides 9 and 25 gpm, maximum.

Filter:

In-line 10 micron cartridge.

Cylinders:

All shafts chrome-plated and stress-relieved. Polyurethane "U" cup packing and seals. All load supporting cylinders have direct-mounted load holding valves. Butt-mounted.

Valves:

Main control valves are stackable, 4-Way, 3-position with main system relief set at

2,500 PSI to protect pump. Low-effort spools with fine metering. Fittings and valves engineered for maximum serviceability. Emergency stop and horn switches on console.

Hose:

All high pressure, wire braid reinforced hose with minimum 4 to 1 safety factor.

Operating Speeds:

Rotate 390°: 37 sec. (1.8 rpm). Tilt up, -10° to +75°: 15 sec. Tilt down, +75° to -10°: 10 sec. Boom retract: 18 sec. Boom extend: 24 sec. When using remote control, function speeds will be reduced by approximately 50% for smooth operation. Speeds assume no load.

Oil Tank:

30-gallon capacity. Truck frame mounted for easy access.

Bed Space:

34 inches.

Capacity Alert Systems:

Devices available to reduce possibility of operator error. See your dealer.

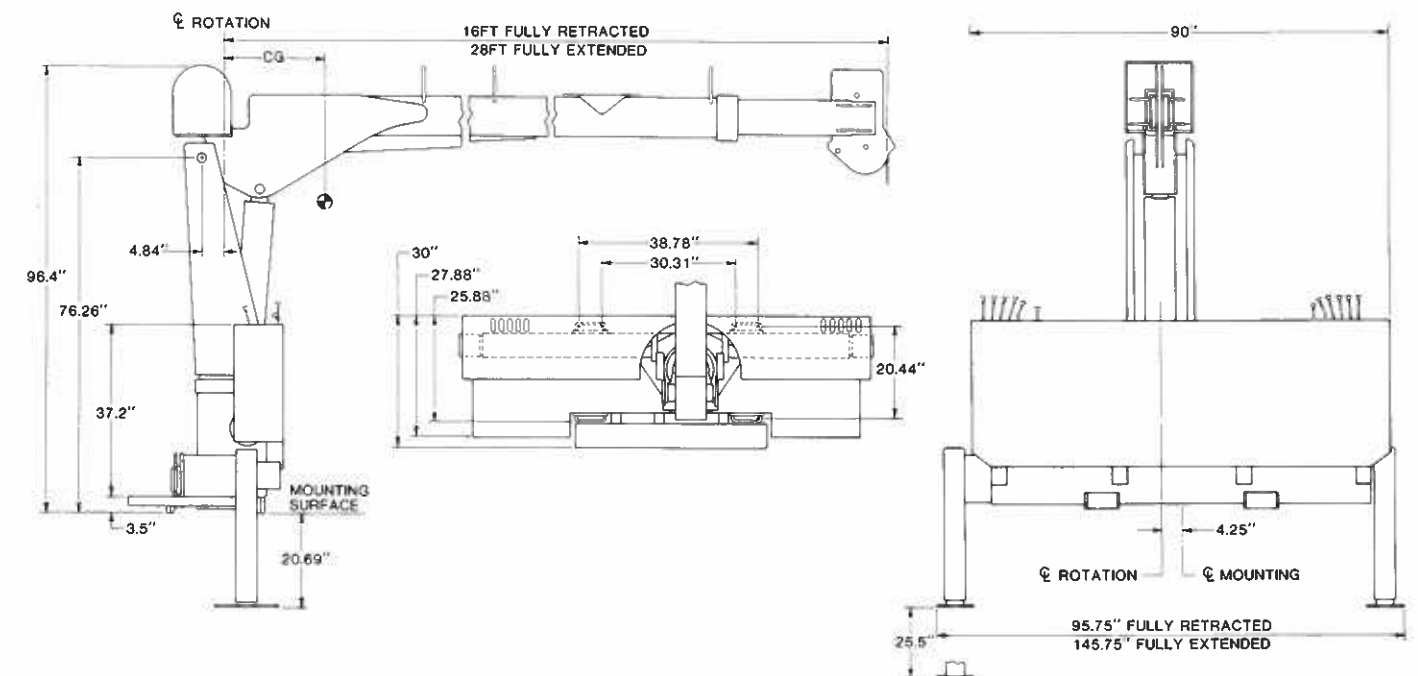

National Series 200 Proposal

<p>Date: _____</p> <p>Prepared for: _____</p> <p>_____</p> <p>_____</p> <p>Submitted by: _____</p> <p>_____</p> <p style="text-align: center;">(Firm Name)</p> <p>_____</p> <p style="text-align: center;">(Address)</p> <p>_____</p> <p style="text-align: center;">(City & State)</p> <p>_____</p> <p style="text-align: center;">(Zip)</p> <p>_____</p> <p style="text-align: center;">(Phone)</p> <p>Signed: _____</p> <p>_____</p>	<p>Description:</p> <p>1. Series _____ \$ _____</p> <p>2. Boom _____ \$ _____</p> <p>3. Jib _____ \$ _____</p> <p>4. Line Block <input type="checkbox"/> 2 Part \$ _____</p> <p>Attachments:</p> <p>5. _____ \$ _____</p> <p>6. _____ \$ _____</p> <p>7. _____ \$ _____</p> <p>Mounting:</p> <p>8. Installation <input type="checkbox"/> Std. <input type="checkbox"/> Spec. _____ \$ _____</p> <p>9. Frame reinforcing <input type="checkbox"/> Weld <input type="checkbox"/> Bolt-Extra \$ _____</p> <p>10. Platform body _____ Ft. <input type="checkbox"/> Wood <input checked="" type="checkbox"/> Steel \$ _____</p> <p>11. Weight in bed _____ lbs. (if required) \$ _____</p> <p>12. Boom rest \$ _____</p> <p>13. Chassis _____ \$ _____</p> <p>14. Rear Bumper _____ \$ _____</p> <p>15. Freight _____ \$ _____</p> <p>This quotation will remain firm for _____ Days. \$ _____</p> <p>Accepted by: _____ \$ _____</p> <p style="text-align: center;">(Name) Total Price</p> <p>_____</p> <p style="text-align: center;">(Firm Name) Date</p>
---	--



NATIONAL CRANE

General Offices
 11200 North 148th Street / Waverly, NE 68462
 Phone: (402) 786-2240 / Telex: 438061 / Fax: (402) 786-3636

Your National Dealer

National reserves the right to change designs, prices, and specifications at any time without notice.