

# Series **500E**

## **product guide**

### features

- All New Design
- 71' Three-Section Boom
- 18 Ton Rating
- Self-lubricating "Easy Glide" Wear Pads
- Internal Anti-two-block
- Auxiliary Stabilizers
- Variable Displacement Hydraulic System



### contents

Features	2
Mounting Configurations	3
Specifications	4
Capacities: With 41' Jib	5
Capacities: No Jib	6
Accessories	7

# features

## Why Buy a National Series 500E?

2



- **18 ton Rating** – The new 500E provides a 18-ton capacity.
- **New 71 ft. Three-section Boom** – The longest in its size range. The longer boom allows the operator to perform more lifts without the use of a jib, reducing setup time and improving efficiency.
- **Self-lubricating “Easy glide” Wear Pads** – The self-lubricating pads, standard on the 500E reduce the conditions that cause boom chatter and vibration. The net result is smoother crane operation.
- **Internal Anti-two-block** – The patent-pending design, standard on the 500E eliminates the external reel and wire. No more snagging reel or wire on obstructions.
- **Adjustable Swing Speed** – A control knob located on the swing motor brake release valve can be easily adjusted to the crane operator’s swing speed preference.
- **Optional New Integral Steel Torsion Bedbox** – Integral welded torsion box and flatbed. Further reduces frame flex.
- **Auxiliary Stabilizers** –
  - Independent stabilizer control
  - Bolt/Clamp on rear stabilizers
- **Quick-reeve Boom Tip and Sheave Blocks** – These standard features simplify rigging changes.
- **Pre-painted Components** – Painting crane components before assembly reduces the possibility of rust, improves serviceability and enhances the appearance of the machine.
- **Burst-of-Speed Winch** – Provides faster winch payout and pickup of unloaded cable.
- **Improved Serviceability** –
  - A removable winch allows the internal telescoping cylinder to be removed quickly, without dismantling the boom.
  - Bearings on the boom extend and retract cables can be greased through access holes in the boom side plates.
  - Internal anti-two-block wire routing eliminates damage potential.
  - The boom sheave case is open, allowing access to replace the internal anti-two-block wire and to observe internal boom components.
  - Pre-paint reduces rust.
  - Internal boom parts have been reduced, decreasing service time when rebuilding the machine.
- **New State-of-the-art Hydraulic System** – Provides smoothest operation in the market.
  - The hydraulic system features a control strategy of constant pressure, flow on demand to optimize performance. This control strategy matches the required flow to the demand (speed) of the function while the variable displacement piston pump is regulated to maintain a constant pressure to the eight section main valve. Because the pump pressure is constant, multi-function operation is very good, and precise, smooth metering is assured regardless of load.
  - Main valve spools are designed to both meter the flow and limit the maximum flow to each function. Available oil flow is optimized by using “gravity” for Boom down – no pump flow is necessary.
- **National Crane Is the Market Leader** – National is number one in the production of commercial truck-mounted boom trucks.
  - National has the boom truck industry’s leading test program. Every structural part of the crane is fully life cycle tested at full capacity. In addition to cycle testing, each model is subjected to state-of-the-art strain gauge testing that measures metal deformation as small as one-millionth of an inch. The net result is that weak areas are caught in test, not on job sites where costly downtime occurs.
  - All outrigger, lift and telescoping cylinders are manufactured to National Crane Designs, so that the seals, packing glands, and end plates are traced for accurate shipment of replacement parts.
  - National has a formalized quality program and is ISO 9001 approved.
- **National Crane Is a Quality Product That Will Provide Years of Service**
  - Parts are available for all National Crane machines, even if they are over 20 years old.

- 18-ton (15.4-t) maximum capacity
- 121 ft. (36.9 m) maximum vertical reach\*
- 81 ft. (24.7 m) maximum vertical hydraulic reach\*
- Hydraulic Capacity Alert system (HCA)
- Proportional boom extension
- High performance planetary winch
- Heavy-duty piston pump hydraulics
- \* Maximum vertical reach is ground-level to boom tip height at maximum extension and angle with outriggers/stabilizers fully extended.

500E

# mounting configurations

The configurations are based on the Series 500E with an 85% stability factor. The complete unit must be installed in accordance with factory requirements and a test performed to determine actual stability and counterweight requirements since individual truck chassis vary.

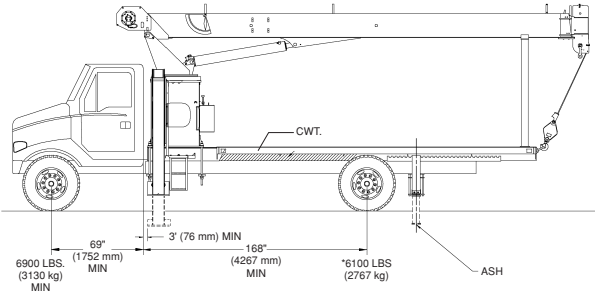

## Configuration 1 with Torsion Box – 180° Full Capacity Work Area

Working area .....	180°
Gross Axle Weight Rating Front .....	12,000 lb (5443 kg)
Gross Axle Weight Rating Rear .....	21,000 lb (9525 kg)
Gross Vehicle Weight Rating.....	33,000 lb (14,968 kg)
Wheelbase.....	237 in (602 cm)
Cab to Axle/trunnion (CA/CT).....	168 in (427 cm)
Frame Section Modulus (SM) under crane:	
110,000 PSI (758 MPa).....	15.9 in <sup>3</sup> (261 cm <sup>3</sup> )
Frame Section Modulus (SM) over rear stabilizers:	
110,000 PSI (758 MPa).....	13 in <sup>3</sup> (213 cm <sup>3</sup> )
Stability Weight, Front .....	6,900 lb (3130 kg) minimum*
Stability Weight, Rear.....	6,100 lb (2767 kg) minimum*
Estimated Average Final Weight .....	30,000 lb (13,608 kg)

This configuration is the least expensive method for the Model 571E. This mount, with the crane mounted behind the cab, requires the least weight of all mounts for stability; thus, you can haul larger payloads on your truck. It requires standard subbase and rear (ASH) stabilizers.

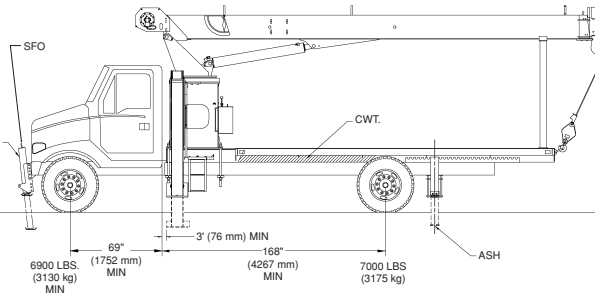

## Configuration 2 with Torsion Box – 360° Full Capacity Work Area

Working area .....	360°
Gross Axle Weight Rating Front .....	12,000 lb (5443 kg)
Gross Axle Weight Rating Rear .....	21,000 lb (9525 kg)
Gross Vehicle Weight Rating.....	33,000 lb (14,968 kg)
Wheelbase.....	237 in (602 cm)
Cab to Axle/trunnion (CA/CT).....	168 in (427 cm)
Frame Section Modulus (SM) under crane:	
110,000 PSI (758 MPa).....	15.9 in <sup>3</sup> (261 cm <sup>3</sup> )
Frame Section Modulus (SM) over rear stabilizers:	
110,000 PSI (758 MPa).....	13 in <sup>3</sup> (213 cm <sup>3</sup> )
Stability Weight, Front .....	6,900 lb (3130 kg) minimum*
Stability Weight, Rear.....	7,000 lb (3175 kg) minimum*
Estimated Average Final Weight .....	30,500 lb (13,835 kg)

Requires front SFO stabilizer to give machine full capacity 360° around the truck. Truck must meet the minimum requirements above. Front stabilizer gives the machine a solid base, helping the operator control loads precisely.

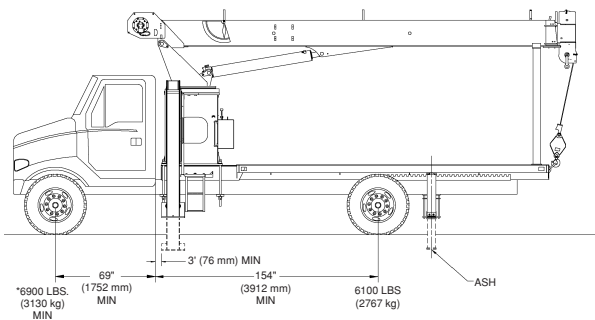

## Configuration 3 with Torsion Box – 180° Full Capacity Work Area

Working area .....	180°
Gross Axle Weight Rating Front .....	12,000 lb (5443 kg)
Gross Axle Weight Rating Rear .....	21,000 lb (9,525 kg)
Gross Vehicle Weight Rating.....	33,000 lb (14,968 kg)
Wheelbase.....	223 in (566 cm)
Cab to Axle/trunnion (CA/CT).....	154 in (391 cm)
Frame Section Modulus (SM) under crane:	
110,000 PSI (758 MPa).....	15.9 in <sup>3</sup> (261 cm <sup>3</sup> )
Frame Section Modulus (SM) over rear stabilizers:	
110,000 PSI (758 MPa).....	13 in <sup>3</sup> (213 cm <sup>3</sup> )
Stability Weight, Front .....	6,800 lb (3084 kg) minimum*
Stability Weight, Rear.....	5,500 lb (2494 kg) minimum*
Estimated Average Final Weight .....	28,750 lb (13,040 kg)

Allows the installation of the Model 560E on a chassis with a small frame by using the standard sub-base for 18' bed. In most cases, the chassis will not require reinforcing, and the amount of counterweight required is minimized, increasing payload capacities.

### Notes:

- Gross Vehicle Weight rating (GVWR) is dependent on all components of the vehicle (axles, tires, springs, frame, etc.) meeting manufacturers' recommendations: always specify GVWR when purchasing trucks
- Diesel engines require a variable speed governor and energize-to-run fuel solenoid for smooth crane operation; electronic fuel injection requires EET engine remote throttle

- All mounting data is based on a National Series 500E with an 85 percent stability factor
- The complete unit must be installed in accordance with factory requirements, and a test performed to determine actual stability and counterweight requirements per SAE J765; contact the factory for details
- Transmission neutral safety interlock switch is required with optional remote control

\*Estimated axle scale rates prior to installation of crane, stabilizers and subbase for 85% stability.

3

500E

# specifications

## Boom and Jib Combinations Data

Available in two basic models.

- 4 Model 560E** – Equipped with a 24-60 ft. (7.31-18.29 m) three-section boom. This model can be equipped with a 23-41 ft. (7.01-12.50 m) two-section jib. Maximum tip height w/41 ft. (12.50 m) jib is 110 ft. (33.53 m).  
24-60 ft. (7.31-18.29 m) three-section boom.



24-60 ft. (7.31-18.29 m) three-section boom.

**5FJ41M** 23-41 ft. (7.01-12.50 m) two-section jib



- Model 571E** – Equipped with a 27-71 ft. (8.23-21.65 m) three-section boom. This model can be equipped with a 23-41 ft. (7.01-12.50 m) two-section jib. Maximum tip height w/41 ft. (12.50 m) jib is 121 ft. (36.9 m).  
27-71 ft. (8.23-21.65 m) three-section boom.



27-71 ft. (8.23-21.65 m) three-section boom.

**5FJ41M** 23-41 ft. (7.01-12.50 m) two-section jib













**Note:** Maximum tip is measured with outriggers/stabilizers fully extended.

## 500E Winch Data

### 500E Winch Data

- All winch pulls and speeds in this chart are shown on the fourth layer
- Winch line pulls would increase on the first and second layers
- Winch line pulls may be limited by the winch capacity or the ANSI 5 to 1 cable safety factor, shown below this chart
- Hook blocks are rated at maximum capacity for the block. **Do not exceed rated cable pull with any block.**

Winch	Cable Supplied	Average Breaking Strength	1 Part Line	2 Part Line	3 Part Line	4 Part Line	5 Part Line
			Lift and Speed	Lift and Speed	Lift and Speed	Lift and Speed	Lift and Speed
Standard Planetary Winch	9/16" Diameter Rotation Resistant	38,500 lb (17,463 kg)	 7,700 lb (3 492.66 kg) 110 fpm (33.53 m/m)	 15,400 lb (6 985.32 kg) 55 fpm (16.76 m/m)	 23,100 lb (10 477.98 kg) 37 fpm (11.28 m/m)	 30,800 lb (13 970.65 kg) 28 fpm (8.54 m/m)	 36,000 lb (14 514.96 kg) 22 fpm (6.71 m/m)
Standard With "Burst-of-Speed"	9/16" Diameter Rotation Resistant	38,500 lb (17,463 kg)	 7,700 lb (3 492.66 kg) 193 fpm (58.83 m/m)	 15,400 lb (6 985.32 kg) 97 fpm (29.57 m/m)	 23,100 lb (10 477.98 kg) 64 fpm (19.51 m/m)	 30,800 lb (13 970.65 kg) 49 fpm (14.94 m/m)	 36,000 lb (14 514.96 kg) 39 fpm (11.89 m/m)

**500E**

<b>Winch</b>	<b>Bare Drum Pull</b>	<b>Allowable Cable Pull</b>
With standard rotation resistant rope .....	10,200 lb (4627 kg) .....	7,700 lb (3493 kg) .....

Block Type	Rating	Weight
Downhaul Weight.....	3.85 ton (3.49 t).....	150 lb (68 kg)
1 Sheave Block.....	11.55 ton (10.48 t).....	200 lb (91 kg)
2 Sheave Block.....	19.25 ton (17.46 t).....	355 lb (161 kg)

# capacities

## Load Rating Chart: Series 571E with 41 ft. Jib

Other Series 500E Load Rating Charts are available. National will send you a chart on request – or you may secure needed load rating information through your nearest National dealer.

5

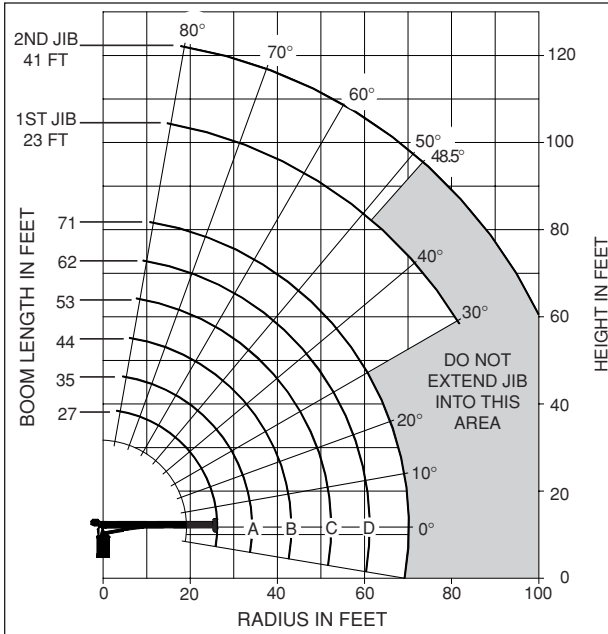

### CAUTION:

- Do not operate crane booms, jib extensions, any accessories or loads within 10 ft (3m) of live power lines or other conductors of electricity.
- Jib and boom capacities shown are maximum for each section.
- Do not exceed capacities at reduced radii
- Load ratings shown on the load rating charts are maximum allowable loads with the outriggers properly extended on a firm, level surface and the crane leveled and mounted on a factory recommended truck.
- Always level the crane with the level indicator located on the crane.
- The operator must reduce load to allow for factors such as wind, ground conditions, operating speeds and their effects on freely suspended loads.
- Overloading this crane may cause structural collapse or instability.
- Weights on any accessories attached to the boom or loadline must be deducted from the load chart capacities.
- Do not exceed jib capabilities at any reduced boom lengths.
- Do not deadhead lineblock against boom tip when extending boom or winching up.
- Keep at least three wraps of loadline on drum at all times.
- Use only specified cable with this machine.

### SERIES 571E WITH 41 FT JIB

### NOTE:

1. Operate with jib by radius when main boom is fully extended. If necessary increase boom angle to maintain loaded radius.
2. Operate with jib by boom angle when main boom is not fully extended. Do not exceed rated jib capacities at any reduced boom lengths.

### LOADLINE EQUIPMENT DEDUCT (lb.)

Downhaul weight ..... 150  
One sheave block ..... 200  
Two sheave block ..... 355

## Load Rating: Series 571E with 41 ft. Jib

### LOAD RATINGS IN POUNDS

LOAD RADIUS (FEET)	LOADED BOOM ANGLE	27 FT BOOM ANGLE	35 FT BOOM ANGLE	A	LOADED BOOM ANGLE	B	LOADED BOOM ANGLE	C	LOADED BOOM ANGLE	D	LOADED BOOM ANGLE	71 FT BOOM	LOAD RADIUS (FEET)	LOADED BOOM ANGLE	23 FT JIB	LOADED BOOM ANGLE	41 FT JIB
5	77.5°	36,000											20	79°	3,400		
8	70.5	24,050	75.5°	20,100									25	75.5	2,900	78.5°	2,050
10	66	18,900	72	16,800	76.5°	16,300	79.5°	16,050					30	72.5	2,450	76	1,800
12	61	15,650	68.5	14,400	73.5	13,950	77	13,700					35	69	2,100	73	1,550
14	56	13,650	64.5	12,600	71	12,200	75	11,950	77.5°	11,750			40	65.5	1,800	70.5	1,400
16	50.5	12,000	61	11,150	68	10,800	72.5	10,550	75.5	10,400	78°	9,350	45	62	1,600	67.5	1,200
20	37.5	9,350	53	9,000	62	8,750	68	8,550	72	8,400	75	7,750	50	58.5	1,450	65	1,050
25	14	5,700	41	7,000	55	6,950	62	6,850	67	6,700	70.5	6,500	55	54.5	1,250	62	950
30			26.5	5,200	46	5,660	55.5	5,650	62	5,550	66.5	5,450	60	50.5	1,100	59	850
35					35.5	4,500	48.5	4,700	56.5	4,650	61.5	4,550	65	46	950	56	750
40					20	3,200	40.5	3,850	50.5	3,950	57	3,850	70	41.5	850	52.5	600
45							30.5	3,100	43.5	3,300	51.5	3,300	75	36	750	48.5	500
50								14	2,000	36	2,750	46	80	30	650		
55										26	2,150	39.5					
60												32					
65												22.5					
	0	3,500	0	2,200	0	1,350	0	900	0	500							

THIS CHART IS ONLY A GUIDE AND SHOULD NOT BE USED TO OPERATE THE CRANE. The individual crane's load chart, operating instructions and other instructional plates must be read and understood prior to operating the crane.

# capacities

## Load Rating Chart: Series 571E with No Jib

6

Other Series 500E Load Rating Charts are available. National will send you a chart on request – or you may secure needed load rating information through your nearest National dealer.

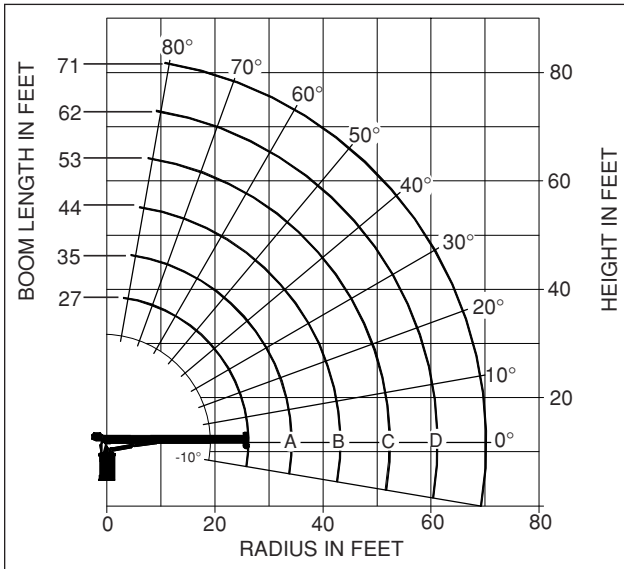

### CAUTION:

- Do not operate crane booms, jib extensions, any accessories or loads within 10 ft (3m) of live power lines or other conductors of electricity.
- Jib and boom capacities shown are maximum for each section.
- Do not exceed capacities at reduced radii
- Load ratings shown on the load rating charts are maximum allowable loads with the outriggers properly extended on a firm, level surface and the crane leveled and mounted on a factory recommended truck.
- Always level the crane with the level indicator located on the crane.
- The operator must reduce load to allow for factors such as wind, ground conditions, operating speeds and their effects on freely suspended loads.
- Overloading this crane may cause structural collapse or instability.
- Weights on any accessories attached to the boom or loadline must be deducted from the load chart capacities.
- Do not exceed jib capabilities at any reduced boom lengths.
- Do not deadhead lineblock against boom tip when extending boom or winching up.
- Keep at least three wraps of loadline on drum at all times.
- Use only specified cable with this machine.

**SERIES 571E  
WITH  
NO JIB**

### LOADLINE EQUIPMENT DEDUCT (lb.)

Downhaul weight .....	150
One sheave block .....	200
Two sheave block .....	355

## Load Rating Chart: Series 571E with No Jib

LOAD RADIUS (FEET)	LOADED BOOM ANGLE	27 FT BOOM	LOADED BOOM ANGLE	A 35 FT BOOM	LOADED BOOM ANGLE	B 44 FT BOOM	LOADED BOOM ANGLE	C 53 FT BOOM	LOADED BOOM ANGLE	D 62 FT BOOM	LOADED BOOM ANGLE	71 FT BOOM
5	77.5°	36,000										
8	70.5	24,650	75.5°	20,550								
10	66	19,500	72	17,250	76.5°	16,700	79.5°	16,350				
12	61	16,250	68.5	14,850	73.5	14,350	77	14,000				
14	56	14,250	64.5	13,050	71	12,600	75	12,250	77.5°	12,000		
16	50.5	12,600	61	11,600	68	11,200	72.5	10,850	75.5	10,650	78°	9,600
20	37.5	9,950	53	9,450	62	9,150	68	8,850	72	8,650	75	8,000
25	14	6,300	41	7,450	55	7,350	62	7,150	67	6,950	70.5	6,750
30			26.5	5,650	46	6,060	55.5	5,950	62	5,800	66.5	5,700
35					35.5	4,900	48.5	5,000	56.5	4,900	61.5	4,800
40					20	3,600	40.5	4,150	50.5	4,200	57	4,100
45							30.5	3,400	43.5	3,550	51.5	3,550
50							14	2,300	36	3,000	46	3,050
55									26	2,400	39.5	2,600
60											32	2,200
65											22.5	1,650
	0	4,100	0	2,650	0	1,750	0	1,200	0	750	0	400

THIS CHART IS ONLY A GUIDE AND SHOULD NOT BE USED TO OPERATE THE CRANE. The individual crane's load chart, operating instructions and other instructional plates must be read and understood prior to operating the crane.

**500E**

### Radio Remote Controls –

Eliminate the handling and maintenance concerns that accompany cabled remotes. Operate to a range of about 250 feet (76 m), varying with conditions.

- **Model R4R**

### One-Person Basket –

Strong but lightweight steel basket with 300-lb (139-kg) capacity, gravity hung with swing lock and full body harness.

- **Model B1-S**
- **Model 2B1-S** (for dual locking baskets)

### Heavy-duty Personnel Basket –

1,200-lb. (544-kg) capacity steel basket with safety loops for four passengers. Gravity leveling 72- x 42-inch (183- x 107-cm) platform. Fast attachment and secure locking systems. Load chart must show 2,300 lb. (1043 kg) minimum to operate this accessory.

- **Model BSA-1**
- **Model BSA-R1** (provides rotation)

### Hydraulic Oil Cooler –

Automatic, self-contained radiator system with electric fans cools oil under continuous operation.

- **Model OC**

### Continuous Rotation –

Allows rotation of turret/boom without stop.

- **Model CR**

## Dimensions Specifications

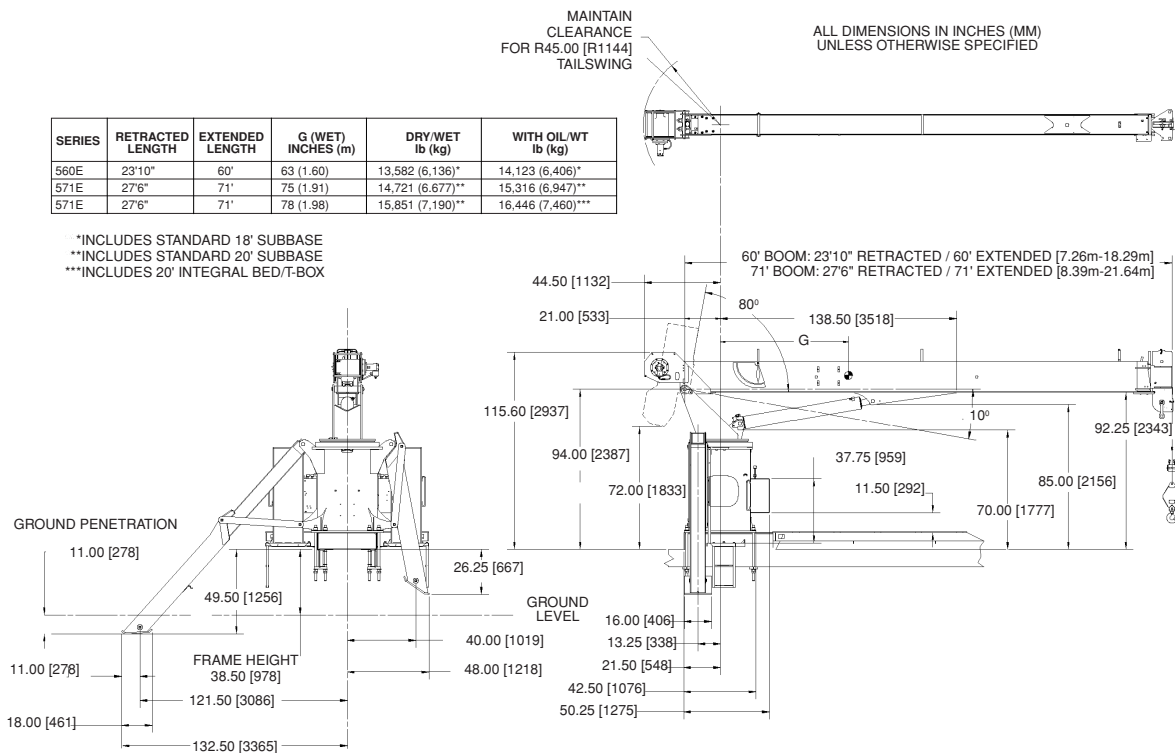

**500E**

# NATIONAL CRANE

## **Manitowoc Crane Group - Americas**

Manitowoc, Wisconsin Facility  
Tel: [Int + 001] 920 684 6621  
Fax: [Int + 001] 920 683 6277  
Shady Grove, Pennsylvania Facility  
Tel: [Int + 001] 717 597 8121  
Fax: [Int + 001] 717 597 4062

## **Manitowoc Crane Group - EMEA**

Europe Middle East & Africa  
Tel: [Int + 33] (0) 191 565 6281  
Fax: [Int + 33] (0) 4 72 18 20 20

## **Manitowoc Crane Group - UK**

Europe Middle East & Africa  
Tel: [Int + 44] (0) 191 565 6281  
Fax: [Int + 44] (0) 191 564 0442

## **Manitowoc Crane Group - Germany**

(Sales, Parts & Service)  
Tel: [Int + 49] (0) 2173 8909 0  
Fax: [Int + 49] (0) 2173 8909-30

## **Manitowoc Crane Group - France**

France & Africa (Sales, Parts & Service)  
Tel: [Int + 33] (0) 1 303 13150  
Fax: [Int + 33] (0) 1 303 86085

## **Manitowoc Crane Group - Netherlands**

(Sales, Parts & Service)  
Tel: [Int + 31] (0) 76 578 39 99  
Fax: [Int + 31] (0) 76 578 39 78

## **Manitowoc Crane Group - Italy**

Italy & Southern Europe (Sales, Parts & Service)  
Tel: [Int + 39] (0) 331 49 33 11  
Fax: [Int + 39] (0) 331 49 33 30

## **Manitowoc Crane Group - Portugal**

Portugal & Spain (Sales, Parts & Service)  
Tel: [Int + 351] (0) 22 968 08 89  
Fax: [Int + 351] (0) 22 968 08 97

## **Manitowoc Crane Group - Singapore**

Asia/Pacific excl China (Sales, Parts & Service)  
Tel: [Int + 65] 6861 1733  
Fax: [Int + 65] 6862 4040 / 4142

## **Manitowoc Crane Group - Shanghai**

China (Sales, Parts & Service)  
Tel: [Int + 86] (0) 21 64955555  
Fax: [Int + 86] (0) 2164852038

## **Manitowoc Crane Group - Beijing**

China (Sales, Parts & Service)  
Tel: [Int + 86] (0) 10 646 71690  
Fax: [Int + 86] (0) 10 646 71691

## **Manitowoc Crane Group - Middle East**

Sales  
Tel: [Int + 971] (0) 4 348 4478  
Fax: [Int + 971] (0) 4 348 4478  
(Parts & Service)  
Tel: [Int + 973] (0) 9 660 899  
Fax: [Int + 973] (0) 2 707 740

**Distributed By:**

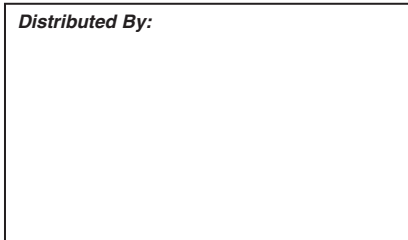

**Manitowoc**  
Crane CARE



[www.manitowoccrane.com](http://www.manitowoccrane.com)

Constant improvement and engineering progress make it necessary that we reserve the right to make specification, equipment, and price changes without notice. Illustrations shown may include optional equipment and accessories, and may not include all standard equipment.