

MULTITEL J 2 361 TA- IVECO MP 410E44H

Ente	Rev.	Descrizione	Data	Dis.	Contr.	Ap.AO
MRK	0	EMISSIONE	13-02-03	W.B.		
INGOMBRO - SCHEDA 54/1 - Rev. 0 - 15/12/00						

D32298-A

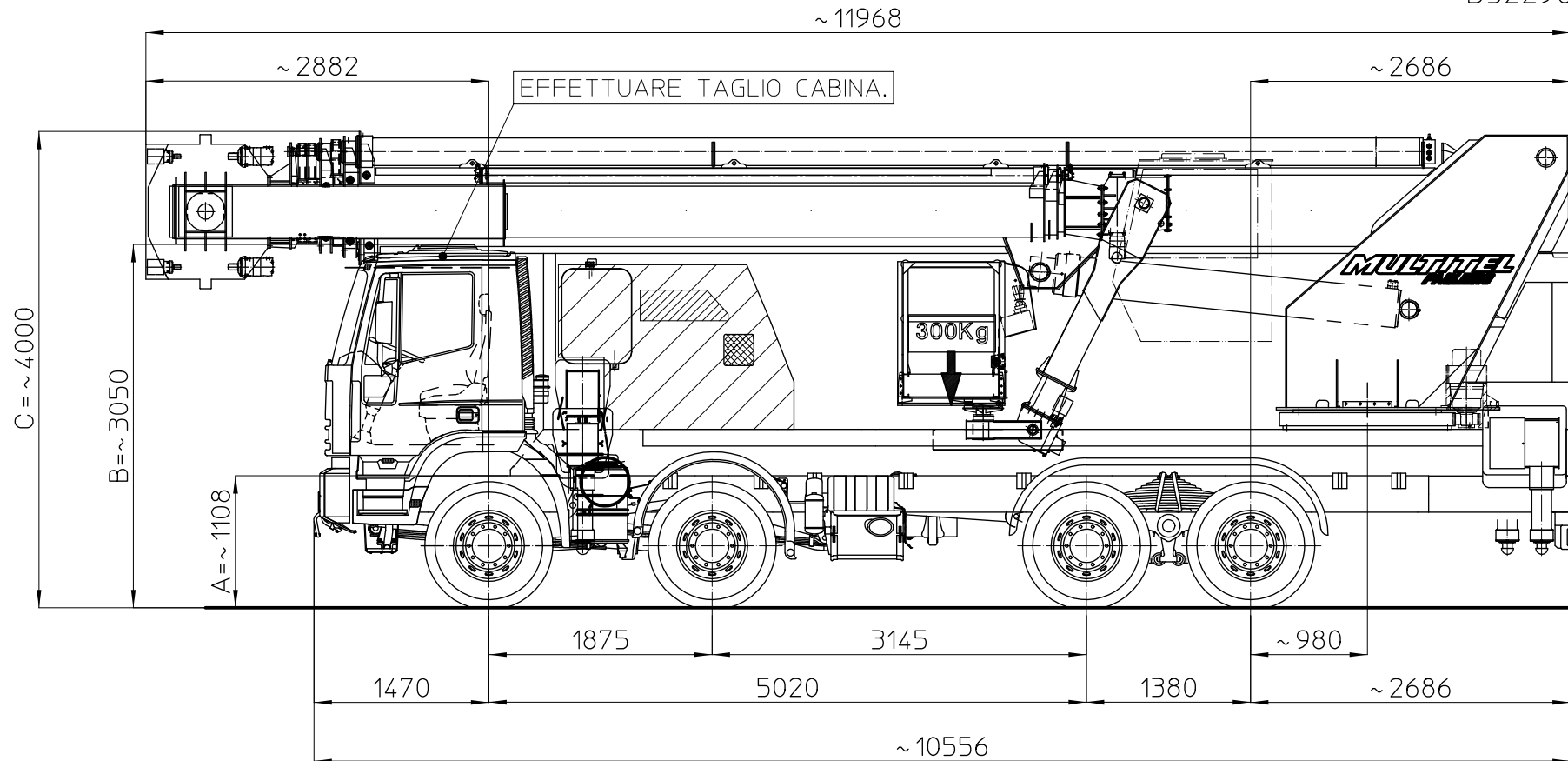

ALTEZZA VEICOLO ALLESTITO CON PNEUMATICI 315/80 R22.5

Le quote A-B sono relative alle dimensioni dell'autocarro, quindi devono essere verificate sullo stesso.
La quota C (altezza totale) e' subordinata alle quote A-B.

Les cotes A-B sont relatives aux dimensions du porteur, donc elles doivent être vérifiées sur le porteur même.
La cote C (hauteur totale) est subordonnée aux cotes A-B.

The dimensions A-B are related to the truck sizes, therefore they must be verified.
The dimension C (total height) is subject to A-B.

Die Abmessungen A-B betreffen die Fahrzeugmasse, daher sollen sie geprüft werden.
Die Abmessung C (Gesamthöhe) hängt von A-B Abmessungen ab.

	TIPO DI STABILIZZAZIONE	PORTATA CESTELLO (kg)	
		- 300 kg - senza zavorra	- 300 kg - con zavorra
DIAGRAMMI DI LAVORO	PIEDI IN SAGOMA		
	PIEDI PARZIALI	D34979	D34982
	PIEDI ESTESI	D34978	D34981
	SOTTOPONTE	D34980	D34983
CARICO UTILE DIS. STABILIZZAZIONE			
AUTOCARRO	1°ASSE	2°ASSE	
TARE A VUOTO	6875 kg	3925 kg	
MASSIMI AMMESSI	16000 kg	26000 kg	
P.T.T.	40000 kg		
NOTE:	Allestimento eseguito con zavorra asportabile dietro blocco di base		

MULTITEL J2 361 TA

D34981

Ente	Rev.	Descrizione	Data	Dis.	Confr.	Ap.AQ
MRK	0	EMISSIONE	22/06/17	L.B.		
DIAGRAMMA - SCHEDA 54/2 - Rev. 0 - 15/12/00						

300kg

P.T.T.=40000 kg + zavorra 2000 Kg
 G.V.W.=40000 kg + counterweight 2000 Kg
 P.T.A.C.=40000 kg + lest 2000 Kg
 GES. GEWICHT=40000 kg + ballast 2000 Kg

STABILIZZATORI COMPLETAMENTE ESTESI
 FULLY EXTENDED STABILIZERS
 STABILISATEURS COMPLETEMENT ETENDUS
 GANZ AUSGEFAHRENE STÜTZEN

SBRACCIO DI LAVORO 32,0 m ±5%
 WORKING OUTREACH 32,0 m ±5%
 DEPORT DE TRAVAIL 32,0 m ±5%
 SEITLICHE REICHWEITE 32,0 m ±5%

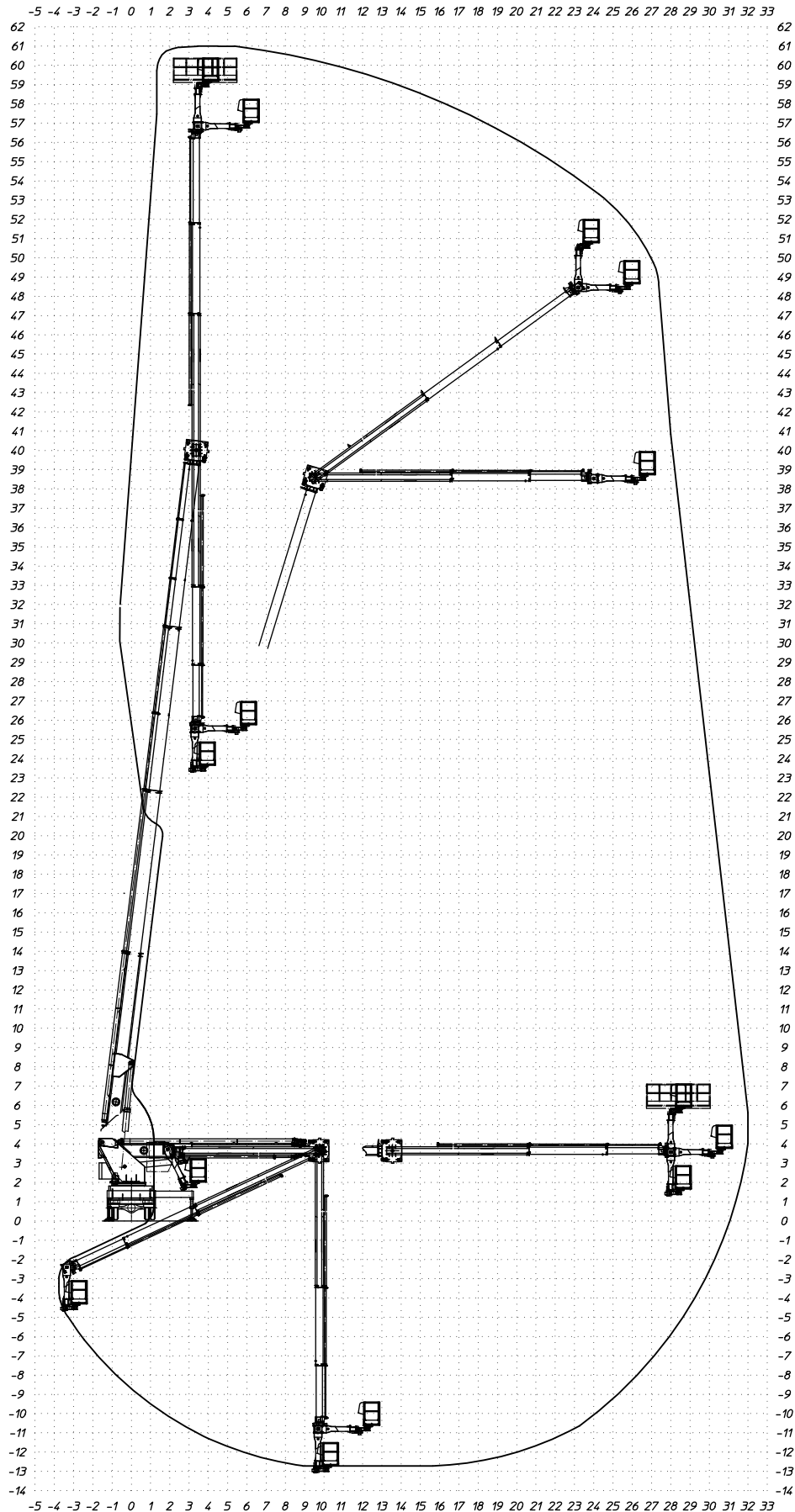

MULTITEL J2 361 TA

D34978

Ente	Rev.	Descrizione	Data	Dis.	Contr.	Ap.AQ
MRK	0	EMISSIONE	22/06/17	L.B.		
DIAGRAMMA - SCHEDA 54/2 - Rev. 0 - 15/12/00						

P.T.T.=40000 kg
 G.V.W.=40000 kg
 P.T.A.C.=40000 kg
 GES. GEWICHT=40000 kg

STABILIZZATORI COMPLETAMENTE ESTESI
 FULLY EXTENDED STABILIZERS
 STABILISATEURS COMPLETEMENT ETENDUS
 GANZ AUSGEFAHRENE STÜTZEN

SBRACCIO DI LAVORO 30,5 m ±5%
 WORKING OUTREACH 30,5 m ±5%
 DEPORT DE TRAVAIL 30,5 m ±5%
 SEITLICHE REICHWEITE 30,5 m ±5%

300Kg

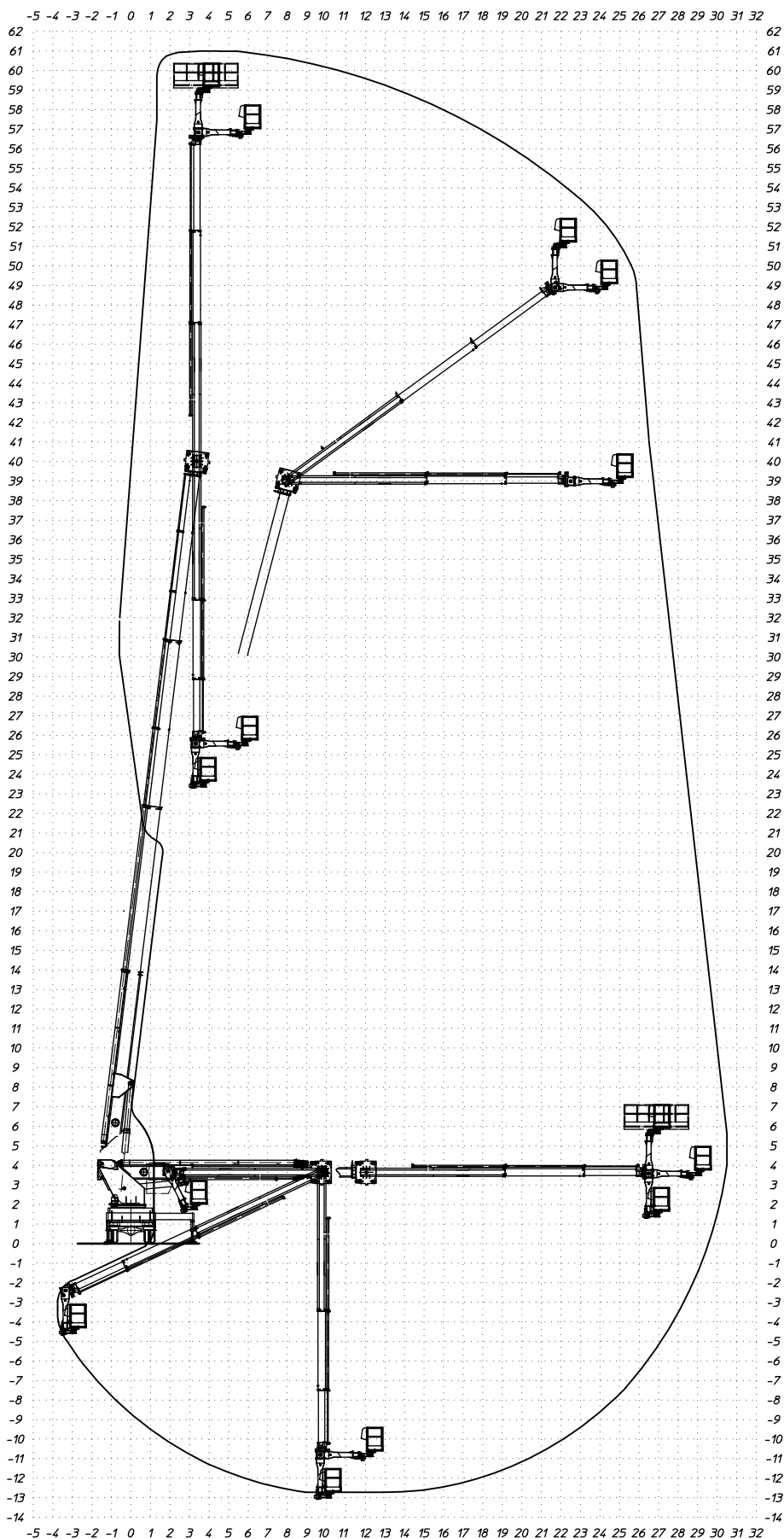

MULTITEL J2 361 TA

D34979

Ente	Rev.	Descrizione	Data	Dis.	Contr.	Ap.AQ
MRK	0	EMISSIONE	22/06/17	L.B.		
DIAGRAMMA - SCHEDA 54/2 - Rev. 0 - 15/12/00						

P.T.T.=40000 kg
 G.V.W.=40000 kg
 P.T.A.C.=40000 kg
 GES. GEWICHT=40000 kg

STABILIZZATORI PARZIALMENTE ESTESI
 PARTIALLY EXTENDED STABILIZERS
 STABILISATEURS ETENDUS PARTIELLEMENT
 PARTIAL AUSGEFAHRENE STÜTZEN

SBRACCIO DI LAVORO
 WORKING OUTREACH
 DEPORT DE TRAVAIL
 SEITLICHE REICHWEITE

300Kg

22,6 m ±5%
 22,6 m ±5%
 22,6 m ±5%
 22,6 m ±5%

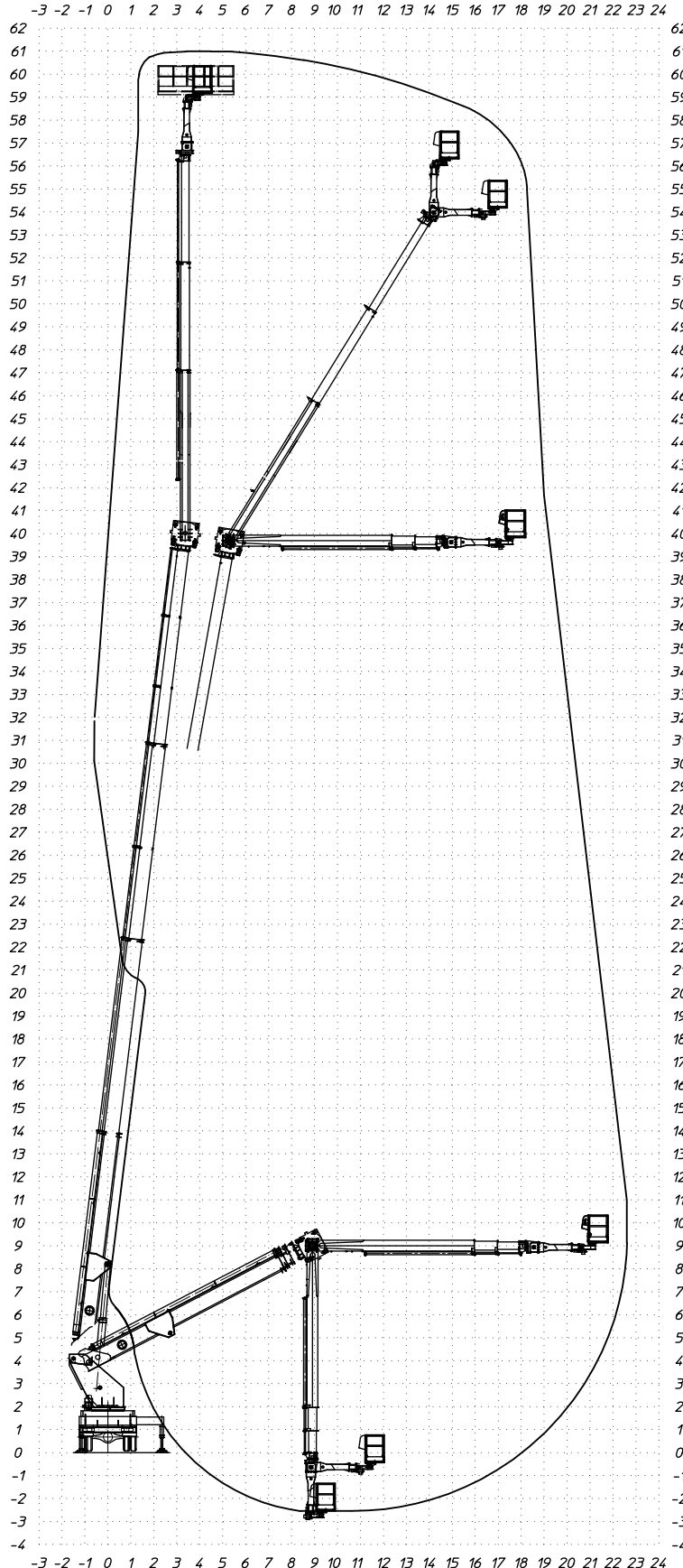

MULTITEL J2 361 TA

D34980

Ente	Rev.	Descrizione	Data	Dis.	Contr.	Ap.AQ
MRK	0	EMISSIONE	22/06/17	L.B.		
DIAGRAMMA - SCHEDA 54/2 - Rev. 0 - 15/12/00						

P.T.T.=40000 kg
 G.V.W.=40000 kg
 P.T.A.C.=40000 kg
 GES. GEWICHT=40000 kg

STABILIZZATORI PARZIALMENTE ESTESI
 PARTIALLY EXTENDED STABILIZERS
 STABILISATEURS ETENDUS PARTIELLEMENT
 PARTIAL AUSGEFAHRENE STÜTZEN

SBRACCIO DI LAVORO
 WORKING OUTREACH
 DEPORT DE TRAVAIL
 SEITLICHE REICHWEITE

300Kg

-2.8 +10.4m ±5%
 -2.8 +10.4m ±5%
 -2.8 +10.4m ±5%
 -2.8 +10.4m ±5%

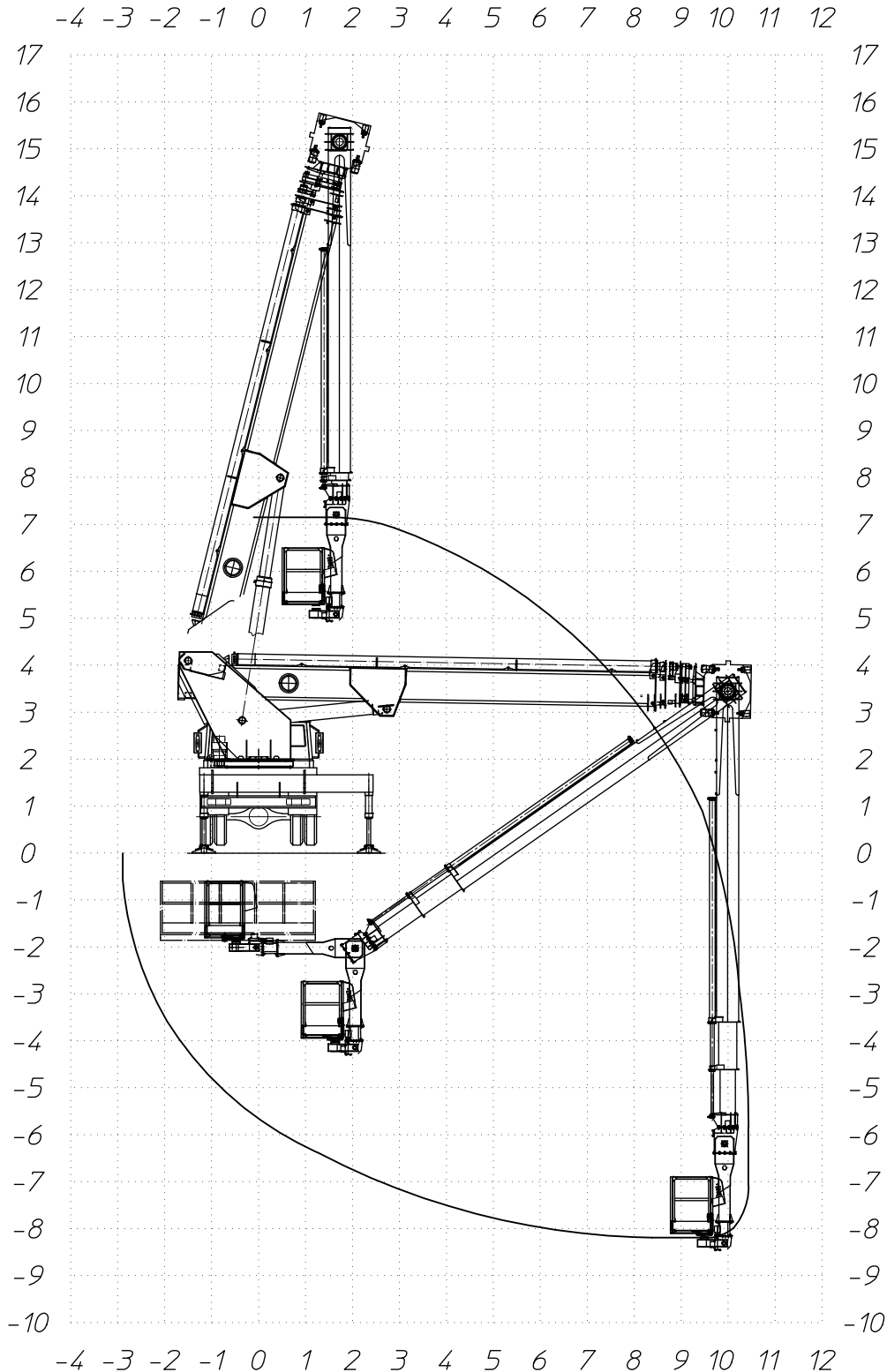

MULTITEL J2 361 TA

D34982

Ente	Rev.	Descrizione	Data	Dis.	Confr.	Ap.AQ
MRK	0	EMISSIONE	22/06/17	L.B.		
DIAGRAMMA - SCHEDA 54/2 - Rev. 0 - 15/12/00						

300Kg

P.T.T.=40000 kg + zavorra 2000 Kg
 G.V.W.=40000 kg + counterweight 2000 Kg
 P.T.A.C.=40000 kg + lest 2000 Kg
 GES. GEWICHT=40000 kg + ballast 2000 Kg

STABILIZZATORI PARZIALMENTE ESTESI
 PARTIALLY EXTENDED STABILIZERS
 STABILISATEURS ETENDUS PARTIELLEMENT
 PARTIAL AUSGEFAHRENE STÜTZEN

SBRACCIO DI LAVORO 24,6 m ±5%
 WORKING OUTREACH 24,6 m ±5%
 DEPORT DE TRAVAIL 24,6 m ±5%
 SEITLICHE REICHWEITE 24,6 m ±5%

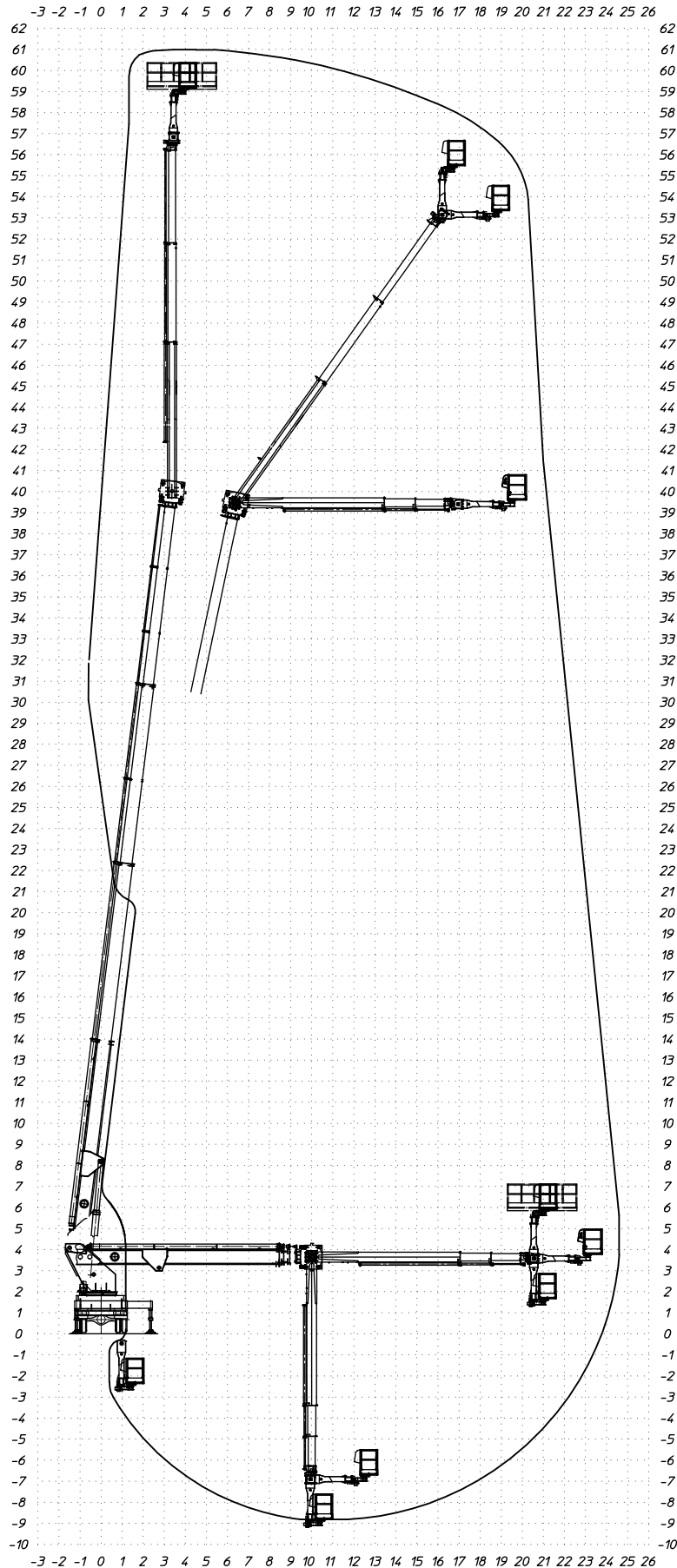

MULTITEL J2 361 TA

Ente	Rev.	Descrizione	Data	Dis.	Contr.	Ap.AQ
MRK	0	EMISSIONE	25-11-03	W.B.		
DIAGRAMMA - SCHEDA 54/2 - Rev. 0 - 15/12/00						

D34983

CLIENTE:VIDEA # 14460.
CON ZAV AGGIUNTIVA.

SBRACCIO DI LAVORO -4.1 +21.1 m ±5%
 WORKING OUTREACH -4.1 +21.1 m ±5%
 DEPORT DE TRAVAIL -4.1 +21.1 m ±5%
 SEITLICHE REICHWEITE -4.1 +21.1 m ±5%

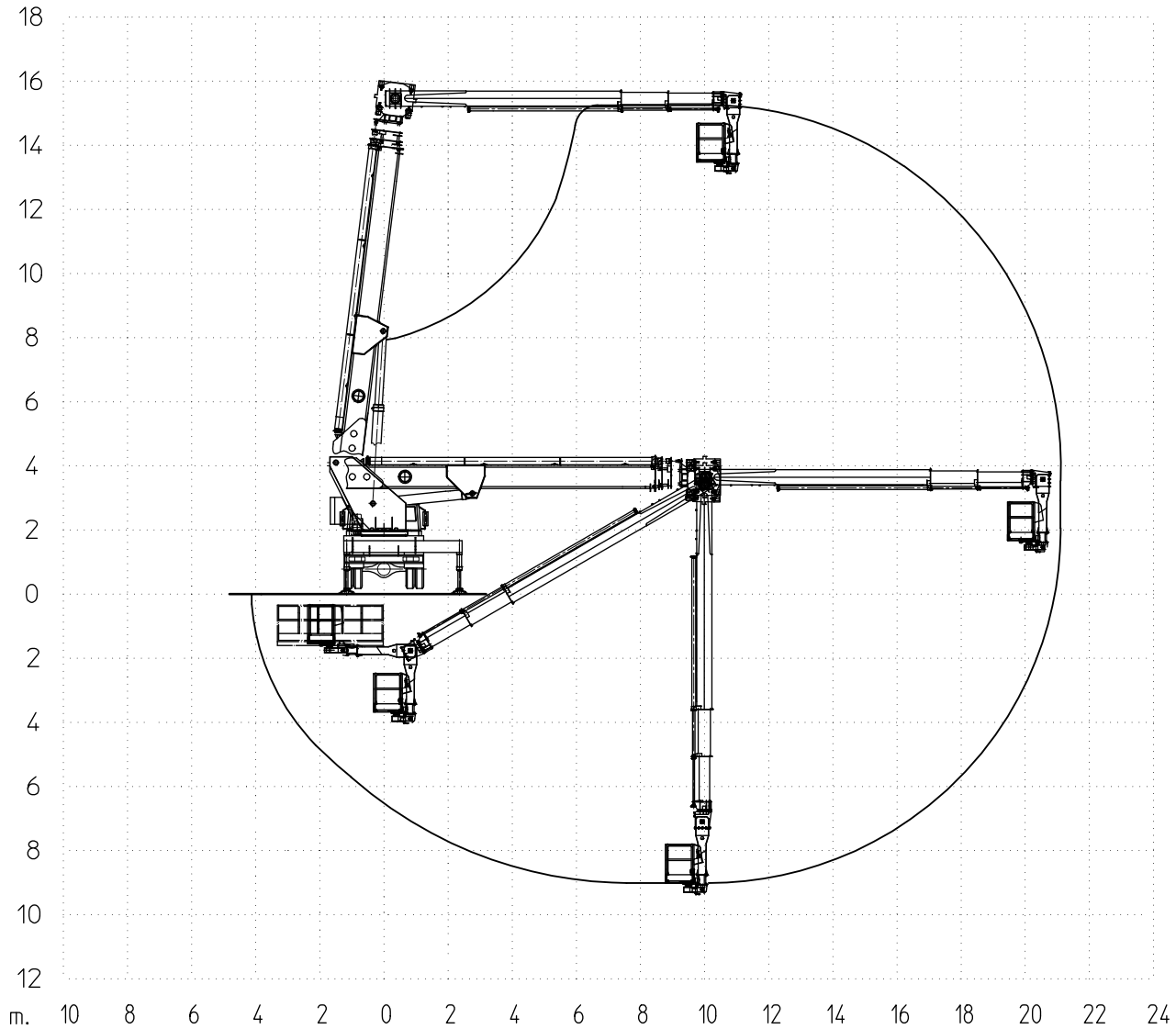

300 kg