

MANITOWOC M250

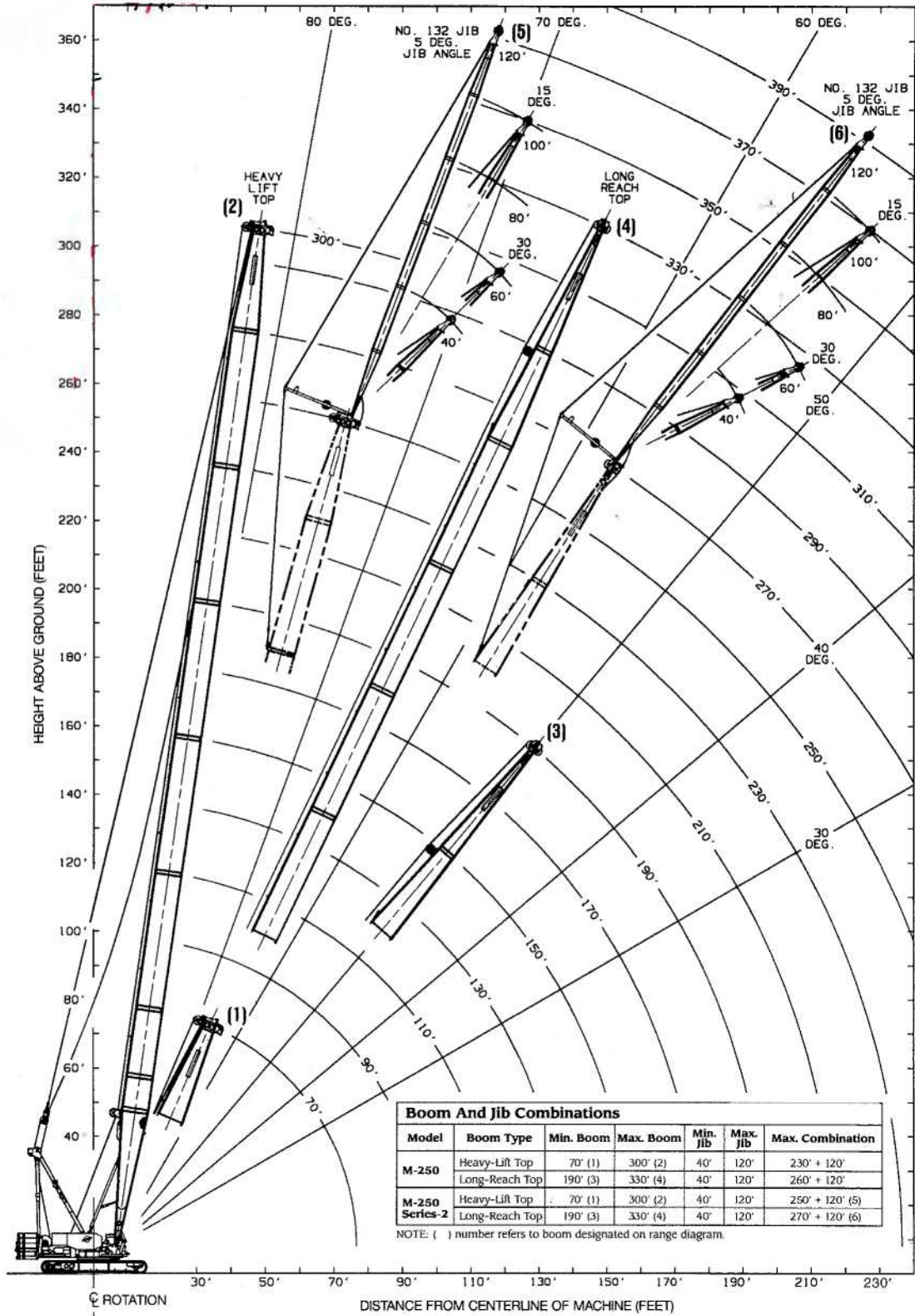

300-Ton Liftcrane ▲ 30,000-Lb. Clamshell

OUTLINE DIMENSIONS M-250 and M-250 Series-2

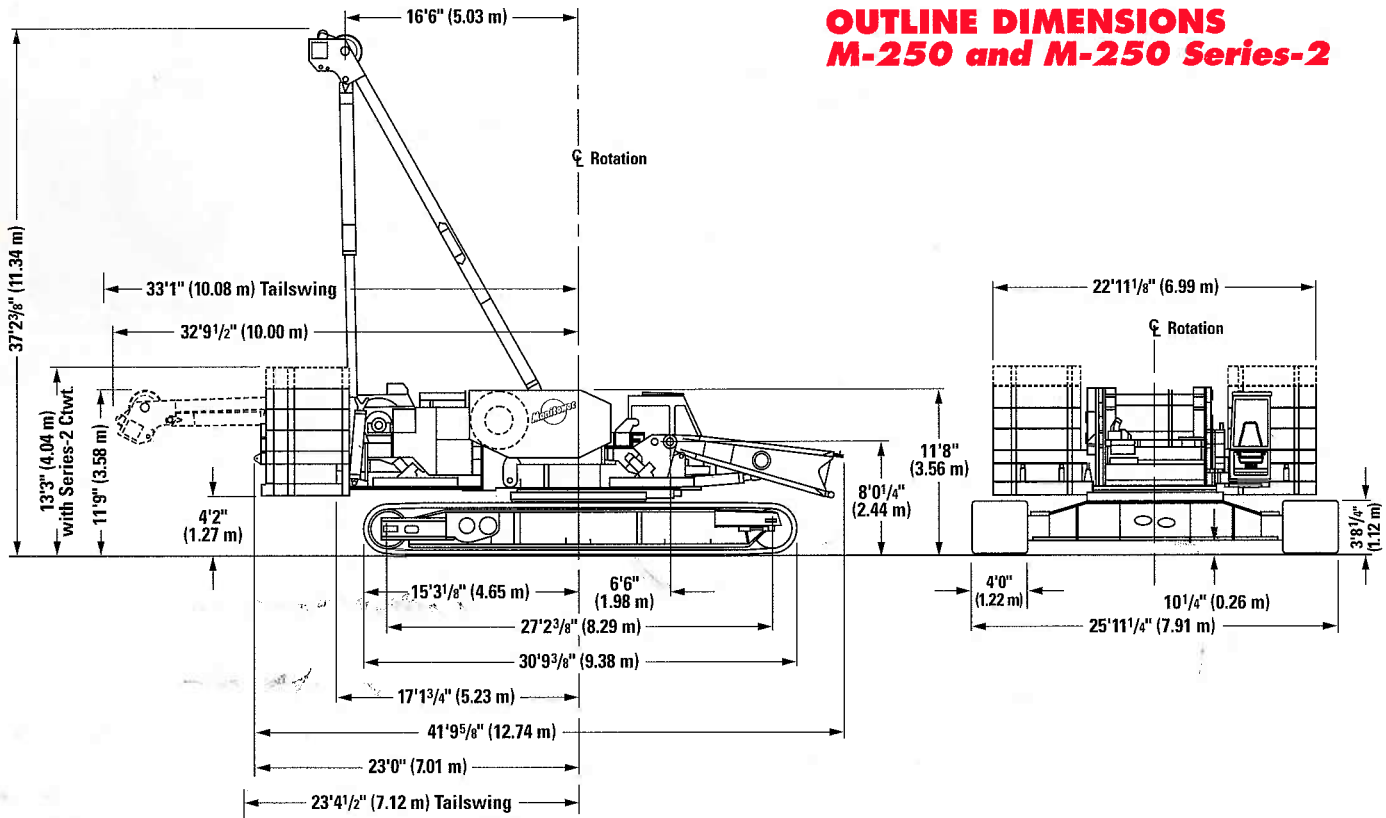

SPECIFICATIONS

UPPERWORKS

ROTATING BED: Fabricated steel rotating bed equipped with Manitowoc's patented **Fast Aligning Connection Technology (FACT™)** system for rapid attachment to rotating module on carbody. FACT system uses alignment devices, power-activated pins, and H-FACT® hydraulic quick coupler to speed crane assembly and disassembly.

DRUMS: Basic arrangement is a split rear drum-shaft assembly. Right drum 44% wide and 22½" in diameter. Left drum 18% wide and 22½" in diameter. Shaft and drums are antifriction-bearing mounted. Shaft driven by a fixed-displacement double-bank radial-piston hydraulic motor through a spur-gear reduction. Internal-expanding drum clutches are spring set, air released. External-contracting drum brakes are air applied, spring released. Parking brakes are spring set, air released. Front drums optional.

BOOM HOIST: Independent two-drum boom hoist is driven by variable-displacement hydraulic motor coupled to an integral brake and a planetary reduction. Grooved drums are 19% wide by 23" diameter. Drum-rotation indicator and ratchet-and-pawl are standard.

SWING SYSTEM: Independent swing powered by a fixed-displacement hydraulic motor coupled to an internal brake and planetary reduction mounted in the carbody assembly. Includes gear segment type swing lock.

OPERATOR'S STATION: Fully enclosed and insulated steel module mounted to the left front corner of the rotating bed. Module is equipped with sliding door, large safety glass windows on all sides and in roof. Standard equipment includes electric horn, cab space heater, dome light, fire extinguisher, air-circulating fan, and windshield wipers for upper front window, lower front window, and roof window. Module can be repositioned for transportation.

ENGINE/TRANSMISSION: Cummins N14-C450 diesel engine rated at 450 HP at 2,100 RPM provides independent power for all operations through the multi-hydraulic-pump transmission. Power system includes engine block heater (120V), ether starting aid, transmission disconnect clutch, high-silencing muffler, alcohol injector in air line, hydraulic oil cooler, radiator, and fan.

CONTROLS: Electronic-over-hydraulic controls and closed-looped hydraulics provide infinitely variable speed response in proportion to control lever movement. Manitowoc's patented **Electronically Processed Independent Control (EPIC®)** system provides micro-processor-driven control logic, pump control, onboard diagnostics, and service information. Selector switch permits load-hoist drums to be operated in either free-fall or power-down mode. Rotation indicator standard for each drum. Block up-limit controls for main and auxiliary hoist lines are standard.

LOWERWORKS

CARBODY: Connects rotating bed to crawlers. Fabricated steel rotating module mounts to single-piece carbody via a 9'8" diameter turntable bearing. Crawlers mount to the carbody with FACT connection system of power-actuated pins.

CRAWLERS: Crawler assemblies are 30'9" long, with reinforced steel frames, 48" wide cast-steel treads, and sealed "low-maintenance" intermediate rollers. Each crawler powered independently by two variable-displacement hydraulic motors and a planetary-and-spur gear reduction, that drives a chain to the crawler drive tumbler. Crawlers provide counter-rotation capability.

M-250 SELF-ASSEMBLY
 (with optional self-assembly system)

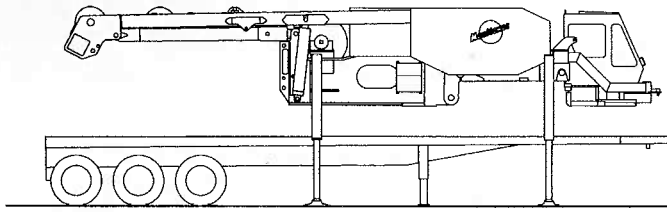

1 Operator's cab is rotated into operating position. Assembly jacks are rotated downward and used to lift upperworks off trailer.

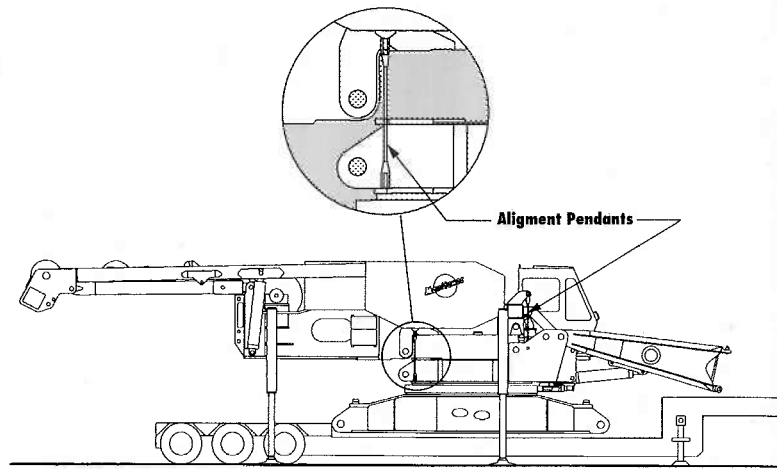

2 Carbody with rotating module is suspended and centered using alignment pendants. Upperworks is lowered, then connected to rotating module by FACT connection system's centering devices and power-activated pins. All power-activated pins used during set-up are operated by a hand-held remote control. The assembly, consisting of upperworks, rotating module, and carbody, is lowered onto supports.

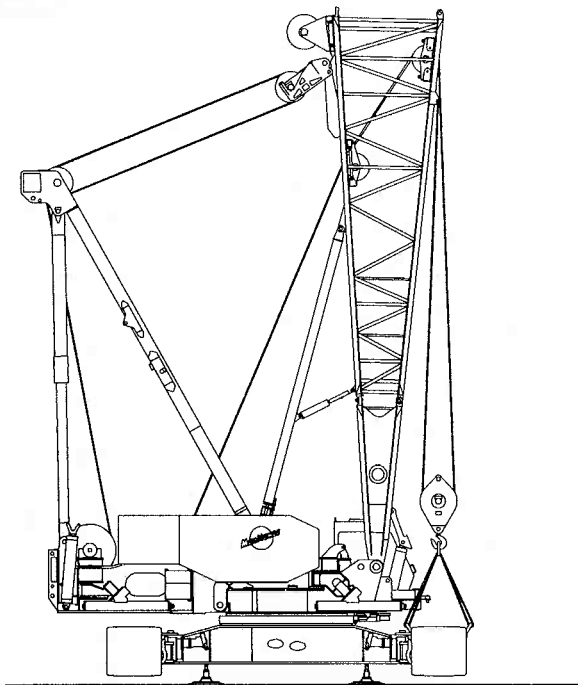
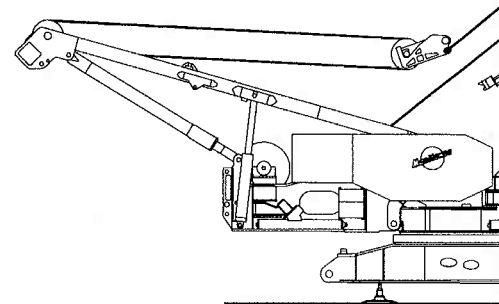

5 Gantry is pulled into upright position with boom hoist and secured by power-activated backhitch pins. Crawlers are removed from trailer and attached to carbody by FACT connection system's vertical positioners and horizontal power-activated pins.

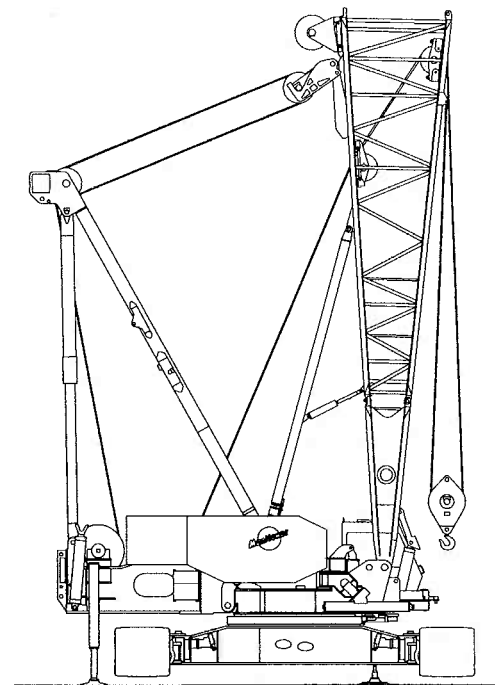

6 Rear assembly jacks are rotated downward and used to raise crane. Carbody supports are removed. Counterweight is removed from trailers and assembled.

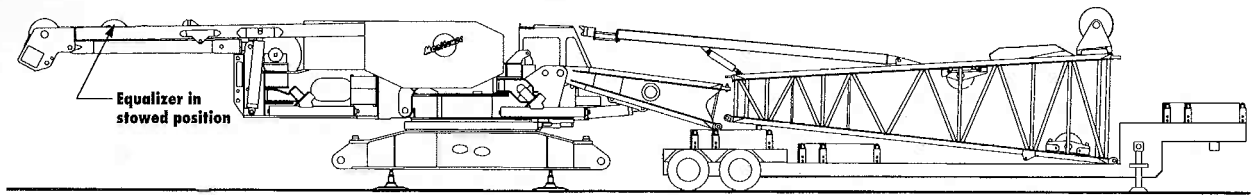

3

Upper boom butt is attached to lower boom butt by FACT connection system's vertical positioners, horizontal pins, and alignment pads. Wire rope from rear drum is reeved through wire rope guide and attached to equalizer. Boom butt is raised by a front-mounted hydraulic cylinder.

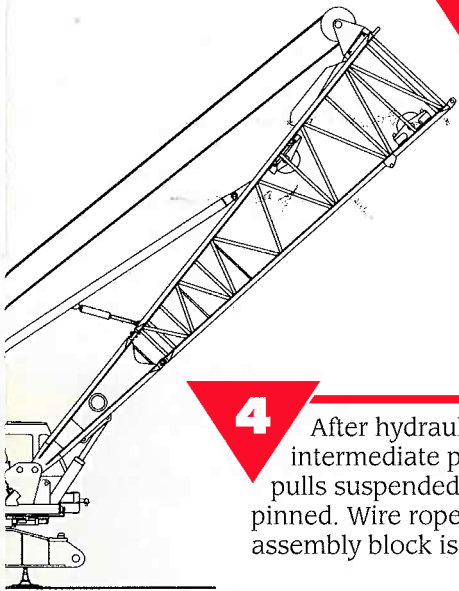

4

After hydraulic cylinders raise gantry to intermediate position, hoist line from rear drum pulls suspended equalizer to boom butt, where it is pinned. Wire rope is removed from wire rope guide, and assembly block is reeved using boom-butt sheaves.

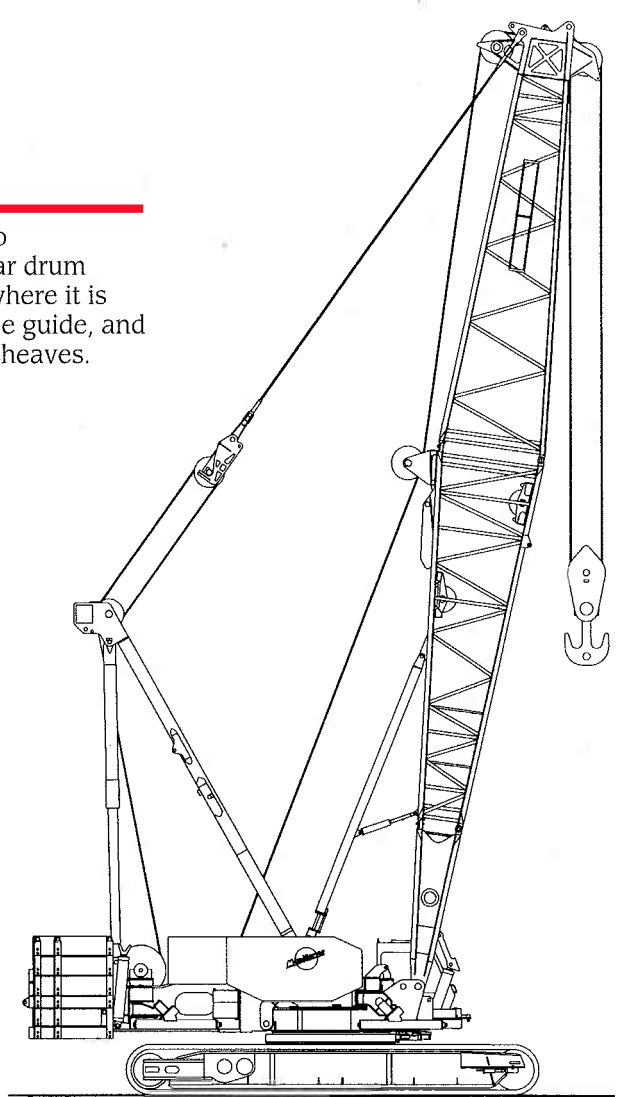
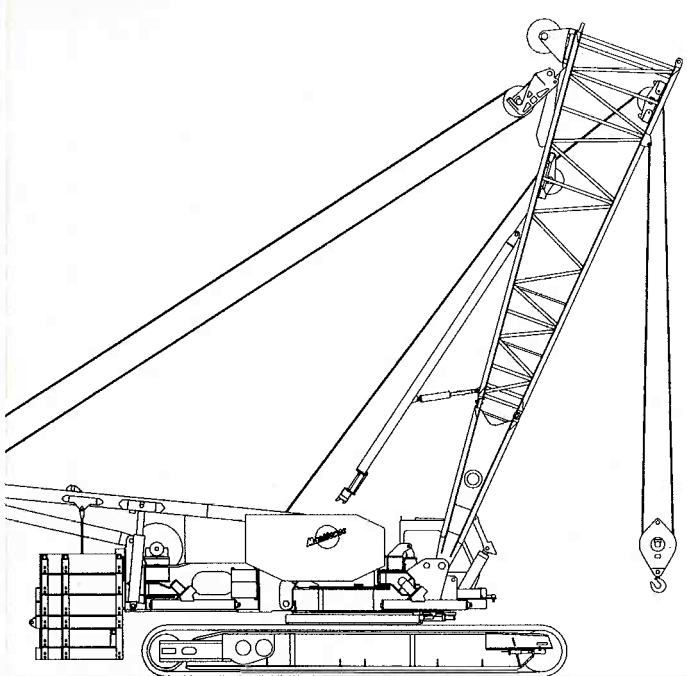

7

Crane is positioned near counterweight. Gantry is lowered. Counterweight is pendant-connected to gantry; raised into position using counterweight-raising cylinders; and attached to upperworks by power-activated pins.

8

Boom top and inserts are positioned and attached using FACT connection system. Boom pendants are attached to equalizer, and load line is reeved to load block. Crane is ready to operate.

PERFORMANCE DATA

Wire Rope Specifications					
Application	Dia.	Description	Breaking Strength	Weight	Max. Operating Length
Lift	1½"	1960 Grade, Rotation-Resistant	154,900 lb	2.70 lb/ft	2,050' Hoist 1,270' Whip
Boom Hoist	1"	6 x 26 EIPS, Alternate lay	103,400 lb	1.85 lb/ft	975'

Line Pull vs. Line Speed*						
Line Pull (Infinitely Variable)	Hoist Pump Only		Divert 1 Travel Pump		Divert 2 Travel Pumps	
	1st Layer	8th Layer	1st Layer	8th Layer	1st Layer	8th Layer
0 lb	112 fpm	194 fpm	228 fpm	390 fpm	340 fpm	584 fpm
5,000 lb	110 fpm	190 fpm	225 fpm	380 fpm	334 fpm	564 fpm
10,000 lb	108 fpm	184 fpm	221 fpm	370 fpm	327 fpm	545 fpm
15,000 lb	107 fpm	179 fpm	217 fpm	360 fpm	321 fpm	526 fpm
20,000 lb	105 fpm	174 fpm	214 fpm	350 fpm	314 fpm	506 fpm
25,000 lb	103 fpm	169 fpm	210 fpm	341 fpm	307 fpm	390 fpm
30,000 lb	101 fpm	163 fpm	207 fpm	331 fpm	300 fpm	285 fpm

*Based on 22½" diameter smooth drum.

SWING SPEED: 2.0 RPM.

GRADEABILITY: 30%.

TRAVEL SPEED: 1.25 MPH.

BOOM HOIST SPEED: 300' boom, 0° to 82°— 2 minutes, 40 seconds.

LIFTCRANE ATTACHMENT

BASIC BOOM: Liftcrane equipped with 70' No. 44 basic boom consisting of 40' two-piece butt and 30' heavy-lift top with nine 30" diameter sealed antifriction-bearing sheaves. Includes rope guides, boom-hoist wire rope, boom-angle indicator, and hook and weight ball. Boom features Manitowoc's patented FACT connection system, which uses two vertical positioners, two horizontal connection pins, and alignment pads to connect adjacent sections of boom.

Gantry with telescopic backhitch and power-activated backhitch pins.

Air-cushioned physical boom stop.

Automatic boom stop.

UPPERWORKS COUNTERWEIGHT: Assembly connected to rear of rotating bed by remote-controlled, power-activated pins. Can be installed and removed as a unit by crane's hydraulic gantry-raising cylinders. M-250 – 12 pieces, 167,000-lb. total weight. M-250 Series-2 – 15 pieces, 207,000-lb. total weight.

CARBODY COUNTERWEIGHT: Only on M-250 Series-2. Two 30,000-lb. boxes connected to carbody by hooks and manually installed pins. Can be installed and removed by crane's optional self-assembly system using boom butt.

OPTIONAL EQUIPMENT

BOOM AND JIB:

Boom No. 44

10' Insert with pendants

20' Insert with pendants

40' Insert with pendants

30' Tapered insert with pendants
(used with long-reach top)

40' Long-reach top

Jib No. 132

40' Jib with mounting parts

20' Insert with pendants

ATTACHMENTS:

30-ton single-sheave load block

60-ton two-sheave load block

100-ton three-sheave load block

300-ton nine-sheave load block

Single-sheave upper boom point (whipline)

Luffing-jib attachment

Series-2 package

MAX-ER™ attachments

X-TENDER™ attachment

RINGER® attachment

Other attachments on request

Container-handling attachment

BASIC CRANE OPTIONS:

Full-width front drum shaft

Air conditioner in operator's cab

Special paint – machinery enamel in
color other than Manitowoc standard

Bail limit control for hoist drums

Self-assembly system

Grooved laggings for liftcrane

Grooved laggings for clamshell

Caterpillar 3406B DITA engine

Load-moment indicator (LMI)

Elevated operator cab

Preparation to accept luffing jib, RINGER, and MAX-ER
attachments

EASY MOBILIZATION

M-250

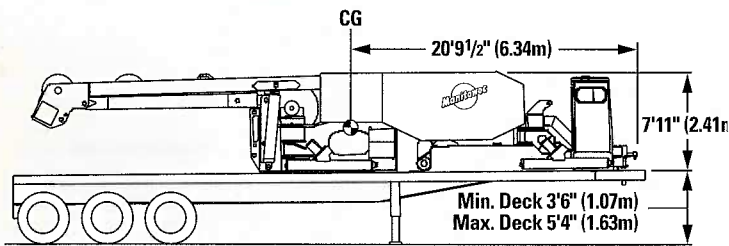

Upperworks module with operator's cab, gantry, equalizer, self-assembly jacks, and all wire rope: 84,000 lb., (without hoist and whipline wire rope: 76,235 lb.), 43'2" x 9'10" x 7'11"

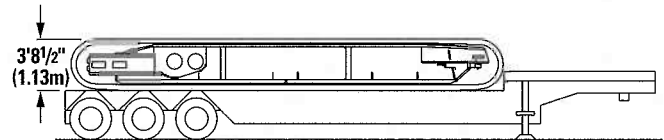

Crawler assembly: 56,545 lb. each, 30'9" x 7'3" x 3'8 1/2"

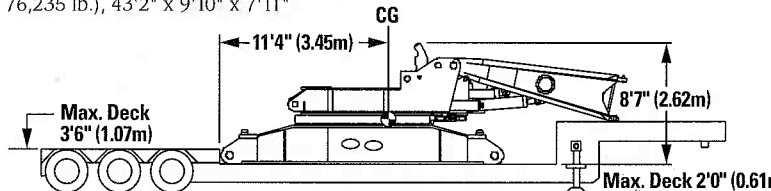

Carbody assembly, including carbody, rotating module, turntable bearing, swing drive, 12' lower boom butt, and boom-raising cylinder: 63,445 lb., 28'11" x 9'8" x 8'7"

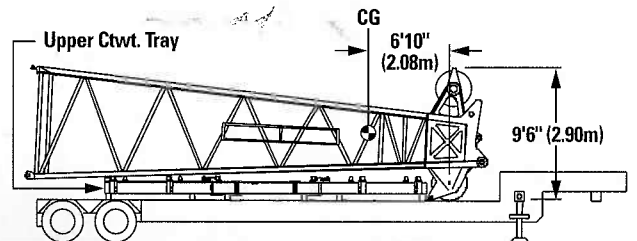
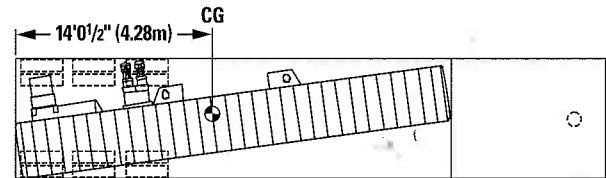

30' boom top with lower boom point, wire rope guide, and basic pendants. 12,325 lb. upper counterweight tray: 31,170 lb. Total load 43,495 lb., 33'0" x 8'6" x 9'6"

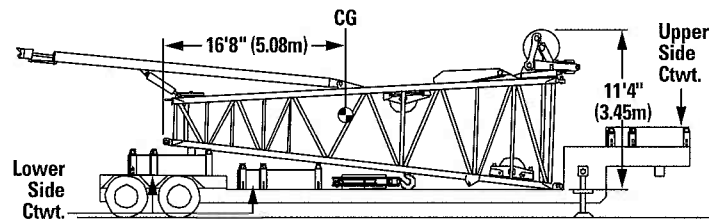

Lower side counterweights (2): 10,000 lb. each
Upper side counterweights: 10,750 lb.
28' upper boom butt with wire rope guide, self-assembly rope guides, and boom stop: 11,070 lb.
Total load: 41,295 lb., 39'2" x 8'6" x 11'4"

Max. Deck 0.53m (Eur)
Max. Deck 2'0" (USA)

Component	Weight (Lb)	Length	Width	Height
10' Boom insert with pendants	2,360	10'6"	8'6"	8'0"
20' Boom insert with pendants	3,925	20'6"	8'6"	8'0"
40' Boom insert with pendants	6,545	40'6"	8'6"	8'0"
40' Basic No. 132 jib with strut and pendants	5,780	41'11"	4'0"	3'0"
20' Jib strut with sheaves and links	1,360	20'6"	4'0"	2'7"
20' Jib insert with pendants	1,045	20'6"	4'0"	3'0"
Lower counterweight tray with links	30,500	23'3"	6'4"	2'8"
Lower side counterweights (2)	10,000 ea.	5'7"	6'4"	1'4"
Lower center counterweight (Series-2 only)	18,400	10'0"	5'3"	1'4"
Upper counterweight tray with links	31,170	23'1"	6'9"	1'4"
Upper side counterweights (6 std., 8 for Series-2)	10,750 ea.	5'11"	6'3"	1'5"
Upper center counterweights (2)	10,000 ea.	6'11"	5'6"	1'6"
Assembled counterweight (standard M-250)	167,000	23'0"	6'9"	7'8"
Assembled upperworks counterweight (Series-2)	207,000	23'0"	6'9"	9'2"
Carbody counterweights (Series-2) (2)	30,000 ea.	11'0"	6'0"	2'11"

CAPACITY: 300-ton maximum capacity. Outlifts many larger lattice-boom cranes and 400-ton telescopic-boom cranes at useful boom lengths and normal working radii.

MOBILITY: Complete M-250 Series-2 with 300' of boom and 120' of jib ships on 13 trucks.

RELIABILITY: The M-250 delivers the same performance and long life that have earned all Manitowoc cranes a worldwide reputation for reliability and high resale value.

CODE COMPLIANCE: The Manitowoc M-250 can comply with all major operating codes, including the OSHA/ANSI, DIN, Keboma, British, and French standards.



MANITOWOC ENGINEERING CO.
Division of The Manitowoc Company, Inc.
P.O. Box 70 ♦ 2401 S. 30th St. ♦ Manitowoc, WI 54221-0070
Telephone: 414-684-6621 ♦ Telefax: 414-683-6277

Continuing product improvement may change specifications without notice.

Form Adv. 7584-1 ©1996 Manitowoc Litho in U.S.A. MEC

Courtesy of CraneMarket