

# MANITEX VALLA 250 E



## Electric battery operated Arm Lift Mobile Crane Max. Capacity **Kg. 25.000**



Valla	
OUT REACH (mm)	CAPACITY (kg)
3.000	<b>11.300</b>
5.000	<b>6.300</b>
7.000	<b>4.000</b>



### TECHNICAL DATA

**CRANE FRAME:** Eight-wheel frame fabricated from preformed and welded steel plate with built-in counterweigh.

**TRACTION:** by DC 28 kw 96V reversible electric motor, controlled by inverter, electro magnetic control on disk brake.

**BATTERY:** 96V 1450Ah battery, battery meter on dashboard.

**BRAKES:** foot hydraulically operated brakes (disc on front, drums on rear wheels). Parking hand brake mechanically operated.

**SUSPENSION:** oscillating rear axle with mechanical lock.

**STEERING:** power steering operated through own hydraulic circuit by a hydraulic cylinder fitted between the articulated power unit and the crane frame allowing 120° steering fitted with safety valves and filters. 6 kW – 96 V motor driven pump.

**WHEELS:** Nr. 2 rear superelastic 3.55/65-15" - Nr. 6 front superelastic 300 R.15"

**BOOM:** boom fabricated from preformed and welded quality steel plate. Nr.4 telescoping sections: 1 fixed; 3 hydraulically telescoping. Fitted with nylon wear pads adjustable wear pads on the sides.

**BOOM CONTROL:** Distributor by proportional levers. Motor driven pump 18.5kW 96V.

**LMI:** Electronic Load Moment Indicator. Display showing lifted load, max allowed load, tilting percentage, operating radius, angle, telescope and light indicators on the operative mode.

**TOTAL WEIGHT:** approx. kg. 25.000

**MAX. CAPACITY:** kg. 25.000

**Options on request:** hydraulic winch; chain hoists; carry-deck; battery charger (on board and stand-alone); manual and hydraulic jibs; cable remote control; radio remote control; working light; fire extinguisher.

# MANITEX VALLA 250 E



The crane applies to the following std.:  
 -2006/42/CE  
 -UNEN13000  
 -I.S.P.E.S.L.

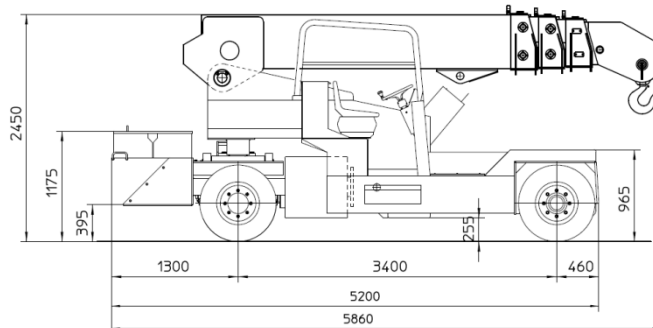
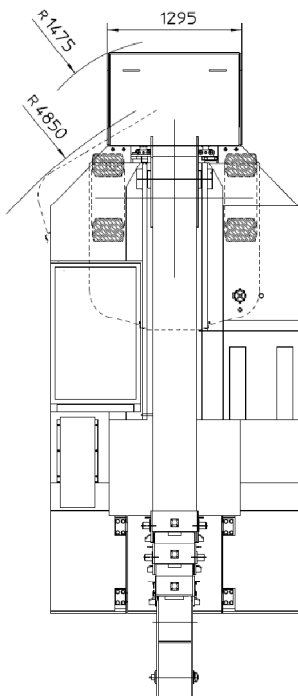
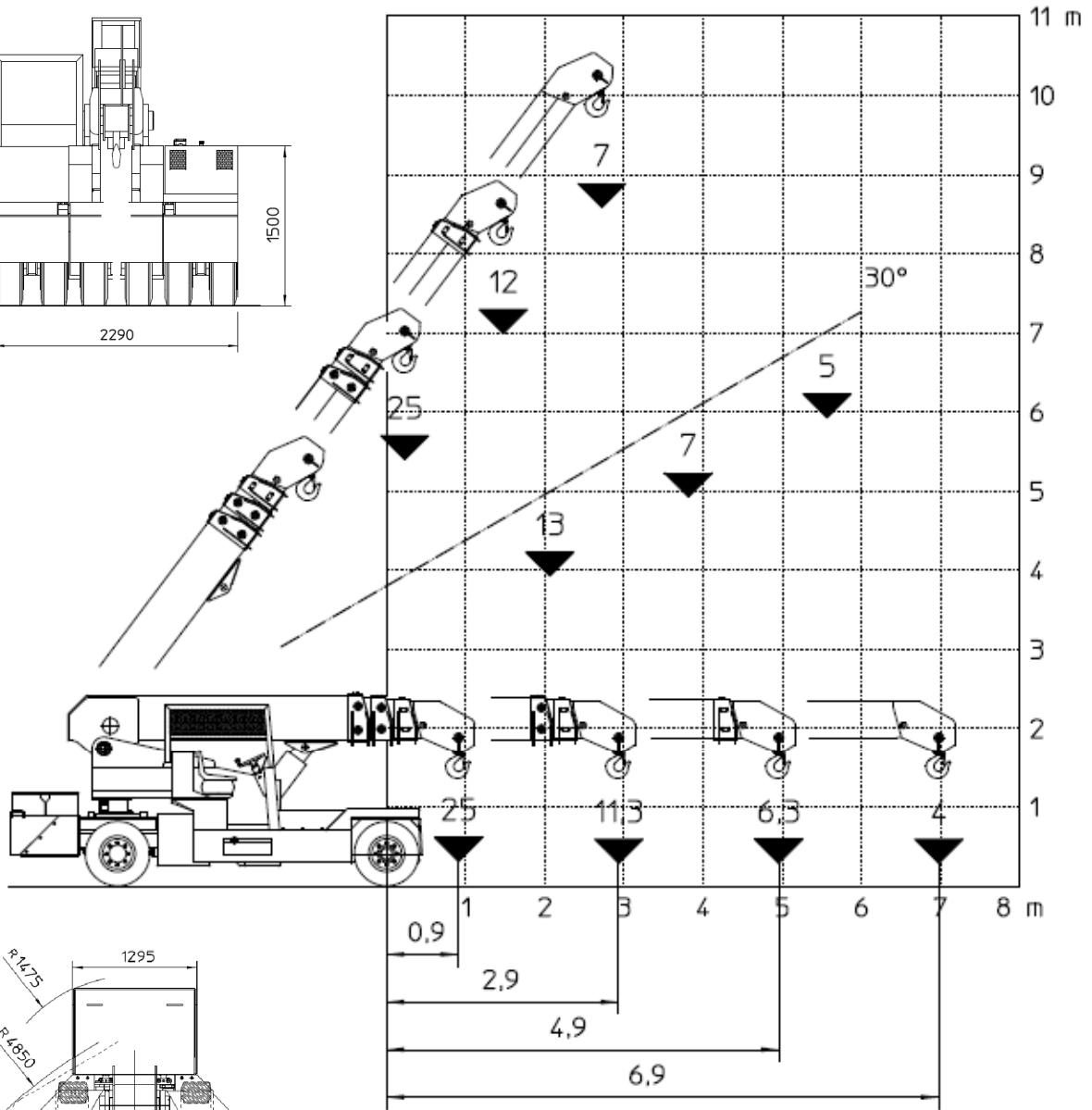
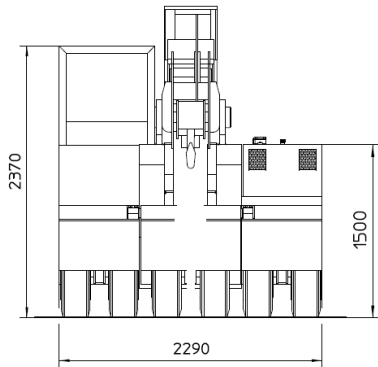

mm.

Data subject to be changed without any previous notice. Pictures may differ from technical description.



Valla – division of CVS Ferrari Srl  
 Via Piacenza, 45 – 29010 Calendasco – Piacenza – ITALIA  
 Tel. 0039 0523 762025 – 762004 – Fax 0039 0523 760531  
 Internet: [www.valla.com](http://www.valla.com) – email: [info@valla.com](mailto:info@valla.com)