

# Load Rating Chart

## *Model 5096S*



© Manitex 2000

**NOTE:** Additional copies of this Load Rating Chart can be purchased from your Manitex Distributor. When ordering, use the part number shown in the bottom left corner of this page.

## LMI OPERATING CODES

CODE	CRANE CONFIGURATION	OUTRIGGER CONFIGURATION	AREA OF OPERATION
#1	MAIN BOOM	FULLY EXTENDED	OVER REAR
#3	MAIN BOOM	FULLY EXTENDED	FULL 360°
#4	MAIN BOOM	MID POSITION	FULL 360°
#5	MAIN BOOM	RETRACTED	FULL 360°
#6	MAIN BOOM	ON TIRES	DIRECTLY OVER REAR
#7	RETRACTED JIB 0° OFFSET	FULLY EXTENDED	OVER REAR
#8	RETRACTED JIB 0° OFFSET	FULLY EXTENDED	FULL 360°
#9	RETRACTED JIB 15° OFFSET	FULLY EXTENDED	OVER REAR
#10	RETRACTED JIB 15° OFFSET	FULLY EXTENDED	FULL 360°
#11	RETRACTED JIB 30° OFFSET	FULLY EXTENDED	OVER REAR
#12	RETRACTED JIB 30° OFFSET	FULLY EXTENDED	FULL 360°
#13	EXTENDED JIB 0° OFFSET	FULLY EXTENDED	OVER REAR
#14	EXTENDED JIB 0° OFFSET	FULLY EXTENDED	FULL 360°
#15	EXTENDED JIB 15° OFFSET	FULLY EXTENDED	OVER REAR
#16	EXTENDED JIB 15° OFFSET	FULLY EXTENDED	FULL 360°
#17	EXTENDED JIB 30° OFFSET	FULLY EXTENDED	OVER REAR
#18	EXTENDED JIB 30° OFFSET	FULLY EXTENDED	FULL 360°
#19	RETRACTED JIB 0° OFFSET	MID POSITION	FULL 360°
#20	RETRACTED JIB 15° OFFSET	MID POSITION	FULL 360°
#21	RETRACTED JIB 30° OFFSET	MID POSITION	FULL 360°
#22	EXTENDED JIB 0° OFFSET	MID POSITION	FULL 360°
#23	EXTENDED JIB 15° OFFSET	MID POSITION	FULL 360°
#24	EXTENDED JIB 30° OFFSET	MID POSITION	FULL 360°
#25	PERSONNEL LIFTING MAIN BOOM	FULLY EXTENDED	FULL 360°
#26	PERSONNEL LIFTING RETR JIB 0° OFFSET	FULLY EXTENDED	FULL 360°
#27	PERSONNEL LIFTING RETR JIB 15° OFFSET	FULLY EXTENDED	FULL 360°
#28	PERSONNEL LIFTING RETR JIB 30° OFFSET	FULLY EXTENDED	FULL 360°
#29	PERSONNEL LIFTING EXTENDED JIB 0° OFFSET	FULLY EXTENDED	FULL 360°
#30	PERSONNEL LIFTING EXTENDED JIB 15° OFFSET	FULLY EXTENDED	FULL 360°
#31	PERSONNEL LIFTING EXTENDED JIB 30° OFFSET	FULLY EXTENDED	FULL 360°

### **WARNING**

1. THE OPERATOR MUST READ AND UNDERSTAND THE OWNER'S MANUAL BEFORE OPERATING THIS CRANE.
2. POSITIONING OR OPERATION OF CRANE BEYOND AREAS SHOWN ON THIS CHART IS NOT INTENDED OR APPROVED EXCEPT WHERE SPECIFIED IN OWNER'S MANUAL.
3. LOADED BOOM ANGLES AT SPECIFIED BOOM LENGTHS GIVE ONLY AN APPROXIMATION OF THE OPERATING RADIUS. THE BOOM ANGLE BEFORE LOADING SHOULD BE GREATER TO ACCOUNT FOR DEFLECTIONS. DO NOT EXCEED THE OPERATING RADIUS FOR RATED LOADS.
4. THE OPERATING RADIUS SHOWN IN THE JIB RATING CHART IS FOR FULLY EXTENDED BOOM ONLY. WHEN BOOM IS NOT FULLY EXTENDED, USE ONLY LOADED BOOM ANGLE TO DETERMINE LOAD RATING OF JIB.
5. FOR BOOM ANGLES NOT SHOWN ON JIB LOAD RATING CHART, USE RATING OF NEXT LOWER BOOM ANGLE.

## **WARNING (CONTINUED)**

6. FOR BOOM LENGTHS NOT SHOWN, USE RATING OF NEXT SHORTER OR LONGER BOOM LENGTH, WHICHEVER IS LESS. FOR RADII NOT SHOWN, USE RATING OF NEXT LONGER RADIUS.
7. CRANE LOAD RATINGS ON OUTRIGGERS ARE BASED ON FREELY SUSPENDED LOADS WITH THE MACHINE LEVELED AND STANDING ON A FIRM UNIFORM SUPPORTING SURFACE. NO ATTEMPT SHALL BE MADE TO MOVE A LOAD HORIZONTALLY ON THE GROUND IN ANY DIRECTION.
8. PRACTICAL WORKING LOADS DEPEND ON SUPPORTING SURFACE, WIND, AND OTHER FACTORS AFFECTING STABILITY SUCH AS HAZARDOUS SURROUNDINGS, EXPERIENCE OF PERSONNEL, AND PROPER HANDLING, ALL OF WHICH MUST BE TAKEN INTO ACCOUNT BY THE OPERATOR.
9. THE MAXIMUM LOAD WHICH MAY BE TELESCOPED IS LIMITED BY HYDRAULIC PRESSURE, BOOM ANGLE, AND BOOM LUBRICATION. IT IS SAFE TO ATTEMPT TO TELESCOPE ANY LOAD WITHIN THE LIMITS OF THE LOAD RATING CHART.
10. LIFTING OFF THE MAIN BOOM POINT WHILE THE SWING AROUND JIB IS ERECTED IS NOT INTENDED OR APPROVED.

## **INFORMATION**

1. DEDUCTIONS MUST BE MADE FROM RATED LOADS FOR STOWED JIB, OPTIONAL ATTACHMENTS, HOOKS, AND LOADBLOCKS (SEE DEDUCTION CHART). WEIGHTS OF SLINGS AND ALL OTHER LOAD HANDLING DEVICES SHALL BE CONSIDERED A PART OF THE LOAD.
2. LOAD RATINGS ABOVE THE HEAVY LINE ARE STRUCTURALLY LIMITED CAPACITIES. LOAD RATINGS BELOW THE HEAVY LINE ARE STABILITY LIMITED CAPACITIES AND DO NOT EXCEED 85% OF TIPPING.

## **DEFINITIONS**

1. OPERATING RADIUS IS THE HORIZONTAL DISTANCE FROM THE AXIS OF ROTATION TO THE CENTER OF THE VERTICAL HOIST LINE OR TACKLE WITH LOAD APPLIED.
2. LOADED BOOM ANGLE IS THE INCLUDED ANGLE BETWEEN THE HORIZONTAL AND LONGITUDINAL AXES OF THE BOOM BASE AFTER LIFTING RATED LOAD AT RATED RADIUS.

ALLOWABLE LINE PULL										WARNING
1 PART LINE	2 PART LINE	3 PART LINE	4 PART LINE	5 PART LINE	6 PART LINE	7 PART LINE	8 PART LINE	9 PART LINE	10 PART LINE	
										<p>ANTI-TWO-BLOCK SYSTEM MUST BE IN GOOD OPERATING CONDITION BEFORE OPERATING CRANE.</p> <p>REFER TO THE OWNER'S MANUAL.</p> <p>KEEP AT LEAST 3 WRAPS OF LOAD LINE ON THE DRUM AT ALL TIMES.</p>
10000 LBS	20000 LBS	30000 LBS	40000 LBS	50000 LBS	60000 LBS	70000 LBS	80000 LBS	90000 LBS	100000 LBS	<p>5/8" 6 X 19 CLASS (3.5:1 SF) 35,000 LBS MIN BREAKING STRENGTH</p> <p>5/8" ROT RESISTANT (5:1 SF) 50,000 LBS MIN BREAKING STRENGTH</p>

## AREA OF OPERATIONS

### ON TIRES

WHEN LIFTING ON TIRES, THE BOOM MUST BE CENTERED OVER THE REAR OF THE CRANE WITH THE SWING BRAKE AND THE HOUSELOCK ENGAGED.

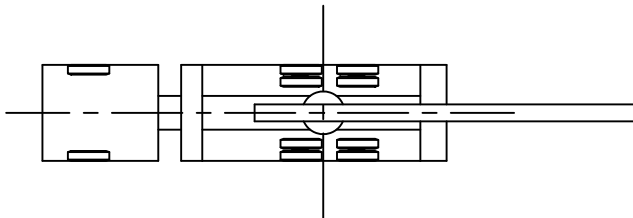

### ON OUTRIGGERS

FULL 360°

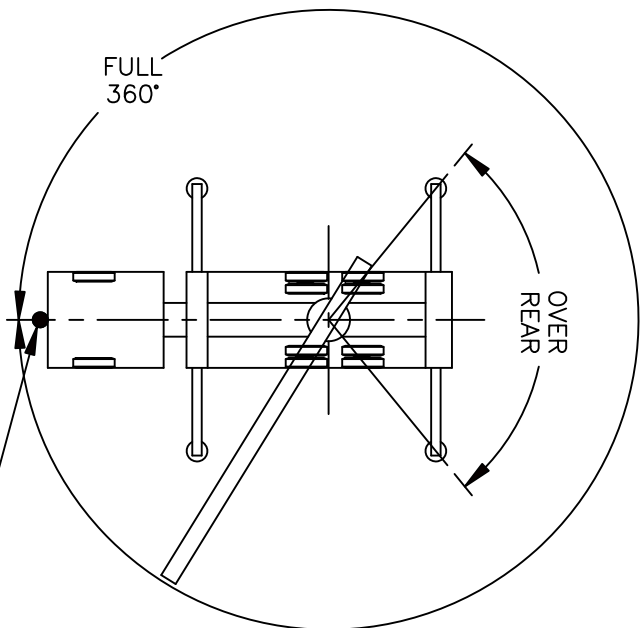

THE FRONT BUMPER STABILIZER MUST BE SET IN ACCORDANCE TO THE OPERATORS MANUAL BEFORE WORKING IN THE THE "FULL 360°" AREA.

### DEDUCTIONS FROM RATED LOADS FOR LOAD HANDLING DEVICES SUPPLIED BY MANITEX

AUXILIARY BLOCK	-----	50 LBS
ROOSTER SHEAVE	-----	70 LBS
LIFTING FROM MAIN BOOM WITH JIB STOWED OR ERECTED	-----	SEE LOAD CHART
OVERHAUL BALL	-----	SEE MANUFACTURER NAMEPLATE
LOAD BLOCK	-----	SEE MANUFACTURER NAMEPLATE

**- RANGE DIAGRAM -**

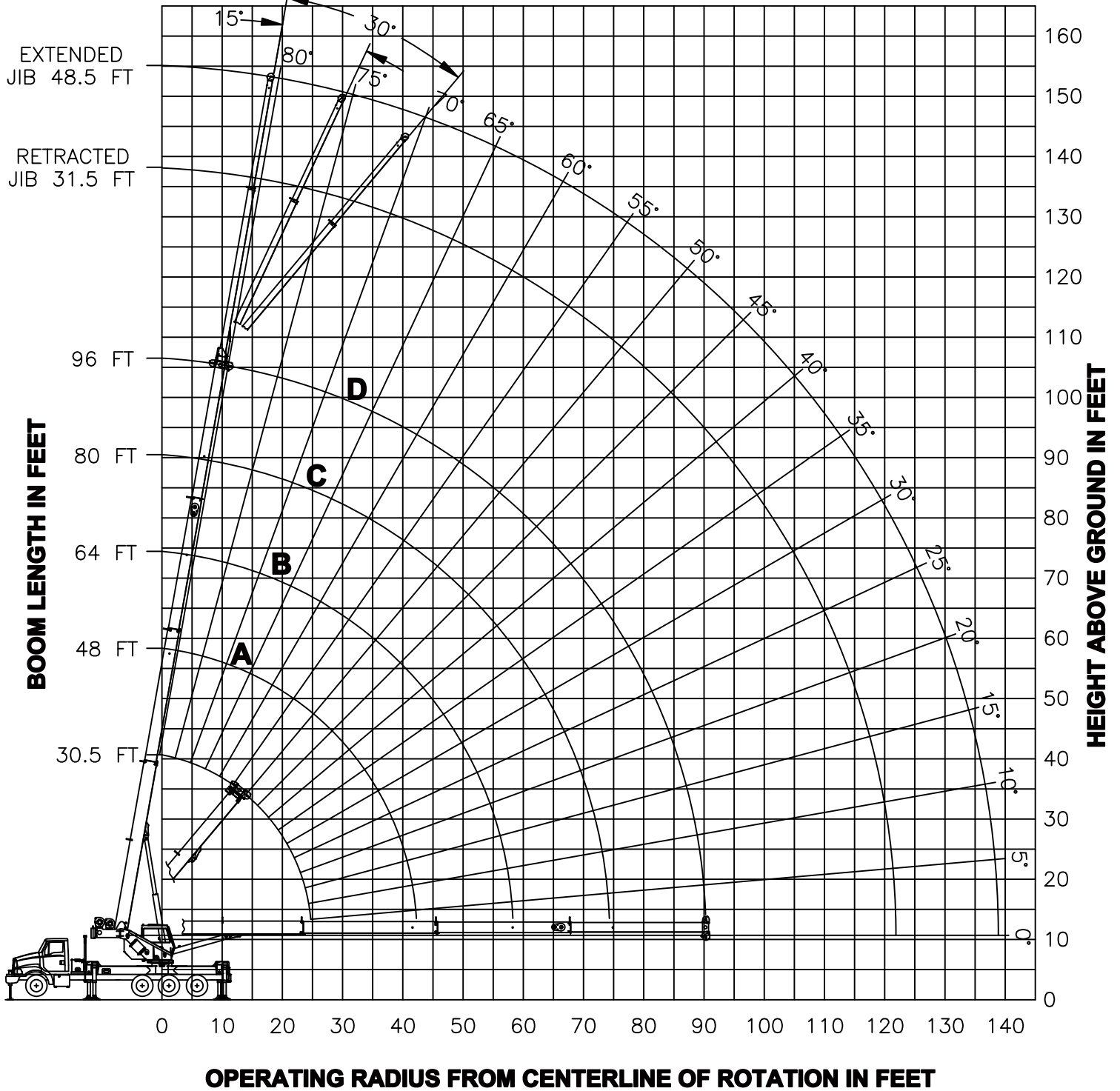

**USE THIS CHART ONLY  
WHEN ALL OUTRIGGER  
BEAMS ARE FULLY  
EXTENDED**

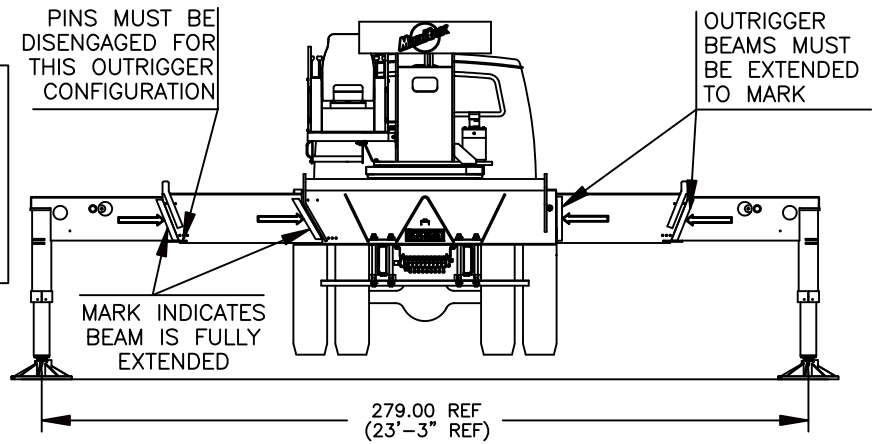

**MAIN BOOM LIFTING CAPACITIES**

LOAD RADIUS (FT)	BOOM LENGTH 30.5 FT			BOOM LENGTH 48 FT (A)			BOOM LENGTH 64 FT (B)			DEDUCTIONS FOR JIB FROM MAIN BOOM CAPACITIES
	LOADED BOOM ANGLE (DEG)	CODE 1	CODE 3	LOADED BOOM ANGLE (DEG)	CODE 1	CODE 3	LOADED BOOM ANGLE (DEG)	CODE 1	CODE 3	
		OVER REAR (LBS)	FULL 360° (LBS)		OVER REAR (LBS)	FULL 360° (LBS)		OVER REAR (LBS)	FULL 360° (LBS)	
6	69	100000	100000							
8	65	90400	90400							
10	61	80000	80000	73	51000	51000				
12	56	71800	71800	70	51000	51000	76	40000	40000	
15	49	61700	61700	66	51000	51000	73	40000	40000	
20	34	46100	46100	59	47000	47000	69	37700	37700	
25				52	36800	36800	64	30400	30400	
30				44	29480	25890	59	27040	26420	
35				34	22630	19320	53	23100	19830	
40				20	18020	15030	47	18510	15550	
45							40	15230	12550	
50							32	12750	10320	
55							21	10810	8590	
				1080 LBS			520 LBS			STOWED JIB
				3050 LBS			2520 LBS			ERECTED JIB (RETRACTED)
				3470 LBS			2720 LBS			ERECTED JIB (EXTENDED)

LOAD RADIUS (FT)	BOOM LENGTH 80 FT (C)			BOOM LENGTH 96 FT (D)			DEDUCTIONS FOR JIB FROM MAIN BOOM CAPACITIES			
	LOADED BOOM ANGLE (DEG)	CODE 1	CODE 3	LOADED BOOM ANGLE (DEG)	CODE 1	CODE 3				
		OVER REAR (LBS)	FULL 360° (LBS)		OVER REAR (LBS)	FULL 360° (LBS)				
15	77	27500	27500							
20	74	27500	27500	78	18000	18000				
25	70	24300	24300	75	18000	18000				
30	66	21280	21280	72	17500	17500				
35	62	19050	19050	69	16240	16240				
40	58	16980	15820	65	14660	14660				
45	53	15250	12810	62	13280	12970				
50	49	13000	10580	58	12130	10730				
55	44	11070	8860	54	11080	9020				
60	38	9530	7500	50	9680	7650				
65	31	8260	6380	46	8420	6540				
70	22	7200	5450	41	7360	5620				
75				36	6470	4840				
80				30	5700	4170				
85				23	5020	3580				
90				8	4410	3050				
				410 LBS			350 LBS			STOWED JIB
				2420 LBS			2360 LBS			ERECTED JIB (RETRACTED)
				2580 LBS			2490 LBS			ERECTED JIB (EXTENDED)

**USE THIS CHART ONLY  
WHEN ALL OUTRIGGER  
BEAMS ARE IN THE MID  
POSITION**

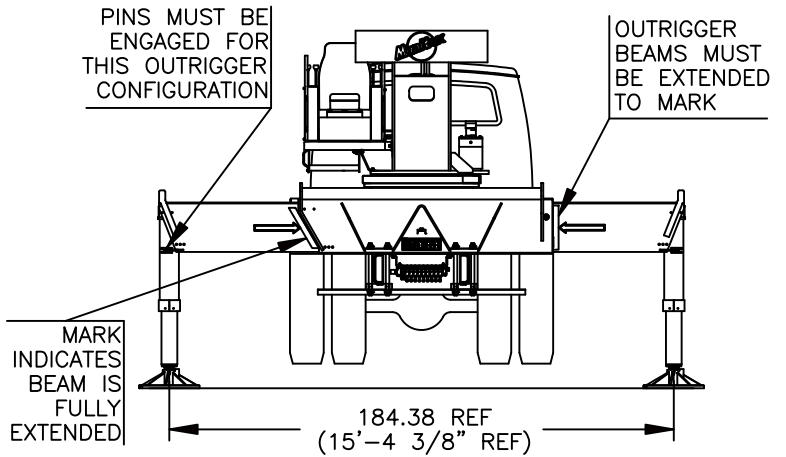

**MAIN BOOM LIFTING CAPACITIES**

LMI CODE 4										
LOAD RADIUS (FT)	BOOM LENGTH 30.5 FT		BOOM LENGTH 48 FT (A)		BOOM LENGTH 64 FT (B)		BOOM LENGTH 80 FT (C)		BOOM LENGTH 96 FT (D)	
	LOADED BOOM ANGLE (DEG)	FULL 360° (LBS)	LOADED BOOM ANGLE (DEG)	FULL 360° (LBS)	LOADED BOOM ANGLE (DEG)	FULL 360° (LBS)	LOADED BOOM ANGLE (DEG)	FULL 360° (LBS)	LOADED BOOM ANGLE (DEG)	FULL 360° (LBS)
6	69	100000								
8	65	90400								
10	61	80000	73	51000						
12	56	71800	70	51000	76	40000				
15	49	45210	66	46860	73	40000	77	27500		
20	34	24570	59	25890	69	26420	74	26730	78	18000
25			52	17020	64	17480	70	17740	75	17920
30			44	12110	59	12540	66	12780	72	12940
35			34	8980	53	9400	62	9630	69	9780
40			20	6780	47	7230	58	7450	65	7590
45					40	5640	53	5860	62	5990
50					32	4410	49	4640	58	4770
55					21	3430	44	3670	54	3810
60							38	2890	50	3020
65							31	2230	46	2380
70							22	1680	41	1830
75									36	1360
80										
	1080 LBS	690 LBS	520 LBS	410 LBS	350 LBS	DEDUCTIONS FOR JIB FROM MAIN BOOM CAPACITIES				
	3050 LBS	2680 LBS	2520 LBS	2420 LBS	2360 LBS	STOWED JIB				
	3470 LBS	2950 LBS	2720 LBS	2580 LBS	2490 LBS	ERECTED JIB (RETRACTED)				
						ERECTED JIB (EXTENDED)				

**USE THIS CHART WHEN ALL  
OUTRIGGER BEAMS ARE NOT IN  
EITHER THE MID OR FULLY  
EXTENDED POSITION**

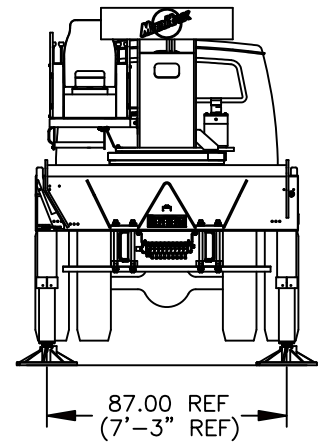

**MAIN BOOM LIFTING CAPACITIES**

LMI CODE 5											
LOAD RADIUS (FT)	BOOM LENGTH 30.5 FT		BOOM LENGTH 48 FT (A)		BOOM LENGTH 64 FT (B)		BOOM LENGTH 80 FT (C)		BOOM LENGTH 96 FT (D)		
	LOADED BOOM ANGLE (DEG)	FULL 360° (LBS)	LOADED BOOM ANGLE (DEG)	FULL 360° (LBS)	LOADED BOOM ANGLE (DEG)	FULL 360° (LBS)	LOADED BOOM ANGLE (DEG)	FULL 360° (LBS)	LOADED BOOM ANGLE (DEG)	FULL 360° (LBS)	
6	69	83880									
8	65	43110									
10	61	27900	73	29260							
12	56	19950	70	21140	76	21640					
15	49	13250	66	14310	73	14740	77	15000			
20	34	7480	59	8470	69	8860	74	9080	78	9230	
25			52	5360	64	5720	70	5930	75	6070	
30			44	3410	59	3770	66	3970	72	4100	
35			34	2070	53	2440	62	2630	69	2760	
40			20	1070	47	1470	58	1660	65	1780	
		1080 LBS	690 LBS		520 LBS		410 LBS		350 LBS		STOWED JIB

DEDUCTIONS FOR JIB FROM MAIN BOOM CAPACITIES

**WARNINGS**

1. THE JIB MUST BE IN THE STOWED POSITION, IF SO EQUIPPED, WHEN USING THIS OUTRIGGER CONFIGURATION.

**USE THIS CHART  
WHEN PICKING  
LOADS ON TIRES**

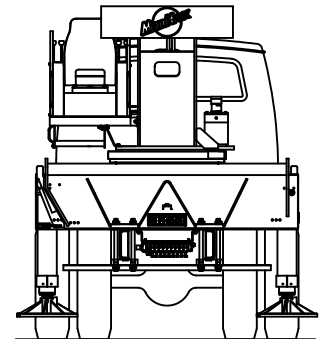

**ON TIRE CAPACITIES**

**WARNINGS**

LMI CODE 6			
LOAD RADIUS (FT)	MAX BOOM LENGTH (FT)	BOOM DIRECTLY OVER REAR (LBS)	STOWED JIB DEDUCTION (LBS)
10	30.5	12000	1080
12	30.5	11000	1080
15	30.5	9500	1080
20	48 (A)	7500	690
25	48 (A)	5000	690
30	48 (A)	3500	690
35	48 (A)	2500	690
40	48 (A)	1600	690

1. CRANE LOAD RATINGS ON TIRES ARE BASED ON THE CRANE BEING LEVEL AND TRAVELING ON A FIRM UNIFORM SURFACE (BLACK TOP, CONCRETE OR SIMILAR SURFACE).
2. TIRES MUST BE INFLATED TO 120 PSI FOR PICKING ON TIRES. CONSULT TRUCK MANUAL FOR PROPER INFLATION PROCEDURE.
3. THE JIB MUST BE IN THE STOWED POSITION, IF SO EQUIPPED, WHEN PICKING ON TIRES.
4. WHEN LIFTING ON TIRES, THE BOOM MUST BE CENTERED OVER THE REAR OF THE CRANE WITH THE SWING BRAKE AND THE HOUSELOCK ENGAGED.
5. KEEP THE LOAD CLOSE TO THE GROUND AND RESTRAINED FROM SWINGING.
6. WHEN THE RADIUS IS BETWEEN LISTED VALUES, USE THE SMALLER OF THE TWO LOAD RATINGS.
7. DO NOT OPERATE AT LONGER RADII THAN THOSE LISTED ON THE LOAD CHART.



**USE THIS CHART ONLY  
WHEN ALL OUTRIGGER  
BEAMS ARE FULLY  
EXTENDED**

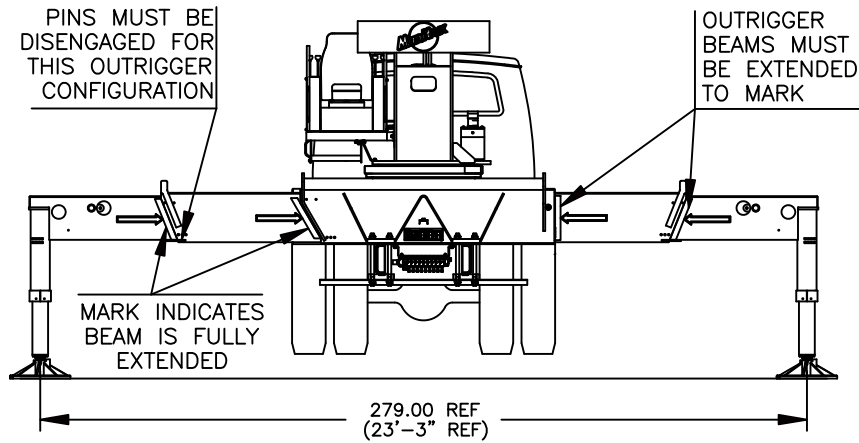

**32 FT RETRACTED JIB LIFTING CAPACITIES**

LOAD RADIUS (FT)	LOADED BOOM ANGLE (DEG)	0° OFFSET		15° OFFSET			30° OFFSET		
		CODE 7	CODE 8	LOADED BOOM ANGLE (DEG)	CODE 9	CODE 10	LOADED BOOM ANGLE (DEG)	CODE 11	CODE 12
		OVER REAR (LBS)	FULL 360° (LBS)		OVER REAR (LBS)	FULL 360° (LBS)		OVER REAR (LBS)	FULL 360° (LBS)
35	75	8500	8500						
40	73	8500	8500	76	7600	7600			
45	71	8320	8320	74	7600	7600	76	5900	5900
50	68	7790	7790	72	7140	7140	74	5900	5900
55	66	7290	7290	69	6700	6700	72	5700	5700
60	63	6830	6830	66	6280	6280	69	5520	5520
65	61	6380	6380	64	5900	5900	66	5350	5350
70	58	5980	5650	61	5550	5550	63	5200	5200
75	55	5610	4850	58	5240	5200	60	5000	5000
80	52	5270	4180	55	4960	4480	57	4760	4720
85	49	4970	3590	52	4700	3860	54	4540	4060
90	46	4410	3080	49	4460	3310	51	4330	3480
95	42	3890	2630	45	4080	2830	47	4150	2970
100	38	3420	2220	41	3590	2400	43	3700	2510
105	34	3010	1870	37	3150	2010	38	3220	2090
110	29	2630	1540	32	2740	1650	32	2780	1700
115	23	2290	1250	25	2360	1320	24	2360	1320
120	14	1980	980	14	2000	1000			

**USE THIS CHART ONLY  
WHEN ALL OUTRIGGER  
BEAMS ARE FULLY  
EXTENDED**

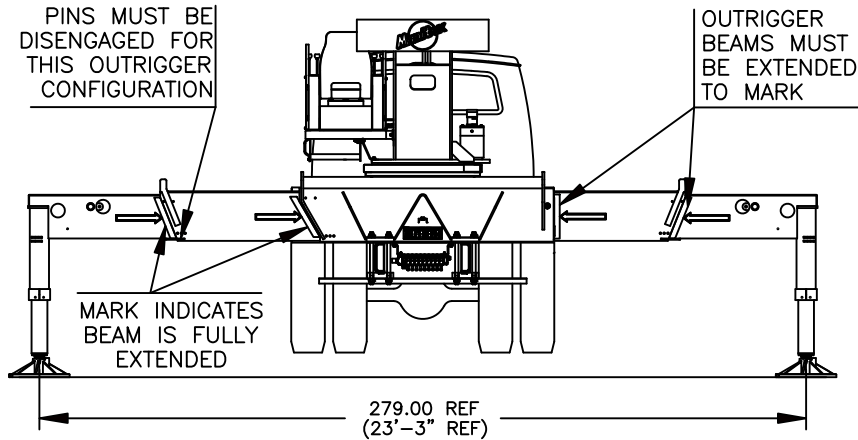

**49 FT EXTENDED JIB LIFTING CAPACITIES**

LOAD RADIUS (FT)	LOADED BOOM ANGLE (DEG)	0° OFFSET		15° OFFSET			30° OFFSET		
		CODE 13	CODE 14	LOADED BOOM ANGLE (DEG)	CODE 15	CODE 16	LOADED BOOM ANGLE (DEG)	CODE 17	CODE 18
		OVER REAR (LBS)	FULL 360° (LBS)		OVER REAR (LBS)	FULL 360° (LBS)		OVER REAR (LBS)	FULL 360° (LBS)
40	75	5600	5600						
45	73	5600	5600	77	4530	4530			
50	71	5600	5600	75	4530	4530			
55	69	5600	5600	73	4300	4300	77	3350	3350
60	67	5300	5300	71	4080	4080	75	3350	3350
65	65	4960	4960	69	3900	3900	73	3230	3230
70	63	4670	4670	67	3710	3710	71	3120	3120
75	61	4400	4400	65	3550	3550	68	3020	3020
80	58	4160	4160	62	3410	3410	66	2930	2930
85	55	3940	3940	60	3270	3270	63	2850	2850
90	53	3730	3670	57	3150	3150	60	2770	2770
95	50	3550	3210	54	3030	3030	57	2710	2710
100	47	3380	2800	51	2930	2930	54	2650	2650
105	44	3230	2440	48	2830	2710	51	2600	2600
110	41	3090	2110	45	2750	2350	48	2550	2530
115	38	2850	1820	42	2670	2030	44	2520	2170
120	34	2540	1550	38	2600	1730	40	2510	1830
125	30	2260	1310	33	2400	1450	34	2460	1520
130	25	1990	1080	28	2100	1180	27	2110	1200
135	18	1750	870	20	1800	930			

**USE THIS CHART ONLY  
WHEN ALL OUTRIGGER  
BEAMS ARE IN THE MID  
POSITION**

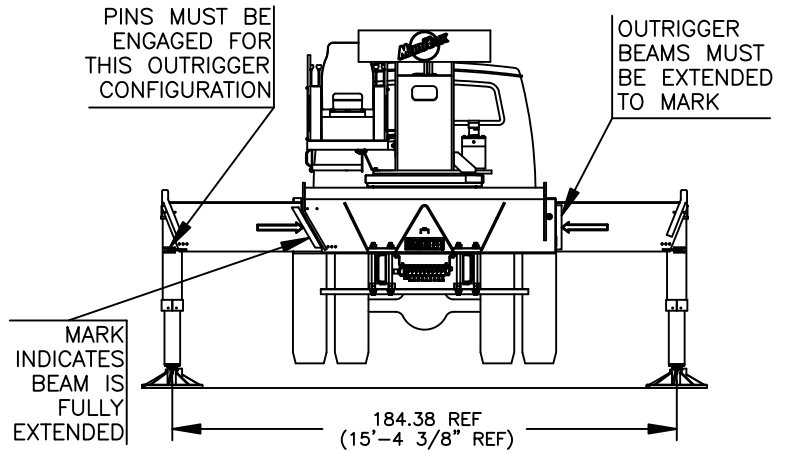

**32 FT RETRACTED JIB LIFTING CAPACITIES**

LOAD RADIUS (FT)	0° OFFSET		15° OFFSET		30° OFFSET	
	LOADED BOOM ANGLE (DEG)	CODE 19	LOADED BOOM ANGLE (DEG)	CODE 20	LOADED BOOM ANGLE (DEG)	CODE 21
		FULL 360° (LBS)		FULL 360° (LBS)		FULL 360° (LBS)
35	75	8500				
40	73	7640	76	7600		
45	71	6000	74	6670	76	5900
50	68	4740	72	5320	74	5830
55	66	3760	69	4260	72	4700
60	63	2960	66	3400	69	3780
65	61	2300	64	2690	66	3010
70	58	1740	61	2090	63	2370
75	55	1270	58	1570	60	1820
80	52	860	55	1130	57	1340
85					54	920

**49 FT EXTENDED JIB LIFTING CAPACITIES**

LOAD RADIUS (FT)	0° OFFSET		15° OFFSET		30° OFFSET	
	LOADED BOOM ANGLE (DEG)	CODE 22	LOADED BOOM ANGLE (DEG)	CODE 23	LOADED BOOM ANGLE (DEG)	CODE 24
		FULL 360° (LBS)		FULL 360° (LBS)		FULL 360° (LBS)
40	75	5600				
45	73	5600	77	4530		
50	71	5400	75	4530		
55	69	4390	73	4300	77	3350
60	67	3580	71	4080	75	3350
65	65	2910	69	3490	73	3230
70	63	2340	67	2870	71	3120
75	61	1860	65	2340	68	2750
80	58	1450	62	1870	66	2240
85	55	1090	60	1470	63	1790
90			57	1120	60	1400
95					57	1050