

STANDARD COMPONENTS INCLUDE:

Boom, boom hoist cylinder, 2-speed winch, load line and 5 ton (4,5 mt) overhaul ball, turret, pedestal, dual operator control stations, LMI & ATB protection systems, sub-frame, a-frame link outriggers, a-frame rear stabilizers, hydraulic reservoir and boom rest.

HYDRAULICS

- 8-Bolt direct mounted PTO with SAE B or SAE BB output
- Three-section gear pump, SAE BB input (standard)

Pump Section	2000 RPM	2000 RPM
Shaft End Pump:	32.4 GPM @ 100 PSI	123 LPM @ 100 PSI
Center Pump:	20.6 GPM @ 100 PSI	78 LPM @ 100 PSI
Cover End Pump:	10 GPM @ 100 PSI	38 LPM @ 100 PSI

- Hydraulic reservoir - 70 gallon (265 liter) capacity

WARNING SYSTEMS

- Wireless LMI with display and crane function shut-offs for overload protection
- Wireless anti-two block system

OPTIONS

- Hydraulic oil cooler
- Wired LMI and ATB system
- 22' (6,7 m) Flatbed - wood or 1/8" steel deck
- 22' (6,7 m) Heavy hauler flatbed - 3/16" steel deck w/rub rails
- 24" (610 mm) Bulkhead
- 29' (8,8 m) Fixed jib
- Rotation resistant wire rope, 9/16" (14,3 mm) diameter
- Load block - 1 & 3 sheave options
- Front center stabilizer for 360° work area
- Three section vane pump, SAE B input

BOOM

- 26 Ton (23 mt) capacity @ 5' (1,5 m) radius
- 4-Section 101' (30,8 m) proportional boom
- 3-Sheave quick reeve boom point

HOIST

- Maximum theoretical line speed 300 fpm (91 mpm)
- Maximum theoretical bottom-layer line pull 11,500 lb (5,216 kg)
- Wire Rope – 300' (91,4 m) of 9/16" (14,3 mm) diameter 6 x 25 EIPS IWRC

In order to ensure continuous improvement, Manitex reserves the right to change design and specifications without notice.

- Hose reel - boom mounted
- Toolboxes
 - 24" L x 20" W x 18" H (610 mm x 508 mm x 457 mm)
 - 48" L x 18" W x 18" H (1220 mm x 457 mm x 457 mm)
- 2-Person gravity leveled non-rotating basket - 600 lb (272 kg) capacity
- 2-Person gravity leveled rotating (manual) basket - 1,200 lb (544 kg) capacity
- 4-Function radio remote crane control system
- Wireless load cell and display for load monitoring (included with jib)

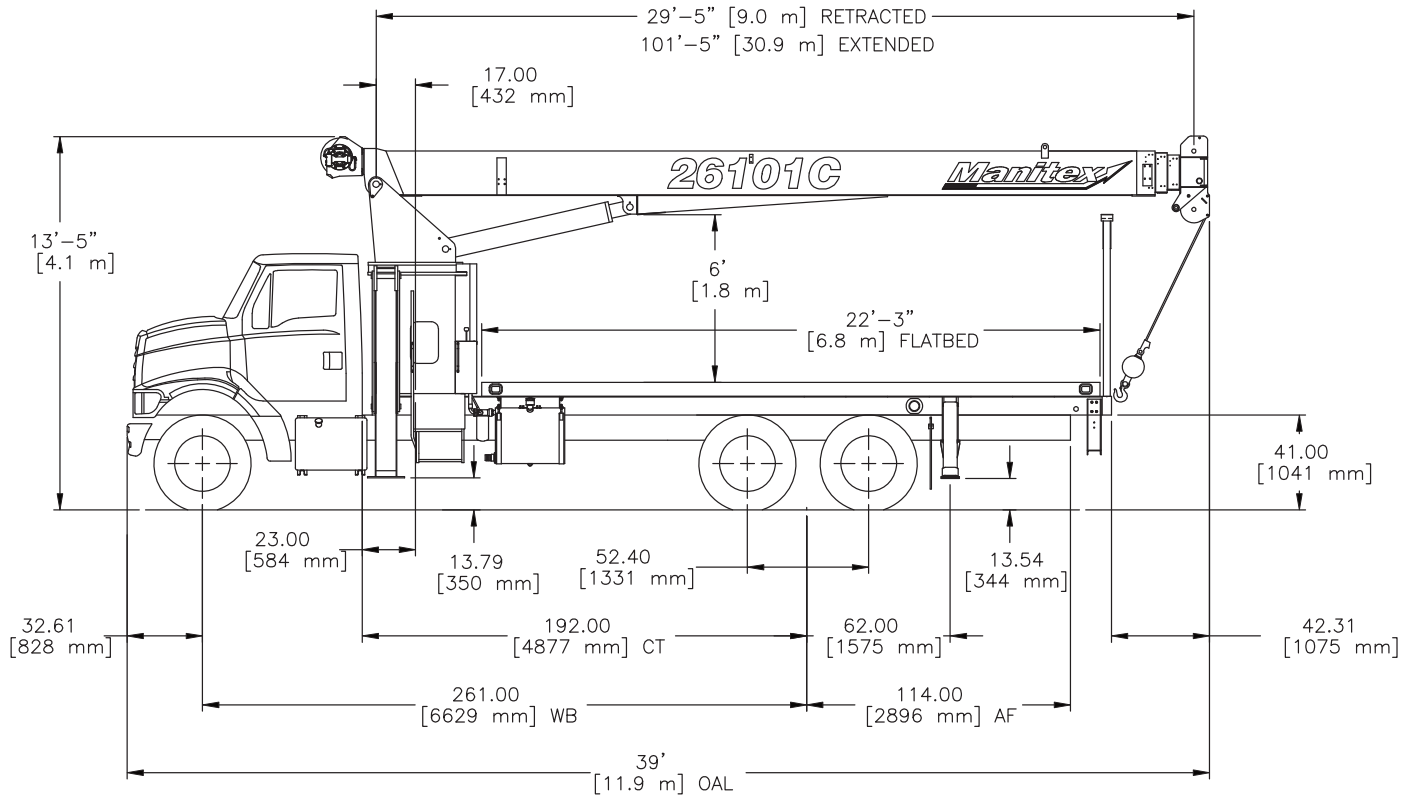

CHASSIS DATA	26101C
Wheelbase (WB)	261" 6 629 mm
Cab to Tandem (CT)	192" 4 877 mm
After Frame (AF)	114" 2 896 mm
Frame Section Modulus	15.9 in ³ 110,000 psi 758 422 kPa
Frame Section Modulus for 360° Rotation (Minimum)*	25.0 in ³ 110,000 psi 758 422 kPa
Front Axle Gross Weight Rating	16,000 lb 7 257 kg
Rear Axle Gross Weight Rating	34,000 lb 15 422 kg
Minimum Truck Axle Weight - Front**	8,000 lb 3 629 kg
Minimum Truck Axle Weight - Back**	8,000 lb 3 629 kg
Nominal Frame Width	34"-35" 864 - 889 mm

*Also applies to front frame extensions for single front stabilizer.
**Minimum chassis weight is required to meet 85% stability requirements. Chassis data is general-not for engineering. Some dimensions depend on truck selection.

MAXIMUM TIP HEIGHT (A)	26101C
Configuration	Boom 101' 5" 30,9 m
Extended Boom	112' 8" 34,3 m
Fixed Jib	141' 10" 43,2 m

WEIGHTS	26101C
Total Crane	18,970 lb 8 605 kg
29' (8,84 m) Fixed Length Jib	630 lb 286 kg
22' (6,71 m) Flat Bed	2,000 lb 907 kg

