

Load Rating Chart

Model 50110S



© Manitex 2000

NOTE: Additional copies of this Load Rating Chart can be purchased from your Manitex Distributor. When ordering, use the part number shown in the bottom left corner of this page.

LMI OPERATING CODES

CODE	CRANE CONFIGURATION	OUTRIGGER CONFIGURATION	AREA OF OPERATION
#1	MAIN BOOM	FULLY EXTENDED	OVER REAR
#3	MAIN BOOM	FULLY EXTENDED	FULL 360°
#4	MAIN BOOM	MID POSITION	FULL 360°
#5	MAIN BOOM	RETRACTED	FULL 360°
#6	MAIN BOOM	ON TIRES	DIRECTLY OVER REAR
#7	RETRACTED JIB 0° OFFSET	FULLY EXTENDED	OVER REAR
#8	RETRACTED JIB 0° OFFSET	FULLY EXTENDED	FULL 360°
#9	RETRACTED JIB 15° OFFSET	FULLY EXTENDED	OVER REAR
#10	RETRACTED JIB 15° OFFSET	FULLY EXTENDED	FULL 360°
#11	RETRACTED JIB 30° OFFSET	FULLY EXTENDED	OVER REAR
#12	RETRACTED JIB 30° OFFSET	FULLY EXTENDED	FULL 360°
#13	EXTENDED JIB 0° OFFSET	FULLY EXTENDED	OVER REAR
#14	EXTENDED JIB 0° OFFSET	FULLY EXTENDED	FULL 360°
#15	EXTENDED JIB 15° OFFSET	FULLY EXTENDED	OVER REAR
#16	EXTENDED JIB 15° OFFSET	FULLY EXTENDED	FULL 360°
#17	EXTENDED JIB 30° OFFSET	FULLY EXTENDED	OVER REAR
#18	EXTENDED JIB 30° OFFSET	FULLY EXTENDED	FULL 360°
#19	RETRACTED JIB 0° OFFSET	MID POSITION	FULL 360°
#20	RETRACTED JIB 15° OFFSET	MID POSITION	FULL 360°
#21	RETRACTED JIB 30° OFFSET	MID POSITION	FULL 360°
#22	EXTENDED JIB 0° OFFSET	MID POSITION	FULL 360°
#23	EXTENDED JIB 15° OFFSET	MID POSITION	FULL 360°
#24	EXTENDED JIB 30° OFFSET	MID POSITION	FULL 360°
#25	PERSONNEL LIFTING MAIN BOOM	FULLY EXTENDED	FULL 360°
#26	PERSONNEL LIFTING RETR JIB 0° OFFSET	FULLY EXTENDED	FULL 360°
#27	PERSONNEL LIFTING RETR JIB 15° OFFSET	FULLY EXTENDED	FULL 360°
#28	PERSONNEL LIFTING RETR JIB 30° OFFSET	FULLY EXTENDED	FULL 360°
#29	PERSONNEL LIFTING EXTENDED JIB 0° OFFSET	FULLY EXTENDED	FULL 360°
#30	PERSONNEL LIFTING EXTENDED JIB 15° OFFSET	FULLY EXTENDED	FULL 360°
#31	PERSONNEL LIFTING EXTENDED JIB 30° OFFSET	FULLY EXTENDED	FULL 360°

WARNING

1. THE OPERATOR MUST READ AND UNDERSTAND THE OWNER'S MANUAL BEFORE OPERATING THIS CRANE.

2. POSITIONING OR OPERATION OF CRANE BEYOND AREAS SHOWN ON THIS CHART IS NOT INTENDED OR APPROVED EXCEPT WHERE SPECIFIED IN OWNER'S MANUAL.

3. LOADED BOOM ANGLES AT SPECIFIED BOOM LENGTHS GIVE ONLY AN APPROXIMATION OF THE OPERATING RADIUS. THE BOOM ANGLE BEFORE LOADING SHOULD BE GREATER TO ACCOUNT FOR DEFLECTIONS. DO NOT EXCEED THE OPERATING RADIUS FOR RATED LOADS.

4. THE OPERATING RADIUS SHOWN IN THE JIB RATING CHART IS FOR FULLY EXTENDED BOOM ONLY. WHEN BOOM IS NOT FULLY EXTENDED, USE ONLY LOADED BOOM ANGLE TO DETERMINE LOAD RATING OF JIB.

5. FOR BOOM ANGLES NOT SHOWN ON JIB LOAD RATING CHART, USE RATING OF NEXT LOWER BOOM ANGLE.

WARNING (CONTINUED)

6. FOR BOOM LENGTHS NOT SHOWN, USE RATING OF NEXT SHORTER OR LONGER BOOM LENGTH, WHICHEVER IS LESS. FOR RADII NOT SHOWN, USE RATING OF NEXT LONGER RADIUS.
7. CRANE LOAD RATINGS ON OUTRIGGERS ARE BASED ON FREELY SUSPENDED LOADS WITH THE MACHINE LEVELED AND STANDING ON A FIRM UNIFORM SUPPORTING SURFACE. NO ATTEMPT SHALL BE MADE TO MOVE A LOAD HORIZONTALLY ON THE GROUND IN ANY DIRECTION.
8. PRACTICAL WORKING LOADS DEPEND ON SUPPORTING SURFACE, WIND, AND OTHER FACTORS AFFECTING STABILITY SUCH AS HAZARDOUS SURROUNDINGS, EXPERIENCE OF PERSONNEL, AND PROPER HANDLING, ALL OF WHICH MUST BE TAKEN INTO ACCOUNT BY THE OPERATOR.
9. THE MAXIMUM LOAD WHICH MAY BE TELESCOPED IS LIMITED BY HYDRAULIC PRESSURE, BOOM ANGLE, AND BOOM LUBRICATION. IT IS SAFE TO ATTEMPT TO TELESCOPE ANY LOAD WITHIN THE LIMITS OF THE LOAD RATING CHART.

INFORMATION

1. DEDUCTIONS MUST BE MADE FROM RATED LOADS FOR STOWED JIB, OPTIONAL ATTACHMENTS, HOOKS, AND LOADBLOCKS (SEE DEDUCTION CHART). WEIGHTS OF SLINGS AND ALL OTHER LOAD HANDLING DEVICES SHALL BE CONSIDERED A PART OF THE LOAD.
2. LOAD RATINGS ABOVE THE HEAVY LINE ARE STRUCTURALLY LIMITED CAPACITIES. LOAD RATINGS BELOW THE HEAVY LINE ARE STABILITY LIMITED CAPACITIES AND DO NOT EXCEED 85% OF TIPPING.

DEFINITIONS

1. OPERATING RADIUS IS THE HORIZONTAL DISTANCE FROM THE AXIS OF ROTATION TO THE CENTER OF THE VERTICAL HOIST LINE OR TACKLE WITH LOAD APPLIED.
2. LOADED BOOM ANGLE IS THE INCLUDED ANGLE BETWEEN THE HORIZONTAL AND LONGITUDINAL AXES OF THE BOOM BASE AFTER LIFTING RATED LOAD AT RATED RADIUS.

ALLOWABLE LINE PULL

WARNING

1 PART LINE	2 PART LINE	3 PART LINE	4 PART LINE	5 PART LINE	6 PART LINE	7 PART LINE	8 PART LINE	9 PART LINE	10 PART LINE	
										<p>ANTI-TWO-BLOCK SYSTEM MUST BE IN GOOD OPERATING CONDITION BEFORE OPERATING CRANE.</p> <p>REFER TO THE OWNER'S MANUAL.</p> <p>KEEP AT LEAST 3 WRAPS OF LOAD LINE ON THE DRUM AT ALL TIMES.</p>
4,53 t	9,07 t	13,60 t	18,14 t	22,68 t	27,21 t	31,75 t	36,28 t	40,82 t	45,35 t	<p>15,9 mm 6 X 19 CLASS (3.5:1 SF) 15875,73 Kg MIN BREAKING STRENGTH</p> <p>15,9 mm ROT RESISTANT (5:1 SF) 22679,61 Kg MIN BREAKING STRENGTH</p>

AREA OF OPERATIONS

ON TIRES

WHEN LIFTING ON TIRES, THE BOOM MUST BE CENTERED OVER THE REAR OF THE CRANE WITH THE SWING BRAKE AND THE HOUSELOCK ENGAGED.

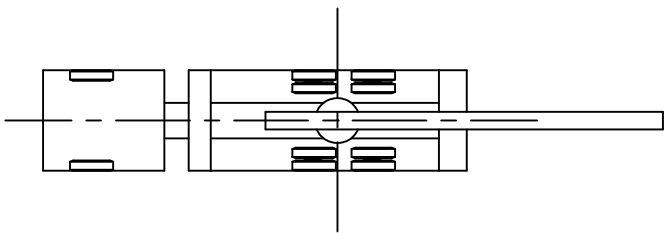

IF SUPPLIED THE FRONT BUMPER STABILIZER MUST BE SET IN ACCORDANCE TO THE OPERATORS MANUAL BEFORE WORKING IN THE "FULL 360°" AREA

IF A FRONT BUMPER STABILIZER WAS NOT SUPPLIED THEN THE FRONT TIRES MUST BE IN CONTACT WITH THE GROUND BEFORE WORKING IN THE "FULL 360°" AREA

ON OUTRIGGERS

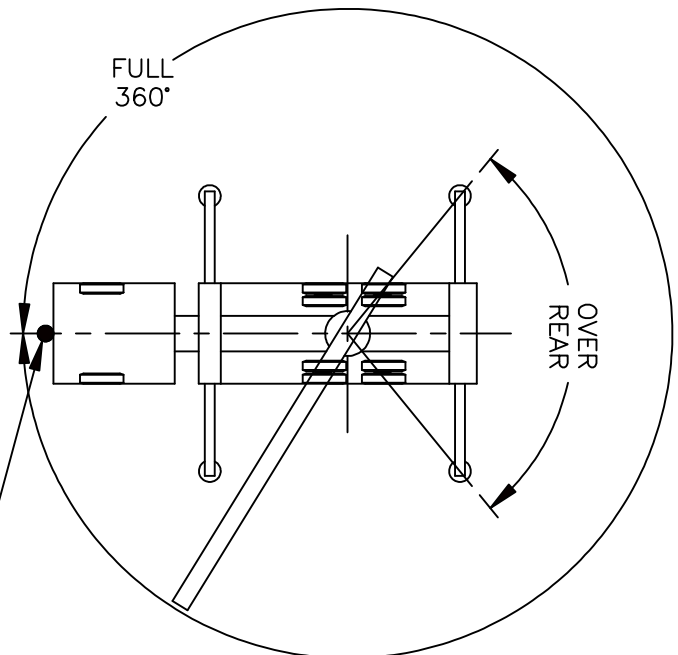

DEDUCTIONS FROM RATED LOADS FOR LOAD HANDLING DEVICES SUPPLIED BY MANITEX

AUXILIARY BLOCK	-----	22,67 Kg
ROOSTER SHEAVE	-----	31,75 Kg
LIFTING FROM MAIN BOOM WITH JIB STOWED OR ERECTED	-----	SEE LOAD CHART
OVERHAUL BALL	-----	SEE MANUFACTURER NAMEPLATE
LOAD BLOCK	-----	SEE MANUFACTURER NAMEPLATE

- RANGE DIAGRAM -

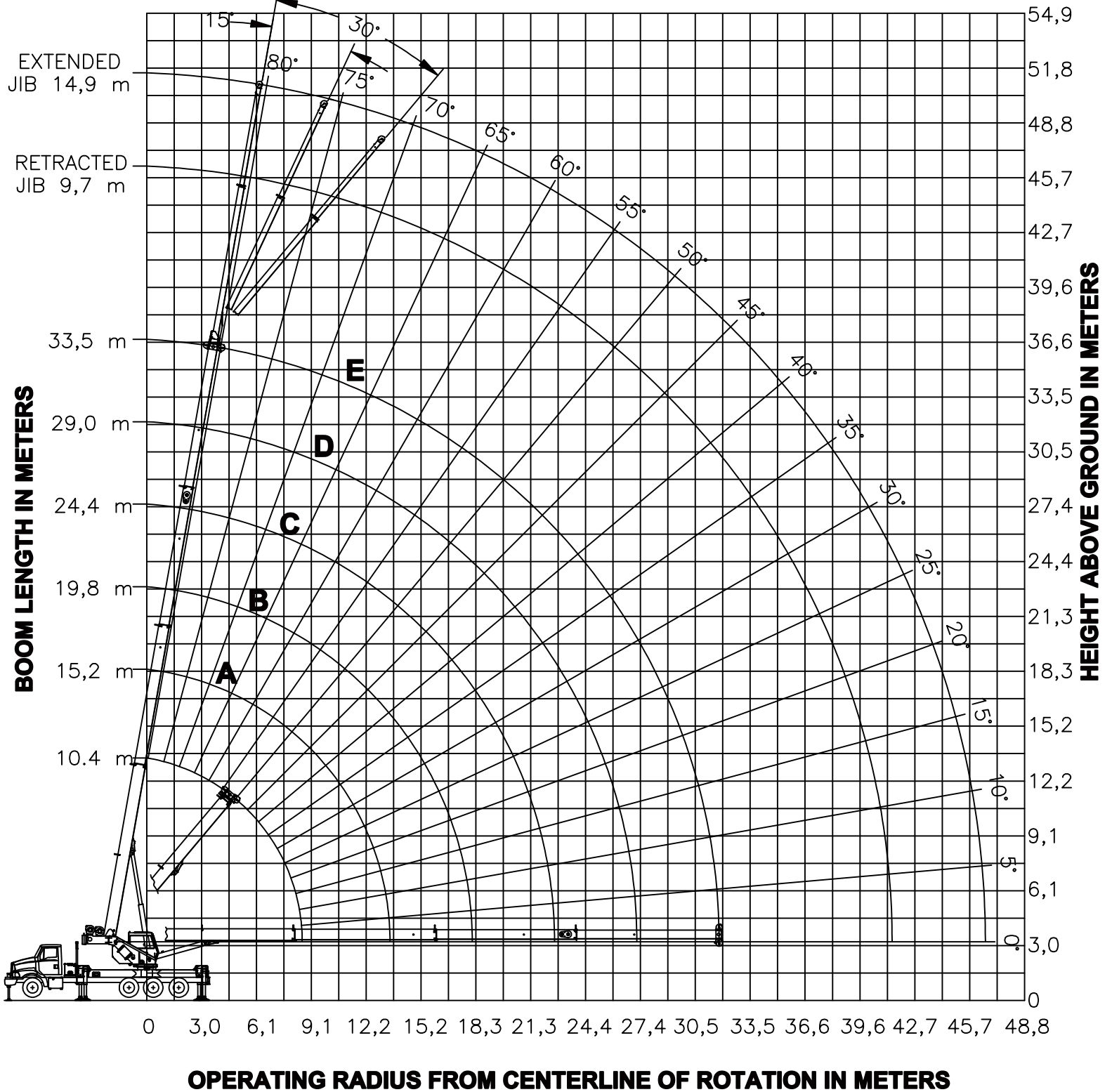

**USE THIS CHART ONLY
WHEN ALL OUTRIGGER
BEAMS ARE FULLY
EXTENDED**

PINS MUST BE
DISENGAGED FOR
THIS OUTRIGGER
CONFIGURATION

OUTRIGGER
BEAMS MUST
BE EXTENDED
TO MARK

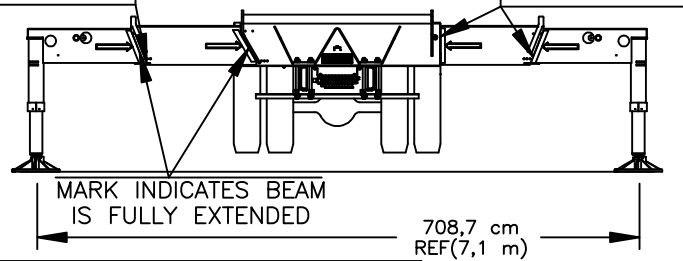

MAIN BOOM LIFTING CAPACITIES

LOAD RADIUS (m)	BOOM LENGTH 10,4 m			BOOM LENGTH 15,2 m (A)			BOOM LENGTH 19,8 m (B)		
	LOADED BOOM ANGLE (DEG)	CODE 1	CODE 3	LOADED BOOM ANGLE (DEG)	CODE 1	CODE 3	LOADED BOOM ANGLE (DEG)	CODE 1	CODE 3
		OVER REAR (t)	FULL 360° (t)		OVER REAR (t)	FULL 360° (t)		OVER REAR (t)	FULL 360° (t)
1,8	71	45,35	45,35						
2,4	67,5	40,14	40,14						
3,0	63,5	35,47	35,47	73	23,13	23,13			
3,7	60	31,84	31,84	70,5	23,13	23,13	76	18,14	18,14
4,6	53,5	27,48	27,48	67	23,13	23,13	73	18,14	18,14
6,1	42	20,91	20,91	60,5	21,13	21,13	68,5	17,60	17,60
7,6	26,5	16,23	16,23	53,5	16,60	16,60	63,5	15,03	15,03
9,1				45,5	13,44	11,67	58,5	13,15	11,92
10,7				36,5	10,47	8,65	53	10,69	8,89
12,2				25	8,31	6,69	47	8,53	6,93
13,7							40,5	6,99	5,55
15,2							32,5	5,83	4,52
16,8							22,5	4,92	3,73
All load ratings in tonnes (t)									
0,52 t			0,35 t			0,27 t			STOWED JIB
1,33 t			1,20 t			1,14 t			ERECTED JIB (RETRACTED)
1,51 t			1,32 t			1,23 t			ERECTED JIB (EXTENDED)

DEDUCTIONS FOR JIB FROM MAIN BOOM CAPACITIES

LOAD RADIUS (m)	BOOM LENGTH 24,4 m (C)			BOOM LENGTH 29,0 m (D)			BOOM LENGTH 33,5 m (E)		
	LOADED BOOM ANGLE (DEG)	CODE 1	CODE 3	LOADED BOOM ANGLE (DEG)	CODE 1	CODE 3	LOADED BOOM ANGLE (DEG)	CODE 1	CODE 3
		OVER REAR (t)	FULL 360° (t)		OVER REAR (t)	FULL 360° (t)		OVER REAR (t)	FULL 360° (t)
4,6	77	12,80	12,80						
6,1	73,5	12,80	12,80	76,5	9,07	9,07			
7,6	69,5	11,04	11,04	73,5	9,07	9,07	76,5	7,03	7,03
9,1	65,5	9,65	9,65	70,5	8,47	8,47	74	7,03	7,03
10,7	61,5	8,61	8,61	67,5	7,52	7,52	71,5	6,64	6,64
12,2	57,5	7,65	7,05	64	6,72	6,72	69	6,01	6,01
13,7	53	6,85	5,67	60,5	6,04	5,75	66	5,42	5,42
15,2	48	5,95	4,64	57	5,46	4,72	63	4,92	4,78
16,8	43	5,04	3,86	53	4,95	3,93	60	4,51	3,99
18,3	37	4,31	3,23	49	4,39	3,31	56,5	4,17	3,36
19,8	30	3,72	2,72	44,5	3,79	2,79	53,5	3,81	2,84
21,3	21	3,22	2,29	40	3,30	2,37	50	3,35	2,42
22,9				34,5	2,88	2,01	46	2,93	2,06
24,4				28	2,51	1,71	42	2,56	1,75
25,9				20	2,19	1,43	37,5	2,25	1,49
27,4							33	1,98	1,26
29,0							27	1,73	1,05
30,5							19	1,51	0,87
All load ratings in tonnes (t)									
0,22 t			0,19 t			0,16 t			STOWED JIB
1,10 t			1,07 t			1,05 t			ERECTED JIB (RETRACTED)
1,17 t			1,13 t			1,10 t			ERECTED JIB (EXTENDED)

DEDUCTIONS FOR JIB FROM MAIN BOOM CAPACITIES

**USE THIS CHART ONLY
WHEN ALL OUTRIGGER
BEAMS ARE IN THE MID
POSITION**

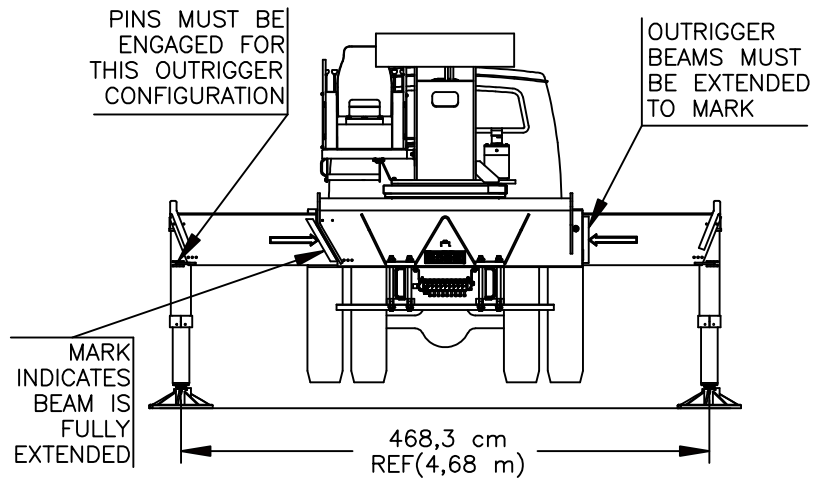

MAIN BOOM LIFTING CAPACITIES

LMI CODE 4

LOAD RADIUS (m)	BOOM LENGTH 10,4 m		BOOM LENGTH 15,2 m (A)		BOOM LENGTH 19,8 m (B)		BOOM LENGTH 24,4 m (C)		BOOM LENGTH 29,0 m (D)		BOOM LENGTH 33,5 m (E)	
	LOADED BOOM ANGLE (DEG)	FULL 360° (t)	LOADED BOOM ANGLE (DEG)	FULL 360° (t)	LOADED BOOM ANGLE (DEG)	FULL 360° (t)	LOADED BOOM ANGLE (DEG)	FULL 360° (t)	LOADED BOOM ANGLE (DEG)	FULL 360° (t)	LOADED BOOM ANGLE (DEG)	FULL 360° (t)
1,8	71	45,35										
2,4	67,5	40,14										
3,0	63,5	35,47	73	23,13								
3,7	60	31,84	70,5	23,13	76	18,14						
4,6	53,5	20,65	67	21,33	73	18,14	77	12,80				
6,1	42	11,15	60,5	11,69	68,5	11,93	73,5	12,09	76,5	9,07		
7,6	26,5	7,11	53,5	7,61	63,5	7,82	69,5	7,95	73,5	8,04	76,5	7,03
9,1			45,5	5,35	58,5	5,55	65,5	5,66	70,5	5,75	74	5,80
10,7			36,5	3,91	53	4,10	61,5	4,21	67,5	4,29	71,5	4,34
12,2			25	2,90	47	3,10	57,5	3,22	64	3,28	69	3,33
13,7					40,5	2,37	53	2,48	60,5	2,55	66	2,59
15,2					32,5	1,80	48	1,92	57	1,98	63	2,03
16,8					22,5	1,36	43	1,47	53	1,54	60	1,58
18,3							37	1,11	49	1,18	56,5	1,22
19,8							30	0,81	44,5	0,88	53,5	0,92
21,3							21	0,55	40	0,63	50	0,68
22,9									34,5	0,41	46	0,46
24,4												
	0,52 t	0,35 t	0,27 t	0,22 t	0,19 t	0,16 t	STOWED JIB					
	1,33 t	1,20 t	1,14 t	1,10 t	1,07 t	1,05 t	ERECTED JIB (RETRACTED)					
	1,51 t	1,32 t	1,23 t	1,17 t	1,13 t	1,10 t	ERECTED JIB (EXTENDED)					

DEDUCTIONS FOR JIB FROM MAIN BOOM CAPACITIES

**USE THIS CHART WHEN ALL
OUTRIGGER BEAMS ARE NOT IN
EITHER THE MID OR FULLY
EXTENDED POSITION**

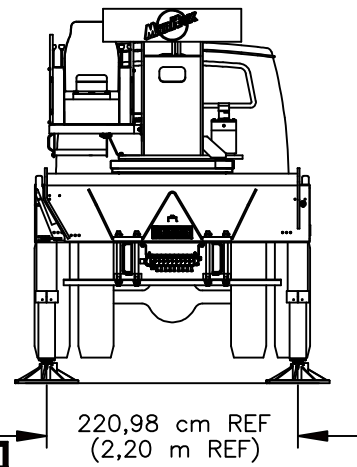

MAIN BOOM LIFTING CAPACITIES

LMI CODE 5													
LOAD RADIUS (m)	BOOM LENGTH 10,4 m		BOOM LENGTH 15,2 m (A)		BOOM LENGTH 19,8 m (B)		BOOM LENGTH 24,4 m (C)		BOOM LENGTH 29,0 m (D)		BOOM LENGTH 33,5 m (E)		DEDUCTIONS FOR JIB FROM MAIN BOOM CAPACITIES
	LOADED BOOM ANGLE (DEG)	FULL 360° (t)	LOADED BOOM ANGLE (DEG)	FULL 360° (t)	LOADED BOOM ANGLE (DEG)	FULL 360° (t)	LOADED BOOM ANGLE (DEG)	FULL 360° (t)	LOADED BOOM ANGLE (DEG)	FULL 360° (t)	LOADED BOOM ANGLE (DEG)	FULL 360° (t)	
1,8	71	38,70											
2,4	67,5	19,80											
3,0	63,5	12,75	73	13,32									All load ratings in tonnes (t)
3,7	60	9,07	70,5	9,57	76	9,81							
4,6	53,5	5,96	67	6,40	73	6,61	77	6,74					
6,1	42	3,31	60,5	3,71	68,5	3,89	73,5	4,00	76,5	4,08			
7,6	26,5	1,87	53,5	2,27	63,5	2,44	69,5	2,54	73,5	2,61	76,5	2,66	
9,1			45,5	1,37	58,5	1,53	65,5	1,63	70,5	1,70	74	1,74	
10,7			36,5	0,75	53	0,92	61,5	1,01	67,5	1,07	71,5	1,12	
12,2					47	0,47	57,5	0,56	64	0,62	69	0,67	
	0,52 t		0,35 t		0,27 t		0,22 t		0,19 t		0,16 t		STOWED JIB

WARNINGS

1. THE JIB MUST BE IN THE STOWED POSITION, IF SO EQUIPPED, WHEN USING THIS OUTRIGGER CONFIGURATION.

**USE THIS CHART
WHEN PICKING
LOADS ON TIRES**

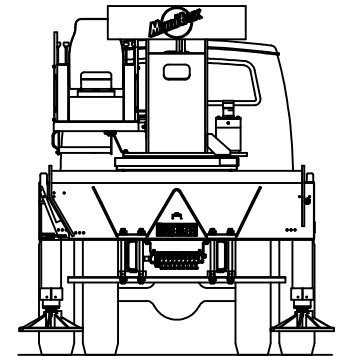

ON TIRE CAPACITIES

WARNINGS

LMI CODE 6			
LOAD RADIUS (m)	MAX BOOM LENGTH (m)	BOOM DIRECTLY OVER REAR (t)	STOWED JIB DEDUCTION (t)
3,0	10,4	4,53	0,52
3,7	10,4	4,08	0,52
4,6	10,4	3,44	0,52
6,1	10,4	2,10	0,52
7,6	10,4 (A)	1,27	0,35
9,1	10,4 (A)	0,70	0,35

1. CRANE LOAD RATINGS ON TIRES ARE BASED ON THE CRANE BEING LEVEL AND TRAVELING ON A FIRM UNIFORM SURFACE (BLACK TOP, CONCRETE OR SIMILAR SURFACE).
2. TIRES MUST BE INFLATED TO 827 kPa FOR PICKING ON TIRES. CONSULT TRUCK MANUAL FOR PROPER INFLATION PROCEDURE.
3. THE JIB MUST BE IN THE STOWED POSITION, IF SO EQUIPPED, WHEN PICKING ON TIRES.
4. WHEN LIFTING ON TIRES, THE BOOM MUST BE CENTERED OVER THE REAR OF THE CRANE WITH THE SWING BRAKE AND THE HOUSELOCK ENGAGED.
5. KEEP THE LOAD CLOSE TO THE GROUND AND RESTRAINED FROM SWINGING.
6. WHEN THE RADIUS IS BETWEEN LISTED VALUES, USE THE SMALLER OF THE TWO LOAD RATINGS.
7. DO NOT OPERATE AT LONGER RADII THAN THOSE LISTED ON THE LOAD CHART.

All load ratings in tonnes (t)

**USE THIS CHART ONLY
WHEN ALL OUTRIGGER
BEAMS ARE FULLY
EXTENDED**

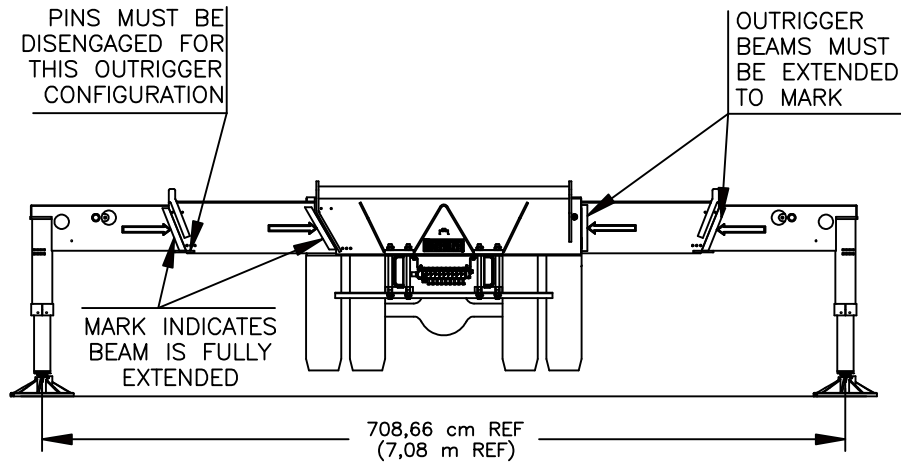

9,7 m RETRACTED JIB LIFTING CAPACITIES

LOAD RADIUS (m)	LOADED BOOM ANGLE (DEG)	0° OFFSET		15° OFFSET			30° OFFSET		
		CODE 7 OVER REAR (t)	CODE 8 FULL 360° (t)	LOADED BOOM ANGLE (DEG)	CODE 9 OVER REAR (t)	CODE 10 FULL 360° (t)	LOADED BOOM ANGLE (DEG)	CODE 11 OVER REAR (t)	CODE 12 FULL 360° (t)
10,7	76,5	3,31	3,31						
12,2	74,5	3,31	3,31						
13,7	72,5	3,31	3,31	76	2,94	2,94			
15,2	70,5	3,31	3,31	73,5	2,94	2,94	76	2,63	2,63
16,8	68,5	3,16	3,16	71,5	2,94	2,94	74	2,63	2,63
18,3	66,5	2,99	2,99	69,5	2,77	2,77	72	2,60	2,60
19,8	64	2,82	2,82	67	2,62	2,62	69,5	2,47	2,47
21,3	62	2,66	2,41	65	2,47	2,47	67	2,34	2,34
22,9	59,5	2,50	2,05	62,5	2,34	2,23	64,5	2,22	2,22
24,4	57	2,31	1,73	60	2,21	1,90	62	2,11	2,04
25,9	54,5	2,12	1,46	57,5	2,10	1,61	59,5	2,01	1,73
27,4	52	1,93	1,23	54,5	1,99	1,36	56,5	1,92	1,47
29,0	49	1,69	1,02	51,5	1,80	1,14	53,5	1,84	1,23
30,5	46	1,47	0,84	48,5	1,57	0,94	50,5	1,65	1,02
32,0	43	1,27	0,67	45,5	1,36	0,77	47	1,43	0,83
33,5	39,5	1,10	0,53	42	1,18	0,61	43,5	1,23	0,66
35,1	35,5	0,94	0,39	38	1,01	0,46	39	1,05	0,50
36,6	31,5	0,80		34	0,85		34,5	0,88	0,35
38,1	26,5	0,66		29	0,71		29	0,72	
39,6	20,5	0,54		22	0,57		20	0,56	
41,1	10	0,43							
42,7									

All load ratings in tonnes (t)

**USE THIS CHART ONLY
WHEN ALL OUTRIGGER
BEAMS ARE FULLY
EXTENDED**

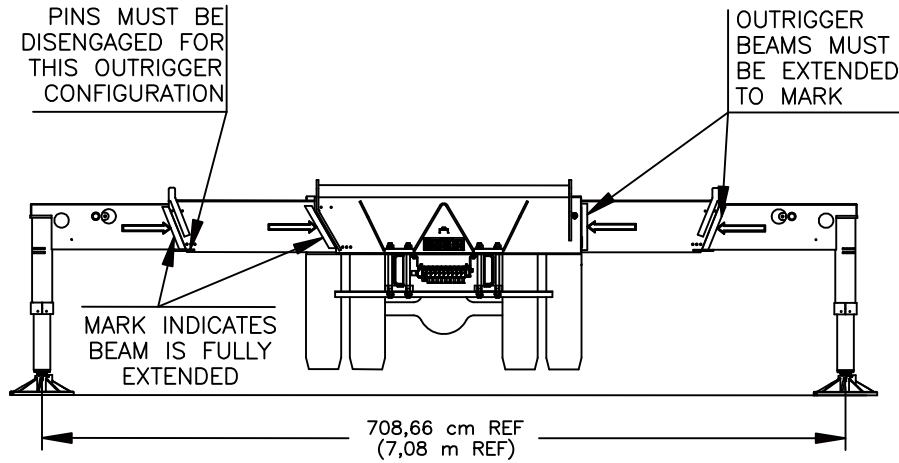

14,9 m EXTENDED JIB LIFTING CAPACITIES

LOAD RADIUS (m)	LOADED BOOM ANGLE (DEG)	0° OFFSET		15° OFFSET			30° OFFSET		
		CODE 13	CODE 14	LOADED BOOM ANGLE (DEG)	CODE 15	CODE 16	LOADED BOOM ANGLE (DEG)	CODE 17	CODE 18
		OVER REAR (t)	FULL 360° (t)		OVER REAR (t)	FULL 360° (t)		OVER REAR (t)	FULL 360° (t)
12,2	77	2,44	2,44						
13,7	75	2,44	2,44						
15,2	73,5	2,44	2,44	77	2,13	2,13			
16,8	71,5	2,44	2,44	75	2,13	2,13			
18,3	69,5	2,44	2,44	73,5	2,03	2,03	77	1,59	1,59
19,8	68	2,37	2,37	71,5	1,94	1,94	75	1,59	1,59
21,3	66	2,23	2,23	69,5	1,85	1,85	73,5	1,54	1,54
22,9	64	2,11	2,11	67,5	1,78	1,78	71	1,50	1,50
24,4	62	2,00	2,00	65,5	1,71	1,71	69	1,45	1,45
25,9	60	1,89	1,74	63,5	1,65	1,65	67	1,41	1,41
27,4	57,5	1,79	1,50	61,5	1,59	1,59	64,5	1,38	1,38
29,0	55,5	1,70	1,29	59	1,54	1,48	62	1,35	1,35
30,5	53	1,61	1,10	57	1,49	1,28	59,5	1,32	1,32
32,0	50,5	1,53	0,94	54,5	1,44	1,09	57	1,29	1,22
33,5	48	1,36	0,79	52	1,38	0,93	54,5	1,27	1,04
35,1	45,5	1,20	0,65	49	1,32	0,78	51,5	1,25	0,88
36,6	42,5	1,05	0,53	46	1,16	0,64	48,5	1,23	0,73
38,1	39,5	0,92	0,42	43	1,02	0,52	45	1,08	0,58
39,6	36	0,79		39,5	0,88	0,40	41	0,93	0,45
41,1	32	0,68		35,5	0,75		36,5	0,79	
42,7	28	0,58		31	0,63		31	0,65	
44,2	22,5	0,48		25	0,52				
45,7	15	0,39		15,5	0,40				
47,2									

All load ratings in tonnes (t)

**USE THIS CHART ONLY
WHEN ALL OUTRIGGER
BEAMS ARE IN THE MID
POSITION**

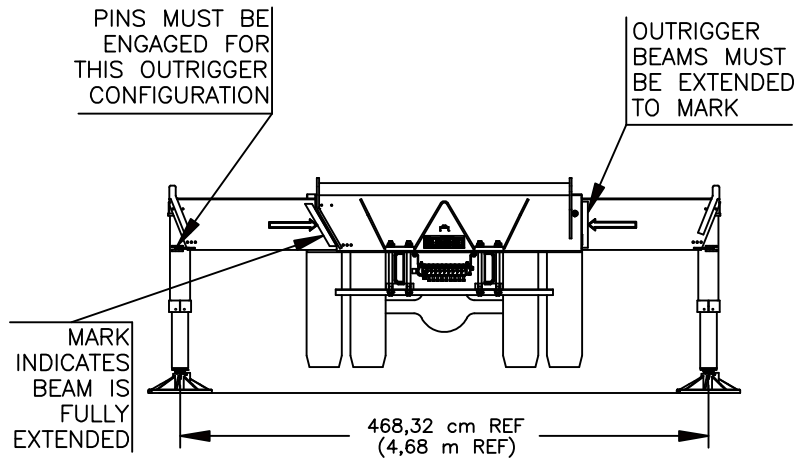

9,7 m RETRACTED JIB LIFTING CAPACITIES

LOAD RADIUS (m)	0° OFFSET		15° OFFSET		30° OFFSET	
	LOADED BOOM ANGLE (DEG)	CODE 19	LOADED BOOM ANGLE (DEG)	CODE 20	LOADED BOOM ANGLE (DEG)	CODE 21
		FULL 360° (t)		FULL 360° (t)		FULL 360° (t)
10,7	76,5	3,31				
12,2	74,5	3,31				
13,7	72,5	2,57	76	2,92		
15,2	70,5	2,00	73,5	2,29	76	2,56
16,8	68,5	1,54	71,5	1,80	74	2,03
18,3	66,5	1,17	69,5	1,41	72	1,61
19,8	64	0,87	67	1,07	69,5	1,25
21,3	62	0,61	65	0,80	67	0,95
22,9	59,5	0,39	62,5	0,56	64,5	0,69
24,4			60	0,35	62	0,48

All load ratings in tonnes (t)

14,9 m EXTENDED JIB LIFTING CAPACITIES

LOAD RADIUS (m)	0° OFFSET		15° OFFSET		30° OFFSET	
	LOADED BOOM ANGLE (DEG)	CODE 22	LOADED BOOM ANGLE (DEG)	CODE 23	LOADED BOOM ANGLE (DEG)	CODE 24
		FULL 360° (t)		FULL 360° (t)		FULL 360° (t)
12,2	77	2,44				
13,7	75	2,44				
15,2	73,5	2,29	77	2,13		
16,8	71,5	1,83	75	2,13		
18,3	69,5	1,46	73,5	1,80	77	1,59
19,8	68	1,15	71,5	1,46	75	1,59
21,3	66	0,89	69,5	1,17	73,5	1,41
22,9	64	0,67	67,5	0,92	71	1,14
24,4	62	0,48	65,5	0,70	69	0,90
25,9			63,5	0,52	67	0,69
27,4			61,5	0,35	64,5	0,51
29,0					62	0,35

All load ratings in tonnes (t)