

# Load Rating Chart

## *Model 50155S*



© Manitex 2000

**NOTE:** Additional copies of this Load Rating Chart can be purchased from your Manitex Distributor. When ordering, use the part number shown in the bottom left corner of this page.

## LMI OPERATING CODES

<u>CODE</u>	<u>CRANE CONFIGURATION</u>	<u>OUTRIGGER CONFIGURATION</u>	<u>AREA OF OPERATION</u>
#1	— MAIN BOOM — — — — —	FULLY EXTENDED — — — — —	OVER REAR
#3	— MAIN BOOM — — — — —	FULLY EXTENDED — — — — —	FULL 360°
#4	— MAIN BOOM — — — — —	MID POSITION — — — — —	FULL 360°
#7	— FIXED JIB 0° OFFSET — — — — —	FULLY EXTENDED — — — — —	OVER REAR
#8	— FIXED JIB 0° OFFSET — — — — —	FULLY EXTENDED — — — — —	FULL 360°
#9	— FIXED JIB 15° OFFSET — — — — —	FULLY EXTENDED — — — — —	OVER REAR
#10	— FIXED JIB 15° OFFSET — — — — —	FULLY EXTENDED — — — — —	FULL 360°
#11	— FIXED JIB 30° OFFSET — — — — —	FULLY EXTENDED — — — — —	OVER REAR
#12	— FIXED JIB 30° OFFSET — — — — —	FULLY EXTENDED — — — — —	FULL 360°
#25	— PERSONNEL LIFTING MAIN BOOM — — — — —	FULLY EXTENDED — — — — —	FULL 360°
#26	— PERSONNEL LIFTING FIXED JIB 0° OFFSET — — — — —	FULLY EXTENDED — — — — —	FULL 360°
#27	— PERSONNEL LIFTING FIXED JIB 15° OFFSET — — — — —	FULLY EXTENDED — — — — —	FULL 360°
#28	— PERSONNEL LIFTING FIXED JIB 30° OFFSET — — — — —	FULLY EXTENDED — — — — —	FULL 360°

### **WARNING**

1. THE OPERATOR MUST READ AND UNDERSTAND THE OWNER'S MANUAL BEFORE OPERATING THIS CRANE.
  
2. POSITIONING OR OPERATION OF CRANE BEYOND AREAS SHOWN ON THE LOAD CHART IS NOT INTENDED OR APPROVED EXCEPT WHERE SPECIFIED IN OWNER'S MANUAL.
  
3. LOADED BOOM ANGLES AT SPECIFIED BOOM LENGTHS GIVE ONLY AN APPROXIMATION OF THE OPERATING RADIUS. THE BOOM ANGLE BEFORE LOADING SHOULD BE GREATER TO ACCOUNT FOR DEFLECTIONS. DO NOT EXCEED THE OPERATING RADIUS FOR RATED LOADS.
  
4. THE OPERATING RADIUS SHOWN IN THE JIB RATING CHART IS FOR FULLY EXTENDED BOOM ONLY. WHEN BOOM IS NOT FULLY EXTENDED, USE ONLY LOADED BOOM ANGLE TO DETERMINE LOAD RATING OF JIB.
  
5. FOR BOOM ANGLES NOT SHOWN ON JIB LOAD RATING CHART, USE RATING OF NEXT LOWER BOOM ANGLE.

## **WARNING (CONTINUED)**

6. FOR BOOM LENGTHS NOT SHOWN, USE RATING OF NEXT SHORTER OR LONGER BOOM LENGTH, WHICHEVER IS LESS. FOR RADII NOT SHOWN, USE RATING OF NEXT LONGER RADIUS.
7. CRANE LOAD RATINGS ON OUTRIGGERS ARE BASED ON FREELY SUSPENDED LOADS WITH THE MACHINE LEVELED AND STANDING ON A FIRM UNIFORM SUPPORTING SURFACE. NO ATTEMPT SHALL BE MADE TO MOVE A LOAD HORIZONTALLY ON THE GROUND IN ANY DIRECTION.
8. PRACTICAL WORKING LOADS DEPEND ON SUPPORTING SURFACE, WIND, AND OTHER FACTORS AFFECTING STABILITY SUCH AS HAZARDOUS SURROUNDINGS, EXPERIENCE OF PERSONNEL, AND PROPER HANDLING, ALL OF WHICH MUST BE TAKEN INTO ACCOUNT BY THE OPERATOR.
9. THE MAXIMUM LOAD WHICH MAY BE TELESCOPED IS LIMITED BY HYDRAULIC PRESSURE, BOOM ANGLE, AND BOOM LUBRICATION. IT IS SAFE TO ATTEMPT TO TELESCOPE ANY LOAD WITHIN THE LIMITS OF THE LOAD RATING CHART.
10. LIFTING OFF THE MAIN BOOM POINT WHILE THE SWING AROUND JIB IS ERECTED IS NOT INTENDED OR APPROVED.

## **INFORMATION**

1. DEDUCTIONS MUST BE MADE FROM RATED LOADS FOR STOWED JIB, OPTIONAL ATTACHMENTS, HOOKS, AND LOADBLOCKS (SEE DEDUCTION CHART). WEIGHTS OF SLINGS AND ALL OTHER LOAD HANDLING DEVICES SHALL BE CONSIDERED A PART OF THE LOAD.
2. LOAD RATINGS ABOVE THE HEAVY LINE ARE STRUCTURALLY LIMITED CAPACITIES. LOAD RATINGS BELOW THE HEAVY LINE ARE STABILITY LIMITED CAPACITIES AND DO NOT EXCEED 85% OF TIPPING.

## **DEFINITIONS**

1. OPERATING RADIUS IS THE HORIZONTAL DISTANCE FROM THE AXIS OF ROTATION TO THE CENTER OF THE VERTICAL HOIST LINE OR TACKLE WITH LOAD APPLIED.
2. LOADED BOOM ANGLE IS THE INCLUDED ANGLE BETWEEN THE HORIZONTAL AND LONGITUDINAL AXES OF THE BOOM BASE AFTER LIFTING RATED LOAD AT RATED RADIUS.

ALLOWABLE LINE PULL										<b>WARNING</b>
1 PART LINE	2 PART LINE	3 PART LINE	4 PART LINE	5 PART LINE	6 PART LINE	7 PART LINE	8 PART LINE	9 PART LINE	10 PART LINE	
										ANTI-TWO-BLOCK SYSTEM MUST BE IN GOOD OPERATING CONDITION BEFORE OPERATING CRANE.  REFER TO THE OWNER'S MANUAL.  KEEP AT LEAST 3 WRAPS OF LOAD LINE ON THE DRUM AT ALL TIMES.
10000 LBS	20000 LBS	30000 LBS	40000 LBS	50000 LBS	60000 LBS	70000 LBS	80000 LBS	90000 LBS	100000 LBS	5/8" XLT4 LOW-TORQUE (3.5:1 SF) - 35000 LBS MIN BREAKING STRENGTH

## AREA OF OPERATION

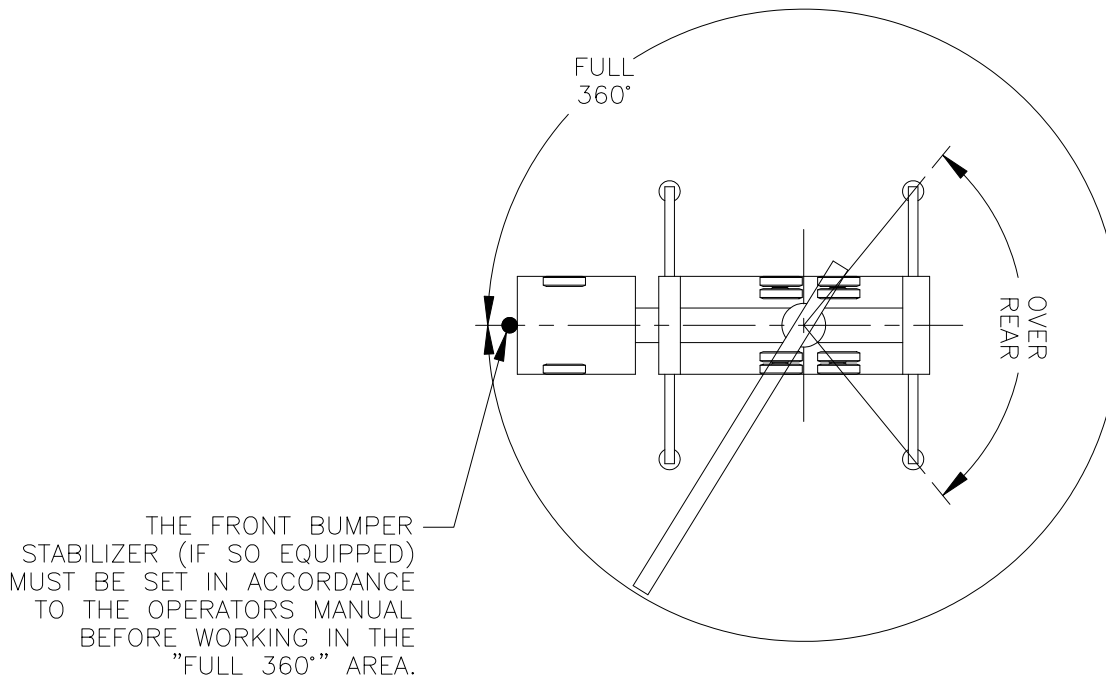

### DEDUCTIONS FROM RATED LOADS FOR LOAD HANDLING DEVICES SUPPLIED BY MANITEX

AUXILIARY BLOCK	-----	50 LBS
ROOSTER SHEAVE	-----	70 LBS
LIFTING FROM MAIN BOOM WITH JIB STOWED OR ERECTED	-----	SEE LOAD CHART
OVERHAUL BALL	-----	SEE MANUFACTURER NAMEPLATE
LOAD BLOCK	-----	SEE MANUFACTURER NAMEPLATE

# - RANGE DIAGRAM -

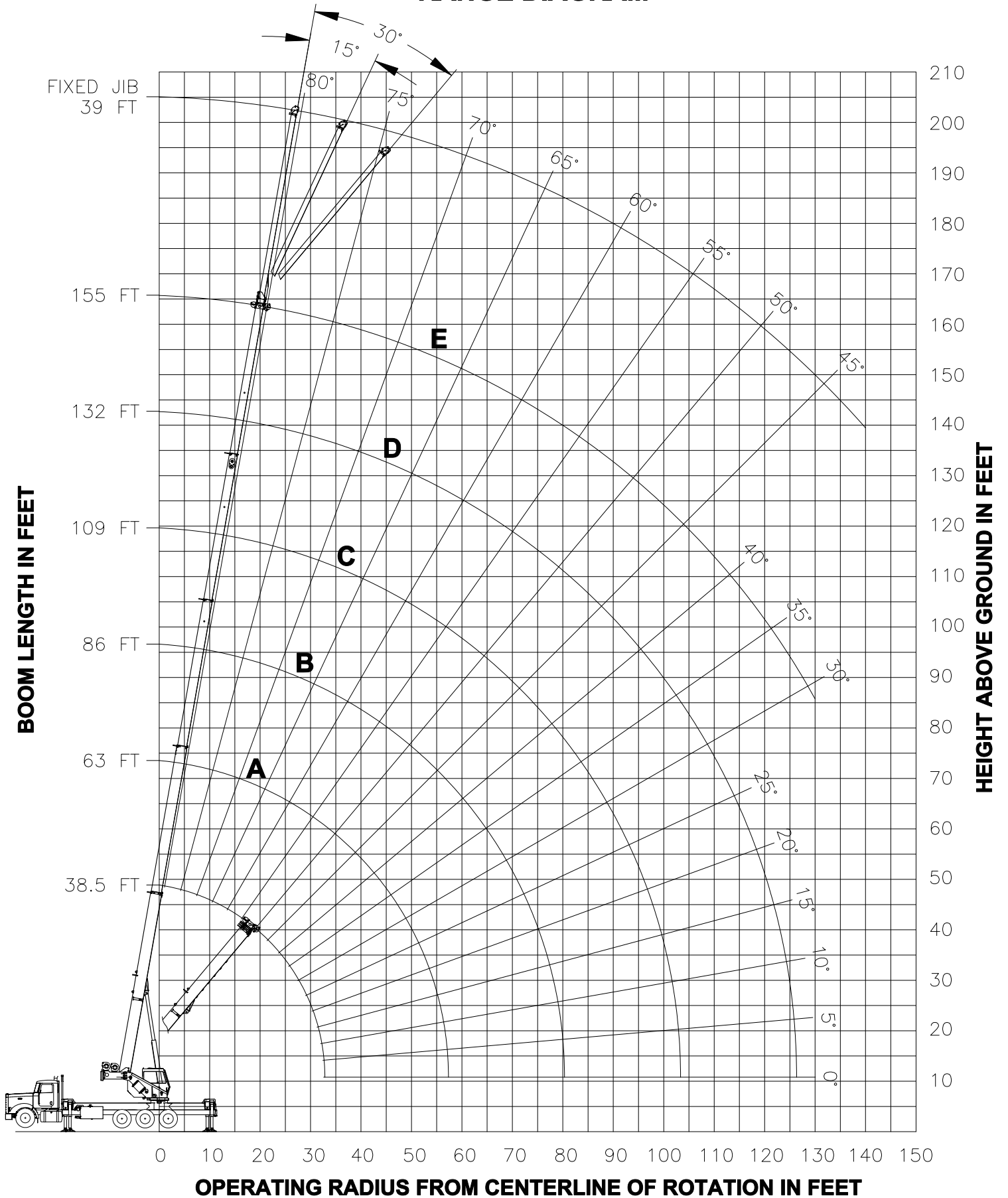

**USE THIS CHART ONLY**  
**WHEN ALL OUTRIGGER**  
**BEAMS ARE FULLY**  
**EXTENDED**

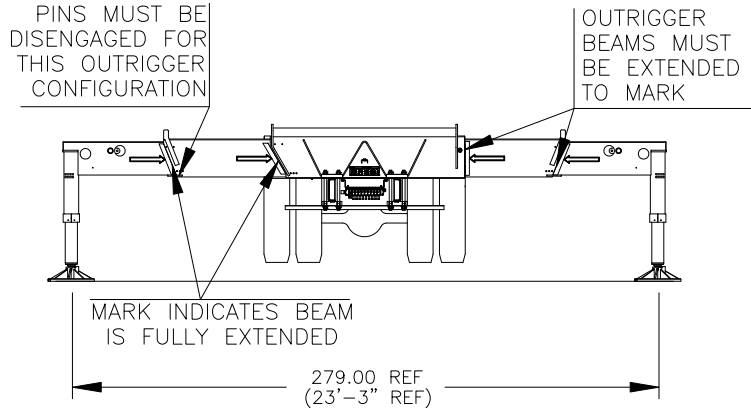

**MAIN BOOM LIFTING CAPACITIES**

LOAD RADIUS (FT)	BOOM LENGTH 38.5 FT			BOOM LENGTH 63 FT (A)			BOOM LENGTH 86 FT (B)			
	LOADED BOOM ANGLE (DEG)	CODE 1	CODE 3	LOADED BOOM ANGLE (DEG)	CODE 1	CODE 3	LOADED BOOM ANGLE (DEG)	CODE 1	CODE 3	
		OVER REAR (LBS)	FULL 360° (LBS)		OVER REAR (LBS)	FULL 360° (LBS)		OVER REAR (LBS)	FULL 360° (LBS)	
6	73.5	100000	100000							
8	70.5	85400	85400							
10	67	75100	75100	77	40000	40000				
12	64	67100	67100	75	40000	40000				
15	58.5	57700	57700	72.5	40000	40000	78.5	31000	31000	
20	49	46070	46070	67.5	38250	38250	75	28200	28200	
25	38	35280	35280	62.5	35040	35040	71.5	25970	25970	
30	22.5	27920	27490	57	29140	29140	68	23950	23950	
35				51.5	23890	21500	64	22080	22080	
40				45	19920	16460	60.5	20350	17010	
45				38	16810	12920	56.5	17250	13460	
50				29.5	14290	10280	52	14760	10820	
55				17	12200	8210	47.5	12710	8790	
60							42.5	11000	7180	
65							37	9540	5860	
70							30.5	8280	4760	
75							22.5	7170	3830	
80							7.5	4370	2990	
85										
		960 LBS			590 LBS			430 LBS		DEDUCTIONS FOR JIB FROM MAIN BOOM CAPACITIES
		2620 LBS			2270 LBS			2130 LBS		STOWED JIB
										ERECTED JIB

**USE THIS CHART ONLY**  
**WHEN ALL OUTRIGGER**  
**BEAMS ARE FULLY**  
**EXTENDED**

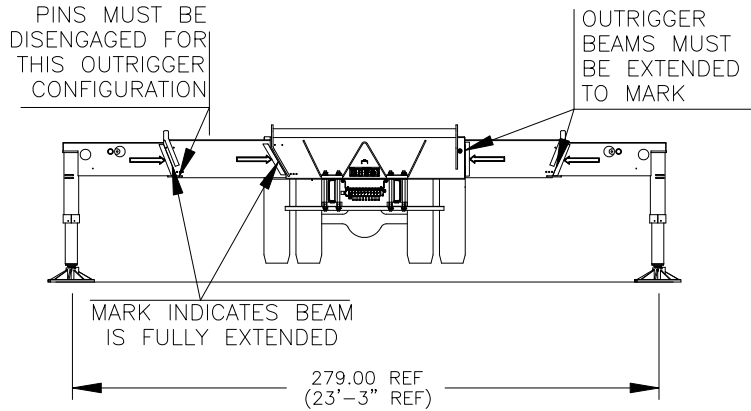

**MAIN BOOM LIFTING CAPACITIES**

LOAD RADIUS (FT)	BOOM LENGTH 109 FT (C)			BOOM LENGTH 132 FT (D)			BOOM LENGTH 155 FT (E)		
	LOADED BOOM ANGLE (DEG)	CODE 1	CODE 3	LOADED BOOM ANGLE (DEG)	CODE 1	CODE 3	LOADED BOOM ANGLE (DEG)	CODE 1	CODE 3
		OVER REAR (LBS)	FULL 360° (LBS)		OVER REAR (LBS)	FULL 360° (LBS)		OVER REAR (LBS)	FULL 360° (LBS)
25	77	18000	18000						
30	74	17000	17000	78	13500	13500			
35	71.5	15920	15920	76	12900	12900	79	9000	9000
40	68.5	14700	14700	74	12000	12000	77	9000	9000
45	65.5	13570	13570	71.5	11300	11300	75.5	9000	9000
50	62.5	12540	11100	69	10550	10550	73.5	8800	8800
55	59.5	11580	9060	67	9610	9220	71.5	8320	8320
60	56	10690	7450	64.5	9000	7600	69.5	7820	7700
65	53	9780	6130	62	8430	6280	67.5	7340	6380
70	49	8530	5040	59	7880	5190	65.5	6880	5290
75	45.5	7440	4120	56.5	7390	4270	63.5	6410	4360
80	41.5	6490	3330	53.5	6630	3480	61.5	5980	3570
85	37	5650	2640	50.5	5790	2800	59	5560	2890
90	32	4890	2040	47.5	5040	2200	57	5130	2300
95	25.5	4210	1510	44.5	4370	1680	54.5	4460	1770
100	17	3590	1030	41	3770	1210	52	3850	1310
105				37	3220		49.5	3310	890
110				33	2720		47	2810	
115				28	2260		44	2360	
120				22	1830		41	1940	
125				12	860		37.5	1550	
130							34	1190	
135									
		340 LBS			280 LBS			240 LBS	STOWED JIB
		2050 LBS			1990 LBS			1950 LBS	ERECTED JIB

DEDUCTIONS FOR JIB FROM MAIN BOOM CAPACITIES

**USE THIS CHART ONLY  
WHEN ALL OUTRIGGER  
BEAMS ARE IN THE MID  
POSITION**

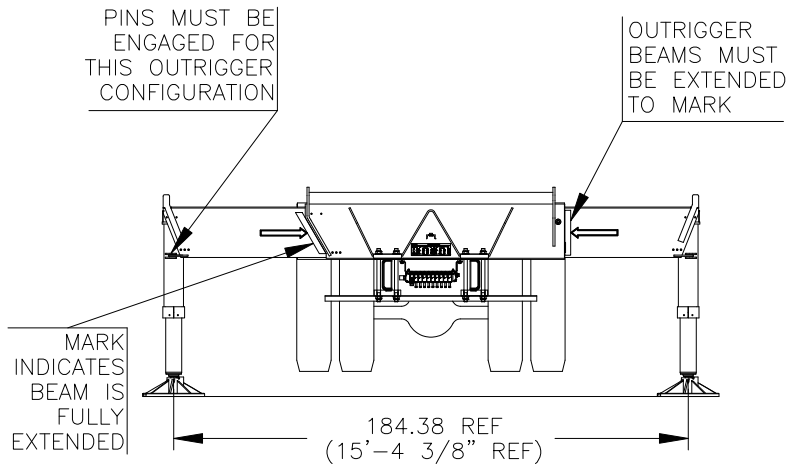

**MAIN BOOM LIFTING CAPACITIES**

LMI CODE 4													
LOAD RADIUS (FT)	BOOM LENGTH 38.5 FT		BOOM LENGTH 63 FT (A)		BOOM LENGTH 86 FT (B)		BOOM LENGTH 109 FT (C)		BOOM LENGTH 132 FT (D)		BOOM LENGTH 155 FT (E)		
	LOADED BOOM ANGLE (DEG)	FULL 360° (LBS)	LOADED BOOM ANGLE (DEG)	FULL 360° (LBS)	LOADED BOOM ANGLE (DEG)	FULL 360° (LBS)	LOADED BOOM ANGLE (DEG)	FULL 360° (LBS)	LOADED BOOM ANGLE (DEG)	FULL 360° (LBS)	LOADED BOOM ANGLE (DEG)	FULL 360° (LBS)	
6	73.5	100000											
8	70.5	85400											
10	67	75100	77	40000									
12	64	67100	75	40000									
15	58.5	52390	72.5	40000	78.5	31000							
20	49	27810	67.5	29440	75	28200							
25	38	17380	62.5	18840	71.5	19400	77	18000					
30	22.5	11540	57	12980	68	13490	74	13780	78	13500			
35			51.5	9260	64	9740	71.5	10010	76	10170	79	9000	
40			45	6680	60.5	7150	68.5	7400	74	7560	77	7660	
45			38	4780	56.5	5250	65.5	5500	71.5	5640	75.5	5740	
50			29.5	3310	52	3800	62.5	4040	69	4180	73.5	4270	
55			17	2130	47.5	2650	59.5	2890	67	3020	71.5	3110	
60					42.5	1710	56	1950	64.5	2090	69.5	2180	
65							53	1180	62	1320	67.5	1400	
70													
75													
80													
	960 LBS		590 LBS		430 LBS		340 LBS		280 LBS		240 LBS		STOWED JIB
	2620 LBS		2270 LBS		2130 LBS		2050 LBS		1990 LBS		1950 LBS		ERECTED JIB

DEDUCTIONS FOR JIB FROM MAIN BOOM CAPACITIES



**USE THIS CHART ONLY  
WHEN ALL OUTRIGGER  
BEAMS ARE FULLY  
EXTENDED**

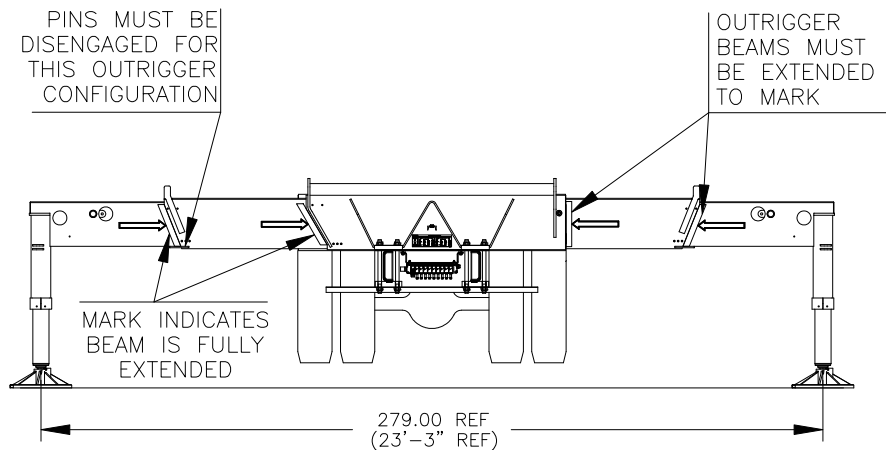

**39 FT FIXED JIB LIFTING CAPACITIES**

LOAD RADIUS (FT)	0° OFFSET			15° OFFSET			30° OFFSET		
	LOADED BOOM ANGLE (DEG)	CODE 7 OVER REAR (LBS)	CODE 8 FULL 360° (LBS)	LOADED BOOM ANGLE (DEG)	CODE 9 OVER REAR (LBS)	CODE 10 FULL 360° (LBS)	LOADED BOOM ANGLE (DEG)	CODE 11 OVER REAR (LBS)	CODE 12 FULL 360° (LBS)
40	80	4000	4000						
45	78	4000	4000						
50	77.5	4000	4000	80	4000	4000			
55	75.5	4000	4000	78	4000	4000			
60	74	4000	4000	76.5	4000	4000	80	4000	4000
65	72.5	4000	4000	75	4000	4000	78	4000	4000
70	71	4000	4000	73.5	4000	4000	76	4000	4000
75	69.5	4000	4000	72	4000	4000	74.5	3880	3880
80	68	4000	4000	71	3940	3940	73	3730	3730
85	66.5	3860	3360	69.5	3780	3780	71.5	3570	3570
90	65	3720	2750	67.5	3630	3350	70	3430	3430
95	63.5	3430	2210	66	3480	2760	68	3290	3230
100	61.5	3150	1740	64.5	3340	2250	66.5	3160	2670
105	60	2880	1310	62.5	3180	1780	65	3030	2170
110	58	2610	930	61	2880	1370	63	2920	1720
115	56	2360		59	2610	990	61	2800	1310
120	54.5	2130		57	2350		59	2570	940
125	52.5	1840		55	2110		57	2290	
130	50.5	1490		53	1830		55	2040	
135	48.5	1160		51	1480		53	1710	
140	46	860		48.5	1150		50.5	1350	
145				46.5	840		48	1020	
150									