

Load Rating Chart



Model 2592C



© Manitex

NOTE: Additional copies of this Load Rating Chart can be purchased from your Manitex Distributor. When ordering, use the part number shown in the bottom left corner of this page.

RANGE DIAGRAM - FULL SPREAD CONFIGURATION -

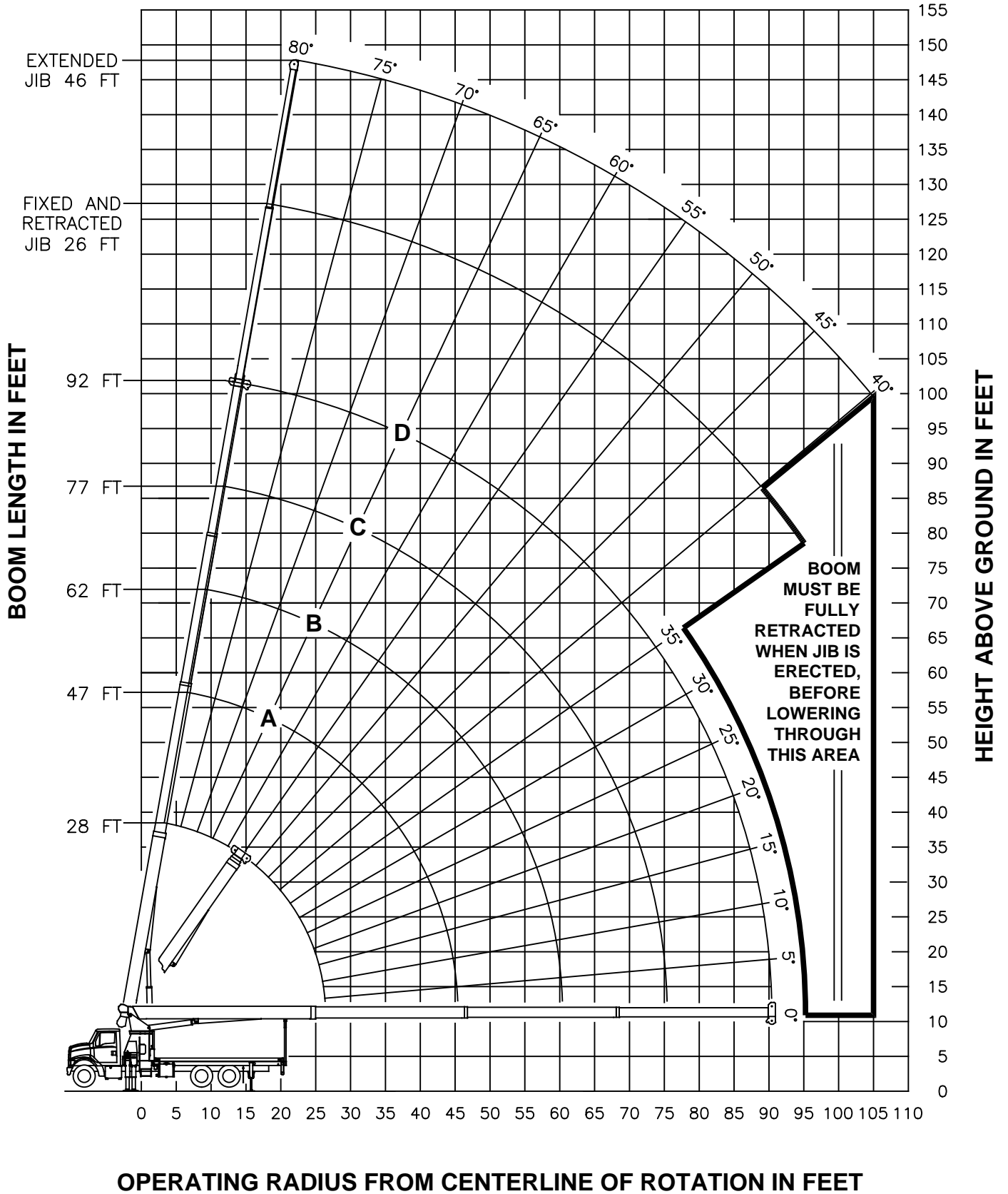

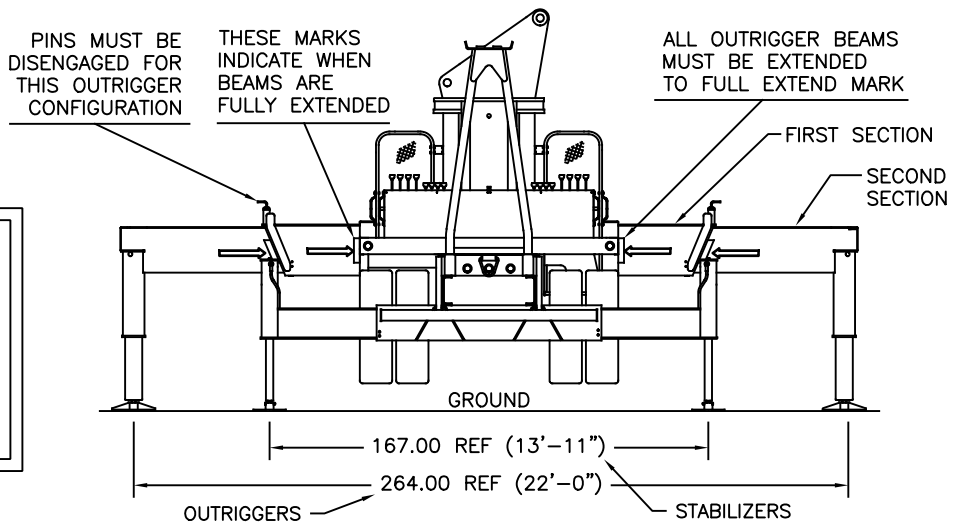

**USE THIS CHART ONLY
WHEN OUTRIGGERS
AND STABILIZERS ARE
FULLY EXTENDED**

- FULL SPREAD CONFIGURATION -

MAIN BOOM LOAD RATINGS IN LBS											JIB LOAD RATINGS IN LBS							
LMI CODE #1											FIXED JIB		TELESCOPIC JIB					
OPERATING RADIUS FT	LOADED BOOM ANGLE BOOM LENGTH AND MARKER		LMI CODE #1								OPERATING RADIUS FT	BOOM ANGLE LOADED	JIB LENGTH FOR ALL BOOM LENGTHS SEE WARNING NOTE 4	BOOM ANGLE LOADED	JIB LENGTH FOR ALL BOOM LENGTHS SEE WARNING NOTE 4	BOOM ANGLE LOADED	JIB LENGTH FOR ALL BOOM LENGTHS SEE WARNING NOTE 4	
			A		B		C		D									LMI CODE #2
	°	28 FT	°	47 FT	°	62 FT	°	77 FT	°	92 FT								°
5	79	50000									10							
8	73	40670									12							
10	69	34520	78	22500							15							
12	64	30130	76	22500	80	22500					20							
15	57	25430	72	22310	77	20960	80	15920			25	79	5600	79	5400			
20	43	20130	65	17540	72	16290	77	13540	79	10700	30	77	5300	77	5100	79	3400	
25	22	15630	58	14500	67	13340	73	11710	76	9290	35	75	4960	75	4700	77	3300	
30			50	12120	62	11290	69	10160	73	8330	40	72	4490	72	4230	76	3200	
35			41	9040	57	9200	65	8830	70	7320	45	70	4080	70	3820	74	3040	
40			30	6990	51	7150	60	7240	67	6460	50	67	3710	67	3440	72	2800	
45			11	5510	44	5700	56	5780	63	5730	55	65	3380	65	3100	69	2630	
50					36	4600	51	4690	59	4740	60	62	3080	62	2810	67	2480	
55					27	3750	46	3840	55	3890	65	59	2790	59	2500	65	2310	
60					10	3050	40	3160	51	3210	70	56	2320	56	2030	63	2110	
65							33	2610	47	2660	75	53	1930	53	1640	60	1940	
70							24	2140	42	2200	80	50	1590	50	1300	58	1760	
75							9	1730	37	1800	85	46	1300	46	1010	55	1460	
80									31	1470	90	42	1040	42	750	52	1200	
85									23	1170	95	38	810	38	520	49	970	
90									9	910	100					46	770	
95											105					43	580	
100											110							
105																		
110																		
			460 LBS	270 LBS	210 LBS	170 LBS	140 LBS	DEDUCTIONS FOR STOWED FIXED JIB										
			690 LBS	410 LBS	310 LBS	250 LBS	210 LBS	DEDUCTIONS FOR STOWED TELESCOPIC JIB										

RANGE DIAGRAM - INTERMEDIATE SPREAD CONFIGURATION - (MID EXTEND)

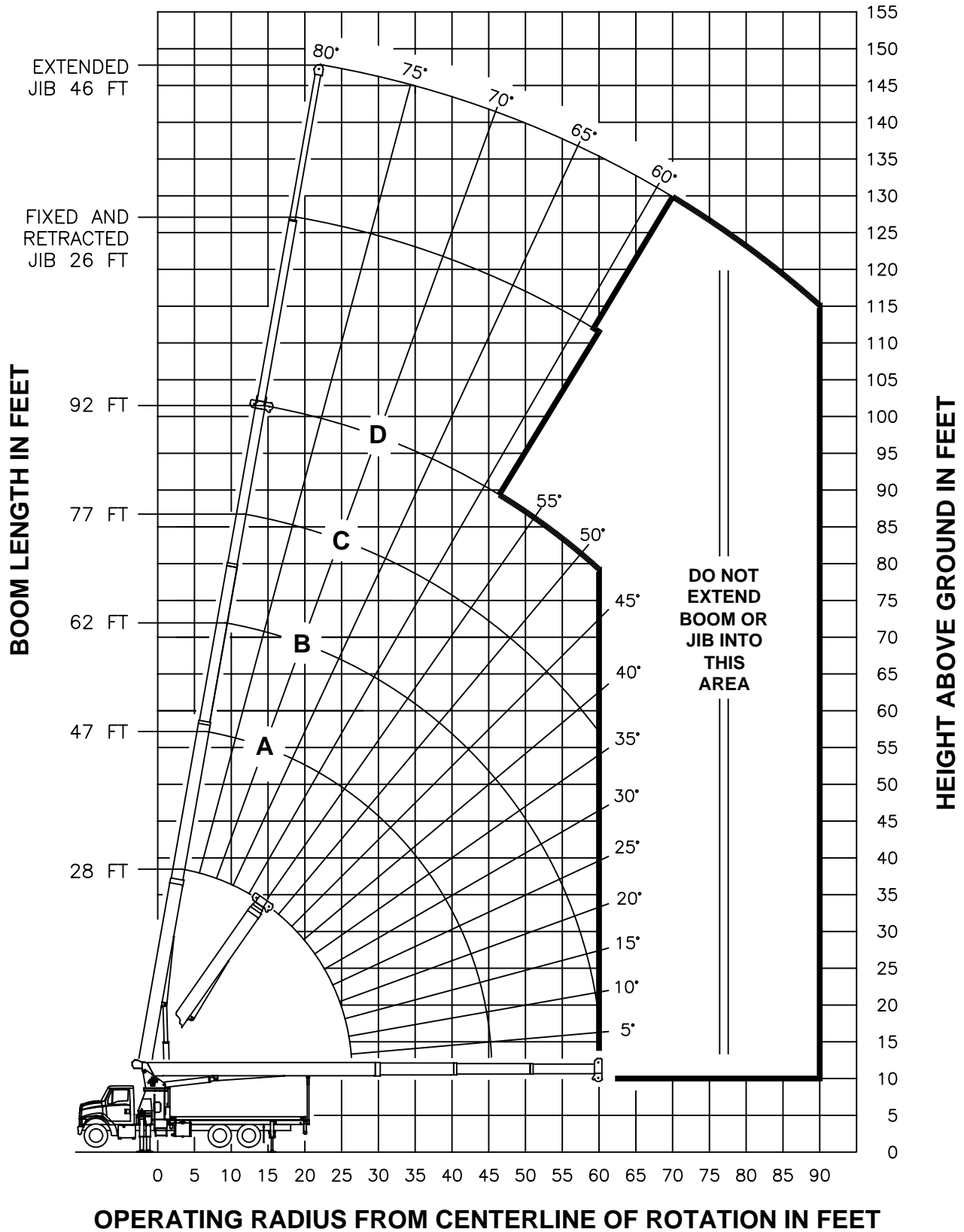

NOTE : LIFTING PERSONNEL WITH CRANE IN THIS OUTRIGGER CONFIGURATION IS STRICTLY PROHIBITED. USE ONLY FULLY EXTENDED OUTRIGGER CONFIGURATION WHEN LIFTING PERSONNEL.

**USE THIS CHART ONLY WHEN
FRONT OUTRIGGERS ARE IN THE
INTERMEDIATE POSITION AND
STABILIZERS
ARE FULLY EXTENDED**

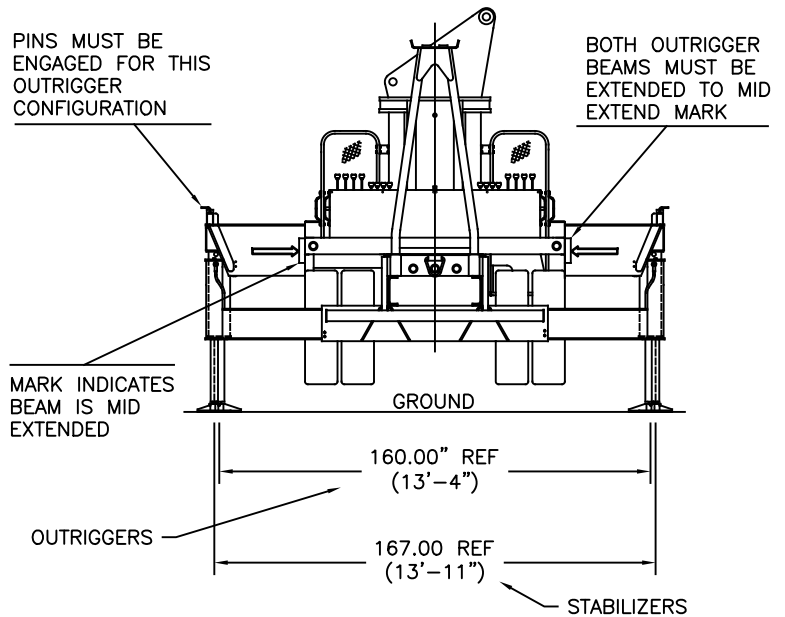

**- INTERMEDIATE SPREAD CONFIGURATION -
(MID EXTEND)**

MAIN BOOM LOAD RATINGS IN LBS										JIB LOAD RATINGS IN LBS											
LMI CODE #9										FIXED JIB		TELESCOPIC JIB									
OPERATING RADIUS FT	LOADED BOOM ANGLE BOOM LENGTH AND MARKER										LMI CODE #10		LMI CODE #11		LMI CODE #12						
			A		B		C		D		BOOM ANGLE	JIB LENGTH FOR ALL BOOM LENGTHS SEE WARNING NOTE 4	BOOM ANGLE	JIB LENGTH FOR ALL BOOM LENGTHS SEE WARNING NOTE 4	BOOM ANGLE	JIB LENGTH FOR ALL BOOM LENGTHS SEE WARNING NOTE 4					
	°	28 FT	°	47 FT	°	62 FT	°	77 FT	°	92 FT	°	26 FT	°	26 FT	°	46 FT					
5	79	50000																			
8	73	40670																			
10	69	34520	78	22500							10										
12	64	30130	76	22500	80	22500					12										
15	57	21030	72	21550	77	20960	80	15920			15										
20	43	11830	65	12290	72	12430	77	12520	79	10700	20										
25	22	7610	58	8080	67	8210	73	8290	76	8340	25	79	5600	79	5400						
30			50	5670	62	5800	69	5880	73	5920	30	77	5300	77	5100	79	3400				
35			41	4110	57	4240	65	4310	70	4360	35	75	4460	75	4160	77	3300				
40			30	3010	51	3150	60	3220	67	3260	40	72	3350	72	3050	76	3200				
45			11	2170	44	2340	56	2410	63	2450	45	70	2540	70	2230	74	2730				
50					36	1710	51	1780	59	1830	50	67	1910	67	1610	72	2090				
55					27	1210	46	1290	55	1330	55	65	1410	65	1110	69	1580				
60					10	790	40	880	51	930	60	62	1010	62	700	67	1170				
65											65	59	670			65	830				
70											70					63	540				
										460 LBS		270 LBS		210 LBS		170 LBS		140 LBS		DEDUCTIONS FOR STOWED FIXED JIB	
										690 LBS		410 LBS		310 LBS		250 LBS		210 LBS		DEDUCTIONS FOR STOWED TELESCOPIC JIB	

RANGE DIAGRAM - FULLY RETRACTED SPREAD CONFIGURATION -

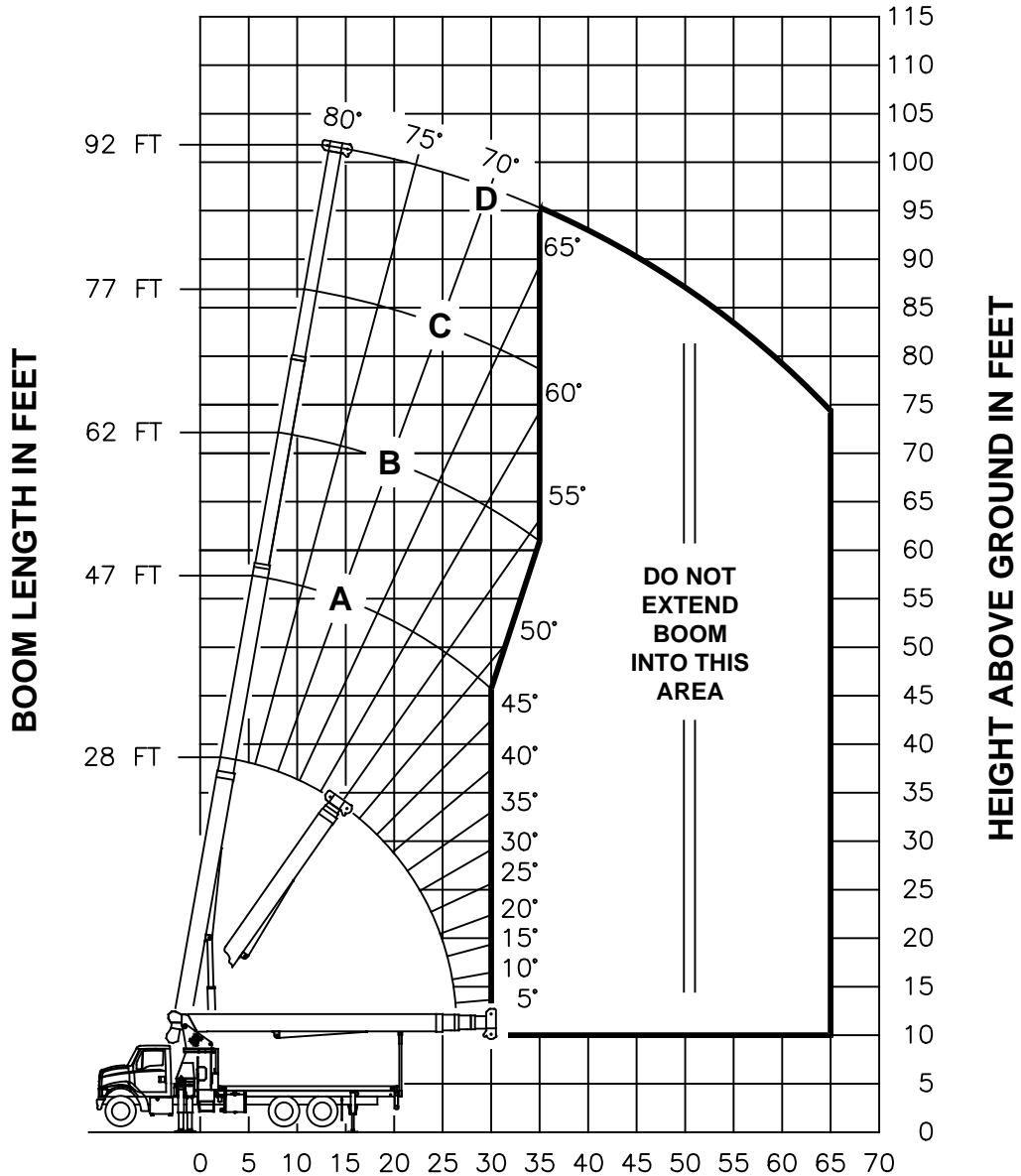

OPERATING RADIUS FROM CENTERLINE OF ROTATION IN FEET

NOTE : LIFTING PERSONNEL WITH CRANE IN THIS OUTRIGGER CONFIGURATION IS STRICTLY PROHIBITED. USE ONLY FULLY EXTENDED OUTRIGGER CONFIGURATION WHEN LIFTING PERSONNEL.

**USE THIS CHART
ONLY WHEN
OUTRIGGERS AND
STABILIZERS ARE
FULLY RETRACTED**

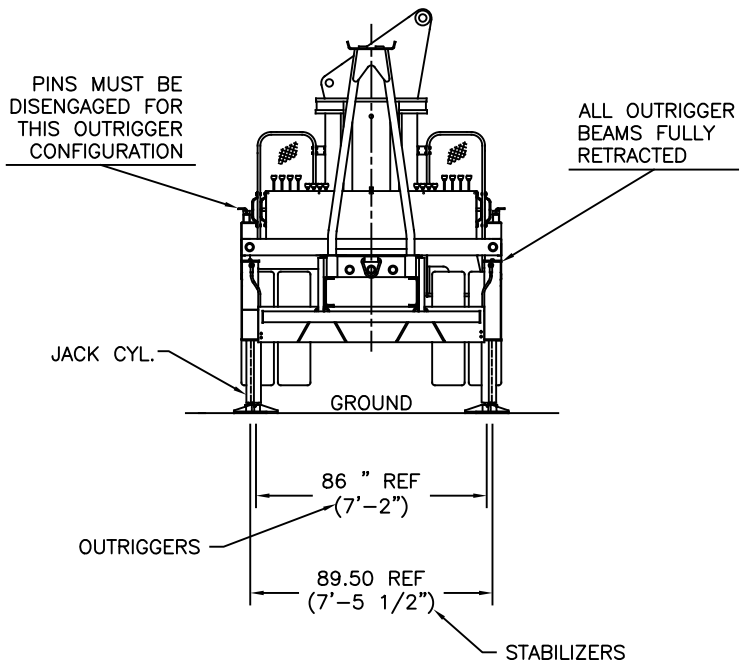

- FULLY RETRACTED SPREAD CONFIGURATION -

MAIN BOOM LOAD RATINGS IN LBS												
LMI CODE #13												
OPERATING RADIUS FT	LOADED BOOM ANGLE BOOM LENGTH AND MARKER											
			A		B		C		D			
	∠	28 FT	∠	47 FT	∠	62 FT	∠	77 FT	∠	92 FT		
5	79	50000										
8	73	22380										
10	69	14340	78	14770								
12	64	10120	76	10520	80	10650						
15	57	6570	72	6940	77	7060	80	7130				
20	43	3510	65	3880	72	3990	76	4060	79	4100		
25	22	1850	58	2240	67	2350	73	2420	76	2460		
30			50	1220	62	1340	69	1400	73	1440		
35					57	640	64	700	70	740		
		460 LBS	270 LBS	210 LBS	170 LBS	140 LBS	DEDUCTIONS FOR STOWED FIXED JIB					
		690 LBS	410 LBS	310 LBS	250 LBS	210 LBS	DEDUCTIONS FOR STOWED TELESCOPIC JIB					

**NO JIBS ARE TO
BE ERECTED IN
THIS
OUTRIGGER
CONFIGURATION**

ALLOWABLE LINE PULL							WARNING
1 PART LINE	2 PART LINE	3 PART LINE	4 PART LINE	5 PART LINE	6 PART LINE	7 PART LINE	
							<p>ANTI-TWO-BLOCK SYSTEM MUST BE IN GOOD OPERATING CONDITION BEFORE OPERATING CRANE.</p> <p>REFER TO THE OWNER'S MANUAL.</p> <p>KEEP AT LEAST 3 WRAPS OF LOAD LINE ON THE DRUM AT ALL TIMES.</p>
8500 LBS	17000 LBS	25500 LBS	34000 LBS	42500 LBS	50000 LBS	50000 LBS	9/16" 6X25 IWRC (3.5:1 SF) - 29750 LBS MIN BREAKING STRENGTH
7700 LBS	15400 LBS	23100 LBS	30800 LBS	38500 LBS	46200 LBS	50000 LBS	9/16" ROT RESISTANT (5.0:1 SF) - 38500 LBS MIN BREAKING STRENGTH

AREA OF OPERATION

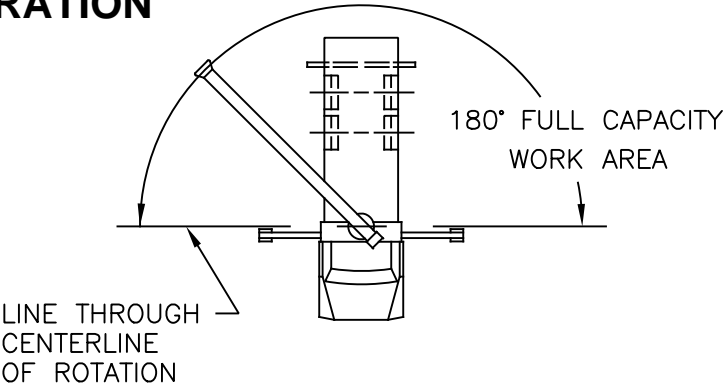

DEDUCTIONS FROM RATED LOADS FOR LOAD HANDLING DEVICES SUPPLIED BY MANITEX

AUXILIARY BLOCK	—	—	—	—	—	—	—	—	—	50 LBS
AUXILIARY SHEAVE	—	—	—	—	—	—	—	—	—	50 LBS
OVERHAUL BALL	—	—	—	—	—	—	—	—	—	SEE OVERHAUL BALL MANUFACTURER NAMEPLATE
LOAD BLOCK	—	—	—	—	—	—	—	—	—	SEE BLOCK MANUFACTURER NAMEPLATE
HOSE REEL	—	—	—	—	—	—	—	—	—	140 LBS
SWING AROUND JIB	—	—	—	—	—	—	—	—	—	SEE LOAD CHART

LMI OPERATING CODES

SETTING	CRANE CONFIGURATION	OUTRIGGER CONFIGURATION
#1	— MAIN BOOM	FULLY EXTENDED
#2	— FIXED JIB	FULLY EXTENDED
#3	— TELESCOPIC JIB—RETRACTED	FULLY EXTENDED
#4	— TELESCOPIC JIB—EXTENDED	FULLY EXTENDED
#5	— PERSONNEL LIFTING PLATFORM ON MAIN BOOM	FULLY EXTENDED
#6	— PERSONNEL LIFTING PLATFORM ON FIXED JIB	FULLY EXTENDED
#7	— PERSONNEL LIFTING PLATFORM ON TELESCOPIC JIB—RETRACTED	FULLY EXTENDED
#8	— PERSONNEL LIFTING PLATFORM ON TELESCOPIC JIB—EXTENDED	FULLY EXTENDED
#9	— MAIN BOOM	INTERMEDIATE
#10	— FIXED JIB	INTERMEDIATE
#11	— TELESCOPIC JIB—RETRACTED	INTERMEDIATE
#12	— TELESCOPIC JIB—EXTENDED	INTERMEDIATE
#13	— MAIN BOOM	FULLY RETRACTED

WARNING

1. THE OPERATOR MUST READ AND UNDERSTAND THE OWNER'S MANUAL BEFORE OPERATING THIS CRANE.

2. POSITIONING OR OPERATION OF CRANE BEYOND AREAS SHOWN ON THIS CHART IS NOT INTENDED OR APPROVED EXCEPT WHERE SPECIFIED IN OWNER'S MANUAL.

3. LOADED BOOM ANGLES AT SPECIFIED BOOM LENGTHS GIVE ONLY AN APPROXIMATION OF THE OPERATING RADIUS. THE BOOM ANGLE BEFORE LOADING SHOULD BE GREATER TO ACCOUNT FOR DEFLECTIONS. DO NOT EXCEED THE OPERATING RADIUS FOR RATED LOADS.

4. THE OPERATING RADIUS SHOWN IN THE JIB RATING CHART IS FOR FULLY EXTENDED BOOM ONLY. WHEN BOOM IS NOT FULLY EXTENDED, USE ONLY LOADED BOOM ANGLE TO DETERMINE LOAD RATING OF JIB.

5. FOR BOOM ANGLES NOT SHOWN ON JIB LOAD RATING CHART, USE RATING OF NEXT LOWER BOOM ANGLE.

6. FOR BOOM LENGTHS NOT SHOWN, USE RATING OF NEXT SHORTER OR LONGER BOOM LENGTH, WHICHEVER IS LESS. FOR RADII NOT SHOWN, USE RATING OF NEXT LONGER RADIUS.

7. CRANE LOAD RATINGS ON OUTRIGGERS ARE BASED ON FREELY SUSPENDED LOADS WITH THE MACHINE LEVELED AND STANDING ON A FIRM UNIFORM SUPPORTING SURFACE. NO ATTEMPT SHALL BE MADE TO MOVE A LOAD HORIZONTALLY ON THE GROUND IN ANY DIRECTION.

WARNING (CONTINUED)

8. PRACTICAL WORKING LOADS DEPEND ON SUPPORTING SURFACE, WIND, AND OTHER FACTORS AFFECTING STABILITY SUCH AS HAZARDOUS SURROUNDINGS, EXPERIENCE OF PERSONNEL, AND PROPER HANDLING, ALL OF WHICH MUST BE TAKEN INTO ACCOUNT BY THE OPERATOR.
9. THE MAXIMUM LOAD WHICH MAY BE TELESCOPED IS LIMITED BY HYDRAULIC PRESSURE, BOOM ANGLE, AND BOOM LUBRICATION. IT IS SAFE TO ATTEMPT TO TELESCOPE ANY LOAD WITHIN THE LIMITS OF THE LOAD RATING CHART.
10. LIFTING OFF THE MAIN BOOM POINT WHILE THE SWING AROUND JIB IS ERECTED IS NOT INTENDED OR APPROVED.

INFORMATION

1. DEDUCTIONS MUST BE MADE FROM RATED LOADS FOR STOWED JIB, OPTIONAL ATTACHMENTS, HOOKS, AND LOADBLOCKS (SEE DEDUCTION CHART). WEIGHTS OF SLINGS AND ALL OTHER LOAD HANDLING DEVICES SHALL BE CONSIDERED A PART OF THE LOAD.
2. LOAD RATINGS ABOVE THE HEAVY LINE ARE STRUCTURALLY LIMITED CAPACITIES. LOAD RATINGS BELOW THE HEAVY LINE ARE STABILITY LIMITED CAPACITIES AND DO NOT EXCEED 85% OF TIPPING.

DEFINITIONS

1. OPERATING RADIUS IS THE HORIZONTAL DISTANCE FROM THE AXIS OF ROTATION TO THE CENTER OF THE VERTICAL HOIST LINE OR TACKLE WITH LOAD APPLIED.
2. LOADED BOOM ANGLE AS SHOWN IN THE COLUMN HEADED BY , IS THE INCLUDED ANGLE BETWEEN THE HORIZONTAL AND LONGITUDINAL AXES OF THE BOOM BASE AFTER LIFTING RATED LOAD AT RATED RADIUS.