



MAGNI
TELESCOPIC HANDLERS

RTH

Courtesy of CraneMarket.com

MAGNI: EXPERIENCE, RELIABILITY AND VERSATILITY

The RTH range is the result of years of experience and research in the field of rotary telehandlers. It reflects and satisfies the needs of our customers and their requirement for reliability and performance.

The RTH range is built to ensure the maximum possible safety and versatility.

Magni versatility is guaranteed by:

- A huge choice of interchangeable attachments for multiple uses, all equipped with the R.F.ID automatic recognition system
- MCTS software which, alongside the CAN BUS system, allows customisation of various usage parameters
- Different types of steering



from **4** to **13** tonnes



MAX. LIFTING
CAPACITY

from **18** to **46** m



MAX. LIFTING
HEIGHT

33 m



MAX. REACH

from **300** to **390** mm



GROUND CLEARANCE
ON TYRES

3 machines in **1**



TELESCOPIC HANDLER
OFF-ROAD CRANE
AERIAL WORK PLATFORM

SMART



RTH 4.18 Smart RTH 5.18 Smart RTH 5.21 Smart RTH 5.23 Smart RTH 5.25 Smart

SH



RTH 5.21 SH RTH 5.23 SH RTH 5.25 SH RTH 6.26 SH RTH 6.30 SH

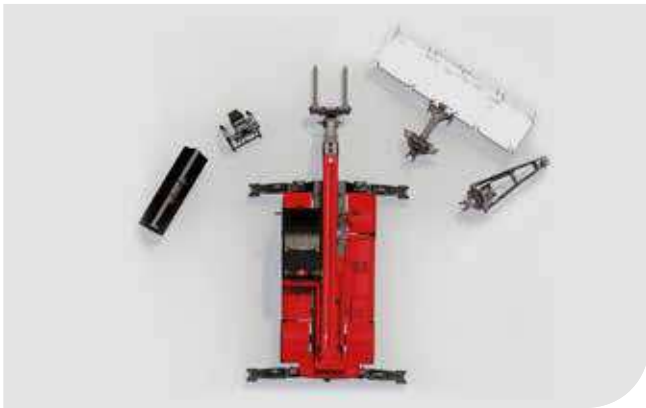

RTH 6.35 SH RTH 6.39 SH RTH 6.46 SH RTH 8.25 SH RTH 13.26 SH



CAB



PATENTED DESIGN, FULL-VISIBILITY CAB

The innovative design of MAGNI's cabs ensures unbeatable operator comfort and safety.

The cab has full visibility thanks to a large windscreen which extends from the operator's head to their feet, allowing them to view the load even when it is suspended overhead or with the boom completely lowered.

The cab is FOPS/ROPS certified and equipped with an upper grill guard to guarantee operator safety even during the most delicate operations.

The adjustable steering column facilitates access to the cab, and allows the operator to achieve their perfect working position.

The cab is hermetically sealed and fully pressurised. The 100% air filtration makes MAGNI machines perfect for use even in contaminated environments, with no risks for the operator.

Heating and air conditioning are standard on all models in the RTH range (excluding the 4.18 Smart).

The cab is also equipped with a practical cup holder.

This is a big hit with operators, allowing them to enjoy their morning coffee or other beverages inside the cab.

(Magni insulated cup available).

The cab also features a USB port as standard for charging tablets and smartphones.



100% air filtration



FOPS/ROPS
pressurised cab



Heating as standard
Air-conditioning



MUG holder

MAGNI CONTROL PANEL

The user-friendly touchscreen display is used to manage the whole machine: it is extremely intuitive, and communicates with the operator via more than 170 written fault messages in 8 different languages. The touchscreen can also be managed via a joystick. The stabilisers and auto-levelling can also be managed via dedicated buttons.



CONTROL PANEL



STANDARD TOUCHSCREEN

All Magni models from 18 to 25 metres are equipped with a 7" touchscreen display. The machine management software installed on the touchscreen gathers all usage data and displays them conveniently over five different pages. Navigating between these pages is extremely easy and intuitive, even for less expert users.



XL TOUCHSCREEN

The cabs of 26 to 46 m models features an even larger touchscreen (10"). The Linux operating system used offers faster, more fluid navigation between pages, even in prolonged use. The larger display offers greater legibility of the load charts. In this model, the touchscreen features updated software which is even faster and easier to use, offering the greatest possible intuitiveness for all operations.

REMOTE CONTROL TYPES

The RTH range can be equipped with two types of remote control that allow all hydraulic movements of the machine to be performed. The most advanced version also allows management of the stabilisers and provides the possibility to drive the machine at up to 5 km/h from a distance of 100 metres.

The remote control joysticks are electro-proportional, just like the one in the cabin, meaning they perfectly reproduce the same precision in the controls.



REMOTE CONTROL

MCTS

MAGNI COMBI TOUCH SYSTEM

The Magni Combi Touch System is a brand new concept in machine management; it is easy to use for both expert and new operators, thanks to its icon-based design which makes it highly intuitive.

The system is divided into 5 main pages, each dedicated to different functions.



1



DRIVE PAGE

All data on the transmission and its components are shown in the upper section, just like a traditional instrument cluster, whereas the lower section allows the driver to select the type of steering. This selection is facilitated by the presence of two alignment sensors. It is also possible to set the speed (tortoise/hare).

2



STABILISATION PAGE

The RTH range has an interactive stabilisation area: each stabiliser automatically recognises its extension. Based on this data, the software provides the operator with a progressive load chart, which increases as the length of the stabiliser increases, so that the machine always has the best chart. Moreover, the RTH range is also equipped with an electronic spirit level, which allows for automatic levelling of the stabilisers.

3

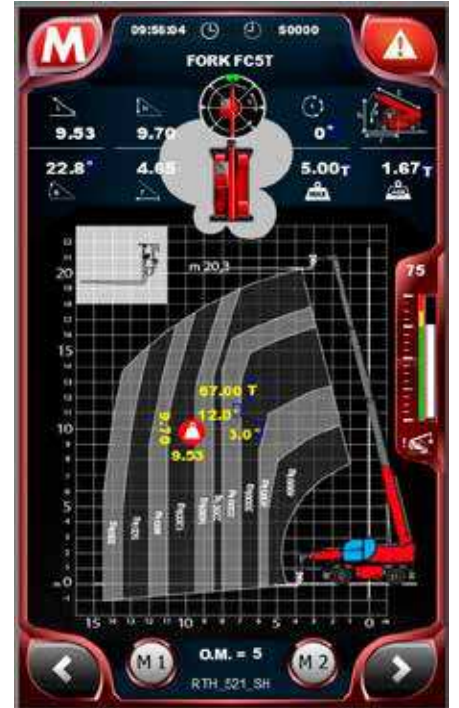

LOAD CHART PAGE

MAGNI uses the "Load Moment Indicator" system which meets all regulations for cranes. The screen displays a dynamic load chart which allows the operator to keep a constant view of the payload's centre of gravity.

4



CONTROL PAGE

The upper section is used to manage basic cab commands (such as temperature and ventilation), the middle section is dedicated to the machine lights, while the lower section displays the various available options for switching from the cab controls to remote control.

5



CUSTOMISATION PAGE

This page displays the limitations for 360° turret rotation and also for the working height. It is also possible to customise the hydraulic speeds for lifting/lowering and extension/retraction of the boom, turret rotation, fork tilting and attachment functions for dangerous or repetitive manoeuvres.



KEY CHARACTERISTICS



BEST LIFTING PERFORMANCE

OPTIMUM LIFTING PERFORMANCE



MAX. LIFTING CAPACITY
from **4** to **13** tonnes



MAX. LIFTING HEIGHT
from **18** to **46** m



MAX. REACH
33 m



360° ROTATION
(Excludes Model 4.18 SMART)



GROUND CLEARANCE



RTH 4.18 Smart - RTH 5.18 Smart - RTH 5.21 Smart - RTH 5.23 Smart - RTH 5.25 Smart	329 mm
RTH 5.21 SH - RTH 5.23 SH - RTH 5.25 SH	330 mm
RTH 6.26 SH	323 mm
RTH 6.30 SH - RTH 6.35 SH - RTH 6.39 SH	320 mm
RTH 6.46 SH - RTH 13.26 SH	390 mm
RTH 8.25 SH	300 mm

PERFORMANCE ON TYRES



LEVELLING SYSTEM ON TYRES

The levelling system on tyres is fitted to all models in the RTH range to adapt to all differences in

level and guarantee maximum operator safety on all types of terrain and on any kind of slope.



OFF-ROAD

The powerful hydrostatic transmission provides each wheel with all the power necessary to tackle the roughest terrain and the toughest slopes. Equipped with four-wheel drive, two forward/reverse gears and a rear tilting axle, the RTH range

guarantees perfect stability and maximum grip. In addition, the impressive ground clearance allows the machine to overcome any obstacle.



GRADEABILITY

MAGNI machines have been designed to handle the toughest slopes, while guaranteeing maximum grip.

4.18 SMART	5.18 SMART	5.21 SMART	5.25 SMART	5.21 SH	5.23 SH	5.25 SH	6.26 SH	6.30 SH	6.35 SH	6.39 SH	6.46 SH	8.25 SH	13.26 SH
41 %	44 %	44 %	41 %	44 %	44 %	41 %	42 %	40 %	43 %	43 %	30 %	43 %	30 %



COMPACT DESIGN

Both the pivoting and scissor stabilisers are perfect for working in tight spaces. The former – thanks to their compact stabilisation area – and the latter – thanks to their extreme flexibility – can, indeed, adapt to the needs of the operator or the site conditions.

THREE TYPES OF STEERING

Each model can be road legal and three different types of steering are available:

- Round steering: offering an improved turning circle for moving in tight spaces
- Front steering: for on-road driving
- Crab steering: allows the machine to approach from the side

Front steering

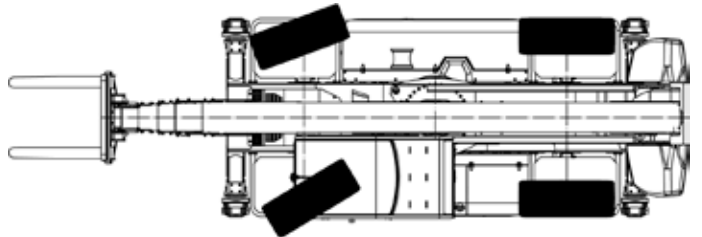

Round steering

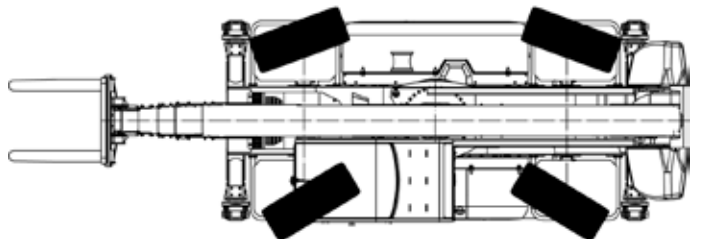

Crab steering

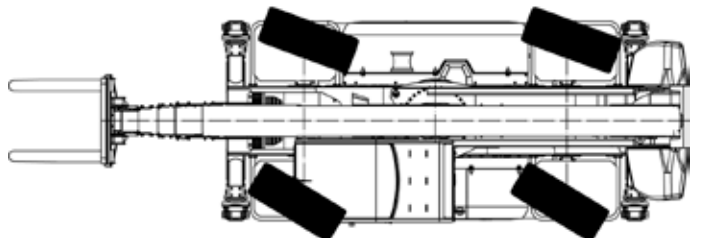



TECHNICAL SPECIFICATIONS

TRANSMISSION

The electronically controlled hydrostatic transmission, composed of an electronically controlled variable displacement pump (500 bar working pressure), ensures accurate and progressive speed regulation to position the load in complete safety. The automatic calibration of the hydrostatic pump and motor with variable displacement offers the perfect balance between speed and pulling force.

The two-speed gearbox offers a high and low speed range for on-road and off-road driving, respectively.

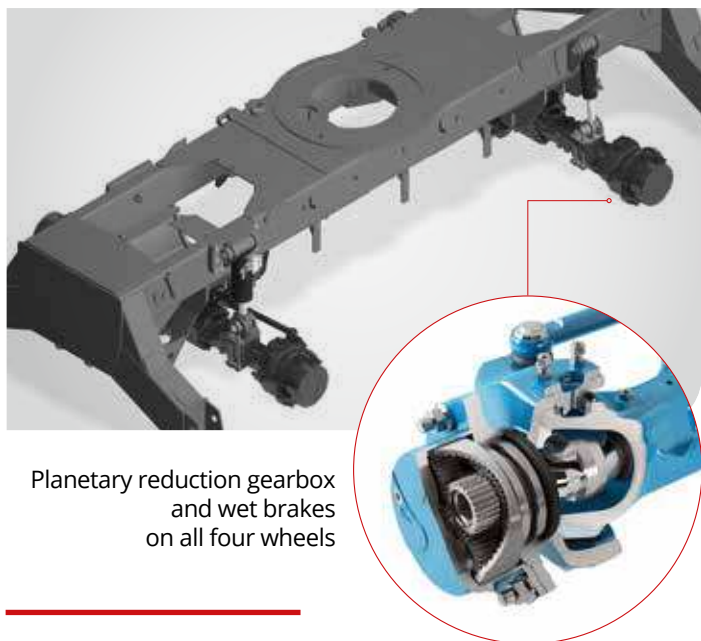

Planetary reduction gearbox and wet brakes on all four wheels

AXLES

The axles of the RTH range, with planetary reduction gearbox and multi-disc wet brakes, have the steering cylinder on the upper part in order to protect them from accidental collisions.

The rear axle is a tilting model to ensure the best off-road performance, but the machine is equipped with automatic differential locking beyond $\pm 5^\circ$ turret rotation to ensure better stability.

AUTOMATIC REAR AXLE DIFFERENTIAL LOCK BEYOND $\pm 5^\circ$ ROTATION

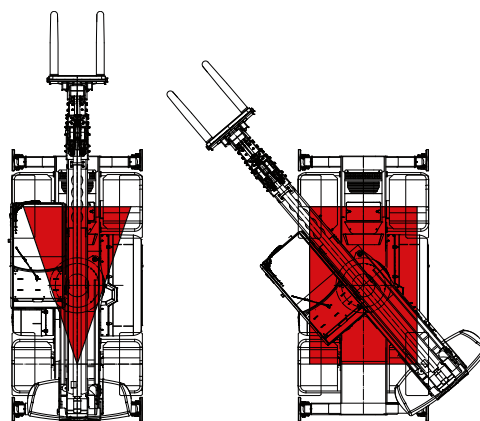

ENGINE

All engines supplied with the RTH range meet the requirements of Directive 97/68/EC regarding emissions.

The Smart range and the smaller models up to the 5.25 SH are fitted with Deutz engines, while the top-of-the-range models have Mercedes MTU turbo engines, with twin-turbo versions for the three highest-performance models.

The electronic management of the transmission ensures its perfect adaptation to the engine's torque curves in order to optimise the use of the components, allowing for a 10-15% reduction in fuel consumption and longer lifetimes for the components themselves.

The engine bay has been designed for easy access, facilitating inspections.



ELECTRICAL & HYDRAULIC CIRCUIT

The load-sensing system (350 bar effective working pressure) is composed of an l/s high pressure pump (for hydraulic movement); two electro-proportional joysticks and a SIL 2 main safety valve which complies with EN 13489 concerning the safety of electronic controls. Gas-tight couplings, thermoplastic hoses and steel pipes ensure a perfect seal.

The electronic management of the hydraulic system allows it to select the best engine speed for the hydraulic power required, providing reductions in fuel consumption.

Magni software allows management of flow sharing, guaranteeing both safety and precision of hydraulic movements (up to 3/4 movements at a time).



The IP67-rated electric circuit is protected against water and dust ingress, and runs at 24V.

The RTH range is equipped with a CAN BUS, which handles all data relating to the electronic components. All information regarding the engine, transmission, hydraulic system and load moment indicator is shown on the touchscreen display.

CAN BUS technology requires around a third less wiring, reducing the risk of faults on the circuit and increasing overall reliability of the machine.

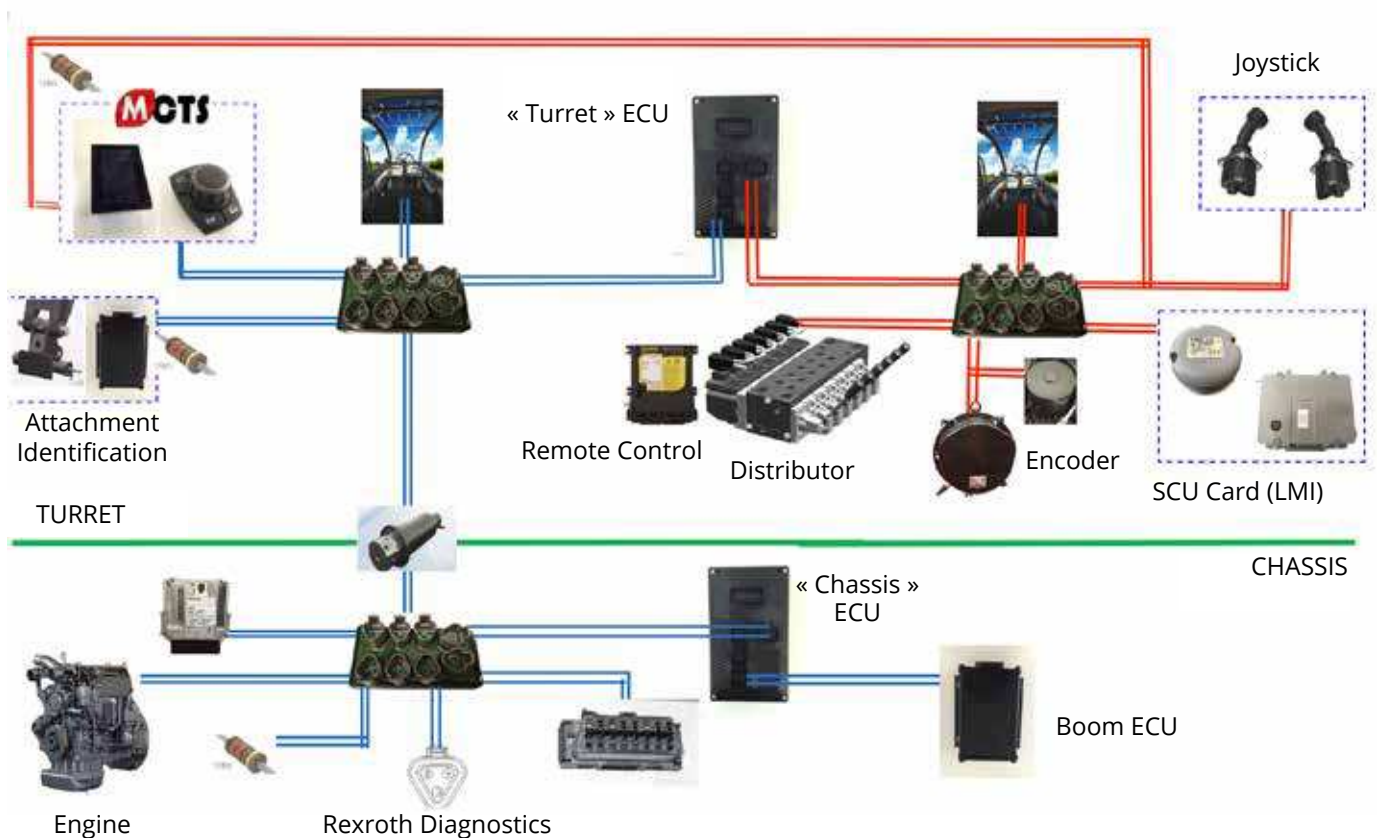
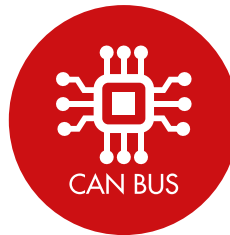

TECHNICAL SPECIFICATIONS

BOOM

Manufactured from high-tensile steel, the boom is extremely tough and rigid but at the same time very light, increasing the load capacity and preventing it from flexing. The telescopic extension of the sections is actuated by a cylinder. A dual-chain system and hydraulic hoses completely contained inside the boom itself significantly reduce accidental breakages due to collisions.

The block is composed of two 3+3 bundles, preventing rubbing between the individual lines and maintaining alignment, thus also contributing to a significant reduction in faults. The sliding pads are fastened to steel blocks, ensuring smooth movement of the structure.

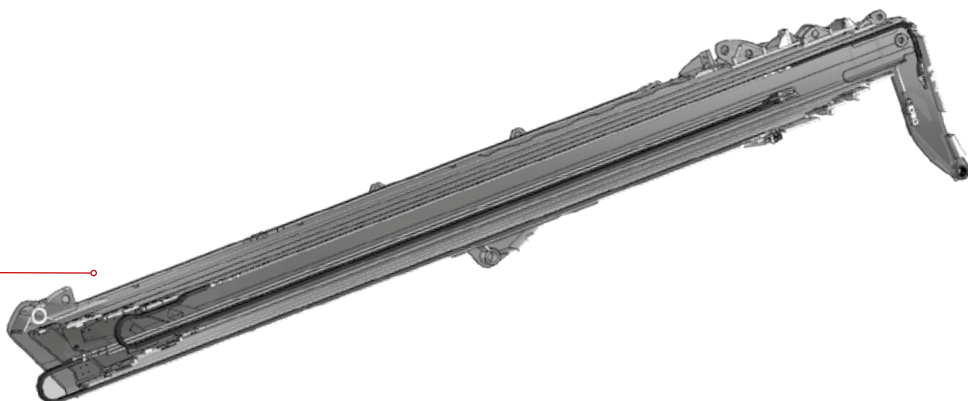
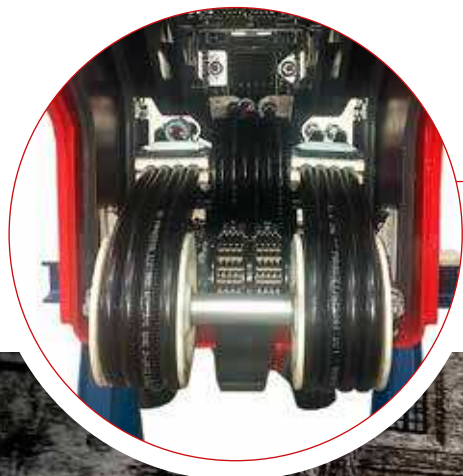
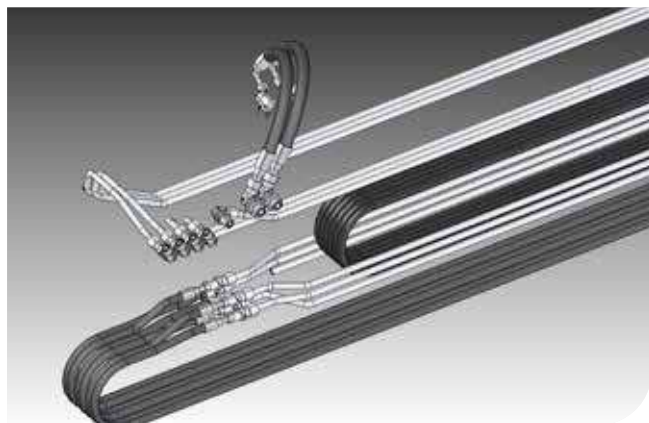

AUTOMATIC ATTACHMENT RECOGNITION

An R.F.ID automatic attachment recognition system is fitted as standard to all models in the RTH range, installed on the boom head.

When the attachment is coupled to the machine, it is recognised automatically, the display is consequently updated with the corresponding load chart and the load limit device is set for that specific attachment. Thanks to its reduced weight, the new quick-fit system offers improved lifting capacity.

This system makes the RTH range much safer, preventing the risk of selecting incorrect attachments.





SMART SERIES

The SMART series is equipped with pivoting stabilisers. The compact size of the chassis is complemented by the pivoting stabilisers installed on the same axis; when these are closed they do not protrude from the outline of the machine, and do not affect its ground clearance.

When they are opened, on the other hand, they form a very compact stabilisation area of just 427 cm, while maintaining impressive lifting capacity.

The performance of the Smart Series is highlighted by its 3000 mm wheelbase which also allows for more advantageous tyre capacities, while compactness is assured by the increased steering angle, offering an improved turning circle to allow manoeuvring even in tight spaces.



The lifting and lowering process allows for optimal grip on any kind of ground thanks to the large contact surface; at the same time, it allows for closure of the stabiliser foot without protrusion.



	RTH 4.18 SMART	RTH 5.18 SMART	RTH 5.21 SMART	RTH 5.23 SMART	RTH 5.25 SMART
--	----------------------	----------------------	----------------------	----------------------	----------------------

	A	350 mm	350 mm	350 mm	350 mm	350 mm
	B	304 mm	304 mm	304 mm	304 mm	304 mm

Maximum pressure on ground (kgf/cm²)	12	12	13	13	13
--	----	----	----	----	----

SH SERIES

The SH series is equipped with scissor stabilisers. Scissor stabilisers have zero protrusion when closed. Their overlapping beams are fastened to the chassis without affecting ground clearance. The stabilisers can be managed simultaneously or individually in order to adapt perfectly to the work zone.

The stabiliser extension and retraction process guarantees



perfect grip on any kind of ground thanks to the large contact area, thus preventing the risk of sinking into the ground. At the same time, it ensures automatic closing of the stabiliser feet without protrusion.

Thanks to their great flexibility, scissor stabilisers do not require much space to stabilise the machine. Even when it is only partially stabilised, the machine is programmed to provide the best possible load chart on each side.

When they are fully extended, on the other hand, the stabilisers guarantee maximum 360° performance thanks to the square stabilisation base.

		5.21 SH	5.23 SH	5.25 SH	6.26 SH	6.30 SH	6.35 SH	6.39 SH	6.46 SH	8.25 SH	13.26 SH
	A	390 mm	390 mm	390 mm	490 mm	490 mm	490 mm	490 mm	637 mm	490 mm	637 mm
	B	437.7 mm	437.7 mm	437.7 mm	437.7 mm	437.7 mm	437.7 mm	437.7 mm	466 mm	437.7 mm	466 mm
Maximum pressure on ground (kgf/cm ²)		12	12	12	12	12	12	12	13	12	13

STABILISERS
PARTIALLY
EXTENDED

=

GUARANTEED
STABILITY

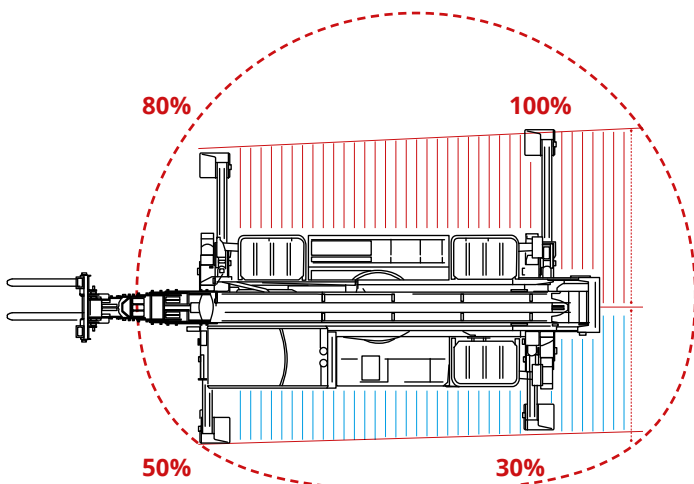

LOAD MOMENT INDICATOR

In order to ensure maximum safety, all machines in the RTH range meet product standards for forklift trucks, cranes and aerial work platforms. All MAGNI telescopic handlers are equipped with a load limit device which stores specific load charts for each attachment and continuously analyses the spatial positioning of the load, dynamically displaying the correct load chart based on the machine's working configuration. If an overload occurs, it automatically stops any movement which would aggravate the situation, allowing only for retraction.



A



Boom angle and length detection potentiometer with redundant safety devices.

B



Load weight detection via 4 pressure transducers: 2 installed on the lifting cylinders and 2 on the compensation cylinder.

C

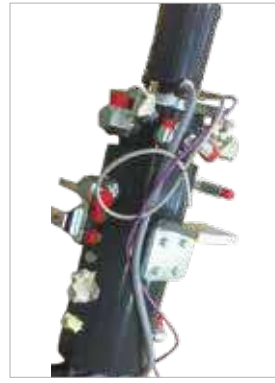

Turret position detection via rotation sensors installed within the rotating joint.

E



Flashing light.

F



Dynamic representation of all the collected data on the touchscreen display for the operator.

D



Automatic detection of stabiliser configuration via potentiometers installed inside the beams to ensure their protection.







Magni Telescopic Handlers Srl

Via Magellano, 22 – 41013 Castelfranco Emilia (MO)

Tel. +39 059 8630811- Fax +39 059 8638012

commerciale@magnith.com - www.magnith.com