



Link-Belt
C R A N E S

HTC 3140 HTC 3140 LB

140 U.S. ton | 120 metric ton Hydraulic Truck Crane
140 U.S. ton | 120 metric ton Hydraulic Truck Crane

- **HTC-3140 LB** 42.3 ft to 195.3 ft (12.9-59.5m) 6-section pin & latch boom
- **HTC-3140** 41.4 ft to 162 ft (12.6-49.3m) 5-section pin & latch boom
- No charted capacity deductions for telescoping loads
- Five boom extend modes provide superior capacities: EM1 – EM5
- Optional 10-31-55 ft (3.0-9.4-16.7m) three-piece, bi-fold, on-board lattice attachment with 2°, 15°, 30°, and 45° manual offsets, and 2° through 45° hydraulic offsets
- Optional three 18 ft (5.5m) fly extensions plus 55 ft (16.7m) provide a total attachment length of 109 ft (33.2m)
- **HTC-3140 LB** 311 ft (94.8m) maximum tip height
- **HTC-3140** 278 ft (84.7m) maximum tip height
- Modular style counterweights
- 25,955 lbs (115.5kN) maximum winch line pull
- 405 fpm (123.4m/min) maximum winch line speed
- Next generation operator's cab with improved visibility and ergonomics
- Automated manual transmission with 2-speed auxiliary transmission
- Anti-lock (ABS) brakes
- "Stow 'n Go" steel pontoons

HTC 3140

HTC 3140_{LB}

- 5 and 6-section pin & latch boom with attachment flexibility
- Big, wide cab with outstanding visibility
- Winches deliver impressive numbers of line pull and line speed
- Counterweight flexibility, big engine and transmission power, along with hydro-gas suspension promise incredible mobility on the road or on the job



10-31-55 ft (3.0-9.4-16.7 m)
three-piece bi-fold lattice attachment
with 2°, 15°, 30° and 45° manual
offsets and 2°-45° hydraulic offsets

Outstanding mobility on the road and on the job site

- Cruise control
- Three stage engine **compression brake**
- Ether injection system—optional
- **Automated transmission** (no clutch pedal) –11 speeds forward, 3 speeds reverse with 2 modes of operation: **fully automatic and semi-automatic**
- **Two-speed auxiliary transmission**
- **Job site travel** is permissible with all 60,000 lbs (27 215 kg) of counterweight for exceptional job site versatility.
- Up to 0.32 mph (0.51 km/hr) job site travel
- **Highway speeds up to 65.6 mph (105.61 km/hr)** are unmatched in the industry today.



Comfortable carrier cab:

- Dash-mounted **comprehensive instrumentation** with back-lit gauge
- Roll up/down door window provides **excellent ventilation**
- Fully adjustable **air-ride fabric seat**
- **Suspended pedals**



Boom dolly/trailer ready

when equipped with optional boom float kit, rear electrical and air connections.

Optional **rear electrical and air connections**



Auxiliary winch can be removed and installed without an assist crane using only the top and bottom tray of the counterweight stack. Counterweight removal system allows all counterweight configurations to be raised and lowered by hydraulic cylinders from the comfort of the operator's cab.

Two standard **locking storage boxes**.



Pin & latching boom with attachment flexibility

- **Quick reeve boom head** eliminates the need to remove the becket when it becomes necessary to change the reeving
- **Five extend modes** for superior capacities throughout the extension range
- Available **two or three-piece bi-fold lattice fly** which allow the tip section to be stored, thus enhancing the lifting performance when using the base section
- Boom requires **no greasing** because of ingenious Teflon wear pucks impregnated in the full contact wear pads
- Two available **offset fly options**: manual offset with 2°, 15°, 30°, and 45°, and a hydraulic offset with 2° - 45° with no capacity deduction for luffing loads
- **No deducts** for stowed attachments



Quick reeve boom head eliminates the need to remove the becket when reeving is changed.

Standard boom dolly connections

Mechanical boom angle indicator - standard

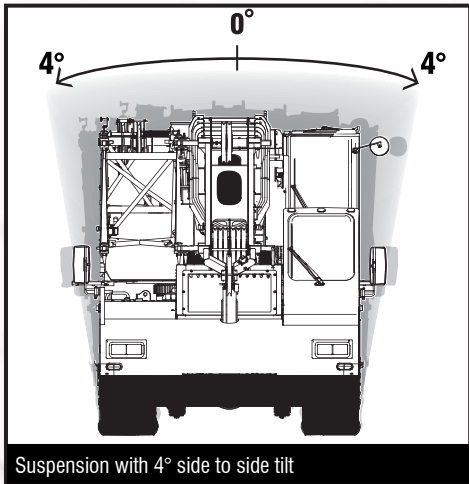

Large engine doors allow for easy access

Side view camera

Daytime running lights

Self-storing fifth outrigger pontoon

Overhead console for document storage with AM/FM radio

Large west coast-style rear viewing mirrors

Full air, S-cam anti-lock (ABS) brakes

Aluminum wheels and radial tires

Stow 'n Go outrigger pontoons

20° tilting cab

Standard integrated air conditioning

Pull-out CabWalk™ slides out from secured travel position underneath operator's cab

Non-slip surface strips on carrier deck

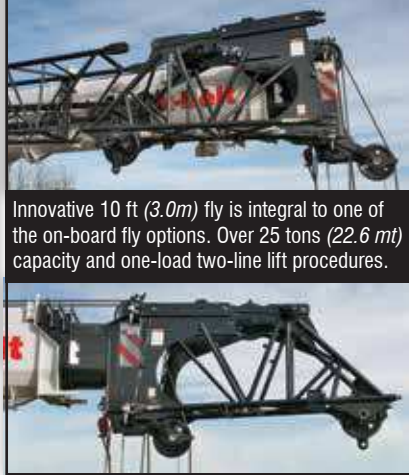

Innovative 10 ft (3.0m) fly is integral to one of the on-board fly options. Over 25 tons (22.6 mt) capacity and one-load two-line lift procedures.



Powerful and responsive hydraulics

- Six pump, pressure compensated hydraulic system allows **simultaneous and precise function** of boom hoist, winch and swing.
- Two-speed hydraulic piston motor system **delivers superior hoisting**.
- Matched size optional front and rear winches provide equal **max line pulls of 25,955 lbs (115.5 kN)** and **max line speeds of 405 fpm (123.4 m/min)** on 16 inch (.41 m) root diameter grooved drums.
- **Drum rotation indicators** - standard.
- **Bi-directional hydraulic swing motor** mounted to a planetary reduction unit for 360° swing. **Spring applied hydraulic released 360° swing park brake** provides infinite swing park positions as well as free swing when control is in a neutral position.

Optional Lattice Fly Onboard

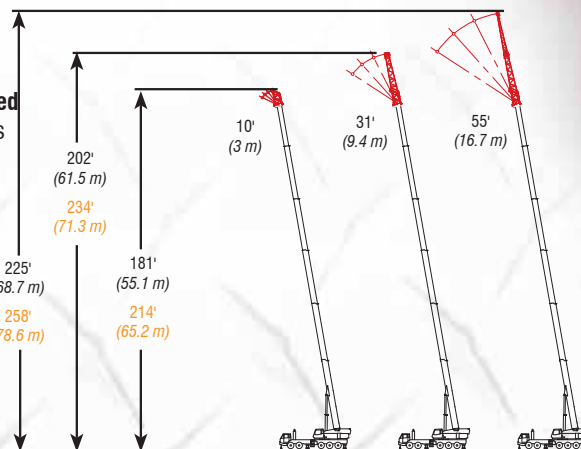

Optional hoist drum cable follower and optional third wrap indicators

Winch viewing cameras

Hydraulic assist winch removal

Rear camera

Optional Lattice Fly Extension

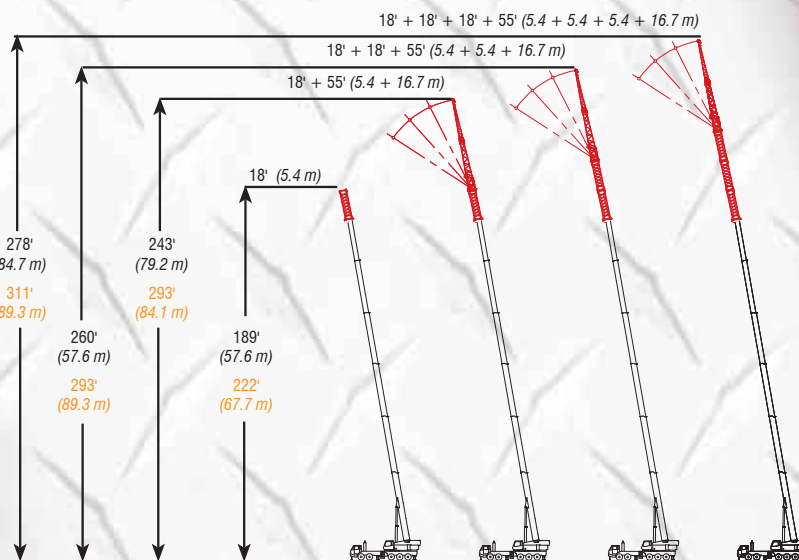

Black = HTC-3140 Orange = HTC-3140 LB

Carrier-mounted outrigger controls, located on each side of the carrier, include an engine throttle-up switch for fast outrigger deployment. For fine level adjusting of the carrier, throttle can be taken down to idle.

Stow 'n Go outrigger pontoons are quickly and easily stored and secured for travel, eliminating the need to remove the pontoon each time the crane moves. Pontoon storage space is also available on rear fenders and side access ladders.



The Confined Area Lifting Capacities (CALC) system provides three outrigger positions:

- full retraction
- intermediate extension
- full extension

Outrigger pins eliminate guesswork by automatically positioning outriggers at midpoint position.

Roomier and quieter operator's cab

- **Extra large front window** seamlessly merges into the roof window
- Sliding left side door, right and rear windows, and swing up top window provide **excellent ventilation**
- All gauges, switches, indicators and controls are placed in the operator's forward line of sight for **excellent ergonomics**
- **All gauges and switches are backlit** for optimal visibility when the cab working lights are switched to the on position
- **Integrated air conditioning** utilizes the same ventilation outlets as the standard heating system



Multiple counterweight configurations give you capacities for any size job

- **Standard** - Total of 10,800 lbs (4.8 mt) of removable counterweights. Capacities for four different counterweight configurations.
- **Optional** - Up to 18,400 lbs (8.2 mt) of removable counterweights. Capacities for up to six different counterweight configurations.
- All configurations can be raised and lowered by controls located on each side of the upper structure for ease of installation and removal.



Superior accessibility

Access to the operator's cab and engine compartment is superb with strategically located ladders and steps. The pull-out CabWalk™ slides out from its secured travel position underneath the operator's cab, giving the operator a platform to stand on for easy entry and exit from the cab.



Access to the engine compartments and the operator's cab is superb with strategically-located ladders and steps.



Total crane operating system

Link-Belt PULSE

Link-Belt Pulse is the Link-Belt designed total crane operating system. It includes the rated capacity limiter, boom extend mode controller (EMC), self-diagnostic capabilities and continuous monitoring of multiple crane functions and conditions. To aid operators in a safe and efficient operation, its high-resolution, color-intense graphic display provides excellent contrast even in direct sunlight.



Out of cab external light bar



Internal light bar



Telematics. You own the data!

Cellular-based data logging and monitoring system that provides:

- Viewing options for sharing data with distributor and Link-Belt
- Location and operational settings
- Monitor routine maintenance intervals
- Crane and engine monitoring
- Diagnostic and fault codes



Link-Belt Construction Equipment Company is a leader in the design, manufacture and sales of telescopic and lattice boom cranes with headquarters and manufacturing facilities in Lexington, Kentucky, USA. Link-Belt is committed to the manufacture and service of high quality products that satisfy customers worldwide

Towards that end, Link-Belt has pursued a strategy of growth and investment. It has moved aggressively to seize more global market share by producing a broader range of products and strengthening distribution and personnel around the globe.

Link-Belt is also home to a family of passionate professionals with a legacy of innovation and cutting-edge technology spanning over 140 years. These professionals, in a 740,000 sq. ft. (68 748 m2) manufacturing facility and with a culture of continuous innovation, have pushed Link-Belt to be the most modern crane manufacturer in North America.

**Your crane investment is always protected...
with your Link-Belt distributor.**

When you invest in a Link-Belt crane, you invest in a legacy of outstanding customer support dating back to 1874. The ultimate value of a machine begins with state-of-the-art design and quality manufacturing, but it is the excellent Link-Belt distributor product support that determines its long term value. This philosophy has earned Link-Belt cranes the enviable position of traditionally commanding some of the highest resale prices in the industry.

... to be recognized as a
leader
customer service & satisfaction.
— The Link-Belt Vision

Link-Belt
Preferred

As a member of Link-Belt Cranes user's group, you will have access to:

- A comprehensive online library of parts, service & operator manuals for **YOUR** crane
- Interactive, live groundbearing calculations for **YOUR** crane
- Plus a vast array of information on new products, services and special offerings
- Online access to recommended spare parts lists, filter, lube and key lists plus maintenance information and more
- No annual fee or charges to access your crane information

**Online
3D LIFT
PLANNING**

- Web-based, active 3D, high graphic
- User-friendly, no CAD program required
- Always current, no updates required
- Print actual lift



**Online
GROUNDBEARING
PRESSURES**

- Dynamic specific machine model pontoon loadings
- Graphically illustrated in 360° numerical presentation
- Print out



**Link-Belt
was born
because our
founding father
understood the
importance of
replacement parts.**

William Banta Everett

Building on that principal...

- Trained technical specialists
- Faster and more efficient customer service
- State of the art computer information systems
- 24 hours a day, 7 days a week
- 72,000 Sq. Ft. Parts Distribution Center
- All parts in stock ship the same business day

**Link-Belt
CRANES
GENUINE
PARTS**



©Link-Belt is a registered trademark. Copyright 2015
All rights reserved. We reserve the right to change
designs and specifications at any time. 1534
Litho in U.S.A. 11/15 #4476 (supersedes #4412)

Link-Belt
CRANES
Lexington, Kentucky | www.linkbelt.com

Courtesy of CraneMarket