

Technical Data

Specifications & Capacities
Imperial/Metric

TCC 1400

Telescopic Crawler Crane
140 Ton (125 metric ton)

CE

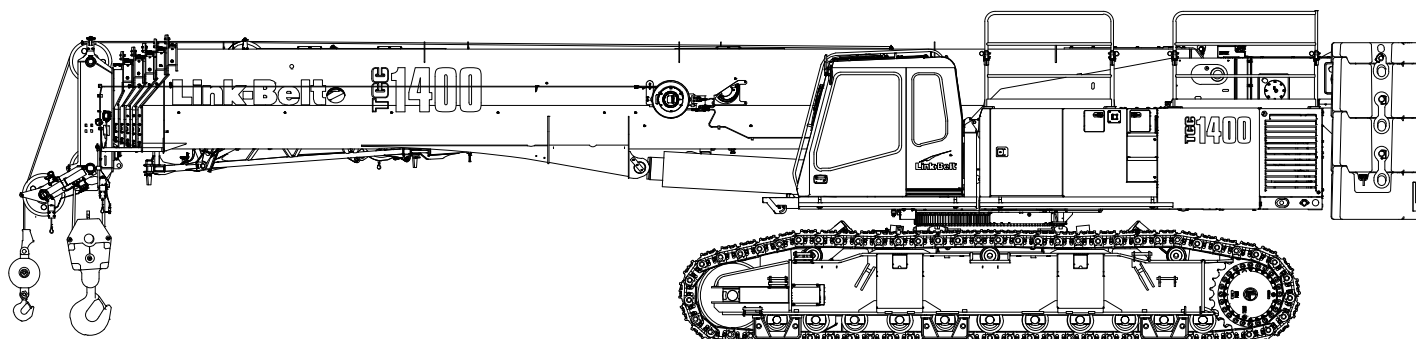

CAUTION: This material is supplied for reference use only. Operator must refer to in-cab Crane Rating Manual and Operator's Manual to determine allowable crane lifting capacities and assembly and operating procedures.

Table Of Contents

Upper Structure	1
Frame	1
Engine	1
Hydraulic System	1
Load Hoist Drums	1
Swing System	1
Counterweight	1
Operator's Cab	1
Rated Capacity Limiter System	2
Machinery House	2
Catwalks	2
Optional	2
Lower Structure	2
Carbody	2
Side Frames	2
Travel and Steering	2
Jack System	2
Optional Tool Boxes	2
Boom	3
Design	3
Boom	3
Optional	3
Boom Wear Pads	3
Boom Head	3
Boom Elevation	3
Optional Equipment	3
Hook Blocks And Balls	3
Fly & Attachments	3
Dimensions	4
Base Crane	4
Auxiliary Lifting Sheave	6
Fly	6
Side Frames	6
Counterweights	7
Hook Balls	8
Hook Blocks	8
Working Weights	10
Transport Drawing	10
Load Hoist Performance	10
Working Areas	11
Boom Extend Modes	12
Working Range Diagrams	13
Main Boom	13
195.4' Main Boom + 10' Fly	14
180' Main Boom + 10, 31-55' Fly	15

Main Boom Load Charts – Standard	16
Main Boom - EM1 Boom Mode	16
Main Boom - EM2 Boom Mode	17
Main Boom - EM3 Boom Mode	18
Main Boom - EM4 Boom Mode	19
Main Boom - EM5 Boom Mode	20
Fly Attachment Load Charts – Standard	21
Main Boom EM2 + 10' Offset Fly	21
Main Boom EM2 + 31' Offset Fly	25
Main Boom EM2 + 55' Offset Fly	27
Main Boom Load Charts – Metric	29
Main Boom - EM1 Boom Mode	29
Main Boom - EM2 Boom Mode	30
Main Boom - EM3 Boom Mode	31
Main Boom - EM4 Boom Mode	32
Main Boom - EM5 Boom Mode	33
Fly Attachment Load Charts – Metric	34
Main Boom EM2 + 3.0m Offset Fly	34
Main Boom EM2 + 9.4m Offset Fly	38
Main Boom EM2 + 16.7m Offset Fly	40

Upper Structure

Frame

All welded steel frame with precision machined surfaces for mating parts.

Turntable Bearing

- Inner race is bolted to upper frame
- Outer race with external swing gear is bolted to lower frame

Engine

Engine

Full pressure lubrication, oil filter, air cleaner, hour meter, throttle, and electric control shutdown.

Specification	Cummins QSL	
	Tier 4f Stage IV ⁽¹⁾	Tier 3/ Stage IIIA ⁽²⁾
Emissions Compliance Level:		
Numbers of Cylinders	6	6
Cycle	4	4
Bore & Stroke: inch (mm)	4.49 x 5.69 (114 x 145)	4.49 x 5.69 (114 x 145)
Piston Displacement: in ³ (L)	543 (8.90)	543 (8.90)
Max. Brake Horsepower: hp (kW)	320 (239) @ 1,800 rpm	325 (242) @ 1,800 rpm
Peak Torque: ft lb (Nm)	1,050 (1 424) @ 1,500 rpm	1,050 (1 424) @ 1,500 rpm
Electric/starting systems: volts	12/12	12/12
Alternator: amps	160	160
Crankcase Capacity: qt (L)	24 (22.7)	24 (22.7)
<ul style="list-style-type: none"> • Water/fuel separator w/ heater and water in fuel (WIF) sensor • 120-volt block heater • Grid heater – 200 amp • ⁽¹⁾ Can only be sold and/or operated where Tier 4f and Stage IV off-high way emission standards are accepted. • ⁽²⁾ Can only be sold and/or operated where Tier 3 and Stage IIIA off-high way emission standards are accepted. 		

Fuel Tank

One 110 gal (416L) capacity fuel tank.

Hydraulic System

Hydraulic Pumps

The pump arrangement is designed to provide hydraulically powered functions allowing positive, precise control with independent or simultaneous operation of all crane functions.

- Two variable displacement pumps provide independent control for hoist drums, boom hoist, boom extend, and right & left travel.
- Two gear type pumps are used for the swing, counterweight removal, track extend/retract, tilting cab, jacks, operator's controls, and hydraulic oil cooling fan.

Hydraulic Reservoir

250 gal (946L) capacity equipped with sight level gauge. Diffusers built in for deaeration.

Filtration

One 10 micron, full flow return line filter. Accessible for easy filter replacement.

Counterbalance Valves

All hoist motors are equipped with counterbalance valves to provide positive load lowering and prevent accidental load drop if the hydraulic pressure is suddenly lost.

Load Hoist Drums

Main and Optional Auxiliary Winches

- Axial piston, full and half displacement (2-speed) motor driven through planetary reduction unit for positive control under all load conditions.
- Grooved lagging
- Power up/down mode of operation
- Hoist drum cable follower – standard
- Drum rotation indicator
- Drum diameter: 15 in (38.1cm)
- Rope length:
 - Main: 900 ft (274.3m)
 - Auxiliary: 650 ft (152.4m)
- Maximum rope storage: 951 ft (198.1m)
- Terminator style socket and wedge

Third wrap indicator – optional – Visually and audibly warns the operator when the wire rope is on the first/bottom layer and when the wire rope is down to the last three wraps

Swing System

Dual Swing Drives

Motor/Planetary – Bi-directional hydraulic swing motor mounted to a planetary reducer for 360° continuous smooth swing at 1.2 rpm

Swing Park Brake – 360°, electric over hydraulic, (spring applied/hydraulic re-

leased) multi-disc brake mounted on the planetary reducer. Operated by a switch in the operator's cab.

Swing Brake – 360°, foot operated, electric over hydraulic proportional metering valve

House Lock – Four-position house lock (boom over front, rear or sides) operated from the operator's cab

Counterweight

Consists of a six piece design.

- One "A" counterweight, 19,000 lb (8 618kg)
- One "B" counterweight, 16,000 lb (7 257kg)
- One "C" counterweight, 16,000 lb (7 257kg)
- One "D" counterweight, 6,000 lb (2 721kg)
- Two "A" carbody counterweights, 12,500 lb (5 670kg) each

Operator's Cab

Fully enclosed modular steel compartment is independently mounted and padded to protect against vibration and noise. Tilting cab 0–20°

- All tinted/tempered safety glass
- Sliding entry door and front and rear window
- Swing up roof window with windshield wiper
- Door and window locks
- Hot water heater
- Air conditioner
- Sun visor
- Cloth seat
- Circulating fan
- Front windshield and top hatch wipers and washers
- Dry chemical fire extinguisher
- Engine instrumentation panel (tachometer, voltmeter, engine oil pressure, engine water temperature, fuel level, hydraulic oil temperature, hour meter, and service monitor system)
- Mechanical drum rotation indicators for main (rear) and auxiliary (front) hoist drums
- Six way adjustable seat
- Foot throttle
- Single axis pilot operated controls
 - Optional Joystick controls
- Fully adjustable single axis controls
- Bubble type level
- Ergonomic gauge layout
- Controls shut off lever
- AM/FM Radio
- Travel levers & pedals
- Monitor for rear view and winch cameras

Rated Capacity Limiter System

Link–Belt Pulse – The Link–Belt in–house designed, total crane operating system that utilizes the display as a readout and operator interface for the following systems:

- Crane configuration
- Boom length
- Boom head height
- Allowed load and % of allowed load
- Data logging
- Boom angle
- Radius of load
- Actual load
- Ground bearing pressures (simulated and real time)
- Electronic level indicator
- Operator settable alarms (include):
 - Maximum and minimum boom angles
 - Maximum tip height
 - Maximum boom length
 - Swing left/right positions
 - Operator defined area (imaginary plane)
- External bar graph indicator
- Optional internal bar graph indicator

Telematics – Cellular–based data logging and monitoring system that provides:

- Location and operational settings
- Routine maintenance
- Crane and engine monitoring
- Diagnostic and fault codes

Machinery House

Hinged doors (four on right side, one on left side) for machinery access. Upper left side guard rails.

- Upper centralized grease bank
- Centralized hydraulic pressure ports

Catwalks

Standard on right and left sides. Catwalks fold up and pin for reduced travel width.

Optional

- Upper mounted remote control flood light
- One amber strobe beacon on top of cab
- One amber strobe beacon on top of the cab

Lower Structure

Carbody

Lower Frame

All welded box construction frame with precision machined surfaces for turntable bearing and axles beams.

Extendable & retractable axle beam controlled by a hydraulic cylinder mounted inside the beams.

- Lower centralized grease bank

Side Frames

Side Frames

All welded, precision machined, steel frames can be extended and retracted with hydraulic cylinders.

- 15 ft 2.2 in (4.63m) extended gauge
- 12 ft 8.7 in (3.88m) intermediate gauge
- 8 ft 11.6 in (2.73m) retracted gauge
- 23 ft 4.2 in (7.11m) overall length
- 36 in (0.91m) wide track shoes
- Sealed (oil filled) idler and drive planetaries
- 2 speed travel drives
- Hydraulic self adjusting tracks

Track Rollers

- Eleven sealed (oil filled) bottom track rollers per side frame
- Three sealed (oil filled) top track rollers per side frame
- Heat treated, mounted on anti–friction bearings

Tracks

Heat treated, self–cleaning grouser shoes and heat treated track pins. 65 track shoes per side.

- Optional flat steel or “street” pad
- Optional rubber clamp on pads

Take Up Idlers

Cast steel, heat treated, self–cleaning, mounted on sealed tapered roller bearings

Travel and Steering

Each side frame contains a pilot controlled, bi–directional, axial piston motor and a planetary gear reduction unit to provide positive control under all load conditions.

- 2–speed travel
- Individual control provides smooth, precise maneuverability including full counter–rotation.

- Spring applied, hydraulically released multiple wet–disc type brake controlled automatically
- Maximum travel speed is 2 mph (3.2km/h)
- Designed to 40% gradeability

Jack System

System contains four hydraulic cylinders individually mounted on swing–out beams.

- Individual jack cylinders are operated by remote control, or can be operated by carbody–mounted controls.
- Minimum height of carbody when resting on pontoons is 14.7 in (37.4cm).
- Maximum height of carbody with jack fully extended is 45.5 in (115.6cm).

Optional Tool Boxes

Two heavy duty steel design tool boxes that bolt onto the carbody counterweights.

Boom

Design

Six section, formed construction of extra high tensile steel consisting of one base section and five telescoping sections. The two plate design of each section has multiple longitudinal bends for superior strength. Each telescoping section extends independently by means of one double-acting, single stage hydraulic cylinder with integral holding valves.

Boom

- 42.4–195.4 ft (12.9–59.5m) six section boom
- Five boom extend modes (EM1 through EM5), controlled from the operator's cab, provide superior capacities by varying the extension of the telescoping sections:
 - EM1 extends to 195.4 ft (59.5m)
 - EM2 extends to 180.4 ft (54.9m)
 - EM3 extends to 154.9 ft (47.2m)
 - EM4 extends to 129.4 ft (39.4m)
 - EM5 extends to 103.6 ft (31.5m)
- Mechanical boom angle indicator
- Wind speed indicator
- Maximum tip height for each extend mode is:
 - EM1 is 203 ft (61.9m)
 - EM2 is 188 ft (57.3m)
 - EM3 is 163 ft (51.2m)
 - EM4 is 138 ft (42.1m)
 - EM5 is 112 ft (34.1m)

Optional

- Remote control boom floodlight

Boom Wear Pads

- Wear pads with Teflon inserts that self-lubricate the boom sections
- Bottom wear pads are universal for T2–T5 telescoping boom sections
- Bottom wear pads are universal for the boom base section and T1 boom section
- Top wear pads are universal for all boom sections

Boom Head

- Six 16.38 in (41.6cm) root diameter nylon sheaves to handle up to 12 parts of line
- Single 16.5 in (41.9m) root diameter nylon auxiliary lifting sheave
- Does not affect erection of the fly or use of the main head sheaves
- Easily removable wire rope guards
- Rope dead end lugs on each side of the boom head
- Boom head is designed for quick-reeve of the hook block

Boom Elevation

- One double acting hydraulic cylinder with integral holding valve
- Boom elevation: –2.5° to 81°

Optional Equipment

Hook Blocks And Balls

- 35 ton (31.8mt) 1 sheave quick-reeve hook block with safety latch
- 50 ton (45.4mt) 4 sheave quick-reeve hook block with safety latch
- 80 ton (72.6mt) 5 sheave quick-reeve hook block with safety latch
- 100 ton (90.7mt) 6 sheave quick-reeve hook block with safety latch
- 140 ton (127mt) 7 sheave quick-reeve hook block with safety latch
- 12 ton (10.9mt) swivel and non-swivel hook balls with safety latch

Fly & Attachments

- 10 ft (3.0m) lattice fly, stowable, offsettable to 0°, 15°, 30°, and 45°. Maximum tip height is 211' 6" (64.5m).
- 10–31 ft two piece lattice fly, stowable, offsettable to 0°, 15°, 30°, and 45°. Maximum tip height is 231' 11" (70.7m).
- 10–31–55 ft three piece bi-fold lattice fly, stowable, offsettable to 0°, 15°, 30°, and 45°. Maximum tip height is 257' 7" (78.5m).

Dimensions

Base Crane

General Dimensions	English	Metric
Basic Boom	42.4-195.4 ft	12.92-59.56m
Minimum Load Radius	8 ft	2.44m
Maximum Boom Angle	81°	81°
Track Shoe Width	36 in	0.91m

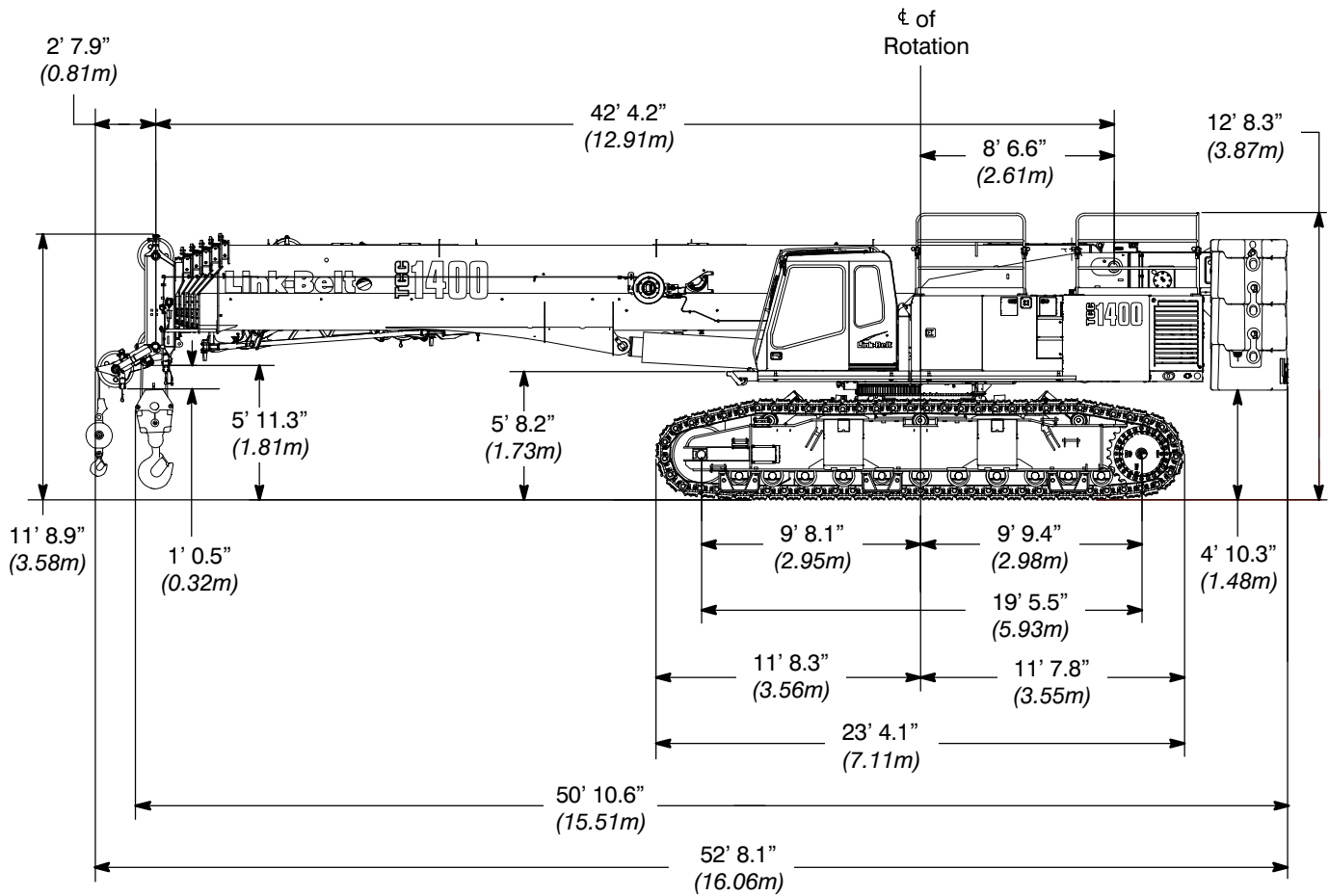

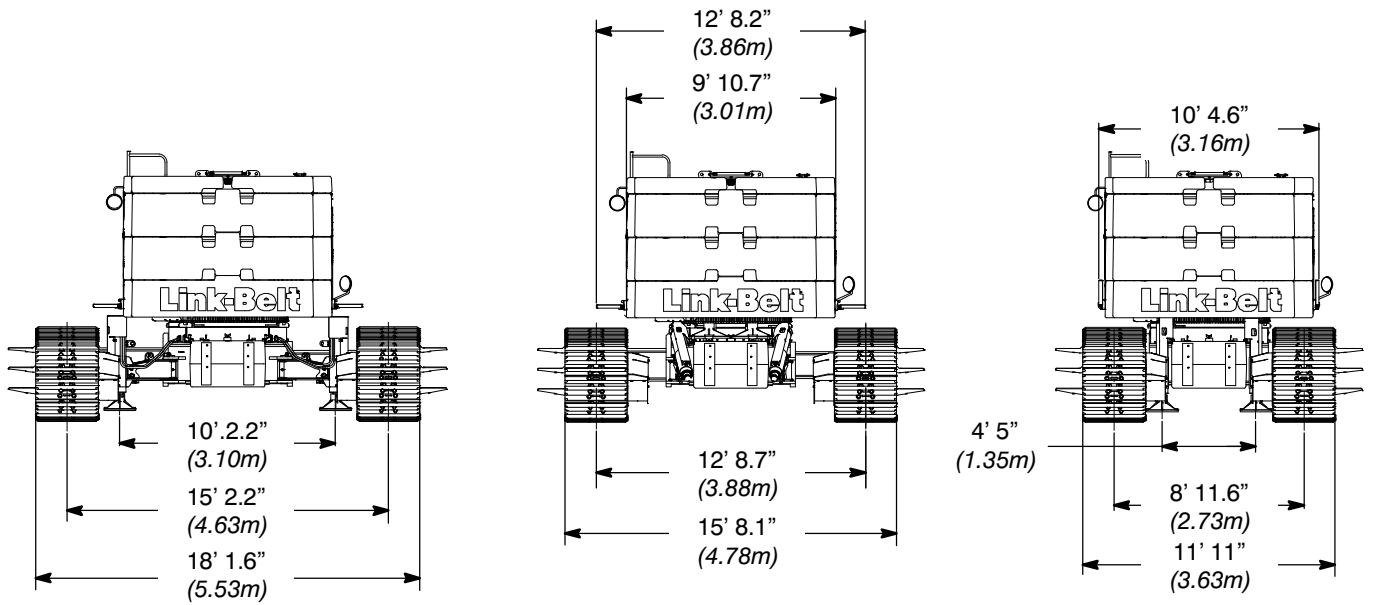
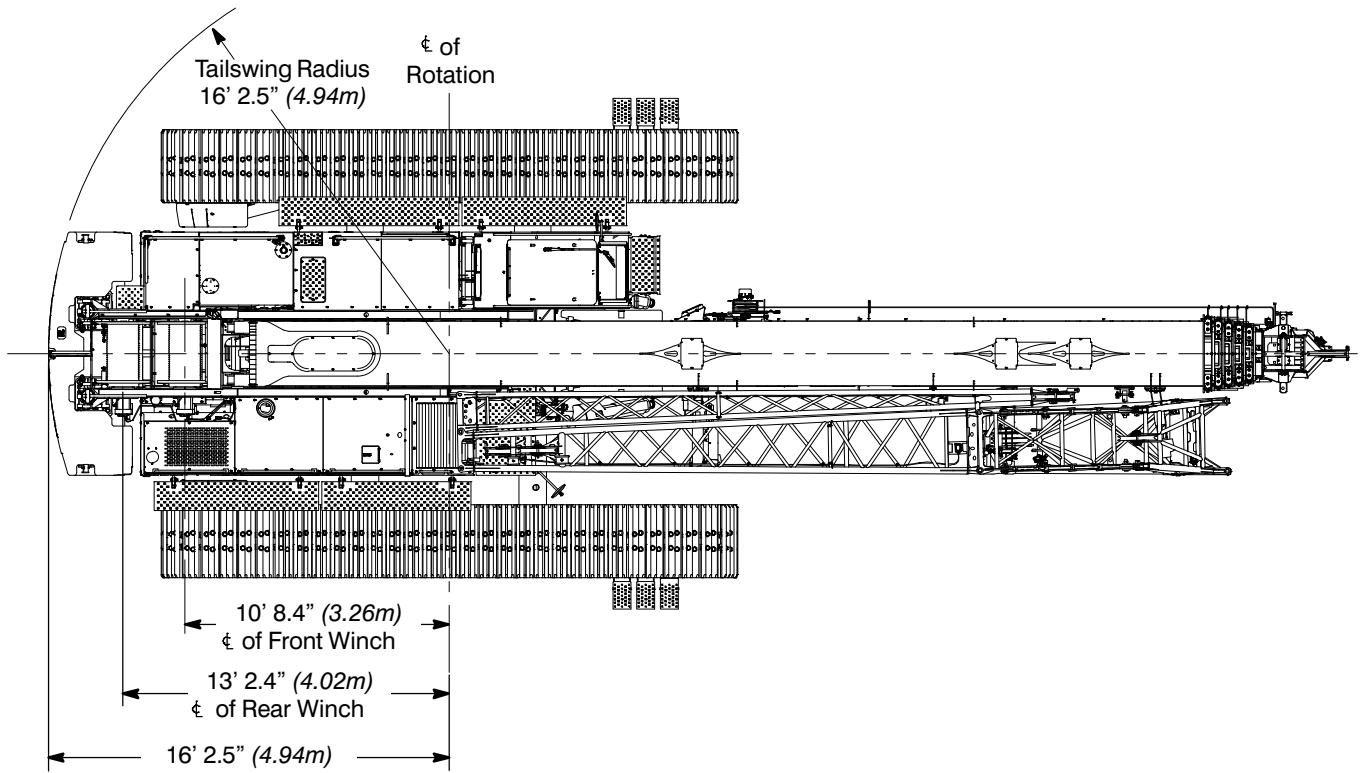

Extended Gauge

Intermediate Gauge

Retracted Gauge

Side Frames

Side Frames ②

Length	280.14 in	(7.12m)
Width	35.84 in	(0.91m)
Height	53.50 in	(1.36m)
Weight	28,750 lb	(13 041kg)

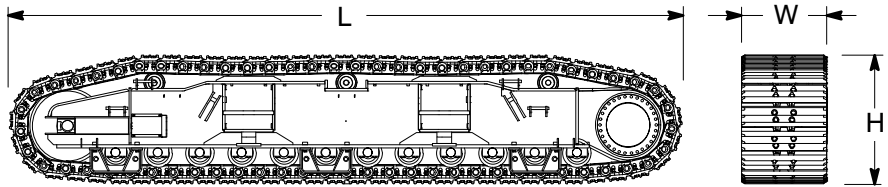

Auxiliary Lifting Sheave

Auxiliary Lifting Sheave ①

Length	11.28 in	(0.29m)
Width	5.59 in	(0.14m)
Height	4.75 in	(0.12m)
Weight	120 lb	(54kg)

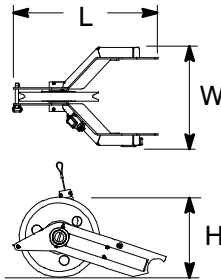

Fly

10 ft (3.0m) Fly Base ①

Length	10.59 ft	(3.23m)
Width	39.43 in	(1.00m)
Height	61.77 in	(1.57m)
Weight	1552 lb	(704kg)

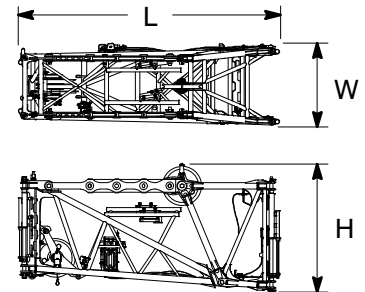

10-31 ft (3.0-9.4m) Two Piece Fly Base And Center ①

Length	31.95 ft	(9.7m)
Width	39.43 in	(1.0m)
Height	61.77 in	(1.57m)
Weight	2,755 lb	(1 249.6kg)

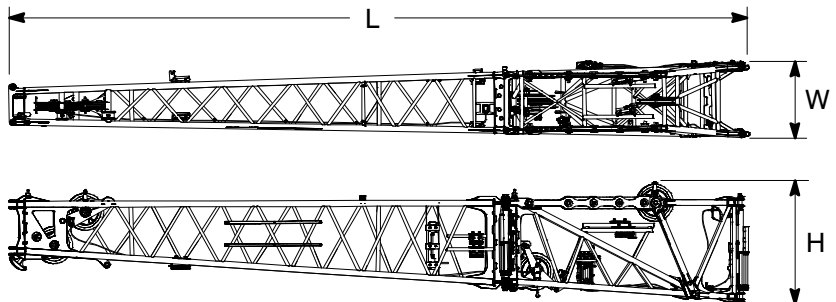

24 ft (7.3) Fly Tip (Addition To Fly Base And Center For 10-31-55 ft (3.0-9.4-16.7m) Bi-fold Fly) ①

Length	25.22 ft	(7.69m)
Width	30.38 in	(0.77m)
Height	34.66 in	(0.88m)
Weight	703.7 lb	(319.2kg)

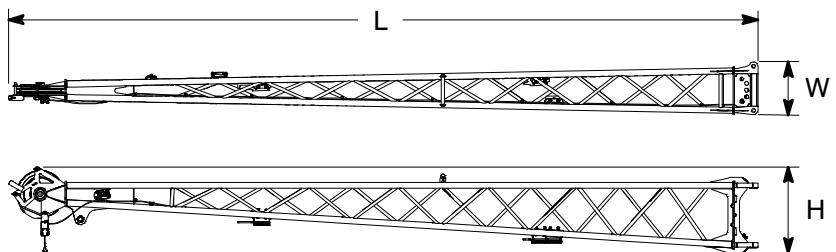

Number inside black circle "①" = # of components

* - Optional equipment

Counterweights

“A” Counterweight ①

Length	40.64 in	(1.03m)
Width	9 ft 10 in	(3.00m)
Height	6 ft 7.0 in	(2.00m)
Weight	19,000 lb	(8 618kg)

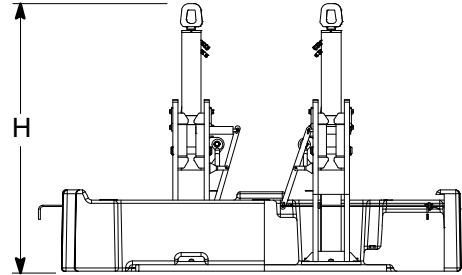
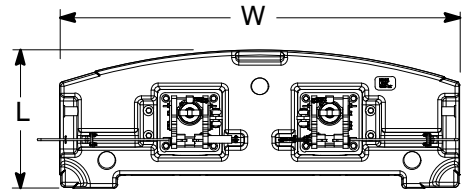

“B” & “C” Counterweights ②

Length	40.7 in	(1.03m)
Width	9 ft 10 in	(3.00m)
Height	27.20 in	(0.69m)
Weight	16,000 lb	(7 257kg)

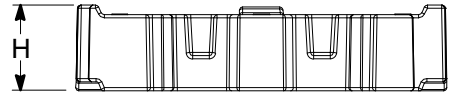
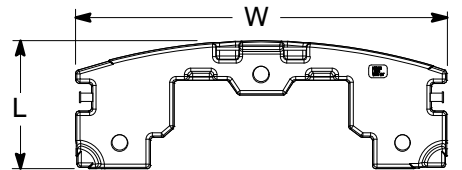

“D” Counterweight ①

Length	40.7 in	(1.03m)
Width	9 ft 10 in	(3.00m)
Height	9.3 in	(0.24m)
Weight	6,000 lb	(2 721kg)

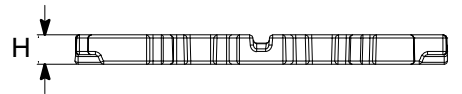
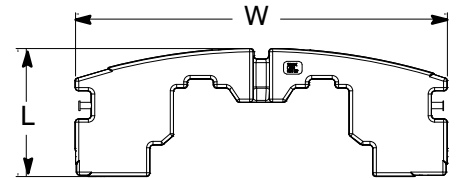

“A” Carbody Counterweights ②

Length	49.0 in	(1.24m)
Width	42.5 in	(1.08m)
Height	26.0 in	(0.66m)
Weight	12,500 lb	(5 670kg)

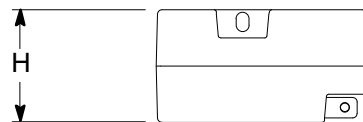
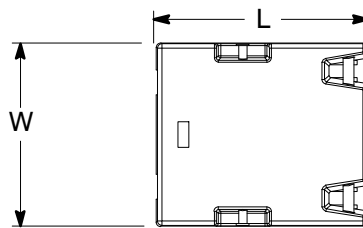

Number inside black circle “①” = # of components

* – Optional equipment

Hook Balls

12 Ton (10.9mt) Swivel

Hook Ball* ①

Width	17.93 in	(0.46m)
Height	36.26 in	(0.92m)
Weight	722 lb	(327kg)

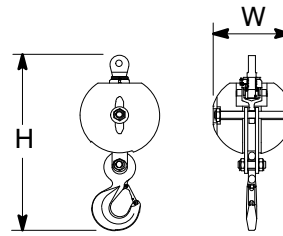

12 Ton (10.9mt) Non-Swivel

Hook Ball* ①

Width	17.93 in	(0.46m)
Height	36.26 in	(0.92m)
Weight	722 lb	(327kg)

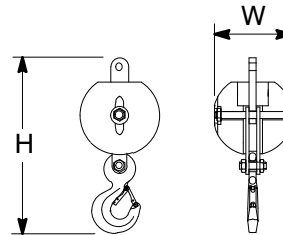

Hook Blocks

35 Ton (31.8mt)

1-Sheave Hook Block* ①

Width1	11.19 in	(0.28m)
Width2	23.88 in	(0.61m)
Height	57.31 in	(1.46m)
Weight	1,100 lb	(499kg)

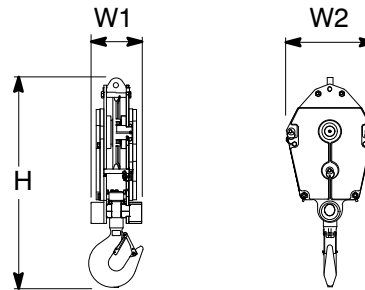

50 Ton (45.4mt)

4-Sheave Hook Block* ①

Width1	15.81 in	(0.40m)
Width2	24 in	(0.61m)
Height	57.35 in	(1.46m)
Weight	1,195 lb	(542kg)

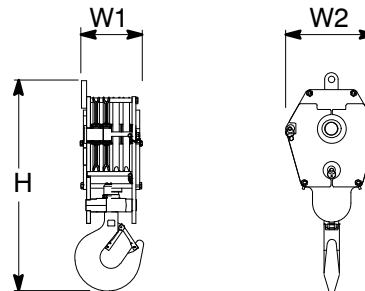

80 Ton (72.6mt)

5-Sheave Hook Block* ①

Width1	20 in	(0.51m)
Width2	24 in	(0.61m)
Height	64.56 in	(1.64m)
Weight	1,411 lb	(640kg)

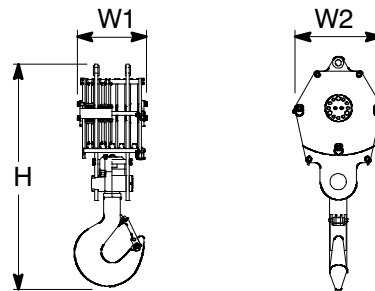

Number inside black circle “①” = # of components

* – Optional equipment

100 Ton (90.7mt) 6-Sheave Hook Block* ①

Width1	20.94 in	(0.53m)
Width2	24 in	(0.61m)
Height	67.61 in	(1.72m)
Weight	1,750 lb	(794kg)

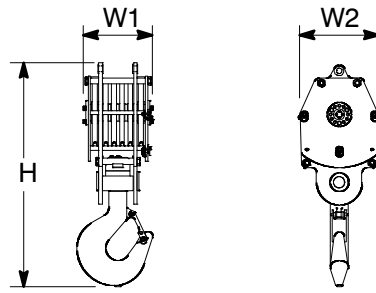

140 Ton (127.0mt) 7-Sheave Hook Block* ①

Width1	23.10 in	(0.54m)
Width2	22.25 in	(0.57m)
Height	72.28 in	(1.84m)
Weight	2,850 lb	(1 292kg)

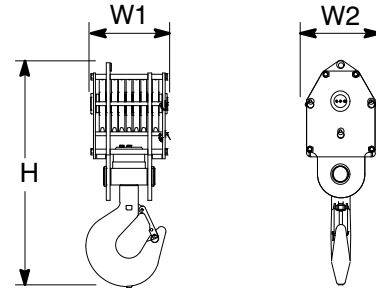

Number inside black circle “①” = # of components
* – Optional equipment

Working Weights

Option	Description	Gross Weight lb (kg)	Ground Bearing Pressure (on soft ground) psi (kg/cm ²)
1	Base crane, "ABCD" counterweight, 2 piece carbody counterweight, 900 ft (274.3m) type "ZB" main wire rope, 600 ft (182.9m) type "ZB" auxiliary wire rope, 2-piece fly, 80 ton (72.6mt) 5 sheave hook block, and 12 ton (10.89mt) hook ball. and a 200 lb (90.7kg) operator.	233,300 (105 823kg)	13.94 (0.98)

Notes: Ground bearing pressure is based on the total weight distributed evenly over the track contact area.

Transport Drawing

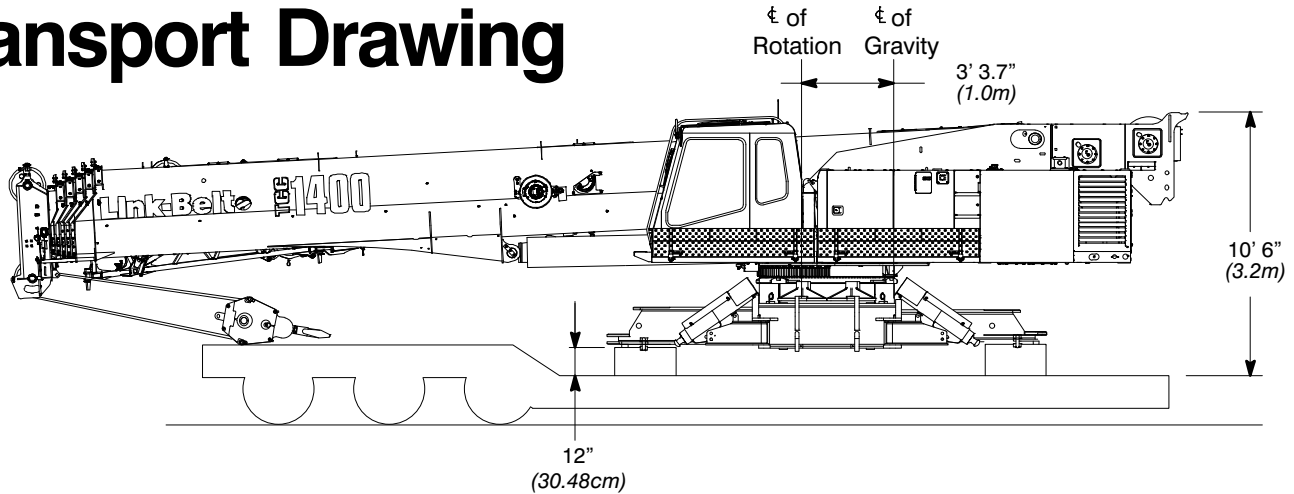

Transport Weight – 93,600 lb (42 456kg)

Base crane, 900 ft (274.32m) type "ZB" main wire rope, 600 ft (182.88m) type "ZB" auxiliary wire rope, 2-piece fly, 80 ton (72.6mt) 5 sheave hook block, and 12 ton (10.89mt) hook ball

Load Hoist Performance

Main (Rear) and Auxiliary (Front) Winches – 7/8 in (22mm) Rope										
Layer	Maximum Line Pull		Normal Line Speed		High Line Speed		Layer		Total	
	lb	kg	ft/min	m/min	ft/min	m/min	ft	m	ft	m
1	22,380	10,151.4	174	53.0	348	106.1	125	38.1	125	38.1
2	20,194	9,159.8	193	58.8	386	117.7	138	42.1	263	80.2
3	18,397	8,344.7	212	64.6	424	129.2	152	46.3	415	126.5
4	16,893	7,662.5	230	70.1	461	140.5	165	50.3	580	176.8
5	15,617	7,083.8	249	75.9	499	152.1	179	54.6	758	231.0
6	14,520	6,586.2	268	81.7	537	163.7	192	58.5	951	289.9

Wire Rope Application		Diameter		Type	Maximum Permissible Load	
		in	mm		lb	kg
Main (Rear) Winch	Standard	7/8	22	36x7 rotation resistant – right regular lay or right lang lay (Type ZB)	20,920	9 489.2
	Optional	7/8	22	18x19 rotation resistant – right regular lay or right lang lay (Type RB)	17,520	7 946.9
Auxiliary (Front) Winch	Standard	7/8	22	36x7 rotation resistant – right regular lay (Type ZB)	20,920	9 989.2
	Optional	7/8	22	18x19 rotation resistant – right regular lay (Type RB)	17,520	7 946.9

Working Areas

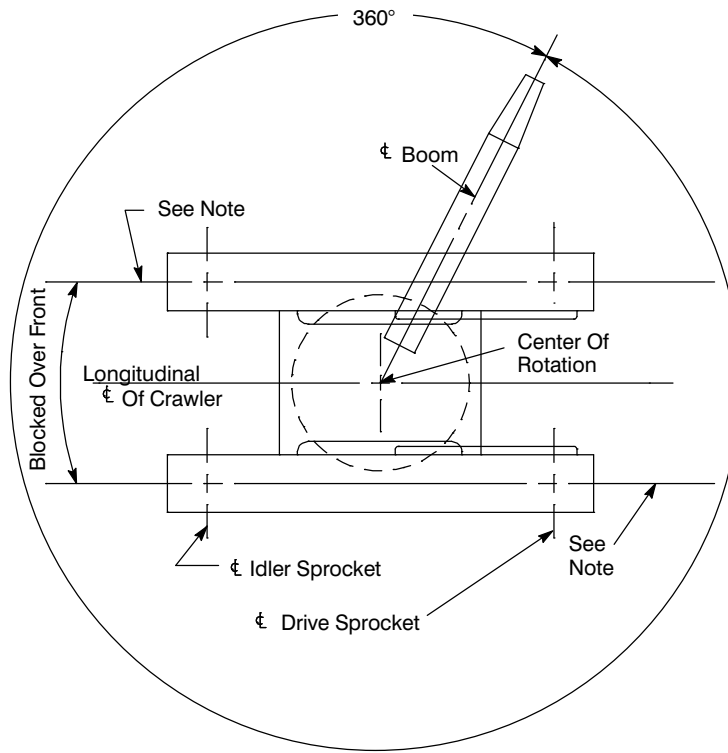

Note: These Lines Determine The Limiting Position Of Any Load For Operation Within Working Areas Indicated.

Boom Extend Modes

Boom Length		Telescope Length				
ft	m	T5	T4	T3	T2	T1
42.3	12.88					
55	16.8	44%				
70	21.3	96%				
85	25.9	100%	46%			
100	30.5	100%	97%			
115	35.1	100%	100%	46%		
130	39.6	100%	100%	95%		
145	44.2	100%	100%	100%	43%	
160	48.8	100%	100%	100%	90%	
175	53.3	100%	100%	100%	100%	37%
185	56.4	100%	100%	100%	100%	68%
195.4	59.52	100%	100%	100%	100%	100%

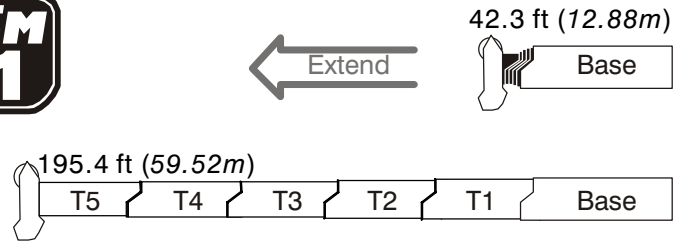

Boom Length		Telescope Length				
ft	m	T5	T4	T3	T2	T1
42.3	12.88					
55	16.8	44%				
70	21.3	90%	6%			
85	25.9	90%	57%			
100	30.5	90%	90%	17%		
115	35.1	90%	90%	66%		
130	39.6	90%	90%	90%	24%	
145	44.2	90%	90%	90%	71%	
160	48.8	90%	90%	90%	90%	28%
170	51.8	90%	90%	90%	90%	59%
180.3	54.94	90%	90%	90%	90%	91%

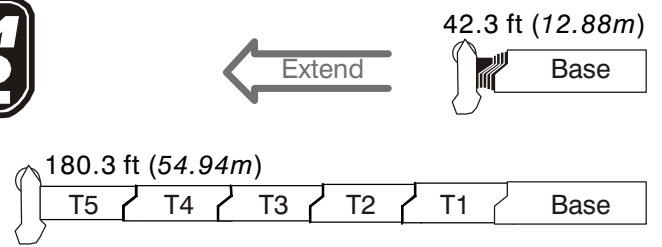

Boom Length		Telescope Length				
ft	m	T5	T4	T3	T2	T1
42.3	12.88					
55	16.8	44%				
70	21.3	46%	47%	1%		
85	25.9	46%	47%	50%		
100	30.5	46%	47%	90%	9%	
115	35.1	46%	47%	90%	457%	
130	39.6	46%	47%	90%	90%	13%
145	44.2	46%	47%	90%	90%	60%
155	47.23	46%	47%	90%	90%	91%

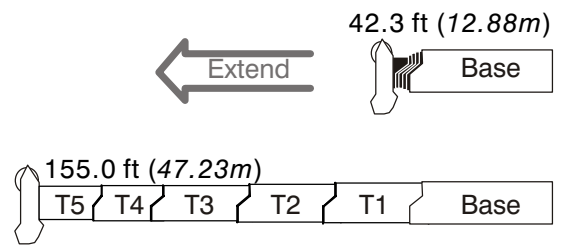

Boom Length		Telescope Length				
ft	m	T5	T4	T3	T2	T1
42.3	12.88					
55	16.8	44%				
70	21.3	46%	47%	1%		
85	25.9	46%	47%	49%	2%	
100	30.5	46%	47%	49%	49%	
115	35.1	46%	47%	49%	50%	46%
129.6	39.49	46%	47%	49%	50%	91%

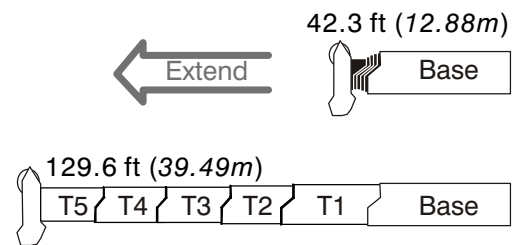

Boom Length		Telescope Length				
ft	m	T5	T4	T3	T2	T1
42.3	12.88					
56.4	17.18	0%	47%			
71.3	21.72	0%	47%	49%		
87.1	26.53	0%	47%	49%	50%	
103.7	31.61	0%	47%	49%	50%	51%



FIXED

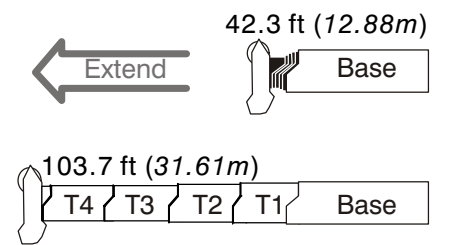

Working Range Diagrams

Main Boom

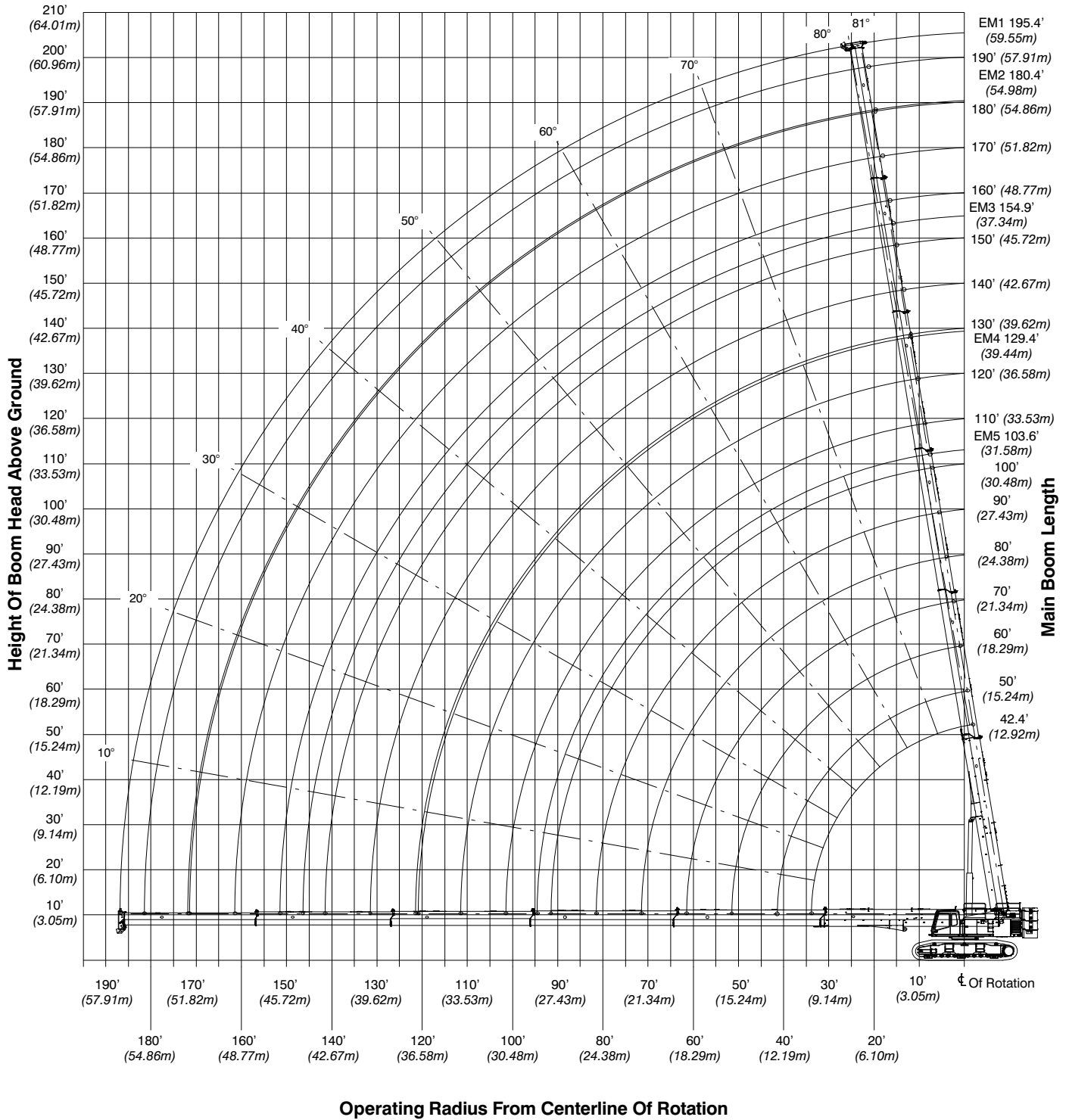

195.4' Main Boom + 10' Fly

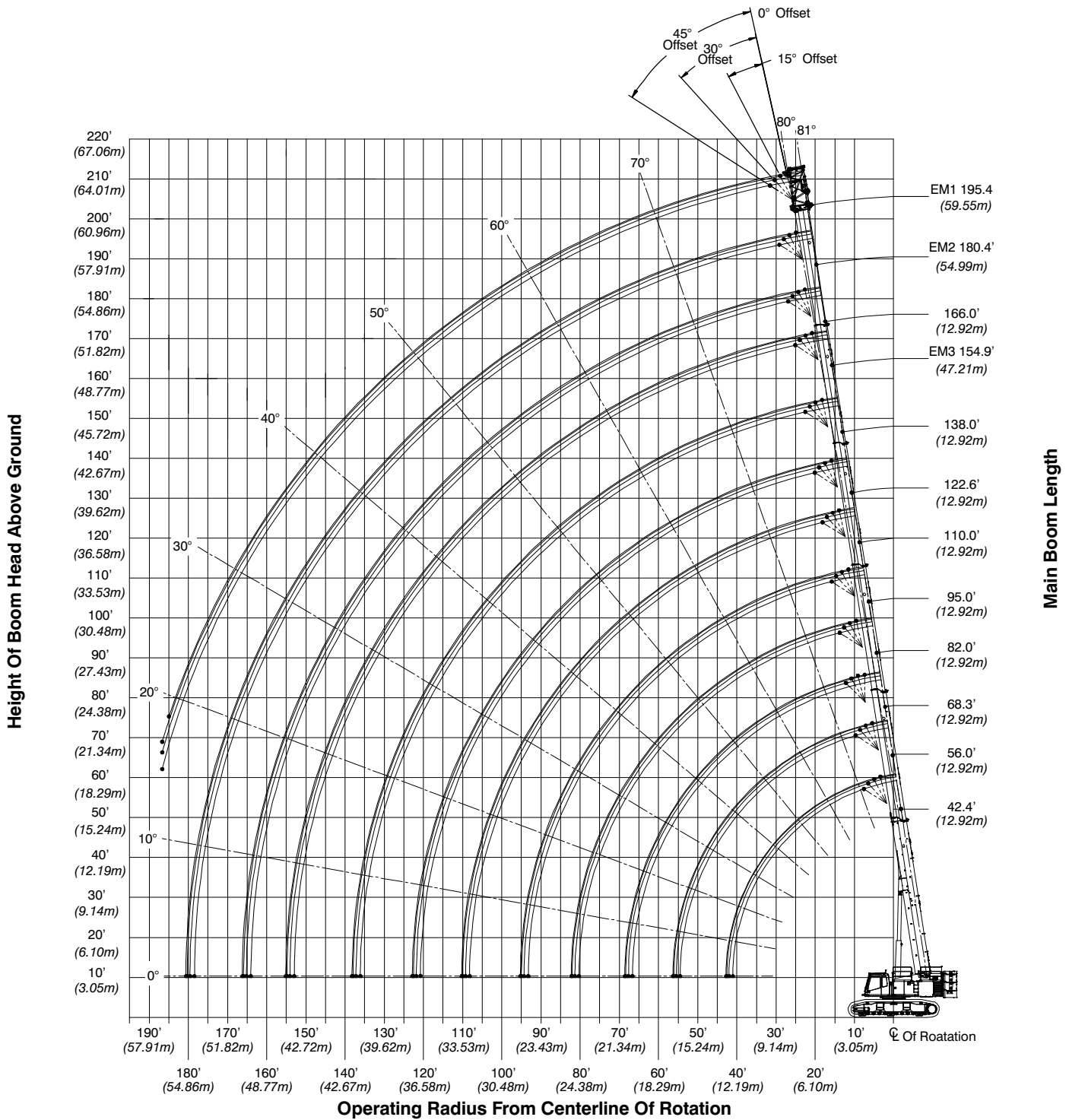

180' Main Boom + 10, 31-55' Fly

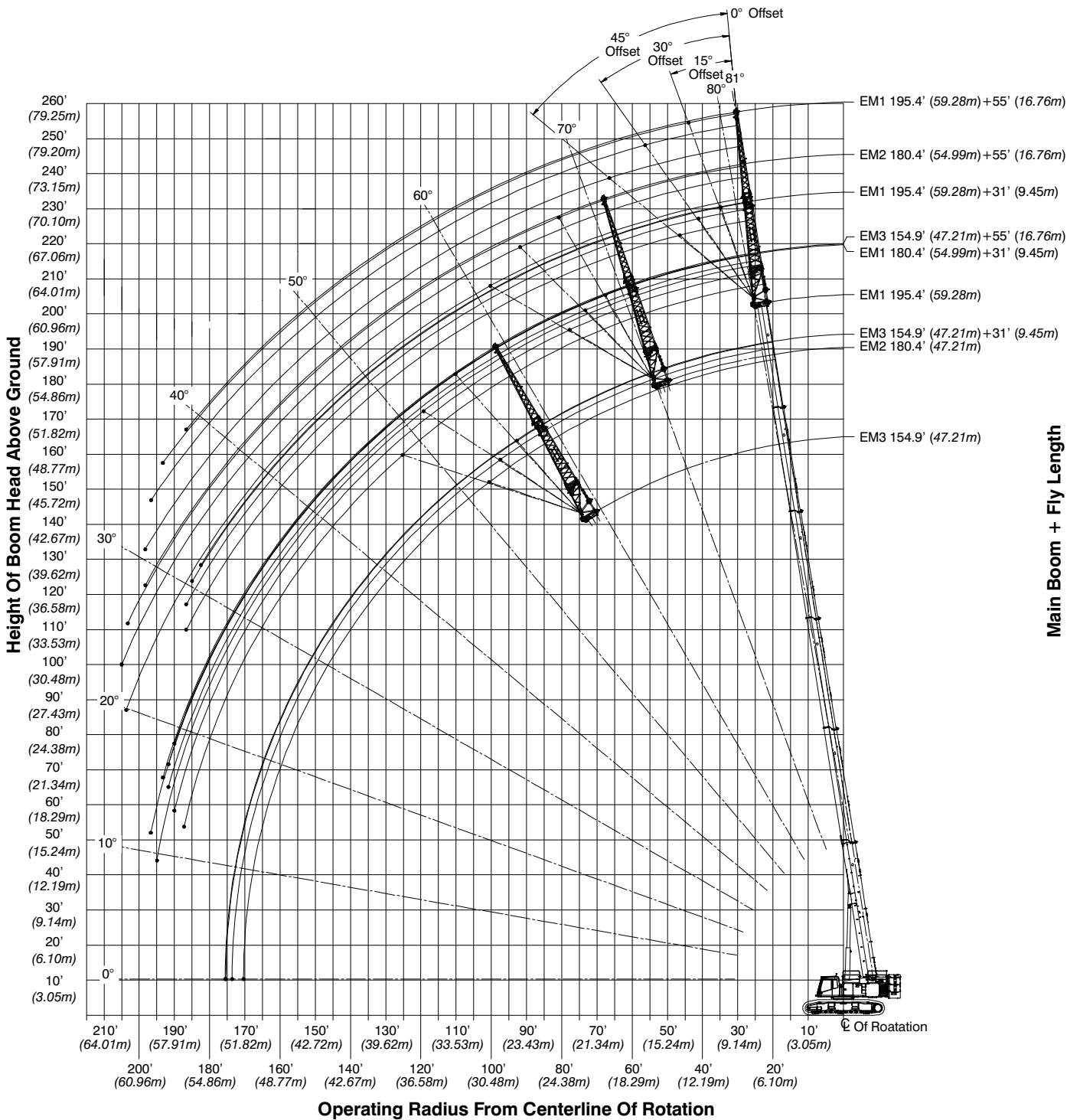

Main Boom Load Charts – Standard

Main Boom Lift Capacity Chart - 360° Rotation - Fully Extended Tracks ABCD+A [82,000lb (37 194kg) Counterweight] [All capacities are listed in lbs]												
Load Radius (ft)	Main Boom - EM1 Boom Mode											Load Radius (ft)
	Boom Length - ft											
	42	56	71	86	101	116	132	147	163	179	195	
8	280,000											8
9	270,700											9
10	259,500	81,300	61,800									10
12	227,100	81,300	61,800									12
15	181,800	81,300	61,800	79,000								15
20	134,700	81,300	61,800	70,000	50,900	38,500						20
25	104,000	81,300	61,800	62,000	50,900	38,500	32,500					25
30	77,100	81,300	59,500	55,500	46,100	38,500	32,500	30,500	26,700			30
35		64,300	53,900	50,100	41,700	38,500	32,500	30,500	26,700	24,900		35
40		52,400	48,300	45,700	38,000	38,500	32,500	30,500	26,700	24,900	21,500	40
45		43,900	43,700	41,900	34,900	35,600	31,600	30,500	26,700	24,900	21,500	45
50			39,600	38,700	32,200	32,900	29,200	29,500	26,700	24,900	21,500	50
55			34,400	35,100	29,800	30,500	27,000	27,400	24,900	24,900	21,500	55
60			30,200	31,000	27,800	28,400	25,100	25,400	23,100	24,700	21,500	60
65				27,500	26,000	26,500	23,400	23,700	21,500	23,100	21,500	65
70				24,600	24,400	24,900	21,900	22,200	20,000	21,600	21,500	70
75				22,100	22,600	22,500	20,500	20,700	18,700	20,200	20,200	75
80					20,500	20,400	19,300	19,500	17,500	18,700	18,100	80
85					18,600	18,500	18,200	18,000	16,400	17,200	16,500	85
90					17,100	17,000	17,000	16,000	15,400	15,500	14,900	90
95						15,600	15,500	15,100	14,500	14,100	13,500	95
100						14,300	14,200	13,800	13,500	12,800	12,200	100
105						13,100	13,100	12,700	12,300	11,700	11,100	105
110							12,000	11,600	11,300	10,600	10,100	110
115							11,100	10,700	10,300	9,700	9,100	115
120							10,200	9,800	9,500	8,800	8,300	120
125								9,000	8,700	8,000	7,500	125
130								8,300	8,000	7,300	6,800	130
135								7,700	7,300	6,700	6,100	135
140									6,700	6,100	5,500	140
145									6,200	5,500	4,900	145
150									5,600	5,000	4,400	150
155										4,500	3,900	155
160										4,000	3,500	160
165										3,600	3,100	165
170										3,300	2,700	170
175											2,300	175
180											2,000	180
185											1,700	185

This material is supplied for reference use only. Operator must refer to in-cab Crane Rating Manual and Operator's Manual to determine allowable crane lifting capacities and assembly and operating procedures.

Main Boom Lift Capacity Chart - 360° Rotation - Fully Extended Tracks ABCD+A [82,000lb (37 194kg) Counterweight] [All capacities are listed in lbs]												
Load Radius (ft)	Main Boom - EM2 Boom Mode											Load Radius (ft)
	Boom Length - ft											
	42.4	56.0	68.3	82.0	95.0	110.0	122.6	138.0	151.1	166.0	180.4	
8	280,000											8
9	270,700											9
10	259,500	81,300	75,900									10
12	227,100	81,300	75,900									12
15	181,800	81,300	75,900	82,900								15
20	134,700	81,300	75,900	74,300	60,100	48,100						20
25	104,000	81,300	71,200	65,600	54,800	48,100	37,700					25
30	77,100	81,300	63,800	58,800	49,100	48,100	37,700	35,900	32,000			30
35		64,300	57,800	53,100	44,400	44,500	37,700	35,900	32,000	30,400	26,400	35
40		52,400	52,900	48,400	40,500	40,600	36,600	35,900	32,000	30,400	26,400	40
45		43,900	45,900	44,400	37,100	37,300	33,600	33,600	31,000	30,400	26,400	45
50			39,200	40,100	34,300	34,500	31,000	31,000	28,500	30,300	26,400	50
55			34,100	34,800	31,800	31,900	28,700	28,700	26,400	28,200	26,400	55
60				30,700	29,600	29,700	26,700	26,700	24,500	26,200	26,400	60
65				27,200	27,700	27,700	24,900	24,900	22,700	24,500	25,500	65
70				24,300	24,800	24,800	23,300	23,200	21,200	23,000	22,600	70
75					22,300	22,300	21,800	21,800	19,800	20,800	20,200	75
80					20,200	20,200	20,100	19,700	18,600	18,700	18,100	80
85					18,400	18,300	18,300	17,800	17,400	17,000	16,500	85
90						16,800	16,800	16,400	16,100	15,400	14,900	90
95						15,300	15,300	14,900	14,600	14,000	13,400	95
100						14,100	14,000	13,600	13,300	12,700	12,200	100
105							12,900	12,500	12,200	11,500	11,000	105
110							11,800	11,400	11,100	10,500	10,000	110
115								10,500	10,200	9,600	9,000	115
120								9,600	9,300	8,700	8,200	120
125								8,900	8,600	7,900	7,400	125
130									7,900	7,200	6,700	130
135									7,200	6,500	6,000	135
140									6,600	5,900	5,400	140
145										4,900	4,900	145
150										4,400	4,300	150
155											3,900	155
160											3,400	160
165											3,000	165
170											2,600	170

This material is supplied for reference use only. Operator must refer to in-cab Crane Rating Manual and Operator's Manual to determine allowable crane lifting capacities and assembly and operating procedures.

Main Boom Lift Capacity Chart - 360° Rotation - Fully Extended Tracks ABCD+A [82,000lb (37 194kg) Counterweight] [All capacities are listed in lbs]										
Load Radius (ft)	Main Boom - EM3 Boom Mode									Load Radius (ft)
	Boom Length - ft									
	42.4	55.5	69.5	84.0	97.1	112.0	125.6	141.0	154.9	
8	280,000									8
9	270,700									9
10	259,500	81,200	80,700							10
12	227,100	81,200	80,700							12
15	181,800	81,200	80,700	79,700						15
20	134,700	81,200	80,700	79,700	70,800	65,500				20
25	104,000	81,200	80,700	79,700	62,500	59,700	53,300			25
30	77,100	81,200	80,700	79,700	55,800	53,400	47,700	50,000	38,800	30
35		64,200	65,900	66,100	50,300	48,100	43,000	45,500	38,800	35
40		52,300	53,900	54,200	45,700	43,700	39,000	41,500	38,800	40
45		43,800	45,300	45,700	41,800	40,000	35,600	38,200	38,800	45
50			38,700	39,100	38,500	36,800	32,700	35,800	36,500	50
55			33,600	33,900	34,200	33,800	30,100	32,700	32,000	55
60			29,400	29,700	29,900	29,600	27,900	28,500	27,900	60
65				26,300	26,500	26,100	25,900	25,100	24,500	65
70				23,400	23,500	23,200	23,000	22,200	21,600	70
75				20,900	21,100	20,700	20,500	19,700	19,200	75
80					18,900	18,600	18,400	17,600	17,100	80
85					17,200	16,900	16,700	15,900	15,500	85
90						15,200	15,000	14,300	13,900	90
95						13,800	13,600	12,900	12,400	95
100						12,500	12,300	11,600	11,100	100
105							11,200	10,400	10,000	105
110							10,100	9,400	9,000	110
115							9,200	8,500	8,000	115
120								7,600	7,200	120
125								6,800	6,400	125
130								6,100	5,700	130
135									5,100	135
140									4,500	140
145									3,900	145

This material is supplied for reference use only. Operator must refer to in-cab Crane Rating Manual and Operator's Manual to determine allowable crane lifting capacities and assembly and operating procedures.

Main Boom Lift Capacity Chart - 360° Rotation - Fully Extended Tracks ABCD+A [82,000lb (37 194kg) Counterweight] [All capacities are listed in lbs]								
Load Radius (ft)	Main Boom - EM4 Boom Mode							Load Radius (ft)
	Boom Length - ft							
	42.4	55.5	69.5	84.4	100.1	116.0	129.4	
8	280,000							8
9	270,700							9
10	259,500	81,200	80,700					10
12	227,100	81,200	80,700					12
15	181,800	81,200	80,700	79,900				15
20	134,700	81,200	80,700	79,900	79,200	75,400		20
25	104,000	81,200	80,700	79,900	79,200	75,400	63,800	25
30	77,100	81,200	80,700	79,900	77,800	75,400	61,300	30
35		64,200	65,900	66,100	65,500	64,300	55,100	35
40		52,300	53,900	54,200	53,700	52,500	49,700	40
45		43,800	45,300	45,700	45,200	44,100	43,400	45
50			38,700	39,100	38,700	37,600	36,900	50
55			33,600	33,900	33,600	32,600	31,900	55
60			29,400	29,700	29,400	28,500	27,800	60
65				26,300	25,900	25,000	24,400	65
70				23,400	23,000	22,100	21,500	70
75				20,900	20,500	19,600	19,100	75
80					18,400	17,500	17,100	80
85					16,700	15,800	15,300	85
90					15,000	14,200	13,600	90
95						12,800	12,200	95
100						11,500	10,900	100
105						10,400	9,800	105
110							8,800	110
115							7,800	115
120							7,000	120

This material is supplied for reference use only. Operator must refer to in-cab Crane Rating Manual and Operator's Manual to determine allowable crane lifting capacities and assembly and operating procedures.

**Main Boom Lift Capacity Chart - 360° Rotation - Fully Extended Tracks
ABCD+A [82,000lb (37 194kg) Counterweight]
[All capacities are listed in lbs]**

Load Radius (ft)	Main Boom - EM5 Boom Mode					Load Radius (ft)
	Boom Length - ft					
	42.4	56.4	71.3	87.0	103.6	
8	280,000					8
9	270,700					9
10	259,500	168,500	157,800			10
12	227,100	168,500	157,800			12
15	181,800	168,500	147,700	120,000		15
20	134,700	137,600	127,300	110,700	93,500	20
25	104,000	107,500	108,400	97,300	88,200	25
30	77,100	80,400	81,400	81,000	77,900	30
35		63,200	64,500	64,100	62,900	35
40		51,500	52,600	52,400	51,400	40
45		42,800	44,100	44,000	42,900	45
50			37,500	37,400	36,400	50
55			32,400	32,300	31,400	55
60			28,200	28,100	27,300	60
65				24,700	23,800	65
70				21,800	20,900	70
75				19,300	18,500	75
80					16,500	80
85					14,700	85
90					13,000	90

This material is supplied for reference use only. Operator must refer to in-cab Crane Rating Manual and Operator's Manual to determine allowable crane lifting capacities and assembly and operating procedures.

Fly Attachment Load Charts – Standard

Jib Boom Lift Capacity Chart - 360° Rotation - Fully Extended Tracks ABCD+A [82,000lb (37 194kg) Counterweight Main Boom EM2 + 10' Offset Fly [All capacities are listed in lbs]													
Radius (ft)	Boom Length (ft)												Radius (ft)
	42.4				56				68.3				
	0°	15°	30°	45°	0°	15°	30°	45°	0°	15°	30°	45°	
10.0	71,600	71,600	71,600	62,700	71,600	71,600	71,600		71,500				10.0
12.0	71,600	71,600	70,200	61,700	71,600	71,600	71,600	62,700	71,500	71,500			12.0
15.0	71,600	71,600	66,700	59,900	71,600	71,600	70,400	61,700	71,500	71,500	71,500	62,500	15.0
20.0	71,600	71,600	62,700	57,200	71,600	71,600	65,900	59,400	71,500	67,700	63,800	60,500	20.0
25.0	71,600	66,600	60,100	54,800	71,600	71,600	62,700	57,200	63,100	60,000	57,000	54,700	25.0
30.0	71,600	62,700	57,100	53,200	71,600	68,500	61,100	55,200	56,200	53,400	51,100	49,400	30.0
35.0	63,200	60,600	55,200		65,400	62,800	58,500	53,700	50,300	48,100	46,300	45,000	35.0
40.0	51,600	52,000			53,700	54,100	54,500	52,700	45,500	43,800	42,400	41,800	40.0
45.0					45,100	45,500	45,800		41,800	40,500	39,400	38,700	45.0
50.0					38,600	38,900	39,100		38,500	37,400	36,600	36,000	50.0
55.0					33,500	33,700			34,600	34,700	34,100		55.0
60.0									30,400	30,600	30,800		60.0
65.0									27,000	27,100			65.0
70.0													70.0
75.0													75.0
80.0													80.0
85.0													85.0
90.0													90.0
95.0													95.0
100.0													100.0
105.0													105.0
110.0													110.0

This material is supplied for reference use only. Operator must refer to in-cab Crane Rating Manual and Operator's Manual to determine allowable crane lifting capacities and assembly and operating procedures.

Jib Boom Lift Capacity Chart - 360° Rotation - Fully Extended Tracks
ABCD+A [82,000lb (37 194kg) Counterweight
Main Boom EM2 + 10' Offset Fly
 [All capacities are listed in lbs]

Radius (ft)	Boom Length (ft)												Radius (ft)
	82				95				110				
	0°	15°	30°	45°	0°	15°	30°	45°	0°	15°	30°	45°	
10.0													10.0
12.0													12.0
15.0	71,400	71,400											15.0
20.0	70,000	66,700	63,900	61,100	59,700	57,600	55,700		48,100				20.0
25.0	61,700	59,200	57,000	55,300	52,400	50,800	49,300	48,200	48,100	48,100	48,100		25.0
30.0	54,600	52,600	51,000	49,600	46,600	45,300	44,200	43,300	47,300	46,300	45,400	44,700	30.0
35.0	48,900	47,300	46,000	45,000	41,800	41,200	40,300	39,600	42,600	41,800	41,400	40,800	35.0
40.0	44,200	42,900	41,900	41,600	38,200	37,400	36,700	36,100	39,000	38,300	37,800	37,300	40.0
45.0	40,800	39,700	38,900	38,300	34,800	34,100	33,600	33,100	35,600	35,100	34,600	34,200	45.0
50.0	37,400	36,500	35,800	35,400	31,900	31,400	30,900	30,600	32,700	32,200	31,900	31,600	50.0
55.0	34,500	33,800	33,200	32,900	29,400	29,000	28,600	28,300	30,200	29,800	29,500	29,200	55.0
60.0	30,800	31,100	31,000	30,700	27,300	26,900	26,600	26,400	27,900	27,600	27,400	27,200	60.0
65.0	27,300	27,500	27,700		25,300	25,000	24,800	24,600	26,000	25,700	25,500	25,400	65.0
70.0	24,400	24,600	24,700		23,700	23,400	23,200	23,100	24,200	24,000	23,900	23,700	70.0
75.0	22,000	22,100	22,200		22,200	22,000	21,800		22,000	22,200	22,300	22,300	75.0
80.0	19,900	20,000			20,100	20,200	20,300		19,900	20,000	20,200	20,300	80.0
85.0					18,200	18,400	18,500		18,000	18,200	18,300		85.0
90.0					16,700	16,800			16,500	16,700	16,800		90.0
95.0					15,300				15,100	15,200	15,300		95.0
100.0									13,800	13,900	14,000		100.0
105.0									12,700	12,800			105.0
110.0									11,700				110.0

This material is supplied for reference use only. Operator must refer to in-cab Crane Rating Manual and Operator's Manual to determine allowable crane lifting capacities and assembly and operating procedures.

Jib Lift Capacity Chart - 360° Rotation - Fully Extended Tracks ABCD+A [82,000lb (37 194kg) Counterweight Main Boom EM2 + 10' Offset Fly [All capacities are listed in lbs]													
Load Radius (ft)	Boom Length (ft)												Load Radius (ft)
	122.6				138				151.1				
	0°	15°	30°	45°	0°	15°	30°	45°	0°	15°	30°	45°	
25.0	37,700												25.0
30.0	37,700	37,700	37,700	37,700	35,800	35,900			30,100	30,600			30.0
35.0	37,700	37,700	37,700	37,300	35,800	35,900	35,900	35,900	30,100	30,600	32,000		35.0
40.0	35,300	34,800	34,400	34,000	35,500	35,100	34,700	34,500	30,100	30,600	32,000	32,000	40.0
45.0	32,200	31,800	31,500	31,200	32,400	32,100	31,800	31,600	29,900	29,700	29,500	29,400	45.0
50.0	29,500	29,200	28,900	28,700	29,800	29,500	29,300	29,100	27,400	27,300	27,100	27,000	50.0
55.0	27,200	26,900	26,700	26,600	27,400	27,200	27,100	26,900	25,200	25,100	25,000	24,900	55.0
60.0	25,200	25,000	24,800	24,600	25,400	25,200	25,100	25,000	23,300	23,200	23,100	23,100	60.0
65.0	23,400	23,200	23,000	22,900	23,500	23,400	23,300	23,200	21,500	21,500	21,400	21,400	65.0
70.0	21,700	21,600	21,500	21,400	21,900	21,800	21,700	21,700	20,300	20,200	20,200	20,100	70.0
75.0	20,600	20,500	20,400	20,300	20,700	20,600	20,600	20,500	18,900	18,800	18,800	18,800	75.0
80.0	19,300	19,200	19,100	19,100	19,100	19,300	19,300	19,200	17,600	17,600	17,500	17,500	80.0
85.0	17,800	18,000	18,000	17,900	17,500	17,700	17,600	17,800	16,400	16,400	16,400	16,400	85.0
90.0	16,400	16,500	16,700	16,700	15,900	16,000	16,200	16,300	15,400	15,400	15,400	15,400	90.0
95.0	14,900	15,100	15,200		14,400	14,600	14,700	14,800	14,100	14,200	14,400	14,400	95.0
100.0	13,700	13,800	13,900		13,200	13,300	13,400	13,500	12,800	13,000	13,100	13,200	100.0
105.0	12,500	12,600	12,700		12,000	12,200	12,300	12,300	11,700	11,800	11,900	12,000	105.0
110.0	11,500	11,600	11,600		11,000	11,100	11,200		10,600	10,800	10,900	11,000	110.0
115.0	10,600	10,600			10,100	10,200	10,200		9,700	9,800	9,900	10,000	115.0
120.0	9,700	9,800			9,200	9,300	9,400		8,900	9,000	9,100		120.0
125.0					8,400	8,500	8,600		8,100	8,200	8,300		125.0
130.0					7,700	7,800			7,400	7,500	7,500		130.0
135.0					7,100	7,200			6,700	6,800	6,900		135.0
140.0									6,100	6,200			140.0
145.0									5,600	5,600			145.0
150.0									5,100				150.0
155.0													155.0
160.0													160.0
165.0													165.0
170.0													170.0
175.0													175.0
180.0													180.0

This material is supplied for reference use only. Operator must refer to in-cab Crane Rating Manual and Operator's Manual to determine allowable crane lifting capacities and assembly and operating procedures.

Jib Lift Capacity Chart - 360° Rotation - Fully Extended Tracks
ABCD+A [82,000lb (37 194kg) Counterweight
Main Boom EM2 + 10' Offset Fly
 [All capacities are listed in lbs]

Load Radius (ft)	Boom Length (ft)								Load Radius (ft)
	166				180.4				
	0°	15°	30°	45°	0°	15°	30°	45°	
25.0									25.0
30.0									30.0
35.0	26,700	27,100			23,500				35.0
40.0	26,700	27,100	28,500	29,000	23,500	24,000			40.0
45.0	26,700	27,100	28,500	29,000	23,500	24,000	25,200	25,900	45.0
50.0	26,700	27,100	28,500	28,400	23,500	24,000	25,200	25,900	50.0
55.0	26,700	26,700	26,500	26,300	23,500	24,000	25,200	25,900	55.0
60.0	25,000	24,800	24,600	24,500	23,500	24,000	25,200	25,600	60.0
65.0	23,200	23,100	23,000	22,800	23,500	24,000	24,100	24,000	65.0
70.0	21,600	21,500	21,400	21,300	21,800	22,200	22,400	22,500	70.0
75.0	20,000	20,300	20,200	20,200	19,400	19,700	20,000	20,200	75.0
80.0	17,900	18,200	18,400	18,600	17,600	17,600	17,800	18,000	80.0
85.0	16,400	16,600	16,800	17,000	15,800	16,000	16,200	16,400	85.0
90.0	14,800	15,000	15,200	15,300	14,200	14,400	14,600	14,700	90.0
95.0	13,300	13,500	13,700	13,800	12,700	13,000	13,100	13,300	95.0
100.0	12,100	12,300	12,400	12,500	11,500	11,700	11,800	12,000	100.0
105.0	10,900	11,100	11,300	11,400	10,300	10,500	10,700	10,800	105.0
110.0	9,900	10,100	10,200	10,300	9,300	9,500	9,600	9,800	110.0
115.0	9,000	9,100	9,300	9,300	8,400	8,600	8,700	8,800	115.0
120.0	8,200	8,300	8,400	8,500	7,600	7,700	7,800	7,900	120.0
125.0	7,400	7,500	7,600	7,700	6,800	6,900	7,100	7,100	125.0
130.0	6,700	6,800	6,900		6,100	6,200	6,300	6,400	130.0
135.0	6,000	6,100	6,200		5,500	5,600	5,700	5,700	135.0
140.0	5,400	5,500	5,600		4,900	5,000	5,100		140.0
145.0	4,900	5,000	5,000		4,300	4,400	4,500		145.0
150.0	4,400	4,400	4,500		3,800	3,900	4,000		150.0
155.0	3,900	4,000			3,300	3,400	3,500		155.0
160.0	3,500	3,500			2,900	2,900	3,000		160.0
165.0	3,100				2,500	2,500			165.0
170.0					2,100	2,100			170.0
175.0					1,700	1,800			175.0
180.0					1,400				180.0

This material is supplied for reference use only. Operator must refer to in-cab Crane Rating Manual and Operator's Manual to determine allowable crane lifting capacities and assembly and operating procedures.

Jib Boom Lift Capacity Chart - 360° Rotation - Fully Extended Tracks ABCD+A [82,000lb (37 194kg) Counterweight Main Boom EM2 + 31' Offset Fly [All capacities are listed in lbs]													
Radius (ft)	Boom Length (ft)												Radius (ft)
	42.4				68.3				95.0				
	0°	15°	30°	45°	0°	15°	30°	45°	0°	15°	30°	45°	
15.0	35,800	32,100			35,700								15.0
20.0	35,800	29,300			35,700	31,000			33,700				20.0
25.0	32,500	27,000	23,400		35,700	29,200			33,100				25.0
30.0	29,500	25,100	22,100	20,100	34,100	27,600	23,400		32,500	28,200			30.0
35.0	27,000	23,500	21,000	19,400	31,800	26,100	22,500	20,200	32,000	27,100	23,100		35.0
40.0	24,900	22,100	20,200	18,900	29,800	24,800	21,600	19,700	31,400	26,100	22,400	20,200	40.0
45.0	23,100	20,900	19,400	18,500	28,000	23,700	20,900	19,300	30,400	25,200	21,800	19,800	45.0
50.0	21,500	19,900	18,800	18,100	26,400	22,700	20,400	18,900	28,500	24,300	21,300	19,500	50.0
55.0	20,200	19,100	18,400		24,900	21,800	19,800	18,600	26,200	23,500	20,900	19,200	55.0
60.0	19,100	18,500	18,000		23,600	21,000	19,300	18,300	24,200	22,800	20,400	18,900	60.0
65.0					22,400	20,300	18,900	18,100	22,400	21,800	20,000	18,700	65.0
70.0					21,400	19,700	18,600	18,000	20,900	20,700	19,600	18,500	70.0
75.0					20,500	19,100	18,300		19,900	19,400	19,000	18,300	75.0
80.0					19,700	18,700	18,000		18,600	18,200	17,900	17,700	80.0
85.0					18,900	18,300			17,500	17,200	16,900	16,800	85.0
90.0					17,600				16,500	16,200	16,000	15,900	90.0
95.0									15,500	15,300	15,200		95.0
100.0									14,700	14,500	14,400		100.0
105.0									13,600	13,800	13,700		105.0
110.0									12,600	12,800			110.0
115.0									11,700	11,800			115.0
120.0													120.0
125.0													125.0
130.0													130.0
135.0													135.0
140.0													140.0
145.0													145.0
150.0													150.0
155.0													155.0
160.0													160.0
165.0													165.0
170.0													170.0
175.0													175.0
180.0													180.0
185.0													185.0
190.0													190.0

This material is supplied for reference use only. Operator must refer to in-cab Crane Rating Manual and Operator's Manual to determine allowable crane lifting capacities and assembly and operating procedures.

Jib Boom Lift Capacity Chart - 360° Rotation - Fully Extended Tracks
ABCD+A [82,000lb (37 194kg) Counterweight
Main Boom EM2 + 31' Offset Fly
 [All capacities are listed in lbs]

Radius (ft)	Boom Length (ft)												Radius (ft)
	122.6				151.1				180.4				
	0°	15°	30°	45°	0°	15°	30°	45°	0°	15°	30°	45°	
15.0													15.0
20.0													20.0
25.0													25.0
30.0	28,600												30.0
35.0	28,400	26,600			17,300								35.0
40.0	28,200	25,900			17,300								40.0
45.0	27,900	25,300	22,100		17,300	17,800			14,400				45.0
50.0	27,500	24,700	21,600	19,800	17,300	17,800	18,200		14,400				50.0
55.0	25,200	24,100	21,200	19,500	17,300	17,800	18,200		14,400	14,500			55.0
60.0	23,300	22,800	20,900	19,300	17,300	17,800	18,200	19,400	14,400	14,500			60.0
65.0	21,600	21,200	20,600	19,100	17,300	17,800	18,200	19,300	14,400	14,500	15,000		65.0
70.0	20,400	20,100	19,800	18,900	17,300	17,800	18,200	19,000	14,400	14,500	15,000	15,800	70.0
75.0	19,000	18,800	18,600	18,400	17,300	17,800	17,700	17,700	14,400	14,500	15,000	15,800	75.0
80.0	17,800	17,600	17,400	17,300	16,600	16,600	16,600	16,600	14,400	14,500	15,000	15,800	80.0
85.0	16,600	16,500	16,400	16,300	15,400	15,500	15,500	15,500	14,400	14,500	15,000	15,800	85.0
90.0	15,600	15,500	15,400	15,300	14,400	14,500	14,500	14,600	14,400	14,500	15,000	15,800	90.0
95.0	14,700	14,600	14,500	14,500	13,500	13,600	13,600	13,700	13,000	13,700	14,300	14,800	95.0
100.0	13,800	13,800	13,700	13,700	12,600	12,700	12,800	12,800	11,800	12,400	13,000	13,400	100.0
105.0	13,000	13,000	13,000	12,900	11,800	11,900	12,000	12,100	10,600	11,200	11,700	12,100	105.0
110.0	11,900	12,300	12,300	12,200	10,900	11,200	11,300	11,300	9,600	10,200	10,600	11,000	110.0
115.0	11,000	11,300	11,500	11,600	10,000	10,400	10,600	10,700	8,700	9,200	9,600	9,900	115.0
120.0	10,200	10,400	10,600		9,200	9,500	9,800	10,000	7,800	8,300	8,700	9,000	120.0
125.0	9,400	9,600	9,700		8,400	8,700	9,000	9,200	7,000	7,500	7,900	8,100	125.0
130.0	8,700	8,900	9,000		7,700	8,000	8,200	8,400	6,300	6,800	7,100	7,300	130.0
135.0	8,000	8,200			7,000	7,300	7,500	7,600	5,700	6,100	6,400	6,600	135.0
140.0	7,400	7,500			6,400	6,700	6,900		5,100	5,500	5,700	5,900	140.0
145.0	5,700				5,900	6,100	6,200		4,500	4,900	5,100	5,300	145.0
150.0					5,300	5,500	5,700		4,000	4,300	4,600	4,700	150.0
155.0					4,900	5,000	5,100		3,500	3,800	4,000	4,100	155.0
160.0					4,400	4,600			3,100	3,400	3,500	3,600	160.0
165.0					4,000	4,100			2,700	2,900	3,100		165.0
170.0					3,600	3,700			2,300	2,500	2,600		170.0
175.0									1,900	2,100	2,200		175.0
180.0									1,600	1,700	1,800		180.0
185.0									1,300	1,400	1,500		185.0
190.0										1,100			190.0

This material is supplied for reference use only. Operator must refer to in-cab Crane Rating Manual and Operator's Manual to determine allowable crane lifting capacities and assembly and operating procedures.

Jib Boom Lift Capacity Chart - 360° Rotation - Fully Extended Tracks
ABCD+A [82,000lb (37 194kg) Counterweight
Main Boom EM2 + 55' Offset Fly
 [All capacities are listed in lbs]

Radius (ft)	Boom Length (ft)												Radius (ft)
	42.4				68.3				95.0				
	0°	15°	30°	45°	0°	15°	30°	45°	0°	15°	30°	45°	
15.0	23,100												15.0
20.0	20,800				21,400								20.0
25.0	18,600	15,200			20,300				19,400				25.0
30.0	16,800	14,000			19,000				18,700				30.0
35.0	15,300	13,000			17,600	14,000			18,000				35.0
40.0	14,100	12,100	10,600		16,400	13,200			17,400	13,800			40.0
45.0	13,000	11,300	10,100		15,300	12,500	10,600		16,700	13,200			45.0
50.0	12,100	10,700	9,600	8,800	14,300	11,900	10,200		15,800	12,600	10,600		50.0
55.0	11,300	10,100	9,200	8,500	13,400	11,300	9,800	8,800	15,000	12,100	10,300		55.0
60.0	10,500	9,600	8,800	8,200	12,600	10,800	9,500	8,600	14,300	11,700	9,900	8,800	60.0
65.0	9,900	9,100	8,500	8,000	12,000	10,300	9,200	8,400	13,600	11,200	9,700	8,600	65.0
70.0	9,400	8,700	8,200	7,900	11,300	9,900	8,900	8,200	13,000	10,800	9,400	8,400	70.0
75.0	8,900	8,400	8,000	7,800	10,800	9,500	8,600	8,000	12,400	10,500	9,200	8,300	75.0
80.0	8,400	8,100	7,800		10,300	9,200	8,400	7,900	11,900	10,100	8,900	8,200	80.0
85.0	8,000	7,900			9,800	8,900	8,200	7,800	11,400	9,800	8,700	8,100	85.0
90.0					9,400	8,600	8,000	7,800	10,900	9,500	8,500	8,000	90.0
95.0					9,000	8,300	7,900	7,800	10,500	9,200	8,400	7,900	95.0
100.0					8,600	8,100	7,800		10,100	9,000	8,200	7,800	100.0
105.0					8,300	7,900	7,800		9,700	8,700	8,100	7,800	105.0
110.0					8,000	7,800			9,400	8,500	8,000	7,700	110.0
115.0									9,100	8,300	7,900	7,700	115.0
120.0									8,800	8,200	7,800		120.0
125.0									8,500	8,000	7,800		125.0
130.0									8,300	7,900	7,700		130.0
135.0									8,000	7,800			135.0
140.0									7,900	7,800			140.0
145.0													145.0
150.0													150.0
155.0													155.0
160.0													160.0
165.0													165.0
170.0													170.0
175.0													175.0
180.0													180.0
185.0													185.0
190.0													190.0
195.0													195.0
200.0													200.0

This material is supplied for reference use only. Operator must refer to in-cab Crane Rating Manual and Operator's Manual to determine allowable crane lifting capacities and assembly and operating procedures.

Jib Boom Lift Capacity Chart - 360° Rotation - Fully Extended Tracks
ABCD+A [82,000lb (37 194kg) Counterweight
Main Boom EM2 + 55' Offset Fly
 [All capacities are listed in lbs]

Radius (ft)	Boom Length (ft)												Radius (ft)
	122.6				151.1				180.4				
	0°	15°	30°	45°	0°	15°	30°	45°	0°	15°	30°	45°	
15.0													15.0
20.0													20.0
25.0													25.0
30.0													30.0
35.0	15,500												35.0
40.0	15,500												40.0
45.0	15,500				12,400								45.0
50.0	15,500	13,000			12,400				10,700				50.0
55.0	15,400	12,600			12,400	12,600			10,700				55.0
60.0	15,100	12,200	10,200		12,400	12,400			10,700				60.0
65.0	14,600	11,800	10,000		12,400	12,100			10,700				65.0
70.0	14,100	11,500	9,700	8,600	12,400	11,800	10,000		10,700	10,900			70.0
75.0	13,500	11,100	9,500	8,500	12,400	11,500	9,800		10,700	10,900			75.0
80.0	13,000	10,800	9,300	8,400	12,400	11,200	9,600	8,500	10,700	10,900	9,800		80.0
85.0	12,600	10,500	9,100	8,300	12,400	11,000	9,400	8,400	10,700	10,900	9,600		85.0
90.0	12,200	10,200	8,900	8,100	12,400	10,700	9,200	8,300	10,700	10,900	9,500	8,400	90.0
95.0	11,700	9,900	8,800	8,100	12,400	10,500	9,100	8,200	10,700	10,800	9,300	8,300	95.0
100.0	11,300	9,700	8,600	8,000	12,200	10,200	8,900	8,100	10,700	10,600	9,200	8,200	100.0
105.0	11,000	9,500	8,500	7,900	11,500	10,000	8,800	8,000	10,700	10,400	9,000	8,200	105.0
110.0	10,600	9,200	8,300	7,800	10,800	9,800	8,700	8,000	10,200	10,200	8,900	8,100	110.0
115.0	10,300	9,000	8,200	7,800	10,100	9,600	8,500	7,900	9,300	10,000	8,800	8,000	115.0
120.0	10,000	8,800	8,100	7,800	9,500	9,400	8,400	7,900	8,400	9,300	8,700	8,000	120.0
125.0	9,700	8,700	8,000	7,700	9,000	9,200	8,300	7,800	7,600	8,500	8,600	7,900	125.0
130.0	9,300	8,500	7,900	7,700	8,300	8,600	8,200	7,800	6,900	7,700	8,400	7,900	130.0
135.0	8,700	8,300	7,900	7,700	7,600	8,100	8,100	7,700	6,300	7,000	7,600	7,800	135.0
140.0	8,000	8,200	7,800	7,700	7,000	7,500	7,800	7,700	5,600	6,300	6,900	7,300	140.0
145.0	7,500	7,800	7,800		6,400	6,900	7,300	7,500	5,100	5,700	6,300	6,600	145.0
150.0	7,000	7,200	7,400		5,900	6,400	6,700	6,900	4,600	5,200	5,700	6,000	150.0
155.0	6,500	6,700	6,800		5,400	5,800	6,100	6,300	4,100	4,600	5,100	5,400	155.0
160.0	6,000	6,200			5,000	5,300	5,600	5,700	3,600	4,200	4,600	4,800	160.0
165.0	5,600	5,800			4,500	4,900	5,100		3,200	3,700	4,100	4,300	165.0
170.0					4,100	4,500	4,700		2,800	3,300	3,600	3,800	170.0
175.0					3,800	4,000	4,200		2,400	2,900	3,200	3,300	175.0
180.0					3,400	3,700	3,800		2,100	2,500	2,800	2,900	180.0
185.0					3,100	3,300			1,800	2,100	2,400	2,500	185.0
190.0					2,800	3,000			1,500	1,800	2,000		190.0
195.0									1,200	1,500	1,700		195.0
200.0										1,200	1,300		200.0

This material is supplied for reference use only. Operator must refer to in-cab Crane Rating Manual and Operator's Manual to determine allowable crane lifting capacities and assembly and operating procedures.

Main Boom Load Charts – Metric

Main Boom Lift Capacity Chart - 360° Rotation - Fully Extended Tracks ABCD+A 37 194kg Counterweight [All capacities are listed in kg]												
Load Radius (m)	Main Boom - EM1 Boom Mode											Load Radius (m)
	Boom Length (m)											
	12.9	17.1	21.7	26.2	30.8	35.4	40.1	44.8	49.7	54.6	59.6	
2.5	125 000											2.5
3.0	118 250	36 850	28 000									3.0
3.5	107 300	36 850	28 000									3.5
4.0	94 150	36 850	28 000									4.0
4.5	83 600	36 850	28 000	35 800								4.5
5.0	75 050	36 850	28 000	35 000								5.0
6.0	61 900	36 850	28 000	32 000	23 050	17 450						6.0
7.0	52 300	36 850	28 000	29 500	23 050	17 450						7.0
8.0	43 350	36 850	28 000	27 300	22 650	17 450	14 800					8.0
9.0	35 750	36 850	27 250	25 400	21 100	17 450	14 800					9.0
10.0	30 100	32 100	25 500	23 750	19 750	17 450	14 800	13 900	12 100			10.0
12.0		24 250	22 200	20 950	17 450	17 450	14 800	13 900	12 100	11 250	9 750	12.0
14.0		19 150	19 450	18 750	15 600	15 900	14 150	13 900	12 100	11 250	9 750	14.0
16.0			16 650	16 900	14 050	14 350	12 750	12 900	11 750	11 250	9 750	16.0
18.0			13 950	14 350	12 750	13 050	11 550	11 700	10 600	11 250	9 750	18.0
20.0				12 250	11 700	11 950	10 550	10 650	9 650	10 400	9 750	20.0
22.0				10 600	10 750	10 800	9 650	9 750	8 800	9 550	9 750	22.0
24.0					9 450	9 450	8 900	9 000	8 050	8 700	8 400	24.0
26.0					8 350	8 300	8 200	8 100	7 400	7 750	7 450	26.0
28.0					7 450	7 400	7 400	7 250	6 850	6 800	6 500	28.0
30.0						6 600	6 600	6 400	6 250	6 000	5 700	30.0
32.0						5 900	5 900	5 700	5 550	5 250	5 000	32.0
34.0							5 300	5 100	4 950	4 650	4 400	34.0
36.0							4 750	4 550	4 400	4 100	3 850	36.0
38.0								4 100	3 950	3 650	3 400	38.0
40.0								3 650	3 500	3 200	2 950	40.0
42.0								3 300	3 150	2 850	2 600	42.0
44.0									2 800	2 500	2 250	44.0
46.0									2 500	2 200	1 950	46.0
48.0										1 900	1 650	48.0
50.0										1 650	1 400	50.0
52.0											1 150	52.0
54.0											950	54.0
56.0											750	56.0

This material is supplied for reference use only. Operator must refer to in-cab Crane Rating Manual and Operator's Manual to determine allowable crane lifting capacities and assembly and operating procedures.

Main Boom Lift Capacity Chart - 360° Rotation - Fully Extended Tracks												
ABCD+A 37 194kg												
[All capacities are listed in kg]												
Load Radius (m)	Main Boom - EM2 Boom Mode											Load Radius (m)
	Boom Length (m)											
	12.9	17.1	20.8	25.0	29.0	33.5	37.4	42.1	46.1	50.6	55.0	
2.5	125 000											2.5
3.0	118 250	36 850	34 400									3.0
3.5	107 300	36 850	34 400									3.5
4.0	94 150	36 850	34 400									4.0
4.5	83 600	36 850	34 400	37 600								4.5
5.0	75 050	36 850	34 400	37 150								5.0
6.0	61 900	36 850	34 400	33 950	27 250	21 800						6.0
7.0	52 300	36 850	33 850	31 250	26 050	21 800						7.0
8.0	43 350	36 850	31 350	28 900	24 150	21 800	17 100					8.0
9.0	35 750	36 850	29 200	26 900	22 500	21 800	17 100	16 250	14 500			9.0
10.0	30 100	32 100	27 350	25 150	21 000	21 050	17 100	16 250	14 500	13 750		10.0
12.0		24 250	24 250	22 200	18 600	18 650	16 800	16 250	14 500	13 750	11 950	12.0
14.0		19 150	20 100	19 800	16 600	16 650	15 000	15 000	13 850	13 750	11 950	14.0
16.0			16 450	16 900	14 950	15 050	13 500	13 500	12 450	13 250	11 950	16.0
18.0			13 800	14 200	13 600	13 650	12 250	12 250	11 250	12 050	11 950	18.0
20.0				12 100	12 350	12 350	11 200	11 200	10 250	11 050	11 400	20.0
22.0				10 450	10 700	10 700	10 250	10 250	9 350	10 000	9 750	22.0
24.0					9 350	9 350	9 350	9 150	8 550	8 700	8 400	24.0
26.0					8 250	8 200	8 200	8 000	7 900	7 700	7 400	26.0
28.0						7 300	7 300	7 150	7 000	6 750	6 500	28.0
30.0						6 500	6 500	6 300	6 200	5 900	5 700	30.0
32.0							5 800	5 600	5 500	5 200	5 000	32.0
34.0							5 200	5 000	4 900	4 600	4 350	34.0
36.0								4 500	4 350	4 050	3 850	36.0
38.0								4 000	3 900	3 600	3 350	38.0
40.0									3 450	3 150	2 950	40.0
42.0									3 100	2 800	2 550	42.0
44.0										2 450	2 200	44.0
46.0										2 150	1 900	46.0
48.0											1 600	48.0
50.0											1 350	50.0
52.0											1 150	52.0

This material is supplied for reference use only. Operator must refer to in-cab Crane Rating Manual and Operator's Manual to determine allowable crane lifting capacities and assembly and operating procedures.

Main Boom Lift Capacity Chart - 360° Rotation - Fully Extended Tracks ABCD+A 37 194kg Counterweight [All capacities are listed in kg]										
Load Radius (m)	Main Boom - EM3 Boom Mode									Load Radius (m)
	Boom Length (m)									
	12.9	16.9	21.2	25.6	29.6	34.1	38.3	43.0	47.2	
2.5	125 000									2.5
3.0	118 250	36 800	36 600							3.0
3.5	107 300	36 800	36 600							3.5
4.0	94 150	36 800	36 600							4.0
4.5	83 600	36 800	36 600	36 150						4.5
5.0	75 050	36 800	36 600	36 150						5.0
6.0	61 900	36 800	36 600	36 150	32 350	29 700				6.0
7.0	52 300	36 800	36 600	36 150	29 750	28 400				7.0
8.0	43 350	36 800	36 600	36 150	27 500	26 300	23 500			8.0
9.0	35 750	36 800	36 600	36 150	25 550	24 450	21 850	22 650	17 550	9.0
10.0	30 100	32 000	32 850	32 950	23 850	22 800	20 400	21 500	17 550	10.0
12.0		24 200	25 000	25 200	20 950	20 050	17 900	19 100	17 550	12.0
14.0		19 100	19 850	20 050	18 700	17 850	15 900	17 050	17 550	14.0
16.0			16 250	16 400	16 550	16 000	14 250	15 400	15 650	16.0
18.0			13 550	13 750	13 850	13 750	12 800	13 250	13 000	18.0
20.0				11 650	11 800	11 650	11 550	11 200	10 950	20.0
22.0				10 000	10 100	10 000	9 900	9 550	9 300	22.0
24.0					8 750	8 650	8 550	8 200	8 000	24.0
26.0					7 700	7 550	7 450	7 150	6 950	26.0
28.0						6 600	6 500	6 250	6 000	28.0
30.0						5 800	5 700	5 400	5 200	30.0
32.0							5 000	4 750	4 500	32.0
34.0							4 400	4 100	3 900	34.0
36.0								3 600	3 350	36.0
38.0								3 100	2 900	38.0
40.0								2 700	2 500	40.0
42.0									2 100	42.0
44.0									1 800	44.0

This material is supplied for reference use only. Operator must refer to in-cab Crane Rating Manual and Operator's Manual to determine allowable crane lifting capacities and assembly and operating procedures.

Main Boom Lift Capacity Chart - 360° Rotation - Fully Extended Tracks ABCD+A 37 194kg Counterweight [All capacities are listed in kg]								
Load Radius (m)	Main Boom - EM4 Boom Mode							Load Radius (m)
	Boom Length (m)							
	12.9	16.9	21.2	25.7	30.5	35.4	39.4	
2.5	125 000							2.5
3.0	118 250	36 800	36 600					3.0
3.5	107 300	36 800	36 600					3.5
4.0	94 150	36 800	36 600					4.0
4.5	83 600	36 800	36 600	36 200				4.5
5.0	75 050	36 800	36 600	36 200				5.0
6.0	61 900	36 800	36 600	36 200	35 900	34 200		6.0
7.0	52 300	36 800	36 600	36 200	35 900	34 200		7.0
8.0	43 350	36 800	36 600	36 200	35 900	34 200	29 000	8.0
9.0	35 750	36 800	36 600	36 200	35 650	34 200	27 800	9.0
10.0	30 100	32 000	32 850	32 950	32 650	32 050	26 200	10.0
12.0		24 200	25 000	25 200	24 900	24 400	22 850	12.0
14.0		19 100	19 850	20 050	19 900	19 400	19 050	14.0
16.0			16 250	16 400	16 250	15 800	15 600	16.0
18.0			13 550	13 750	13 600	13 200	12 900	18.0
20.0				11 650	11 550	11 150	10 900	20.0
22.0				10 000	9 900	9 500	9 250	22.0
24.0					8 550	8 150	7 900	24.0
26.0					7 450	7 100	6 850	26.0
28.0						6 150	5 900	28.0
30.0						5 350	5 100	30.0
32.0						4 650	4 400	32.0
34.0							3 800	34.0
36.0							3 300	36.0

This material is supplied for reference use only. Operator must refer to in-cab Crane Rating Manual and Operator's Manual to determine allowable crane lifting capacities and assembly and operating procedures.

Main Boom Lift Capacity Chart - 360° Rotation - Fully Extended Tracks						
ABCD+A 37 194kg Counterweight						
[All capacities are listed in kg]						
Load Radius (m)	Main Boom - EM5 Boom Mode					Load Radius (m)
	Boom Length (m)					
	42.4	56.4	71.3	87.0	103.6	
2.5	125 000					2.5
3.0	118 250	76 400	71 550			3.0
3.5	107 300	76 400	71 550			3.5
4.0	94 150	76 400	71 250			4.0
4.5	83 600	76 400	67 500	54 400		4.5
5.0	75 050	76 350	64 150	54 400		5.0
6.0	61 900	63 300	58 250	50 650	42 400	6.0
7.0	52 300	53 750	53 400	46 450	42 200	7.0
8.0	43 350	45 100	45 500	42 800	38 700	8.0
9.0	35 750	37 350	37 850	37 700	35 700	9.0
10.0	30 100	31 700	32 200	32 050	31 450	10.0
12.0		23 900	24 400	24 350	23 800	12.0
14.0		18 800	19 300	19 300	18 850	14.0
16.0			15 700	15 700	15 350	16.0
18.0			13 050	13 000	12 650	18.0
20.0				10 950	10 600	20.0
22.0				9 300	8 950	22.0
24.0					7 650	24.0
26.0					6 550	26.0
28.0					5 600	28.0

This material is supplied for reference use only. Operator must refer to in-cab Crane Rating Manual and Operator's Manual to determine allowable crane lifting capacities and assembly and operating procedures.

Jib Boom Lift Capacity Chart - 360° Rotation - Fully Extended Tracks
ABCD+A 37 194kg Counterweight
Main Boom EM2 + 3.0m Offset Fly
 [All capacities are listed in kg]

Radius (m)	Boom Length (m)												Radius (m)
	12.9				17.1				20.8				
	0°	15°	30°	45°	0°	15°	30°	45°	0°	15°	30°	45°	
3.0	32 450	32 450	32 450	28 450	32 450	32 450	32 450		32 450				3.0
3.5	32 450	32 450	32 150	28 150	32 450	32 450	32 450	28 450	32 450	32 450			3.5
4.0	32 450	32 450	31 200	27 650	32 450	32 450	32 450	28 400	32 450	32 450			4.0
4.5	32 450	32 450	30 350	27 250	32 450	32 450	32 050	28 000	32 450	32 450	32 450	28 400	4.5
5.0	32 450	32 450	29 600	26 800	32 450	32 450	31 300	27 650	32 450	32 450	31 900	28 100	5.0
6.0	32 450	32 450	28 450	26 050	32 450	32 450	30 000	27 000	32 450	30 950	29 200	27 500	6.0
7.0	32 450	31 200	27 950	25 250	32 450	32 450	28 850	26 400	30 200	28 450	27 100	25 950	7.0
8.0	32 450	29 600	26 900	24 600	32 450	32 450	28 450	25 700	27 950	26 400	25 150	24 200	8.0
9.0	32 450	28 450	26 000	24 150	32 450	31 250	27 850	25 100	25 800	24 500	23 450	22 600	9.0
10.0	31 450	28 100	25 350	23 900	31 850	29 700	27 000	24 600	23 950	22 800	21 900	21 250	10.0
12.0	24 000	24 150	24 300		24 900	25 150	25 300	23 950	20 900	20 100	19 450	18 950	12.0
14.0					19 850	20 000	20 150		18 750	18 100	17 600	17 300	14.0
16.0					16 250	16 400			16 750	16 350	16 000	15 800	16.0
18.0									14 100	14 200	14 300		18.0
20.0									12 050	12 150			20.0
22.0													22.0
24.0													24.0
26.0													26.0
28.0													28.0
30.0													30.0
32.0													32.0

This material is supplied for reference use only. Operator must refer to in-cab Crane Rating Manual and Operator's Manual to determine allowable crane lifting capacities and assembly and operating procedures.

Jib Boom Lift Capacity Chart - 360° Rotation - Fully Extended Tracks ABCD+A 37 194kg Counterweight Main Boom EM2 + 3.0m Offset Fly [All capacities are listed in kg]														
Radius (m)	Boom Length (m)												Radius (m)	
	25.0				29.0				33.5					
	0°	15°	30°	45°	0°	15°	30°	45°	0°	15°	30°	45°		
3.0														3.0
3.5														3.5
4.0														4.0
4.5	32 400	32 400												4.5
5.0	32 400	32 400												5.0
6.0	32 050	30 550	29 250	27 800	27 250	26 300	25 450		21 800					6.0
7.0	29 250	28 250	27 150	26 250	25 050	24 200	23 500		21 800					7.0
8.0	27 100	26 050	25 100	24 400	23 050	22 350	21 750	21 250	21 800	21 800	21 800			8.0
9.0	25 050	24 150	23 350	22 750	21 350	20 750	20 250	19 800	21 700	21 200	20 800	20 450		9.0
10.0	23 250	22 450	21 800	21 300	19 850	19 350	18 950	18 750	20 200	19 800	19 450	19 150		10.0
12.0	20 300	19 700	19 250	18 950	17 550	17 150	16 800	16 550	17 900	17 600	17 300	17 100		12.0
14.0	18 200	17 700	17 350	17 100	15 550	15 250	15 000	14 800	15 900	15 650	15 450	15 300		14.0
16.0	16 250	15 900	15 650	15 450	13 900	13 650	13 450	13 350	14 250	14 050	13 900	13 750		16.0
18.0	14 300	14 400	14 250	14 100	12 550	12 350	12 200	12 100	12 850	12 700	12 600	12 500		18.0
20.0	12 200	12 300	12 400		11 400	11 250	11 150	11 050	11 700	11 550	11 500	11 400		20.0
22.0	10 600	10 650	10 700		10 450	10 300	10 250	10 200	10 550	10 600	10 500	10 450		22.0
24.0	9 250	9 300			9 350	9 400	9 450		9 250	9 300	9 400	9 400		24.0
26.0					8 250	8 300	8 300		8 100	8 200	8 250			26.0
28.0					7 350	7 350			7 250	7 300	7 350			28.0
30.0									6 450	6 500	6 500			30.0
32.0									5 750	5 800				32.0

This material is supplied for reference use only. Operator must refer to in-cab Crane Rating Manual and Operator's Manual to determine allowable crane lifting capacities and assembly and operating procedures.

Fly Attachment Load Charts – Metric

Jib Lift Capacity Chart - 360° Rotation - Fully Extended Tracks
ABCD+A 37 194kg Counterweight
Main Boom EM2 + 3.0m Offset Fly
 [All capacities are listed in kg]

Load Radius (m)	Boom Length (m)												Load Radius (m)
	37.4				42.1				46.1				
	0°	15°	30°	45°	0°	15°	30°	45°	0°	15°	30°	45°	
8.0	17 100												8.0
9.0	17 100	17 100	17 100	17 100	16 200	16 250			13 650	13 900			9.0
10.0	17 100	17 100	17 100	17 100	16 200	16 250	16 250	16 250	13 650	13 900	14 500		10.0
12.0	16 200	15 950	15 750	15 600	16 200	16 100	15 950	15 800	13 650	13 900	14 500	14 500	12.0
14.0	14 350	14 200	14 050	13 950	14 450	14 350	14 200	14 100	13 350	13 250	13 150	13 100	14.0
16.0	12 850	12 700	12 600	12 500	12 950	12 850	12 750	12 700	11 900	11 850	11 800	11 750	16.0
18.0	11 600	11 500	11 400	11 350	11 650	11 600	11 550	11 500	10 700	10 650	10 650	10 600	18.0
20.0	10 500	10 400	10 350	10 300	10 600	10 500	10 500	10 450	9 650	9 650	9 650	9 600	20.0
22.0	9 550	9 500	9 450	9 450	9 650	9 600	9 550	9 550	8 900	8 900	8 850	8 850	22.0
24.0	8 900	8 850	8 800	8 800	8 900	8 900	8 850	8 850	8 100	8 100	8 100	8 100	24.0
26.0	8 050	8 100	8 100	8 100	7 850	7 950	8 050	8 000	7 400	7 400	7 400	7 400	26.0
28.0	7 150	7 250	7 300	7 350	6 950	7 000	7 100	7 100	6 750	6 800	6 800	6 800	28.0
30.0	6 350	6 400	6 450		6 150	6 200	6 250	6 300	6 000	6 050	6 100	6 150	30.0
32.0	5 700	5 750	5 750		5 450	5 500	5 550	5 600	5 300	5 350	5 400	5 450	32.0
34.0	5 050	5 100	5 150		4 850	4 900	4 950		4 700	4 750	4 800	4 800	34.0
36.0	4 550	4 600			4 300	4 350	4 400		4 150	4 200	4 250		36.0
38.0					3 850	3 900	3 900		3 700	3 750	3 750		38.0
40.0					3 450	3 450			3 250	3 300	3 350		40.0
42.0					3 100				2 900	2 950			42.0
44.0									2 550	2 600			44.0
46.0									2 300				46.0
48.0													48.0
50.0													50.0
52.0													52.0
54.0													54.0

This material is supplied for reference use only. Operator must refer to in-cab Crane Rating Manual and Operator's Manual to determine allowable crane lifting capacities and assembly and operating procedures.

Jib Lift Capacity Chart - 360° Rotation - Fully Extended Tracks ABCD+A 37 194kg Counterweight Main Boom EM2 + 3.0m Offset Fly [All capacities are listed in kg]									
Load Radius (m)	Boom Length (m)								Load Radius (m)
	50.6				55.0				
	0°	15°	30°	45°	0°	15°	30°	45°	
8.0									8.0
9.0									9.0
10.0	12 100								10.0
12.0	12 100	12 350	12 900		10 700	10 900			12.0
14.0	12 100	12 350	12 900	13 200	10 700	10 900	11 450	11 750	14.0
16.0	12 100	12 350	12 500	12 400	10 700	10 900	11 450	11 750	16.0
18.0	11 500	11 400	11 300	11 250	10 700	10 900	11 450	11 750	18.0
20.0	10 450	10 400	10 300	10 250	10 700	10 900	10 850	10 800	20.0
22.0	9 550	9 500	9 450	9 450	9 400	9 550	9 650	9 750	22.0
24.0	8 350	8 500	8 600	8 650	8 050	8 200	8 300	8 400	24.0
26.0	7 350	7 500	7 550	7 650	7 100	7 200	7 300	7 400	26.0
28.0	6 450	6 550	6 600	6 700	6 150	6 250	6 350	6 400	28.0
30.0	5 650	5 750	5 800	5 850	5 400	5 450	5 550	5 600	30.0
32.0	4 950	5 050	5 100	5 150	4 700	4 750	4 850	4 900	32.0
34.0	4 350	4 450	4 500	4 500	4 100	4 150	4 250	4 300	34.0
36.0	3 850	3 900	3 950	4 000	3 550	3 650	3 700	3 750	36.0
38.0	3 350	3 400	3 450	3 500	3 100	3 150	3 200	3 250	38.0
40.0	2 950	3 000	3 050		2 700	2 750	2 800	2 800	40.0
42.0	2 550	2 600	2 650		2 300	2 350	2 400	2 450	42.0
44.0	2 250	2 300	2 300		2 000	2 000	2 050		44.0
46.0	1 950	1 950	2 000		1 650	1 700	1 750		46.0
48.0	1 650	1 700			1 400	1 450	1 450		48.0
50.0	1 400	1 450			1 150	1 200	1 200		50.0
52.0					900	950			52.0
54.0					700	750			54.0

This material is supplied for reference use only. Operator must refer to in-cab Crane Rating Manual and Operator's Manual to determine allowable crane lifting capacities and assembly and operating procedures.

Jib Boom Lift Capacity Chart - 360° Rotation - Fully Extended Tracks
ABCD+A 37 194kg Counterweight
Main Boom EM2 + 9.4m Offset Fly
 [All capacities are listed in kg]

Radius (m)	Boom Length (m)												Radius (m)
	12.9				20.8				29.0				
	0°	15°	30°	45°	0°	15°	30°	45°	0°	15°	30°	45°	
4.5	16 200	14 600			16 150								4.5
5.0	16 200	14 150			16 150								5.0
6.0	16 200	13 350			16 150	14 100			15 350				6.0
7.0	15 350	12 650			16 150	13 550			15 150				7.0
8.0	14 350	12 050	10 450		16 150	13 050			14 950				8.0
9.0	13 500	11 450	10 100	9 150	15 600	12 550	10 650		14 800	12 850			9.0
10.0	12 700	10 950	9 750	8 950	14 900	12 100	10 350	9 300	14 600	12 500	10 600		10.0
12.0	11 400	10 100	9 200	8 600	13 600	11 350	9 850	8 950	14 300	11 900	10 200	9 200	12.0
14.0	10 300	9 400	8 750	8 350	12 550	10 650	9 450	8 700	13 650	11 350	9 850	8 950	14.0
16.0	9 450	8 850	8 400	8 200	11 600	10 100	9 100	8 500	12 400	10 850	9 500	8 750	16.0
18.0	8 750	8 400	8 200		10 800	9 550	8 800	8 350	11 150	10 400	9 300	8 600	18.0
20.0					10 100	9 200	8 550	8 200	10 100	9 800	9 050	8 450	20.0
22.0					9 500	8 800	8 400	8 200	9 350	9 100	8 850	8 300	22.0
24.0					9 000	8 500	8 200		8 600	8 400	8 250	8 150	24.0
26.0					8 550	8 250			7 900	7 750	7 650	7 600	26.0
28.0									7 300	7 200	7 100	7 050	28.0
30.0									6 800	6 700	6 650		30.0
32.0									6 150	6 250	6 200		32.0
34.0									5 550	5 650			34.0
36.0													36.0
38.0													38.0
40.0													40.0
42.0													42.0
44.0													44.0
46.0													46.0
48.0													48.0
50.0													50.0
52.0													52.0
54.0													54.0
56.0													56.0
58.0													58.0

This material is supplied for reference use only. Operator must refer to in-cab Crane Rating Manual and Operator's Manual to determine allowable crane lifting capacities and assembly and operating procedures.

Jib Boom Lift Capacity Chart - 360° Rotation - Fully Extended Tracks ABCD+A 37 194kg Counterweight Main Boom EM2 + 9.4m Offset Fly [All capacities are listed in kg]													
Radius (m)	Boom Length (m)												Radius (m)
	37.4				46.1				55.0				
	0°	15°	30°	45°	0°	15°	30°	45°	0°	15°	30°	45°	
4.5													4.5
5.0													5.0
6.0													6.0
7.0													7.0
8.0													8.0
9.0	12 950												9.0
10.0	12 950				7 850								10.0
12.0	12 800	11 800			7 850				6 500				12.0
14.0	12 650	11 400	10 000	9 100	7 850	8 100			6 500				14.0
16.0	11 950	11 050	9 700	8 900	7 850	8 100	8 300		6 500	6 550			16.0
18.0	10 750	10 500	9 500	8 750	7 850	8 100	8 300	8 750	6 500	6 550			18.0
20.0	9 700	9 550	9 350	8 650	7 850	8 100	8 300	8 750	6 500	6 550	6 800		20.0
22.0	8 950	8 850	8 750	8 550	7 850	8 100	8 300	8 350	6 500	6 550	6 800	7 200	22.0
24.0	8 200	8 100	8 050	7 950	7 650	7 650	7 650	7 650	6 500	6 550	6 800	7 200	24.0
26.0	7 500	7 450	7 400	7 350	6 950	7 000	7 000	7 000	6 500	6 550	6 800	7 200	26.0
28.0	6 900	6 850	6 850	6 800	6 350	6 400	6 400	6 450	6 300	6 550	6 800	7 150	28.0
30.0	6 400	6 350	6 350	6 300	5 850	5 900	5 900	5 950	5 500	5 800	6 050	6 250	30.0
32.0	5 900	5 900	5 850	5 850	5 350	5 400	5 450	5 450	4 800	5 100	5 300	5 500	32.0
34.0	5 300	5 450	5 450	5 450	4 800	5 000	5 000	5 050	4 200	4 450	4 650	4 800	34.0
36.0	4 750	4 850	4 950		4 300	4 500	4 600	4 650	3 700	3 900	4 100	4 250	36.0
38.0	4 250	4 400	4 450		3 800	4 000	4 100	4 150	3 200	3 400	3 600	3 700	38.0
40.0	3 850	3 950	4 000		3 400	3 550	3 650	3 700	2 800	3 000	3 150	3 250	40.0
42.0	3 500	3 550			3 000	3 150	3 250	3 250	2 400	2 600	2 750	2 800	42.0
44.0	3 150				2 700	2 800	2 850		2 100	2 250	2 350	2 400	44.0
46.0					2 400	2 450	2 500		1 750	1 900	2 000	2 100	46.0
48.0					2 100	2 150	2 200		1 500	1 600	1 700	1 750	48.0
50.0					1 850	1 900			1 250	1 350	1 450		50.0
52.0					1 650	1 650			1 000	1 100	1 150		52.0
54.0									800	900	950		54.0
56.0									600	650	700		56.0
58.0										500			58.0

This material is supplied for reference use only. Operator must refer to in-cab Crane Rating Manual and Operator's Manual to determine allowable crane lifting capacities and assembly and operating procedures.

Jib Boom Lift Capacity Chart - 360° Rotation - Fully Extended Tracks ABCD+A 37 194kg Counterweight Main Boom EM2 + 16.7m Offset Fly [All capacities are listed in kg]													
Radius (m)	Boom Length (m)												Radius (m)
	12.9				20.8				29.0				
	0°	15°	30°	45°	0°	15°	30°	45°	0°	15°	30°	45°	
4.5	10 550												4.5
5.0	10 250												5.0
6.0	9 500				9 750								6.0
7.0	8 800				9 400								7.0
8.0	8 250	6 750			9 050				8 750				8.0
9.0	7 700	6 400			8 700				8 500				9.0
10.0	7 250	6 050			8 250	6 500			8 300				10.0
12.0	6 450	5 550	4 850		7 500	6 000			7 900	6 300			12.0
14.0	5 800	5 100	4 500		6 850	5 600	4 800		7 500	5 950			14.0
16.0	5 300	4 700	4 250	3 900	6 300	5 250	4 550		7 000	5 600	4 700		16.0
18.0	4 850	4 400	4 000	3 750	5 800	4 950	4 300	3 900	6 550	5 350	4 550	4 000	18.0
20.0	4 450	4 100	3 850	3 650	5 400	4 650	4 150	3 800	6 150	5 050	4 350	3 900	20.0
22.0	4 150	3 900	3 650	3 550	5 000	4 400	4 000	3 700	5 750	4 850	4 200	3 800	22.0
24.0	3 850	3 700	3 550	3 550	4 700	4 200	3 850	3 600	5 450	4 600	4 050	3 700	24.0
26.0	3 650	3 550			4 400	4 000	3 700	3 550	5 150	4 450	3 950	3 650	26.0
28.0					4 150	3 850	3 650	3 500	4 850	4 250	3 850	3 600	28.0
30.0					3 950	3 700	3 550		4 600	4 100	3 750	3 550	30.0
32.0					3 750	3 600	3 550		4 400	3 950	3 650	3 500	32.0
34.0					3 600	3 550			4 200	3 850	3 600	3 500	34.0
36.0									4 050	3 750	3 550	3 500	36.0
38.0									3 850	3 650	3 550		38.0
40.0									3 700	3 550	3 500		40.0
42.0									3 600	3 500			42.0
44.0													44.0
46.0													46.0
48.0													48.0
50.0													50.0
52.0													52.0
54.0													54.0
56.0													56.0
58.0													58.0
60.0													60.0
62.0													62.0

This material is supplied for reference use only. Operator must refer to in-cab Crane Rating Manual and Operator's Manual to determine allowable crane lifting capacities and assembly and operating procedures.

Jib Boom Lift Capacity Chart - 360° Rotation - Fully Extended Tracks ABCD+A 37 194kg Counterweight Main Boom EM2 + 16.7m Offset Fly [All capacities are listed in kg]													
Radius (m)	Boom Length (m)												Radius (m)
	37.4				46.1				55.0				
	0°	15°	30°	45°	0°	15°	30°	45°	0°	15°	30°	45°	
4.5													4.5
5.0													5.0
6.0													6.0
7.0													7.0
8.0													8.0
9.0													9.0
10.0													10.0
12.0	7 050												12.0
14.0	7 050	6 100			5 650								14.0
16.0	7 050	5 800			5 650				4 850				16.0
18.0	6 850	5 550	4 650		5 650	5 650			4 850				18.0
20.0	6 600	5 350	4 500		5 650	5 450			4 850				20.0
22.0	6 250	5 150	4 400	3 900	5 650	5 300	4 500		4 850	4 950			22.0
24.0	5 950	4 950	4 250	3 800	5 650	5 100	4 350		4 850	4 950			24.0
26.0	5 700	4 750	4 150	3 750	5 650	4 950	4 250	3 800	4 850	4 950	4 350		26.0
28.0	5 450	4 600	4 000	3 700	5 650	4 800	4 150	3 750	4 850	4 950	4 250	3 800	28.0
30.0	5 200	4 450	3 950	3 650	5 600	4 650	4 050	3 700	4 850	4 850	4 200	3 750	30.0
32.0	4 950	4 300	3 850	3 600	5 200	4 550	4 000	3 650	4 850	4 700	4 100	3 700	32.0
34.0	4 750	4 150	3 750	3 550	4 800	4 400	3 900	3 600	4 500	4 600	4 050	3 650	34.0
36.0	4 600	4 050	3 700	3 500	4 400	4 300	3 850	3 550	3 950	4 350	3 950	3 650	36.0
38.0	4 400	3 950	3 650	3 500	4 100	4 150	3 750	3 550	3 500	3 850	3 900	3 600	38.0
40.0	4 150	3 850	3 600	3 500	3 650	3 850	3 700	3 500	3 050	3 400	3 700	3 550	40.0
42.0	3 750	3 750	3 550	3 450	3 300	3 550	3 650	3 500	2 650	3 000	3 250	3 450	42.0
44.0	3 400	3 550	3 500		2 950	3 150	3 350	3 400	2 350	2 650	2 850	3 050	44.0
46.0	3 100	3 250	3 300		2 650	2 850	3 000	3 050	2 000	2 300	2 500	2 650	46.0
48.0	2 850	2 950	2 950		2 350	2 550	2 650	2 700	1 750	2 000	2 200	2 300	48.0
50.0	2 600	2 650			2 100	2 250	2 350		1 500	1 700	1 900	2 000	50.0
52.0					1 850	2 000	2 100		1 250	1 450	1 600	1 700	52.0
54.0					1 650	1 750	1 800		1 050	1 200	1 350	1 400	54.0
56.0					1 450	1 550	1 550		850	1 000	1 100	1 150	56.0
58.0					1 250				650	800	900		58.0
60.0									500	600	700		60.0
62.0											500		62.0

This material is supplied for reference use only. Operator must refer to in-cab Crane Rating Manual and Operator's Manual to determine allowable crane lifting capacities and assembly and operating procedures.

This Page Intentionally Blank

This Page Intentionally Blank

Link-Belt Construction Equipment Company Lexington, Kentucky www.linkbelt.com

®Link-Belt is a registered trademark. Copyright 2015. We are constantly improving our products and therefore reserve the right to change designs and specifications.