



Link-Belt
C R A N E S

TCC 1400

**140 U.S. ton | 127 metric ton
Telescopic Crawler Crane**

- 42.3' - 195.4' | 12.9 - 59.5 m main boom
- 203' | 61.96m main boom tip height
- Six section pin & latch boom
- Remarkable control, reliability & capacity performance
- Unbeatable hydraulic pilot-operated control
- Superior jobsite flexibility
- 20° tilting cab
- Quick mobilization - transports in four or five loads
- Rear view and winch cameras



TCC 1400

140 U.S. ton | 127 metric ton Telescopic Crawler Crane

Standard with:

- Upper guardrail
- Rear view camera
- Winch camera
- Travel and swing alarm
- Cat walks
- Assembly RCL capacity chart on jacks

Built for remarkable control, reliability and capacity performance on any terrain

- 320 hp (239 kW) Cummins QSL Tier 4 Final engine
- Variable displacement piston type main pumps with total horsepower control
- Main hoists powered through piston motors and winch planetary drums grooved for 7/8" (22mm) wire rope
- 22,380 lb (10 151 kg) of line pull
- 537 fpm (163.7 m/min) of winch speed
- Three working gauges
- Multiple counterweight configurations

Roof wiper with opening top hatch

Optional Amber strobe

Optional 360° remote high intensity flood light*

20° tilting cab

Optional front and rear tool boxes

Carbody jacks deploy fast and easily

Greaseless boom

Link-Belt



Excellent access for all routine engine and hydraulic maintenance



- Winch view camera
- Standard hoist drum cable follower and optional third wrap indicator & function kick-out
- Rear view camera
- Upper guard rails
- 6-piece (including carbody) cast modular counterweight
- Remote oil cooler
- Left/right side catwalks
- Lockable compartments
- 36" (914 mm) 3 bar grousers
- Sealed oil-filled idlers upper and lower rollers

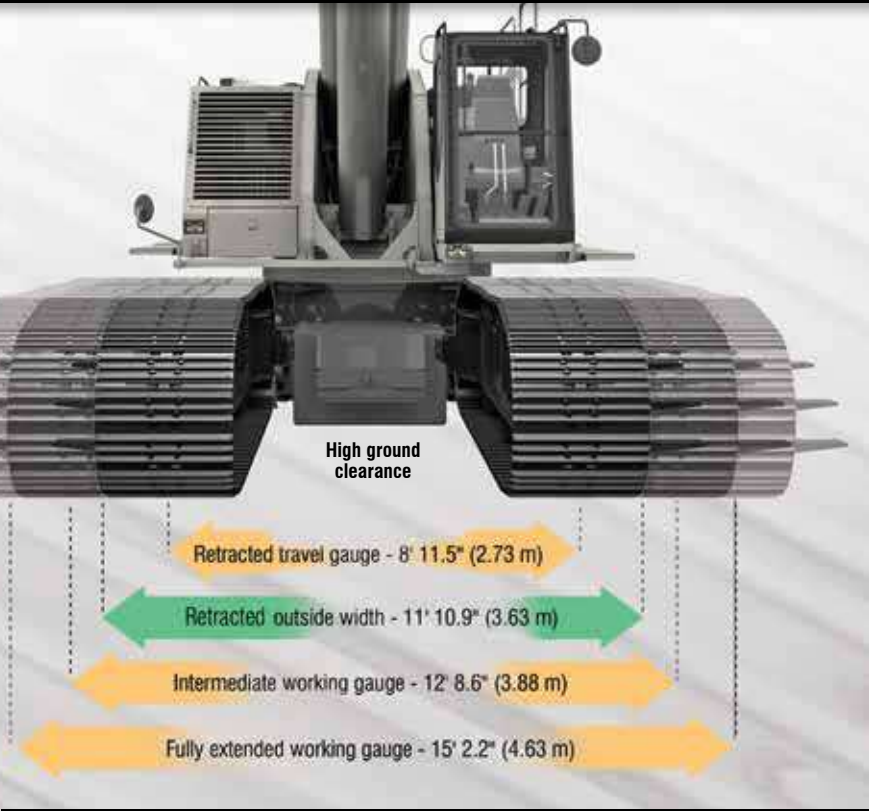

Non-slip safety strips, extended length catwalks, sideframe steps and upper guard rails provide sure-footed access to the crane upper.

Link-Belt has the only greaseless, high-capacity formed booms designed and built in North America!



2 load line lifts charted in all 5 boom modes!

Innovative 10 ft (3.0m) fly is integral to the 3-piece on-board fly options.
 Over 25 tons (22.6 mt) capacity and one-load two-line lift procedures.
 Equipped with two sheaves for up to 4 parts of line.

Pin & latch boom with attachment flexibility

- Ingenious Teflon wear pucks impregnated in the full contact wear pads remove the need for greasing the boom.
- Quick reeve boom head eliminates the need to remove the becket to change the reeving.
- 5 extend modes: EM1-EM5 and standard modes enhance both the structural and stability capacity capability and are fully synchronized for normal operation.
- Manual offset fly: 0°, 15°, 30°, 45°
- No deducts for stowed attachments

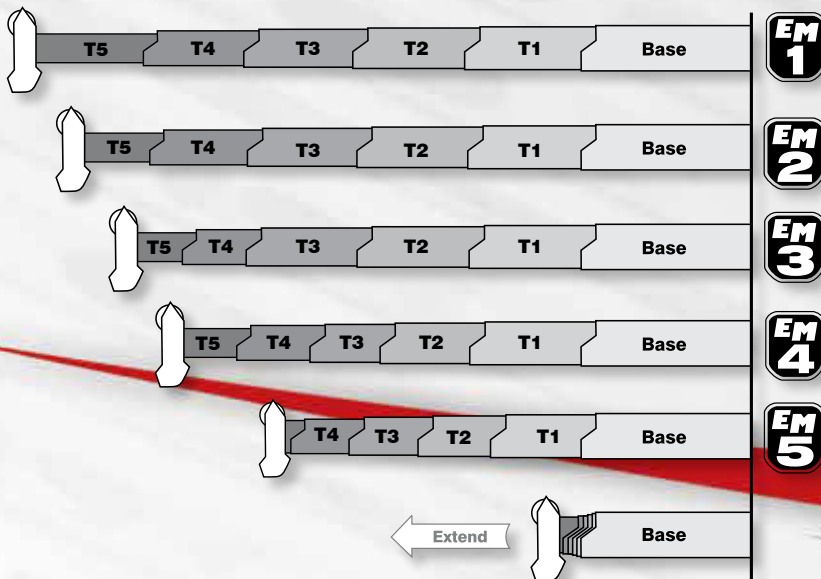

Only 5 Extend Modes!

GREASELESS BOOM!

TEFLON WEAR PADS!



Operator aid features

- Operator settable alarms with function kick-out include left and right slew angle, maximum & minimum boom angle, head height, load radius, boom length, and operator defined area

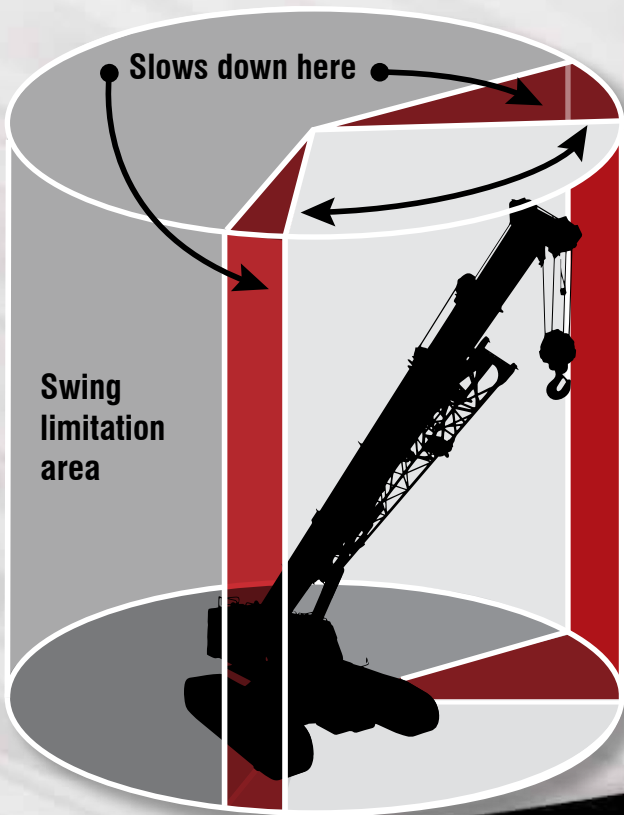

New efficient fly pinning design focuses on ease of assembly/disassembly



Rope keeper maintains travel of rope through sheave

Quick reeve boom head eliminates the need to remove the becket when it becomes necessary to change the reeving



Heavy-duty power for the most demanding jobs

- Low noise, Tier 4 Final Cummins, four stroke diesel with an abundance of horsepower to provide multi-function operation and fast 2.0 mph travel speed. All engine systems are monitored via the on board engine control monitor.
- On-demand, direct drive, high pressure variable displacement piston pumps power the boom hoist function as well as matching front and rear high pressure piston winch motors connected through planetary drives to large diameter grooved drum laggings.
- A dedicated hydraulic swing pump feeds two independent swing drive assemblies with open center free swing, providing a smooth glide feel. Both dynamic and static swing brakes are also offered as standard equipment.
- Travel propel is achieved through individual side frame-mounted, two-speed, high pressure piston motors / travel reduction boxes with integral travel brake.
- Oil is cooled by a remote mounted, hydraulic powered, high capacity cooler.

Total crane operating system

Link-Belt Pulse is the Link-Belt designed total crane operating system. It includes the rated capacity limiter, boom extend mode controller (EMC), self-diagnostic capabilities and continuous monitoring of multiple crane functions and conditions. To aid operators in a safe and efficient operation, its high-resolution, color-intense graphic display provides excellent contrast even in direct sunlight.

Link-Belt PULSE



Highly functional and comfortable cab

- Cab tilt to 20°
- High capacity air-conditioning
- High capacity hot water heating
- Six-way adjustable seat
- LED service monitor screen provides engine performance and critical data using conventional gauge appearance. Second level provides actual digital values, as well as diagnostic information.
- Adjustable armrest console with pilot-operated single-axis or joystick controls
- Hydraulic pilot controls for variable hoist, swing and travel performance
- Fingertip high speed hoist button for front and rear drum
- Rear view and winch view cameras

Telematics. You own the data!

Cellular-based data logging and monitoring system that provides:

- Viewing options for sharing data with distributor and Link-Belt
- Location and operational settings
- Monitor routine maintenance intervals
- Crane and engine monitoring
- Diagnostic and fault codes

Rated capacity limiter light bar



Optional - external



Standard - internal



Courtesy of Crane.Market

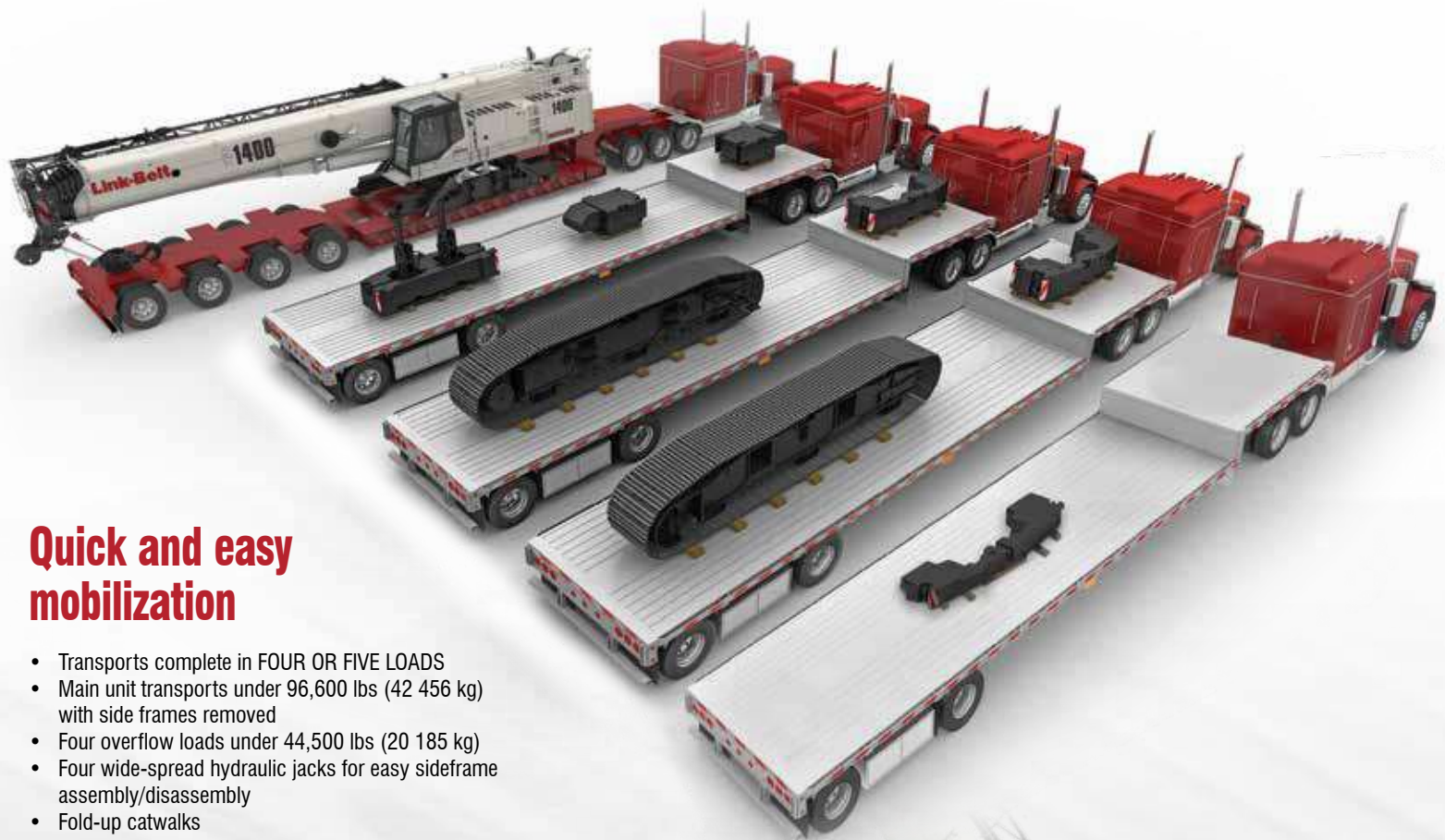

Quick and easy mobilization

- Transports complete in FOUR OR FIVE LOADS
- Main unit transports under 96,600 lbs (42 456 kg) with side frames removed
- Four overflow loads under 44,500 lbs (20 185 kg)
- Four wide-spread hydraulic jacks for easy sideframe assembly/disassembly
- Fold-up catwalks

JUST 5 TRUCKS GETS THE TCC-1400 TO YOUR JOB!

Main transport load: Under 94,600 lbs (42 637 kg)	12' 8" overall transport height on 10" blocks 10' 6" overall width with sideframes removed
1st overflow: 44,000 lbs (19 958.4 kg)	"A" cwtw 19,000 lbs (8 618.4 kg) Two 12,500 lbs (5 670 kg) carbody counterweights
2nd & 3rd overflow: 44,500 lbs each (20 185.2 kg)	28,500 lbs (12 927.6 kg) sideframe 16,000 upper "B/C" cwtw
Fourth overflow: 6,000 lbs each (2721kg)	6,000 (2721) "D" Counterweight

Complete self-load-out and assembly. Link-Belt PULSE RCL monitors capacities on jacks.



Fast, easy counterweight removal





Link-Belt Construction Equipment Company is a leader in the design, manufacture and sales of telescopic and lattice boom cranes with headquarters and manufacturing facilities in Lexington, Kentucky, USA. Link-Belt is committed to the manufacture and service of high quality products that satisfy customers worldwide

Towards that end, Link-Belt has pursued a strategy of growth and investment. It has moved aggressively to seize more global market share by producing a broader range of products and strengthening distribution and personnel around the globe.

Link-Belt is also home to a family of passionate professionals with a legacy of innovation and cutting-edge technology spanning over 140 years. These professionals, in a 740,000 sq. ft. (68 748 m2) manufacturing facility and with a culture of continuous innovation, have pushed Link-Belt to be the most modern crane manufacturer in North America.

Your crane investment is always protected... with your Link-Belt distributor.

When you invest in a Link-Belt crane, you invest in a legacy of outstanding customer support dating back to 1874. The ultimate value of a machine begins with state-of-the-art design and quality manufacturing, but it is the excellent Link-Belt distributor product support that determines its long term value. This philosophy has earned Link-Belt cranes the enviable position of traditionally commanding some of the highest resale prices in the industry.

"... to be
recognized
as a

leader in
**customer
service &
satisfaction."**

— The Link-Belt Vision

Link-Belt® *Preferred*

As a member of Link-Belt Cranes user's group, you will have access to:

- A comprehensive online library of all parts, service and operator manuals for YOUR crane
- Interactive, live groundbearing calculations for YOUR crane
- Plus a vast array of information on new products, services and special offerings
- Online access to recommended spare parts lists, filter, lube and key lists plus maintenance information and more
- No annual fee or charges to access your crane information

Link-Belt was born because our founding father understood the importance of replacement parts.

William Dana Everett

Building on that principal...

- Trained technical specialists
- Faster and more efficient customer service
- State of the art computer information systems
- 24 hours a day, 7 days a week
- 72,000 Sq. Ft. Parts Distribution Center
- All parts in stock ship the same business day

**Link-Belt
CRANES
GENUINE
PARTS**



©Link-Belt is a registered trademark. Copyright 2017
All rights reserved. We reserve the right to change
designs and specifications at any time. Litho in U.S.A.
2/17 1640 #4503

Link-Belt
CRANES

Lexington, Kentucky | www.linkbelt.com

Courtesy of Crane.Market