

Technical data
Hydraulic crawler crane

HS 8100 HD
Litronic®



LIEBHERR

Courtesy of Crane.Market

Dimensions

Basic machine with undercarriage

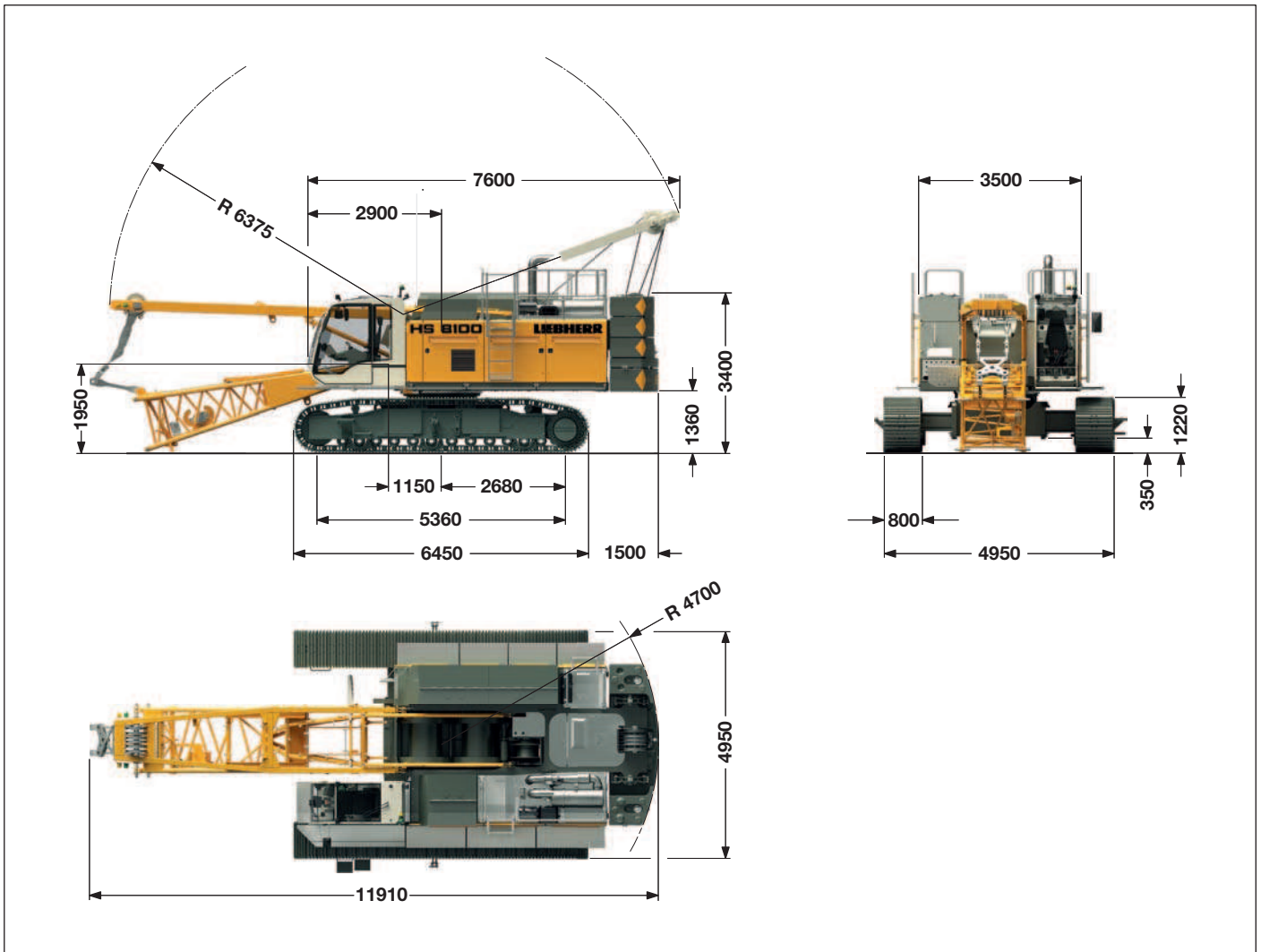

Operating weight

The operating weight includes the basic machine with HD undercarriage, 2 main winches 250 kN including wire ropes (90 m) and 11 m main boom, consisting of A-frame, boom foot (5.5 m) and boom head (5.5 m), 26.3 t basic counterweight, 800 mm 3-web grousers and 50 t hook block.

Total weight _____ approx. 89 t

Ground pressure

Ground bearing pressure _____ 1.04 kg/cm²

Equipment

Main boom (No. 1311.xx) max. length _____ 68 m
 Fixed jib (No. 0806.xx) _____ 11 m - 32 m
 Modular designed equipment for operation as crane, with dragline or clamshell.

For dragline operation, a rotating fairlead is fitted into the boom foot. This minimizes the rope angle to drum, which results in lower rope wear.

Remarks

1. The lifting capacities stated are valid for lifting operation only (corresponding with crane classification according to F.E.M. 1.001, crane group A1).
2. Crane standing on firm, horizontal ground.
3. The weight of the lifting device (hoisting ropes, hook block, shackle etc.) must be deducted from the gross lifting capacity to obtain a net lifting value.
4. Additional equipment on boom (e.g. boom walkways, auxiliary jib) must be deducted to get the net lifting capacity.
5. For max. wind speed please refer to lift chart in operator's cab or manual.
6. Working radii are measured from centre of swing and under load.
7. The lifting capacities are valid for 360 degrees of swing.
8. Calculation of stability under load is based on ISO 4305 Table 1 + 2, tipping angle 4°.
9. The structures are calculated according to F.E.M. 1.001 - 1998 (EN 13001-2 / 2004).

Transport dimensions and weights

Basic machine and boom (No. 1311.22)

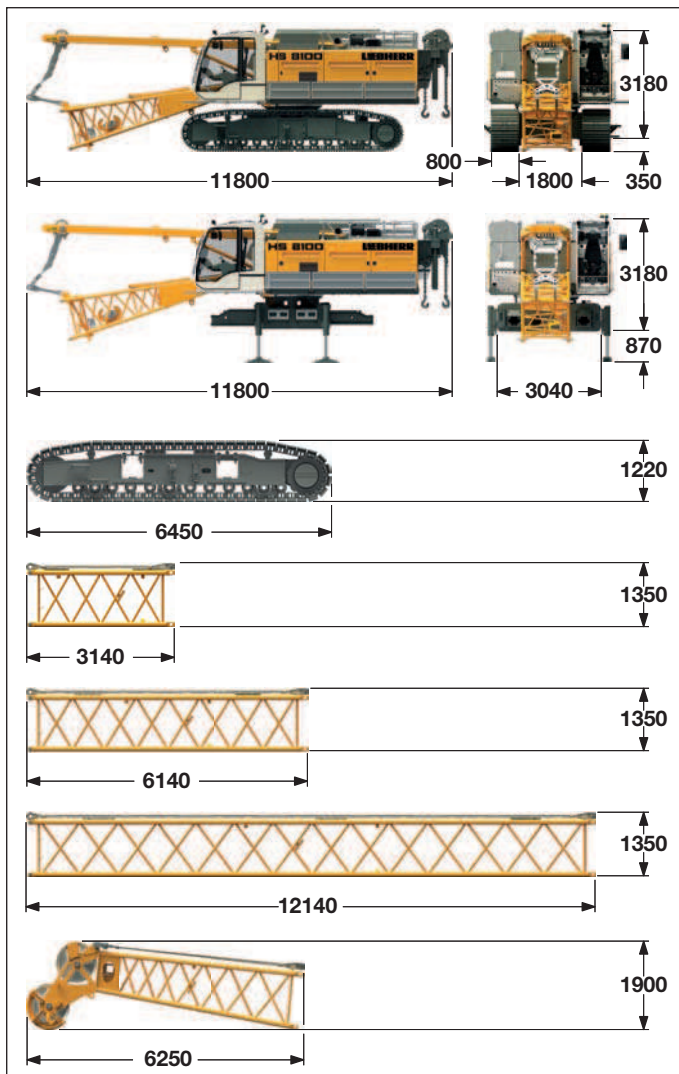

*) Including pendant ropes

Basic machine

with HD undercarriage, boom foot (No. 1311.22), A-frame, 2x 250 kN winches including wire ropes (90 m), without basic counterweight

Width	3500 mm
Weight	59550 kg

Basic machine

with boom foot (No. 1311.22), A-frame, 2x 250 kN winches including wire ropes (90 m), without basic counterweight and crawlers

Width	3500 mm
Weight	40230 kg

Crawler

3-web grousers	800 mm
Width	915 mm
Weight	9650 kg

Boom section (No. 1311.22)

3 m

Width	1430 mm
Weight*	470 kg

Boom section (No. 1311.22)

6 m

Width	1430 mm
Weight*	730 kg

Boom section (No. 1311.21)

12 m

Width	1430 mm
Weight*	1260 kg

Boom head¹⁾ (No. 1311.22)

Width	1430 mm
Weight*	1610 kg

1) Polyamide sheaves

Fixed jib (No. 0806.xx)

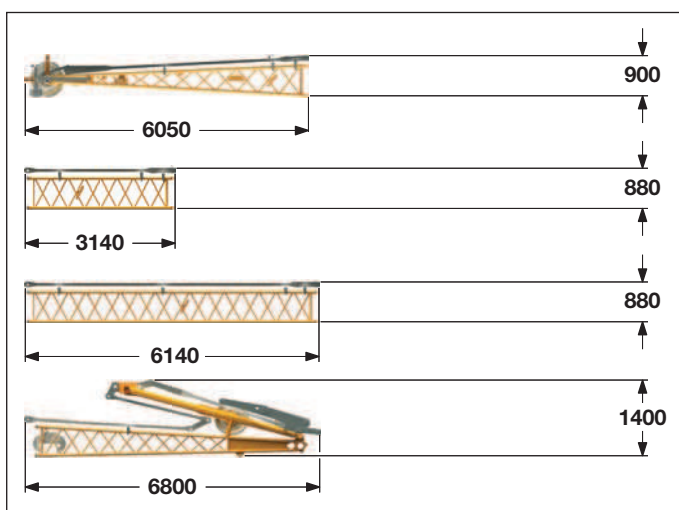

*) Including pendant straps

Fixed jib head (No. 0806.16)

Width	1140 mm
Weight*	475 kg

Fixed jib section (No. 0806.15)

3 m

Width	950 mm
Weight*	150 kg

Fixed jib section (No. 0806.15)

6 m

Width	950 mm
Weight*	255 kg

Fixed jib foot with A-frame (No. 0806.16)

Width	1500 mm
Weight*	1210 kg

Transport dimensions and weights

Counterweight

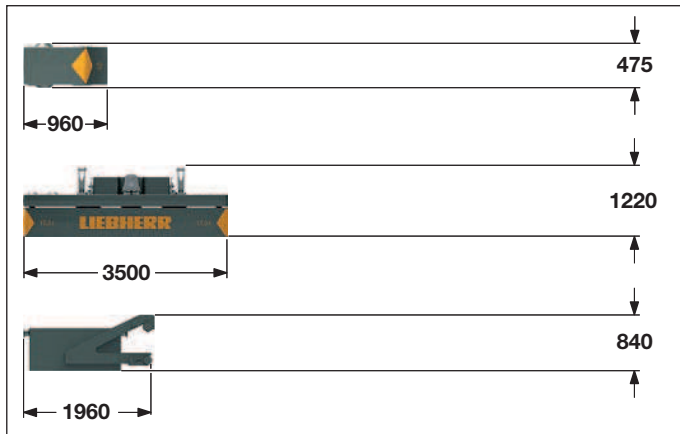

Counterweight 6x

option **10 x**

Width	850 mm
Weight	1500 kg

Counterweight

1 x

Width	1050 mm
Weight	17330 kg

Carbody counterweight

option **2 x**

Width	1640 mm
Weight	7500 kg

Hooks

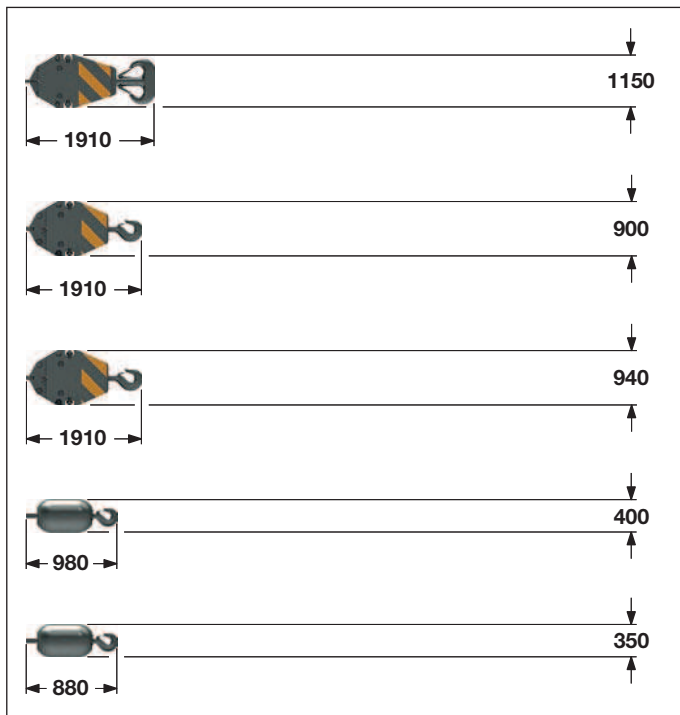

100 t hook block - 2 sheaves

Width	320 mm
Weight	1200 kg

50 t hook block - 1 sheave

Width	400 mm
Weight	900 kg

40 t hook block - 1 sheave

Width	250 mm
Weight	515 kg

25 t single hook

Width	400 mm
Weight	400 kg

20 t single hook

Width	350 mm
Weight	350 kg

Technical description



Engine

Power rating according to ISO 9249, 390 kW (523 hp) at 1700 rpm

Engine type _____ Liebherr D 856 A7 SCR

Fuel tank _____ 790 l capacity with continuous level
_____ indicator and reserve warning

Engine complies with NRMM exhaust certification EPA / CARB Tier 4i or 97/68 EC Stage III B.

ECO-Silent-Mode:

For work not requiring high engine power, the diesel engine can be operated in the ECO-Silent-Mode (e.g. for inserting reinforcement cages, for dragline or lift crane operation).

Due to the ECO-Silent-Mode which can be preselected by the operator the engine runs with optimum fuel efficiency. This lowers consumption and reduces noise emission.



Hydraulic system

The main pumps are operated by a distributor gearbox. Axial piston displacement pumps work in closed and open circuits supplying oil only when needed (flow control on demand). To minimize peak pressure an automatically working pressure cut-off is integrated. This spares pumps and saves energy. The hydraulic oil is cleaned through electronically controlled pressure and return filters. Possible contamination is signaled in the cabin.

Ready made hydraulic retrofit kits are available to customize requirements e.g. powering casing oscillators, VM-vibrators, hydraulic grabs, fixed leaders etc.

Working pressure _____ max. 400 bar

Oil tank capacity _____ 910 l



Boom winch

Line pull _____ max. 105 kN

Rope diameter _____ 20 mm

Boom up _____ 44 sec. from 15° to 86°



Swing

Consists of rollerbearing with external teeth for lower tooth flank pressure, fixed axial piston hydraulic motor, spring loaded and hydraulically released multi-disc holding brake, planetary gearbox and pinion.

Swing speed from 0–4.6 rpm continuously variable, selector for 3 speed ranges to increase swing precision.

Option:

Second swing drive



Noise emission

Noise emissions correspond with 2000/14/EC directive on noise emission by equipment used outdoors.



Main winches

Winch options:

Line pull (nom. load) _____ 160 kN _____ 200 kN _____ 250 kN

Rope diameter _____ 26 mm _____ 30 mm _____ 34 mm

Drum diameter _____ 580 mm _____ 630 mm _____ 750 mm

Rope speed _____ 0–99 m/min - 0–101 m/min - 0–87 m/min

Rope capacity 1st layer - 51.9 m _____ 40.6 m _____ 38.8 m

The winches are outstanding in their compact design and easy assembly. Clutch and braking functions on the free-fall system are provided by a compact designed, low wear and maintenance-free multi-disc brake.

The drag and hoist winches use pressure controlled, variable flow hydraulic motors. This system features sensors that automatically adjust oil flow to provide max. winch speed depending on load.

Option:

Auxiliary winch _____ 70 kN in boom foot

Tagline winch _____ 30 kN with free fall



Crawlers

The track width of the undercarriage is changed hydraulically. Propulsion through axial piston motor, hydraulically released spring loaded multi-disc brake, maintenance-free crawler tracks, hydraulic chain tensioning device.

3-web grousers _____ 800 mm

Drive speed _____ 0 – 1.28 km/h

Option:

- 2-speed hydraulic motor for higher travel speed
- Self-assembly system, jack-up system



Control

The core of the Liebherr hydraulic crawler cranes is the Litronic control system.

Developed and manufactured by Liebherr, this comprehensive system encompasses all control and monitoring functions and is designed to withstand extreme temperature changes and the rough heavy duty tasks common in the construction industry. Complete machine operating data, warnings and failure indications are clearly displayed in the required language on the high resolution monitor in the operator's cab.

Documentation of operating data (PDE) enables optimum diagnosis as well as early detection and prevention of more serious defects.

An electro-hydraulic proportional control allows several movements to be performed simultaneously. This ensures that all categories of loads can be positioned with utmost precision.

Options:

- PDE: Process data recording
- GSM/GPRS telematics module
- Special demolition control system

Equipment (26.3 t counterweight)

Casing oscillator and slurry wall grab

Boom 1311.22



Boom 1311.22



Casing oscillator*

Winch options	2 x 200 kN	—	2 x 250 kN
Line speed 1st layer (m/min)	0-101	—	0-87
Drilling diameter	2000 mm	—	2000 mm

Slurry wall grab*

Winch options	2 x 200 kN	—	2 x 250 kN
Line speed 1st layer (m/min)	0-101	—	0-87
Max. chisel weight	12 t	—	16 t

*) Load chart for duty cycle operation see page 8

Equipment (26.3 t counterweight)

Dynamic soil compaction



Capacities in metric tonnes for boom lengths (21 m - 33 m)					
Radius	Boom length (m)				
	21	24	27	30	33
(m)	t	t	t	t	t
8	25	25	20	20	19
9	20	19	19	18	17

Capacities in metric tonnes for boom lengths (20 m - 32 m)					
Radius	Boom length (m)				
	20	23	26	29	32
(m)	t	t	t	t	t
8	25	25	20	20	19
9	20	19	19	18	17

Max. capacities in metric tonnes do not exceed 75% of tipping load. All loads given are max. values and must not be exceeded. They are only permitted in two-rope automatic operation and are valid for work on a surface with max. inclination of 1%. Lifting heights must not exceed 25 m.

Load chart for duty cycle operation (main boom No. 1311.22)

26.3 t counterweight

Capacities in metric tonnes for boom lengths (11 m - 32 m)									Counterweight 26.3 t
Radius (m)	Boom length (m)								Radius (m)
	11 t	14 t	17 t	20 t	23 t	26 t	29 t	32 t	
4.2								28.2	4.2
5					37.9	34.6	28.2	23.5	5
6	37.9	37.9	37.9	37.6	37.9	34.6	28.2	23.5	6
7	37.7	37.9	36.5	36.0	34.6	34.4	28.2	23.5	7
8	34.4	33.5	33.0	32.1	30.6	28.9	26.2	23.5	8
9	28.9	28.5	27.6	27.1	26.1	25.1	22.8	21.0	9
10	24.5	24.0	23.3	22.6	22.1	21.3	20.4	18.7	10
12		17.9	17.6	17.3	16.9	16.3	16.0	15.3	12
14		15.0	14.8	14.4	14.1	13.7	13.3	12.9	14
16			12.7	12.4	12.1	11.8	11.4	11.2	16
18				10.8	10.6	10.3	10.0	9.7	18
20				9.6	9.3	9.1	8.8	8.6	20
22					8.3	8.1	7.8	7.5	22
24						7.1	7.0	6.7	24
26							6.2	5.9	26
28							5.4	5.3	28
30								4.7	30

TLT 11221530 M00000 Vorab3

Maximum capacity in duty cycle operation with standard ropes				
Line pull (1st layer)	kN	160	200	250
Rope diameter	mm	26	30	34
Minimum breaking load	kN	615	846	1046
Line pull - 1-rope duty cycle operation	t	16	20	25
Line pull - 2-rope duty cycle operation ¹⁾	t	24.2	30.3	37.9

- 1) Lifting a load exceeding the line pull of one winch is only allowed if it can be ensured that each individual winch is not overloaded. When working with a mechanical 2-rope grab the total load to be lifted is limited by the line pull of one winch. Rigging and ropes are part of the load.
- 2) Max. capacities in metric tonnes do not exceed 75% of tipping load. Crane standing on firm, horizontal ground.

Capacities in duty cycle operation are for reference only and are not programmed in the LMI system. All loads and counterweight configurations are max. values and must not be exceeded. Weight of additional equipment on boom (e.g. walkways, hose drums etc.) must be deducted to get the net capacity.

Dragline equipment (main boom No. 1311.22)

26.3 t counterweight

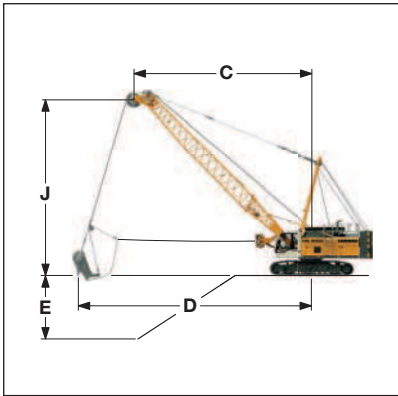

Capacities in metric tonnes for boom lengths (14 m - 29 m)																	counterweight 26.3 t		
alpha	Boom length (m)																		
	14			17			20			23			26			29			
	C	J	t	C	J	t	C	J	t	C	J	t	C	J	t	C	J	t	
	(m)	(m)	t	(m)	(m)	t	(m)	(m)	t	(m)	(m)	t	(m)	(m)	t	(m)	(m)	t	
45	11.9	11.4	18.0	14.1	13.5	14.7	16.2	15.6	12.3	18.3	17.8	10.4	20.4	19.9	8.9	22.5	22.0	7.6	
40	12.7	10.4	16.8	15.0	12.4	13.6	17.3	14.3	11.3	19.6	16.2	9.6	21.9	18.2	8.2	24.2	20.1	6.9	
35	13.4	9.4	15.7	15.9	11.2	12.8	18.3	12.9	10.6	20.8	14.6	8.9	23.2	16.3	7.5	25.7	18.0	6.3	
30	14.0	8.4	15.0	16.6	9.9	12.1	19.2	11.4	10.0	21.8	12.9	8.4	24.4	14.4	6.9	27.0	15.9	5.8	
25	14.5	7.3	14.4	17.3	8.5	11.6	20.0	9.8	9.6	22.7	11.1	7.9	25.4	12.3	6.5	28.1	13.6	5.4	

TLT 11221530 M00000 Vorab3

Max. capacities in metric tonnes do not exceed 75% of tipping load.
 Capacities in duty cycle operation are for reference only and are not programmed in the LMI system.
 The size of the bucket has to be determined according to local conditions.

Digging diagram

- C = Radius / dumping radius
- D = Max. digging radius = approx.
C + 1/3 to 1/2 J
- E = Digging depth = approx.
40 - 50% of C
- J = Height to centre rope pulley boom head

Clamshell equipment (main boom No. 1311.22)

26.3 t counterweight

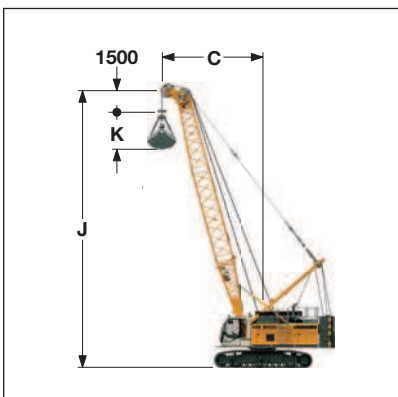

Capacities in metric tonnes for boom lengths (14 m - 29 m)																	counterweight 26.3 t		
alpha	Boom length (m)																		
	14			17			20			23			26			29			
	C	J	t	C	J	t	C	J	t	C	J	t	C	J	t	C	J	t	
	(m)	(m)	t	(m)	(m)	t	(m)	(m)	t	(m)	(m)	t	(m)	(m)	t	(m)	(m)	t	
65	8.1	14.4	32.0	9.3	17.1	26.0	10.6	19.8	20.6	11.9	22.5	17.1	13.2	25.2	14.8	14.4	28.0	12.9	
60	9.1	13.7	26.8	10.6	16.3	21.2	12.1	18.9	17.1	13.6	21.5	14.6	15.1	24.1	12.6	16.6	26.7	11.0	
55	10.1	13.0	23.2	11.9	15.5	17.9	13.6	18.0	15.0	15.3	20.4	12.8	17.0	22.9	11.0	18.7	25.3	9.6	
50	11.1	12.3	20.3	13.0	14.6	16.1	14.9	16.9	13.4	16.9	19.1	11.5	18.8	21.4	9.8	20.7	23.7	8.5	
45	11.9	11.4	18.0	14.1	13.5	14.7	16.2	15.6	12.3	18.3	17.8	10.4	20.4	19.9	8.8	22.5	22.0	7.6	
40	12.7	10.4	16.8	15.0	12.4	13.6	17.3	14.3	11.2	19.6	16.2	9.4	21.9	18.2	8.0	24.2	20.1	6.8	
35	13.4	9.4	15.7	15.9	11.2	12.6	18.3	12.9	10.4	20.8	14.6	8.7	23.2	16.3	7.3	25.7	18.0	6.2	
30	14.0	8.4	14.9	16.6	9.9	11.8	19.2	11.4	9.7	21.8	12.9	8.1	24.4	14.4	6.8	27.0	15.9	5.8	
25	14.5	7.3	14.1	17.3	8.5	11.2	20.0	9.8	9.2	22.7	11.1	7.6	25.4	12.3	6.4	28.1	13.6	5.4	

TLT 11221519 M00000 Vorab3

Max. capacities in metric tonnes do not exceed 66.7% of tipping load.
 Capacities in duty cycle operation are for reference only and are not programmed in the LMI system.

Working diagram

- C = Radius / dumping radius
- J = Height of boom head sheave centre above ground level
- K = Length of clamshell (according to manufacturer's specification)

Working range - main boom (No. 1311.22)

26.3 t counterweight and 15 t carbody counterweight

86° - 15°

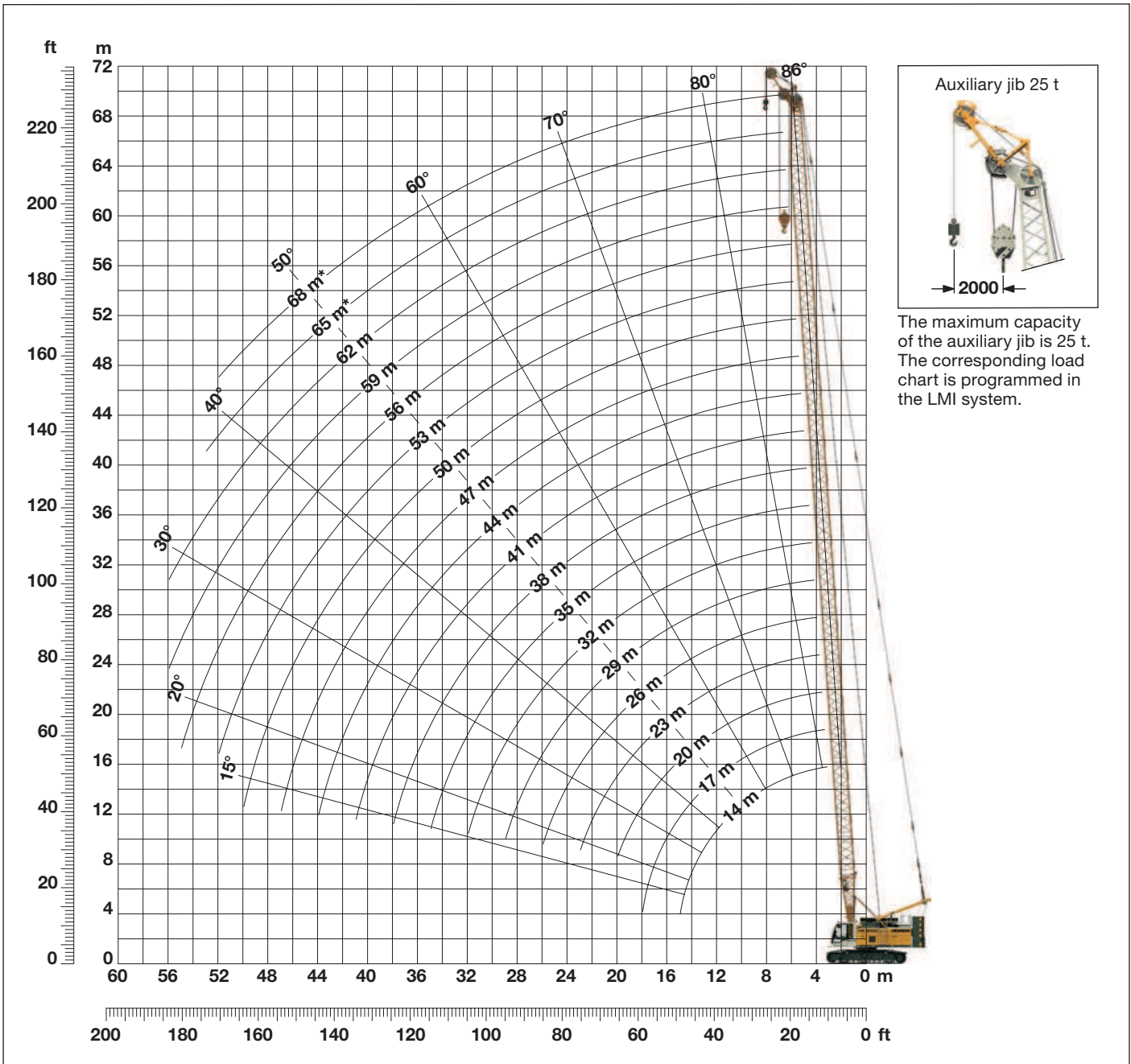

Main boom configuration (Table 1 - No. 1311.xx)

Configuration for boom lengths (11 m - 68 m)

Component	Length	Amount of boom extensions																			
		1	1	1	1	1	1	1	1	1	1	1	1	1	1	1	1	1	1	1	
Boom foot	5.5 m	1	1	1	1	1	1	1	1	1	1	1	1	1	1	1	1	1	1	1	
Boom section	3.0 m		1		1		1		1		1		1		1		1		1		
Boom section	6.0 m			1	1	2	2	3	3	2	2	3	3	2	2	3	3	2	2	3	3
Boom section	12.0 m									1	1	1	1	2	2	2	2	3	3	3	3
Boom head	5.5 m	1	1	1	1	1	1	1	1	1	1	1	1	1	1	1	1	1	1	1	1
Boom length (m)		11	14	17	20	23	26	29	32	35	38	41	44	47	50	53	56	59	62	65*	68*

*) Additional counterweight allows self-erection of boom up to 68 m.

Load chart for lift crane operation (main boom No. 1311.22)

26.3 t counterweight

Capacities in metric tonnes for boom lengths (11 m - 62 m) - with 250 kN winches and 26.3 t counterweight

Radius (m)	Boom length (m)																	Radius (m)
	11	14	17	20	23	26	29	32	35	38	41	44	47	50	53	56	59	
3.8							67.8											3.8
4						69.1	65.0	60.8										4
5				61.2	58.0	55.0	52.3	49.7	47.6	45.5	40.1	35.3						5
6	57.9	55.0	52.3	49.9	47.6	45.5	43.5	41.7	40.1	38.5	37.0	34.6	31.1	27.6	24.1	21.3	18.2	6
7	47.4	45.7	43.8	41.9	40.3	38.7	37.2	35.7	34.6	33.3	32.1	30.9	30.0	26.9	23.7	21.2	18.2	7
8	38.8	39.0	37.5	36.1	34.8	33.5	32.3	31.2	30.3	29.2	28.2	27.3	26.5	25.6	23.2	20.5	17.5	8
9	32.7	32.9	32.8	31.6	30.6	29.5	28.5	27.6	26.9	26.0	25.1	24.3	23.7	22.9	22.2	20.0	17.0	9
10	28.2	28.4	28.4	28.1	27.2	26.3	25.5	24.6	24.1	23.3	22.6	21.9	21.3	20.7	20.0	19.2	16.4	10
12	20.6	22.0	22.1	22.1	22.0	21.5	20.8	20.3	19.9	19.3	18.7	18.2	17.8	17.3	16.7	16.1	15.3	12
14		17.9	18.0	18.0	17.9	17.9	17.6	17.0	16.8	16.3	15.8	15.3	15.0	14.6	14.1	13.7	13.3	14
18			12.6	12.7	12.7	12.6	12.5	12.4	12.5	12.1	11.8	11.4	11.2	10.8	10.5	10.1	9.9	18
20				10.9	10.9	10.8	10.7	10.6	10.7	10.6	10.3	10.0	9.8	9.5	9.2	8.8	8.6	20
22					9.5	9.4	9.3	9.2	9.3	9.2	9.0	8.8	8.6	8.3	8.0	7.7	7.6	22
26						7.2	7.2	7.1	7.2	7.0	6.9	6.8	6.8	6.5	6.3	6.0	5.9	26
28							6.4	6.3	6.4	6.2	6.1	6.0	6.0	5.8	5.6	5.3	5.2	28
30								5.6	5.7	5.5	5.4	5.3	5.3	5.2	5.0	4.7	4.6	30
32								4.9	5.0	4.9	4.8	4.7	4.7	4.5	4.4	4.2	4.1	32
34									4.5	4.4	4.3	4.1	4.1	4.0	3.9	3.7	3.6	34
36										3.9	3.8	3.7	3.7	3.5	3.4	3.3	3.2	36
38										3.5	3.4	3.2	3.3	3.1	3.0	2.8	2.8	38
40											3.0	2.9	2.9	2.7	2.6	2.5	2.4	40
42												2.5	2.5	2.4	2.3	2.1	2.1	42
44													2.2	2.2	2.1			44

TLT 10578151 M120160 Vorab 7

Above load chart is for reference only. For actual lift duty please refer to load chart in operator's cab or manual.

Load chart for lift crane operation (main boom No. 1311.22)

32.3 t counterweight and 15 t carbody counterweight

Capacities in metric tonnes for boom lengths (11 m - 68 m) - with 250 kN winches - 32.3 t counterweight and 15 t carbody counterweight

Radius (m)	Boom length (m)																				Radius (m)
	11	14	17	20	23	26	29	32	35	38	41	44	47	50	53	56	59	62	65	68	
2.8		100.0*																			2.8
3		90.0	90.0																		3
4	90.0	90.0	90.0	90.0	90.0	85.6	76.1	64.1													4
5	88.7	84.3	80.3	75.9	71.9	68.2	64.9	61.6	52.6	46.5	40.1	35.3									5
6	71.9	68.3	65.0	62.0	59.2	56.6	54.2	51.9	50.0	44.3	38.9	34.6	31.1	27.6	24.1	21.3	18.2				6
7	58.8	56.8	54.5	52.2	50.2	48.2	46.4	44.7	43.2	41.3	37.4	33.0	30.0	26.9	23.7	21.2	18.2	16.1	14.3	12.7	7
10	35.3	35.5	35.5	35.2	34.1	33.0	32.0	31.1	30.3	29.4	28.6	27.7	26.7	24.3	21.7	19.2	16.4	14.7	13.3	12.0	10
12	20.6	27.7	27.8	27.7	27.7	27.1	26.3	25.6	25.1	24.4	23.7	23.1	22.6	22.0	20.4	18.0	15.3	13.6	12.3	11.3	12
14		22.5	22.6	22.6	22.5	22.4	22.2	21.6	21.3	20.7	20.2	19.6	19.3	18.7	18.1	16.6	14.5	12.7	11.5	10.7	14
18			16.1	16.2	16.2	16.1	16.0	15.9	16.0	15.7	15.3	14.9	14.6	14.2	13.8	13.4	12.7	11.6	10.5	9.8	18
20				14.0	14.0	13.9	13.9	13.7	13.8	13.7	13.5	13.1	12.9	12.6	12.2	11.9	11.6	11.2	10.2	9.4	20
22					12.3	12.2	12.1	12.0	12.1	12.0	11.9	11.7	11.5	11.2	10.9	10.5	10.3	9.9	9.6	9.1	22
26						9.6	9.5	9.4	9.5	9.4	9.3	9.1	9.1	9.0	8.7	8.4	8.3	7.9	7.6	7.3	26
28							8.5	8.4	8.5	8.4	8.3	8.1	8.1	8.0	7.8	7.6	7.4	7.1	6.8	6.6	28
32								6.8	6.9	6.8	6.7	6.5	6.5	6.4	6.3	6.1	6.0	5.8	5.5	5.3	32
34									6.2	6.1	6.0	5.9	5.9	5.8	5.6	5.5	5.5	5.2	5.0	4.7	34
38										5.0	4.9	4.8	4.8	4.7	4.5	4.4	4.4	4.2	4.0	3.8	38
40											4.4	4.3	4.3	4.2	4.1	3.9	3.9	3.8	3.6	3.4	40
44												3.5	3.6	3.4	3.3	3.2	3.1	3.0	2.9	2.6	44
46													3.2	3.1	3.0	2.8	2.8	2.6	2.5	2.3	46
48														2.8	2.6	2.5	2.5	2.3	2.2	2.0	48
50														2.5	2.3	2.2	2.2	2.0			50

TLT 10578151 M120160 Vorab 7

Above load chart is for reference only. For actual lift duty please refer to load chart in operator's cab or manual.

*) With heavy duty boom head

Working range - fixed jib (No. 0806.xx)

15° and 30°

Main boom 86° - 30°

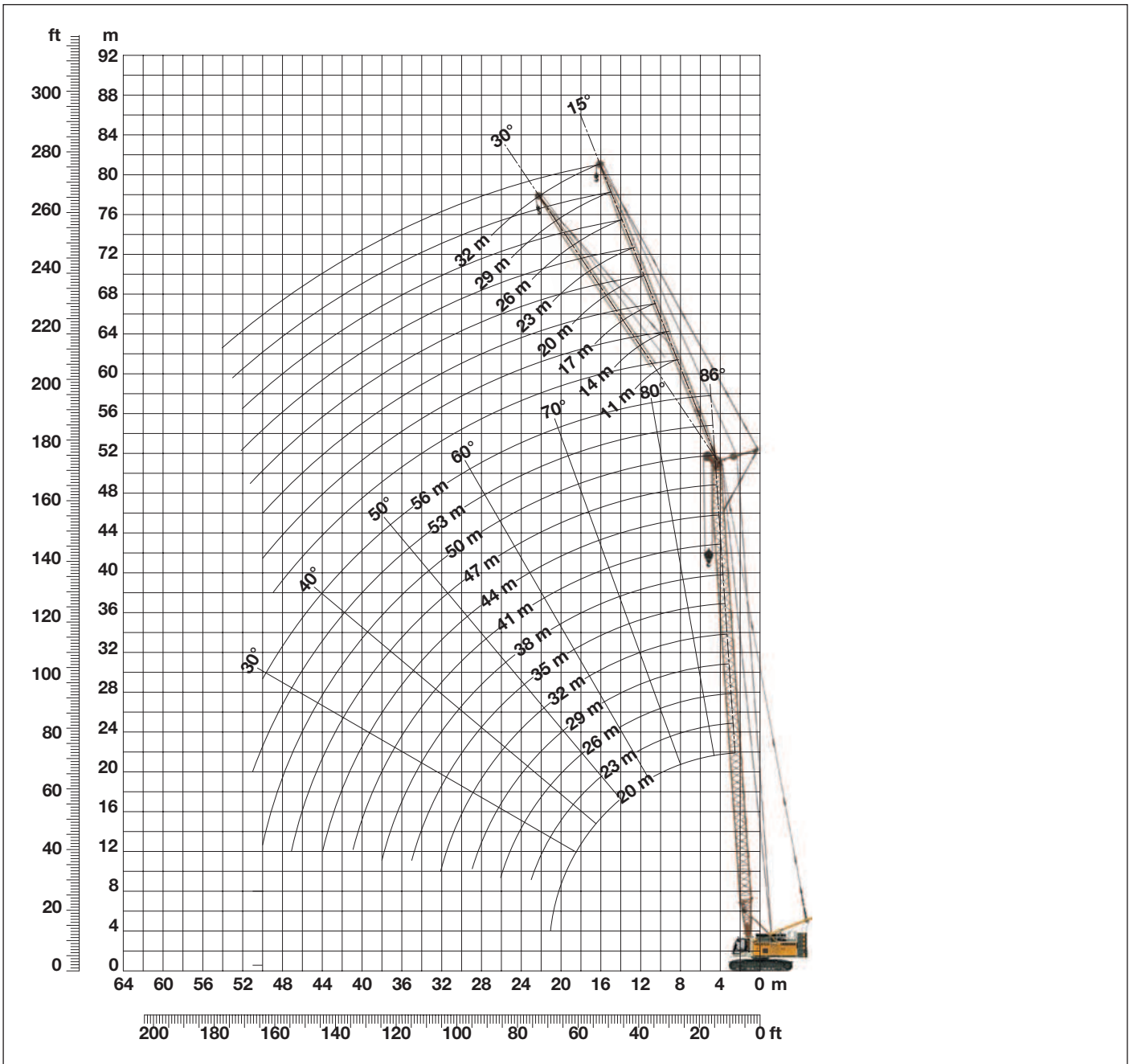

Boom configuration for boom lengths (11 m - 56 m) — see table 1, page 10

Fixed jib configuration for fixed jib lengths (11 m - 32 m)

	Length	Amount of fixed jib extensions								
		1	1	1	1	1	2	2	3	3
Fixed jib foot	5.5 m	1	1	1	1	1	1	1	1	1
Fixed jib section	3.0 m		1			1		1		1
Fixed jib section	6.0 m			1		1	2	2	3	3
Fixed jib head	5.5 m	1	1	1	1	1	1	1	1	1
Fixed jib length (m)		11	14	17	20	23	26	29	32	

Load chart - fixed jib (No. 0806.xx)

Offset 15°

Main boom 11 m

Radius	Fixed jib length (m)			
	11	20	26	32
(m)	t	t	t	t
4.7	29.4			
9	20.9	13.5		
12	17.5	11.7	7.5	
14	16.1	10.9	6.8	4.9
15	15.8	10.6	6.6	4.7
16	15.5	10.4	6.4	4.6
18	14.8	9.6	6.0	4.4
19	14.3	9.3	5.8	4.4
20	13.9	9.0	5.7	4.3
28		7.0	4.5	3.8
34			4.1	3.4
40				3.1

Main boom 20 m

Radius	Fixed jib length (m)			
	11	20	26	32
(m)	t	t	t	t
5.4	25.3			
10	18.7	12.4		
12	16.6	11.1	7.4	
15	15.1	9.8	6.7	4.7
18	14.3	8.4	6.3	4.4
20	13.0	7.6	5.9	4.3
24	11.0	6.2	5.3	4.1
26	9.8	5.8	4.8	4.0
28	8.8	5.4	4.4	3.8
36		4.5	3.5	2.9
42			3.1	2.5
48				2.2

Main boom 26 m

Radius	Fixed jib length (m)			
	11	20	26	32
(m)	t	t	t	t
5.8	23.1			
10	17.8	11.8		
13	15.4	10.2	7.0	
15	14.2	9.2	6.6	4.6
18	13.0	8.1	6.2	4.4
20	12.4	7.5	5.9	4.3
24	10.7	6.3	5.1	4.1
28	8.5	5.5	4.4	3.8
32	6.9	4.9	3.8	3.3
42		4.0	3.0	2.4
48			2.7	2.1
50				2.1

Main boom 32 m

Radius	Fixed jib length (m)			
	11	20	26	32
(m)	t	t	t	t
6.2	20.9			
11	16.1	10.6		
13	14.9	10.0	6.9	
16	13.7	8.7	6.4	4.5
20	13.0	7.5	5.7	4.2
24	10.4	6.6	5.0	4.1
28	8.2	5.7	4.5	3.6
32	6.6	5.1	3.9	3.3
36	5.3	4.6	3.5	2.9
38	4.8	4.4	3.4	2.7
46		3.6	2.9	2.2
50			2.7	2.1

Main boom 38 m

Radius	Fixed jib length (m)			
	11	20	26	32
(m)	t	t	t	t
6.6	19.3			
11	15.4	9.7		
14	13.6	8.4	5.9	
16	13.1	7.7	5.5	4.3
20	12.4	6.7	4.9	3.9
28	8.0	5.2	4.0	3.1
36	5.2	4.2	3.1	2.5
40	4.2	3.9	2.9	2.2
42	3.7	3.7	2.7	2.1
44	3.3	3.6	2.6	
50		2.8	2.4	
55			2.2	

Main boom 44 m

Radius	Fixed jib length (m)			
	11	20	26	32
(m)	t	t	t	t
7	17.5			
11	14.6	9.1		
14	12.8	8.1	5.8	
16	12.2	7.6	5.4	3.8
20	11.7	6.8	4.9	3.8
28	7.5	5.6	4.0	3.1
38	4.3	4.2	3.1	2.5
42	3.4	3.9	2.8	2.2
44	3.0	3.5	2.8	2.1
48	2.4	2.8	2.6	
50		2.5	2.5	
55			2.1	

Main boom 50 m

Radius	Fixed jib length (m)			
	11	20	26	32
(m)	t	t	t	t
7.4	15.1			
12	12.8	7.9		
14	11.9	7.2	5.3	
17	11.0	6.7	4.8	3.7
20	10.4	6.1	4.5	3.5
28	7.1	4.9	3.7	2.9
32	5.7	4.5	3.3	2.6
36	4.6	4.0	3.1	2.3
40	3.7	3.7	2.7	2.1
42	3.2	3.6	2.6	2.0
48	2.2	2.6	2.3	
50		2.3	2.2	

Main boom 53 m

Radius	Fixed jib length (m)			
	11	20	23	
(m)	t	t	t	
7.7	14.2			
12	12.2	7.7		
13	11.8	7.4	6.3	
16	10.8	6.7	5.7	
20	9.8	6.0	5.1	
28	6.8	5.0	4.3	
32	5.4	4.6	3.9	
36	4.3	4.1	3.6	
40	3.4	3.7	3.2	
44	2.7	3.0	2.9	
48	2.0	2.4	2.5	
50		2.1	2.2	

Main boom 56 m

Radius	Fixed jib length (m)			
	11	14		
(m)	t	t		
7.9	13.1			
10	12.2	10.5		
12	11.6	9.8		
16	10.4	9.0		
20	9.5	8.5		
24	8.3	7.7		
28	6.5	6.7		
32	5.2	5.3		
36	4.1	4.2		
40	3.2	3.3		
44	2.4	2.5		
46	2.1	2.2		

(TLT 10578151 M120160 Vorab 7)

Capacities in metric tonnes with fixed jib (No. 0806.xx), 32.3 t counterweight + 15 t carbody counterweight. Above load chart is for reference only. For actual lift duty please refer to load chart in operator's cab or manual.

Load chart - fixed jib (No. 0806.xx)

Offset 30°

Main boom 11 m

Radius	Fixed jib length (m)			
	11	20	26	32
(m)	t	t	t	t
7.4	20.4			
14	12.9	8.4		
18	11.0	7.1	5.4	
20	10.4	6.6	5.1	
22		6.2	4.9	3.7
24		5.9	4.6	3.5
28		5.3	4.1	3.2
30		5.2	4.0	3.1
32			3.8	2.9
36			3.6	2.7
38				2.6
42				2.5

Main boom 20 m

Radius	Fixed jib length (m)			
	11	20	26	32
(m)	t	t	t	t
8	18.4			
14	13.6	7.2		
18	11.1	6.3	4.9	
22	9.6	5.7	4.4	3.6
26	8.8	4.9	4.0	3.3
28	8.5	4.6	3.9	3.2
32		4.3	3.3	2.9
38		4.1	3.0	2.3
42			2.9	2.2
44			2.8	2.1
48				2.0
50				2.0

Main boom 26 m

Radius	Fixed jib length (m)			
	11	20	26	32
(m)	t	t	t	t
8.5	16.5			
15	12.5	6.3		
18	11.5	5.9		
19	10.9	5.7	4.3	
24	9.1	5.1	3.9	3.1
26	8.7	4.8	3.7	3.0
28	8.4	4.6	3.6	2.8
30	7.8	4.3	3.5	2.7
32	7.0	4.2	3.2	2.6
34	6.2	4.0	3.1	2.5
42		3.8	2.7	2.0
48			2.6	

Main boom 32 m

Radius	Fixed jib length (m)			
	11	20	26	32
(m)	t	t	t	t
8.9	14.8			
15	11.7	6.0		
19	11.1	5.5	4.1	
24	9.4	5.0	3.7	2.9
26	8.9	4.8	3.6	2.8
30	7.5	4.4	3.3	2.6
34	6.0	4.0	3.1	2.4
36	5.4	3.9	2.9	2.3
38	4.9	3.8	2.8	2.2
42		3.7	2.6	2.0
48		3.3	2.5	
50			2.5	

Main boom 38 m

Radius	Fixed jib length (m)			
	11	20	26	32
(m)	t	t	t	t
9.3	13.3			
16	10.7	5.0		
20	9.7	4.6	3.4	
24	8.8	4.3	3.1	2.4
26	8.3	4.2	3.0	2.3
32	6.6	3.7	2.7	2.0
34	5.9	3.6	2.7	
38	4.8	3.3	2.4	
42	3.8	3.2	2.2	
44	3.4	3.1	2.2	
50		2.9	2.1	
55			2.0	

Main boom 44 m

Radius	Fixed jib length (m)			
	11	20	26	32
(m)	t	t	t	t
9.7	12.0			
16	10.1	4.8		
20	9.6	4.5	3.3	
24	9.2	4.3	3.0	2.3
26	8.7	4.1	2.9	2.2
30	7.1	3.9	2.8	2.1
34	5.7	3.7	2.6	
38	4.5	3.4	2.5	
42	3.6	3.2	2.3	
48	2.4	3.0	2.1	
50		2.7	2.1	
55			2.0	

Main boom 50 m

Radius	Fixed jib length (m)			
	11	20	26	32
(m)	t	t	t	t
10.1	10.8			
16	9.0	4.5		
20	8.5	4.2	3.0	
22	8.1	4.0	2.9	
24	7.8	3.9	2.8	2.1
26	7.6	3.8	2.7	2.0
30	6.7	3.5	2.6	
34	5.4	3.4	2.4	
38	4.3	3.1	2.3	
42	3.4	2.9	2.1	
48	2.3	2.7		
50		2.5		

Main boom 53 m

Radius	Fixed jib length (m)			
	11	20	23	26
(m)	t	t	t	t
10.3	10.2			
17	8.6	4.4		
19	8.4	4.2	3.6	
22	8.0	4.0	3.4	2.9
26	7.6	3.8	3.2	2.7
30	6.4	3.6	3.0	2.5
34	5.1	3.4	2.8	2.4
38	4.1	3.1	2.7	2.3
42	3.2	2.9	2.5	2.1
44	2.8	2.8	2.4	2.0
48	2.2	2.6	2.3	
50		2.3	2.2	

Main boom 56 m

Radius	Fixed jib length (m)			
	11	14		
(m)	t	t		
10.5	9.6			
13	9.0	7.3		
14	8.7	7.1		
16	8.4	6.8		
18	8.3	6.5		
20	8.1	6.3		
24	7.7	6.0		
32	5.5	5.3		
40	3.4	3.6		
44	2.6	2.8		
46	2.3	2.4		
48		2.1		

(TLT 10578151 M120160 Vorab 7)

Capacities in metric tonnes with fixed jib (No. 0806.xx), 32.3 t counterweight + 15 t carbody counterweight. Above load chart is for reference only. For actual lift duty please refer to load chart in operator's cab or manual.

Self-assembly system

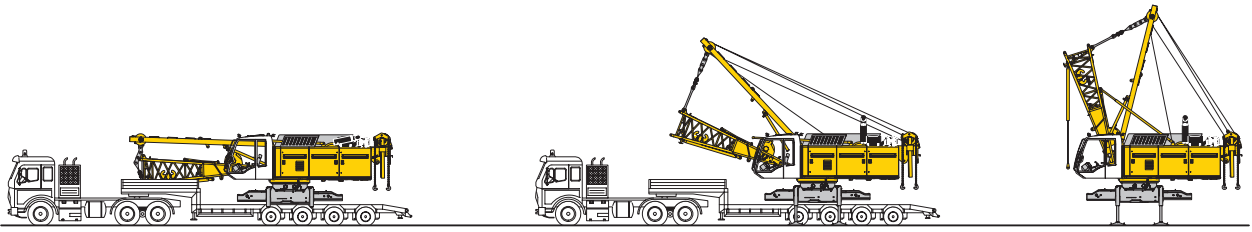

Unloading of basic machine (option)

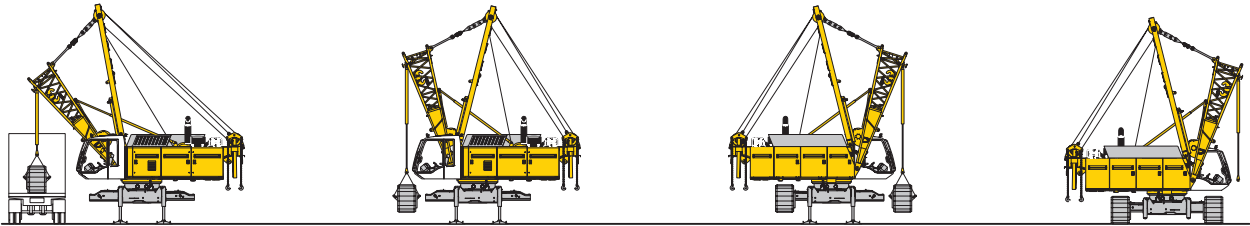

Unloading and assembly of crawlers

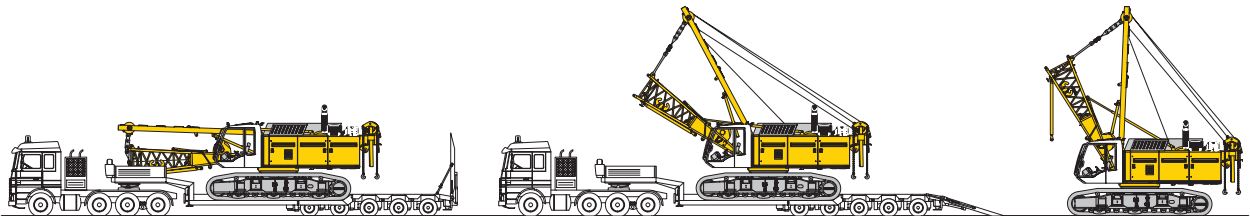

Unloading of basic machine (standard)

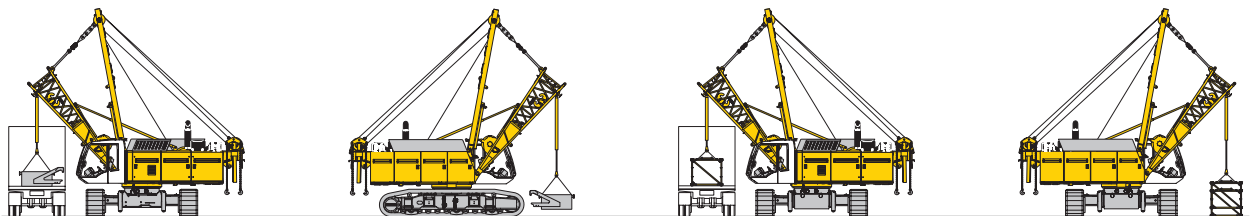

Unloading and assembly of carbody counterweight

Unloading and assembly of boom

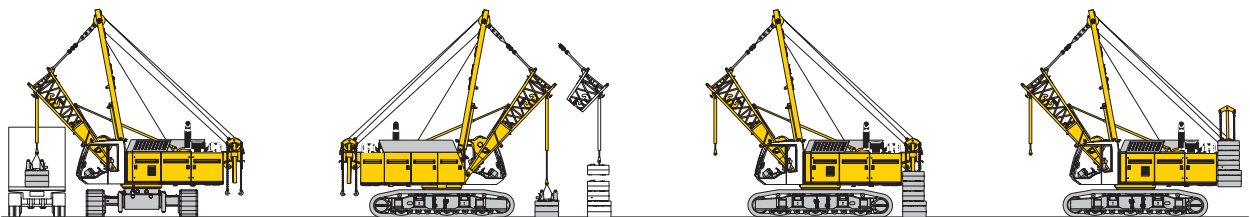

Unloading and assembly of counterweight

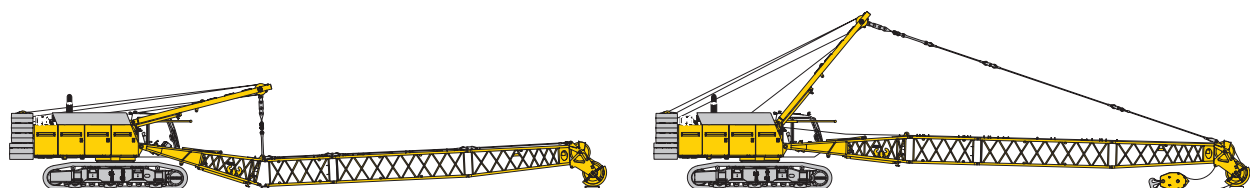

Assembly of boom and reeving of hoist ropes

Liebherr-Werk Nenzing GmbH

Dr. Hans Liebherr Str. 1, 6710 Nenzing/Austria
Tel.: +43 50809 41-473, Fax: +43 50809 41-499
crawler.crane@liebherr.com, www.liebherr.com
facebook.com/LiebherrConstruction