

# Mobile Crane

# LTM 1100-5.2

Max. capacity: 100 t

Max. hoisting height: 84 m

Max. radius: 66 m



# LIEBHERR

*Courtesy of Crane.Market*

# Mobile crane LTM 1100-5.2

## Flexibly and economically usable



A long telescopic boom, high capacities, an extraordinary mobility as well as a comprehensive comfort and safety configuration distinguish the mobile crane LTM 1100-5.2 from Liebherr. The 100-ton crane offers state of the art technology for more convenience for the practical operation.

- 52 m long telescopic boom and 14 m telescopic boom extension (2 x 7 m)
- Capacity 11.5 t at the 52 m long telescopic boom
- 19 m long double swing-away jib, optional hydraulically adjustable
- 12-speed ZF-AS-TRONIC-gearbox
- 60 t total weight incl. 11.5 t ballast and double swing away jib at 12 t axle load
- Chassis width 2.75 m with tyres 445/95 R 25 (16.00 R 25)
- Active, speed depending rear axle steering, all axles steered



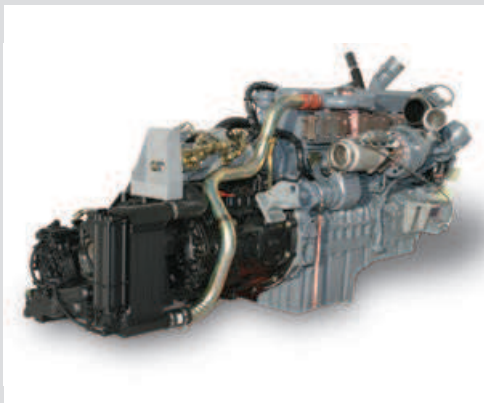

#### Drive train

- 6-cylinder Liebherr turbo-diesel engine, 370 kW/503 HP, max. torque 2355 Nm
- Automated ZF AS-TRONIC gearbox, 12 forward and 2 reverse speeds
- ZF-intarder directly at gearbox
- Axles 2, 4 and 5 driven, optional axle 1



# Most modern chassis and drive technology



## High mobility and efficiency

A powerful 6-cylinder Liebherr turbo-diesel engine with 370 kW/503 HP ensures swift driving performance. The automatic 12-speed power shift system ZF-ASTRONIC with intarder provides a high level of cost effectiveness and excellent comfort.

- Reduced fuel consumption due to the large number of gears and the high efficiency of the dry clutch
- Best manoeuvrability and minimum crawling speed due to 2-speed distribution gearbox
- Wear free braking with ZF-intarder
- Telma eddy current brake optional, wear free and comfortable

## Compact, mobile and weight-optimised

Thanks to its extremely compact design, the LTM 1100-5.2 can also operate on the smallest of construction sites.

- Chassis length only 11.60 m
- Smallest turning radius only 10.18 m
- Vehicle width only 2.75 m, even with tyres 445/95 R 25 (16.00 R 25)
- Tail swing radius only 3.84 m

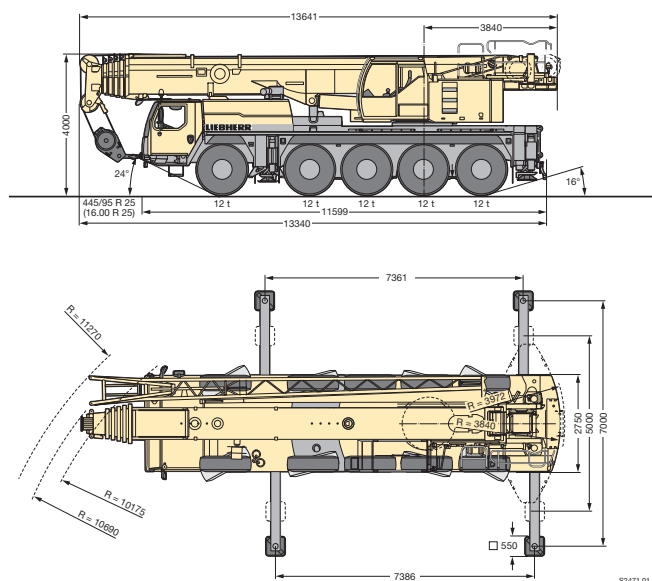

### Hydro-pneumatic suspension "Niveaumatik"

- Maintenance-free suspension cylinders
- Large dimensions to cope with high axle loads
- Suspension travel +150/-100 mm
- High lateral stability when cornering
- Choice of driving states using fixed programmes



### Telma eddy current brake (option)

- No wear, low maintenance system
- Increased safety due to fast activation in milliseconds
- Reduction of operation costs
- High comfort due to braking absolutely without jolts
- Environmentally friendly brake system, no emission and respirable dust



#### 5 steering programmes

- Selection of programme by simple push button
- Clear layout of control elements and displays
- Programmes changeable during driving
- Crab steering comfortably controlled by steering wheel



# Variable steering concept



## Centring cylinder at the rear axles

- Automatic straightening of rear axles in case of failure

## Active rear-axle steering

The rear axles are actively electro-hydraulically controlled in accordance with the speed and steering angle of the front axle. Five different steering programmes (P) can be selected by touch button.

- Remarkably reduced tyre wear
- Improved manoeuvrability
- Stable driving condition even at high speeds
- All 5 axles steerable

## High safety standards – entire know-how from Liebherr

- Centring cylinder for automatic straightening of rear axles in case of failure
- Two independent hydraulic circuits with wheel- and engine driven hydraulic pump
- Two independent control computers

### P1 Road steering

The axles 1 and 2 are steered mechanically by the steering wheel. The axles 3, 4 and 5 are steered actively speed depending and subject to the axle lock of the front axles. From 30 km/h the axles 3 and 4 are set to straight driving and locked. At speeds higher than 60 km/h also the axle 5 is set to straight drive and locked.

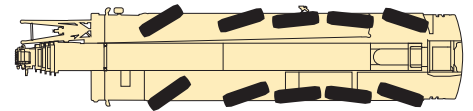

### P2 All-wheel steering

The axles 3, 4 and 5 are turned depending of the axle lock of the front axles by the steering wheel so far that smallest turning radii are achieved.

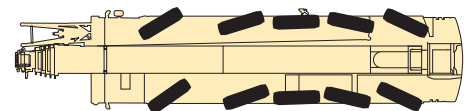

### P3 Crab steering

The axles 3, 4 and 5 are turned in the same direction as the wheel lock on axles 1 and 2 by the steering wheel.

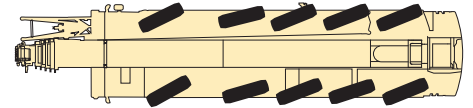

### P4 Reduced swing out

The axles 3, 4 and 5 are turned depending on the axle lock of the front axles, so that the swing out of the chassis rear gets minimized.

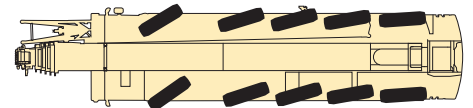

### P5 Independent rear-axle steering

The axles 1 and 2 are turned by using the steering wheel; the axles 3, 4 and 5 are steered by push button independently from the axle lock of the axles 1 and 2.

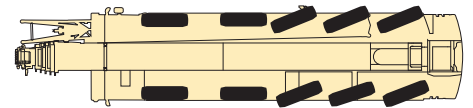



#### The driver's cab

- Corrosion-resistant
- Safety glass on all sides
- Tinted glass
- Electric windows
- Heated and electronically adjustable outside mirrors
- Air-sprung driver's seat with lumbar support



# Comfort and functionality



## Modern driver's cab and crane cab

Both the modern driver's cab and the rearwards tiltable crane cab offer a comfortable and functional working environment. The control elements and displays are ergonomically arranged. Thus a safe and fatigue free working is assured.

## Speedy and safe set-up

Setting of the outriggers, counterweight assembly and attachment of additional equipment have all been designed with speed, safety and comfort in mind. Specific ascents, handholds and rails are provided to ensure the safety of the operating staff.



### Supporting crane on outriggers – quick, comfortable and safe

- BTT blue tooth terminal, mobile control and display unit
- Electronic inclination display
- Fully automatic levelling by push button
- Engine start/stop and speed control
- Support area lighting with four integrated lights
- Support cylinder stroke: front 650 mm, rear 700 mm
- Outrigger beams 1-stage, fully hydraulic, low-maintenance extension system

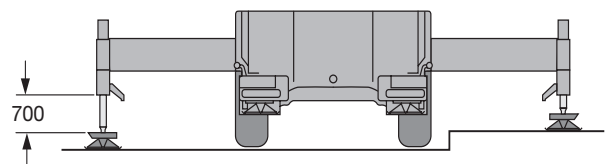

### The crane cab

- Large field of vision
- Safety glazing
- Tinted window panes
- Crane driver's seat with lumbar support, multiply adjustable
- Heat and noise insulated interior cladding
- Corrosion resistant
- Working floodlight
- Can be tilted 20° backwards



**The fully automatic telescoping system "TELEMATIK"**

- Increase of capacities at long booms and wider radii due to "light" telescoping system
- Single stage hydraulic cylinder with hydraulically activated drive pin
- Maintenance free telescoping system
- Telescoping fully automatic
- Simple operation, monitoring of the telescoping procedure at LICCON-monitor

**2.9 m long assembly jib**



# High lifting capacities and flexible boom system

## High-capacity, long telescopic boom and functional lattice extensions

The telescopic boom comprises of the base section and 5 telescopic sections, which can be comfortably and automatically extended and pinned to the requested lengths by the thousand fold proven single cylinder telescoping system TELEMATIK.

- 52 m long telescopic boom
- 10.8 m – 19 m long double swing away jib, attachable at 0°, 20° and 40°
- Hydraulic adjustment of the swing away jib under full load from 0° – 40° (option), interpolation of the load charts
- Hydraulic assembly assistance for attaching of the swing away jib with the BTT
- 2 sections 7 m each for extending the telescopic boom for operation with swing away jib

## High lifting capacities both with full and partial counterweight offer a wide operational range

- High lateral stability due to the oval boom profile
- Optimised load charts due to multitude of extension versions
- Load 11.5 t at 52 m long telescopic boom

## High capacities at unpinned telescopic lengths

- High telescopable loads due to interpolation
- Separate load charts for holding the loads at unpinned telescopic lengths
- Display at LICCON-monitor

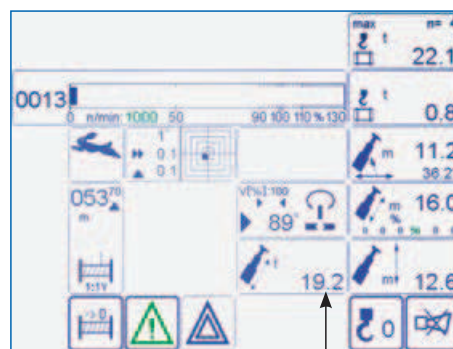

← Holding capacity

← Unpinned telescope length

← Telescopable load

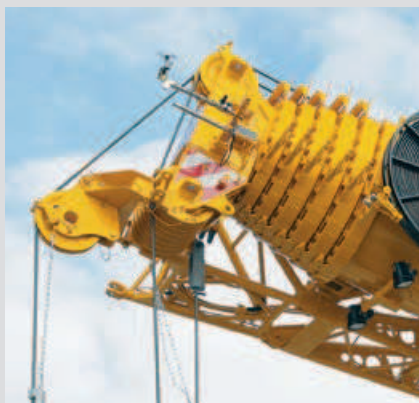
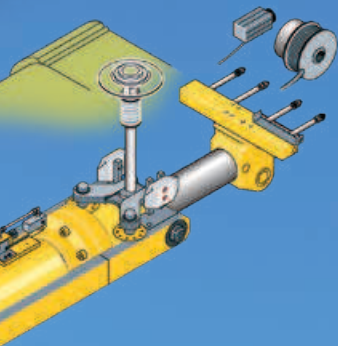
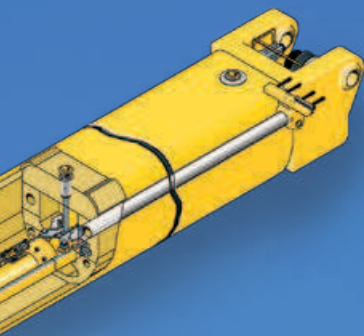
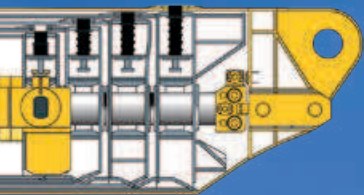

Boom nose, sidewise folding



Hydraulic assembly support for attaching the swing away jib by BTT

# Hydraulic swing away jib

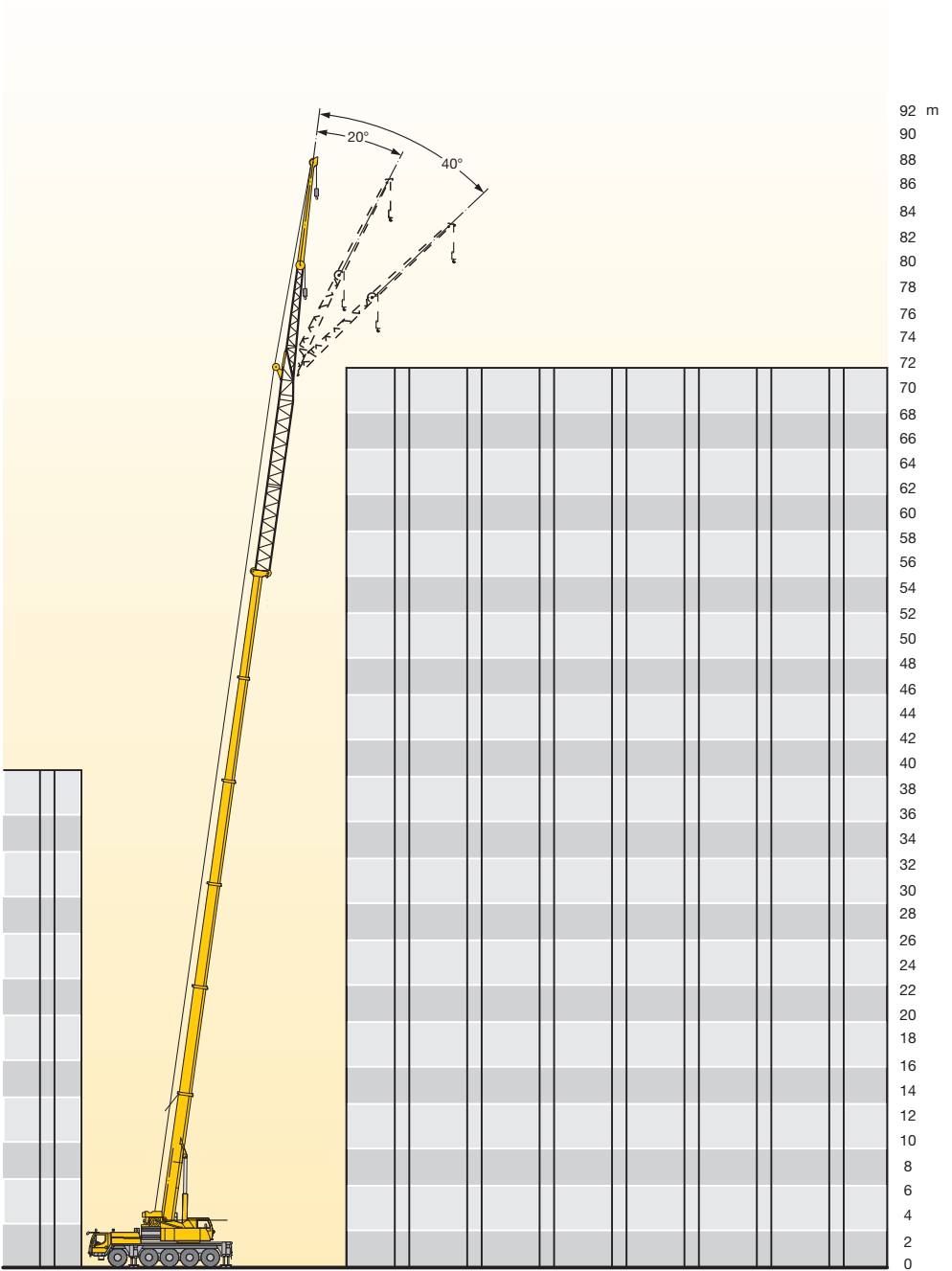

Hydraulically adjustable swing away jib (0° - 40°)



Hose drum for hydraulic cylinder



# Variable counterweight

## Counterweight assembly - a matter of minutes

- Multiple counterweight variations from 6.5 t to 35 t
- Rapid ballasting with keyhole technology from within the crane cab
- Compact counterweight dimensions, at 26 t ballast and double swing away jib only 2.75 m ballast width
- Tail swing only 3.84 m
- 60 t total weight incl. 11.5 t ballast and double swing-away jib at 12 t axle load

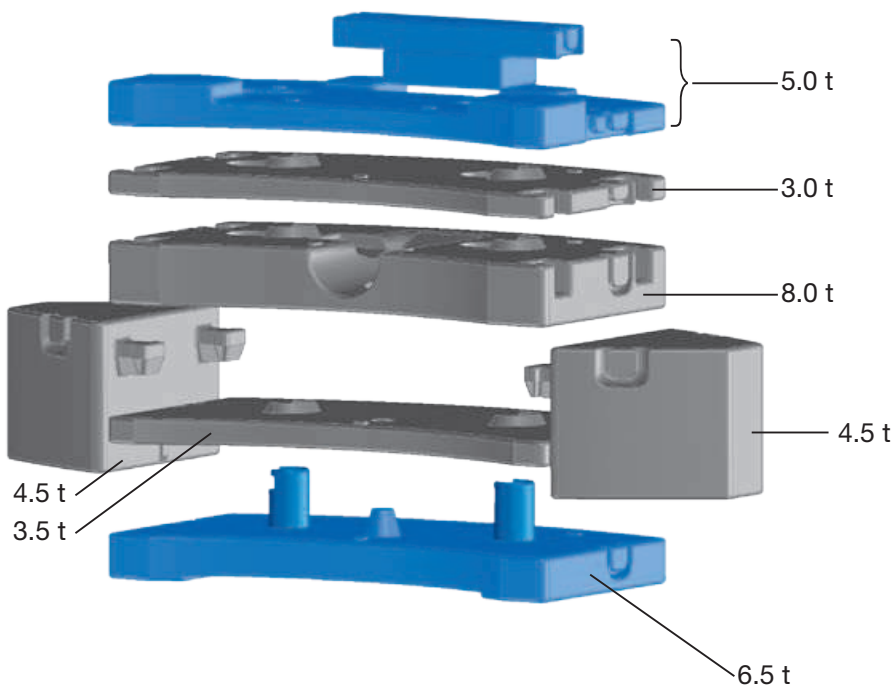

Basic counterweight	15 t
Additional counterweight I	11 t
Additional counterweight II	9 t
<b>Total</b>	<b>35 t</b>

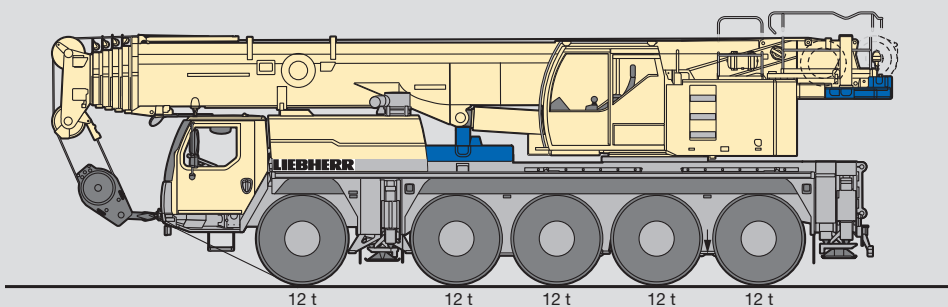



#### The hoist gear

- Liebherr hoist winch with internal planetary gear and spring loaded multiple disk brake
- Rope pull 88 kN at the outer layer
- Max. rope speed 130 m/min
- 2. hoist gear optional



# High-power crane drive

## With tried-and-tested components

The drive components for crane operation are designed for high performance and ensure sensitive and precise load handling. They are specially designed to suit the crane's usage and have been subjected to hard endurance tests.

- Crane engine: 4-cylinder Liebherr turbo diesel engine, 129 kW/175 HP, max. torque 815 Nm, optimised fuel consumption due to electronic engine management
- Diesel-hydraulic crane drive, open hydraulic circuits with electronic "LOAD SENSING" control, 4 working movements simultaneously possible
- Electric/electronic SPS crane control through the LICCON computer system
- Slewing system changeable from open to hydraulically locked as standard, thus the movement can be adjusted to the different operational conditions, e. g. sensitive control for assembly work or fast cycle work
- In-house manufactured Liebherr winches, 88 kN rope pull at the outer layer, due to high rope pull less rope reeving necessary

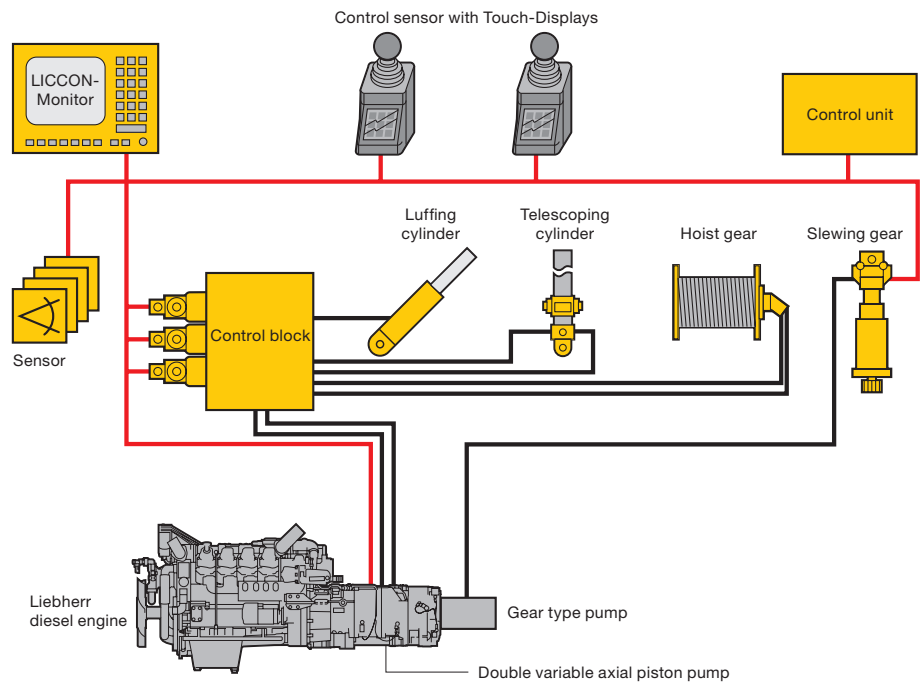

### The slewing gear

- Liebherr planetary gear, spring loaded multiple disk brake
- Changeable as standard: open or hydraulically locked
- Slewing speed from 0 – 2 rpm stepless adjustable



### The central greasing

- Central greasing device for slewing bearing, boom bearing, luffing cylinder and winch bearing as standard
- Even supply with grease
- Filling amount in transparent container visible at any time

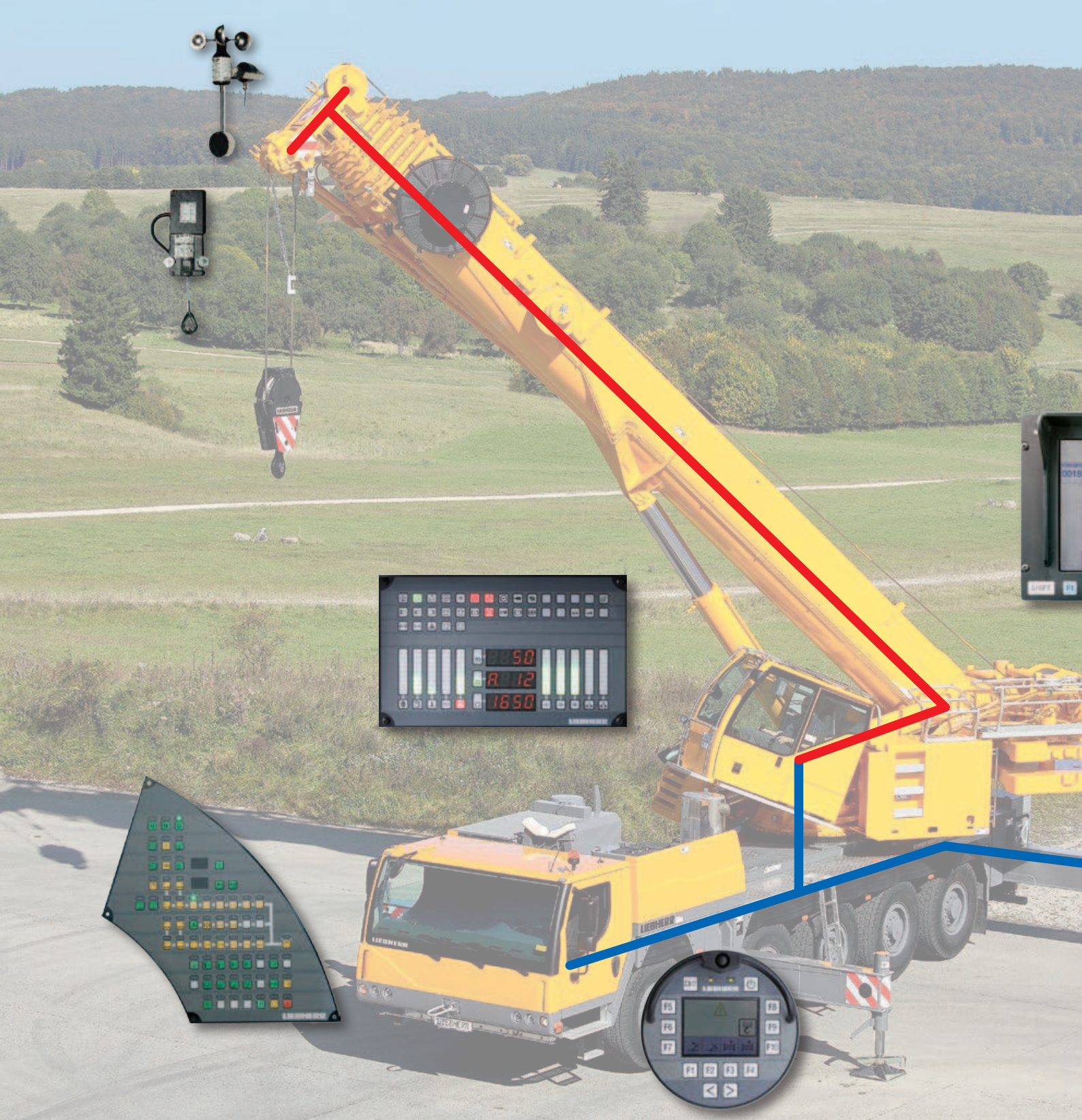

### The LICCON test system

- Rapid localisation of problems on-screen without any measuring instruments
- Display of error codes and descriptions
- Convenient interactive functions for monitoring all inputs and outputs
- Displays of functions and allocation of sensors and actuators

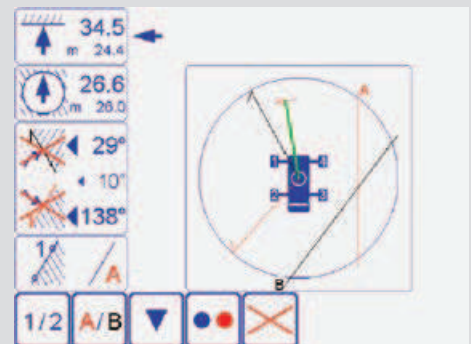



# Intelligent crane control



## For functional and safe crane operation: the LICCON computer system

The soft and hardware of the mobile crane control is developed by Liebherr in-house. The centre is the LICCON computer system (Liebherr Computed Control).

- Integrated LML load moment limiter
- Key components are in-house manufactured by Liebherr
- Guaranteed spare parts availability
- Worldwide proven under the most different climate conditions
- Operator friendly

The second control generation LICCON2 is the result of a continuous development by the Liebherr specialists and enables the adaption to the constantly increasing demands of the markets due to its modern and future oriented control.

## The data bus technology

Liebherr mobile cranes are completely interlaced by the data bus system. All important electric and electronic components are equipped with own micro processors and communicate with each other by only limited data cables. For the special demands of the mobile crane Liebherr has developed own data bus systems (LSB - Liebherr-System-Bus). The data bus technology improves the reliability, the comfort and the safety for road driving and crane operation:

- Higher reliability due to remarkable lesser electric cables and contacts
- Continuous self testing of the „intelligent sensors“
- Comprehensive diagnosis possibilities, fast fault finding

## The LICCON working range limiting system

- Makes the crane operator's job easier by automatically monitoring workspace restrictions such as bridges, roofs, etc.
- Simple programming
- Four different limitation functions:
  - Pulley-head height limitation
  - Radius limitation
  - Slewing angle limitation
  - Edge limitation

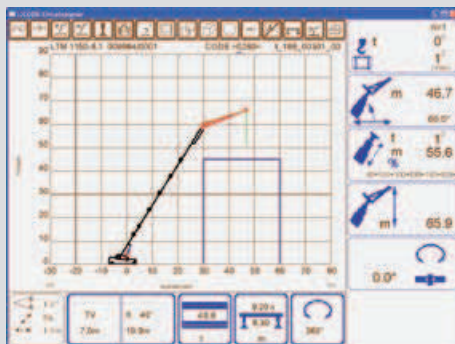

## The LICCON work planner

- Computer programme for planning, simulating and documenting crane operations on a PC
- Representation of all the crane's load charts
- Automatic search for suitable crane based on load, radius and lifting height parameters
- Simulation of crane operations with outline functions and supporting force display

# LICCON2 - safe and comfortable



## Attaching and detaching of the hook block

The BTT Bluetooth Terminal offers the crane driver the possibility to attach or detach the hook block at the front of the vehicle within sight, as the hoist winch and the luffing cylinder of the telescopic boom are remote controlled.



Wireless remote control

## Wireless remote control (option)

All crane motions can be controlled outside of the cab.

- Higher efficiency
- Free view and closeness to the load
- Prevention of communication errors between the crane driver and the job site personnel

## Supporting the crane

By use of the BTT the mobile crane will be setup comfortably and safely. Engine start/stop and speed regulation, electronic inclination display and automatic levelling are standard. Optionally the BTT can also display the outrigger forces.



## Colour monitor

The readability of the data on the monitor of the LICCON2 control system in the crane cab is enhanced by the colour display. Warnings and crane utilization are considerably better recognized.



## Touch display

Below the joysticks integrated in the arm rest touch displays are provided with which various working functions can be selected. Beside others these are the drive and steering programmes of the carrier, the supporting of the crane, the adjustment of the working floodlights as well as the heating and ventilation control.