

THE PERFECT SOLUTION FOR DEMANDING QUAY CONDITIONS

# DIESEL-ELECTRIC MODEL 2 MOBILE HARBOR CRANES



## MODEL 2 MOBILE HARBOR CRANES

# IDEAL FOR SMALLER TERMINALS

**Konecranes Gottwald Model 2 Mobile Harbor Cranes are extremely compact, diesel-electrically driven universal cranes for smaller maritime and river terminals. As representatives of the small crane family from Konecranes, they offer powerful lifting capacity curves with lifting capacities of up to 80 t, maximum radius of 40 m and lifting speeds of up to 100 m/min.**

Konecranes Gottwald Model 2 Mobile Harbor Cranes are designed for a particularly broad range of applications. In your universal or special-purpose terminal, they help you on vessels up to standard class to handle:

- containers,
- general cargo,
- bulk materials and
- project cargo.

### VARIANTS FOR DEDICATED APPLICATIONS

With Model 2 mobile harbor cranes, you profit, among other things, from high-performance two-rope variants for dedicated operation. A four-rope grab variant with a 32-t grab curve is available for professional handling of bulk materials for you.

Specially for narrow quays, the Model 2 is also available as a rubber-tired portal harbor crane. The rubber-tired portal can move in all directions and allows unimpeded truck or train traffic under the portal.

Model 2 mobile harbor cranes are an excellent solution for demanding quay conditions and possess all the features you expect in a handling machine for productive and durable operation. Model 2 cranes are:

- versatile,
- easy to maintain,
- ergonomic and
- environmentally friendly.

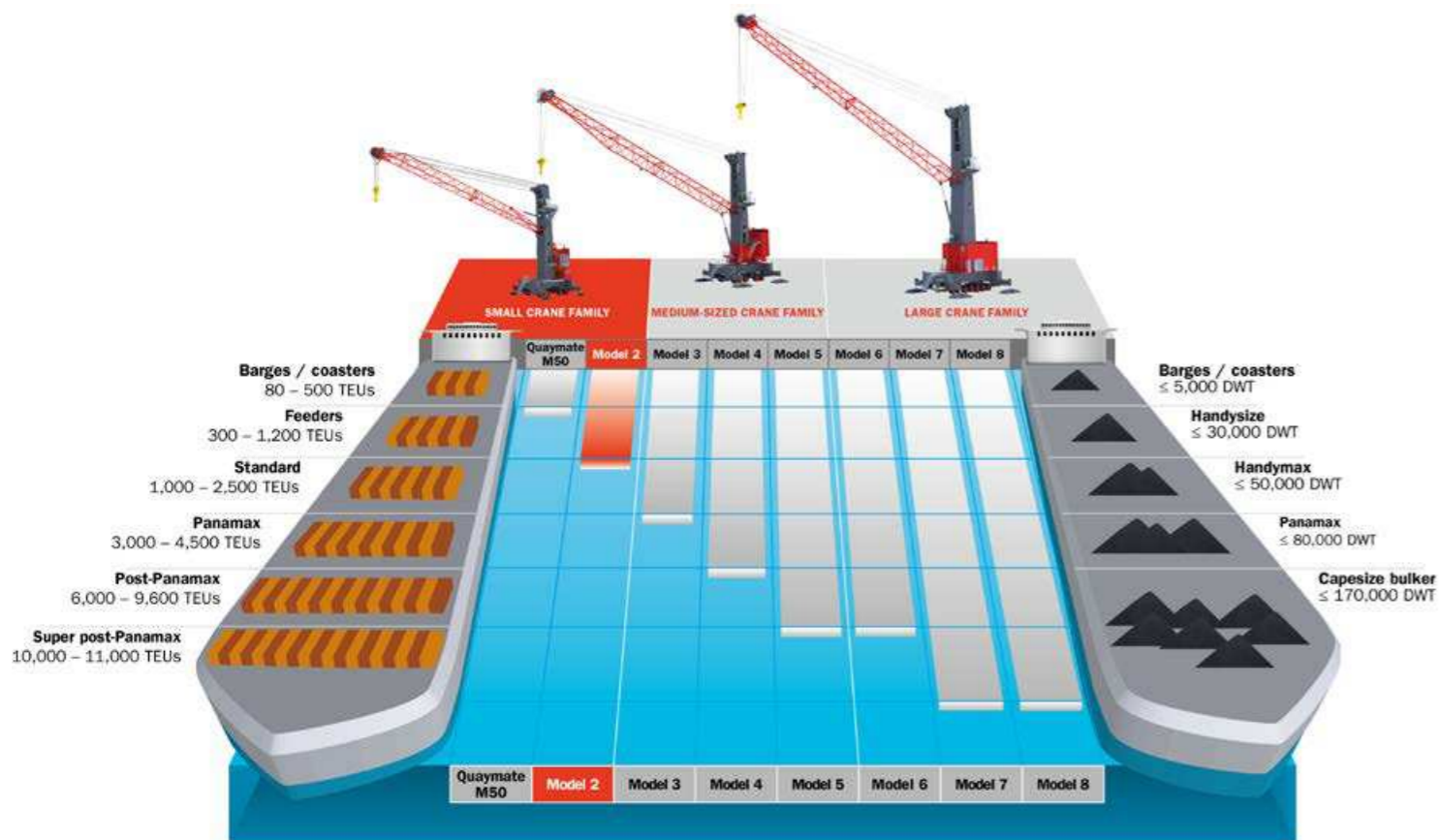

**MODEL 2 CRANE TYPES – HARD TO BEAT**

**THE RIGHT CRANE FOR EVERY SITE**

As the industry's pioneer, Konecranes created modular quayside and floating crane types based on mobile harbor crane technology to suit a wide variety of applications on quay, mid-stream and on the open sea.

**FOR FAST, EFFICIENT CARGO HANDLING**

Available in different crane types and variants, the Model 2 crane is a universally applicable machine which can quickly and efficiently handle cargo with a broad range of lifting gear.



**TOWER OPTIONS**

To suit individual requirements and applications:

- Short tower
- High tower

Crane types	Variants	Max. lifting capacities [t]			Max. hoisting speeds [m/min]		Max. radius [m]	
		63	80	80* 32**	85	100	38	40
G HMK (G HSK) (G HRK) (G HPK)	2204	✓				✓		✓
	2304		✓		✓			✓
	2305 B			✓		✓		✓

\* Heavy-load operation (top), four-rope grab operation (bottom)  
 \*\* A7 classification, 25-tonne grab curve in A8 classification. Please see the technical data sheet for complete data.

## MODEL 2 – G HRK RUBBER-TIRED PORTAL HARBOR CRANE

# BEST SOLUTION WHERE SPACE IS AT A PREMIUM

**Good drive-under capability is a crucial factor for cargo handling cranes in smaller terminals because it helps other vehicles to keep moving unhindered. As an operator, you know that standstill means reduced productivity.**

This is why Konecranes has chosen to take a bold new step with its Model 2. The G HRK rubber-tired portal harbor crane has a sufficiently generous portal to allow traffic to pass under it – yet it is compact enough to be highly manoeuvrable to all sides.

With its Konecranes Gottwald Model 2 Mobile Harbor Crane, TPS offers a long sought-after solution for your quay.

\*standard for the four-rope grab variant

### DESIGNED TO BE PRACTICAL

- Clear width: 9.5 m
- Clearance height: 6 m
- Proppable
- Four axle alignments with eight pairs of wheels, fifth axle\* optional
- Vertical compensation:  $\pm 250$  mm
- Stairway inside or outside (option)

### EASILY MANOEUVRABLE

- Maximum 40° steering lock
- Tight turning circle
- Excellent crab steering
- On-the-spot turning

### EASY TO DRIVE UNDER

- For one-way traffic
- Two-way truck movements
- Railways
- Also allows conveyor belts to be used

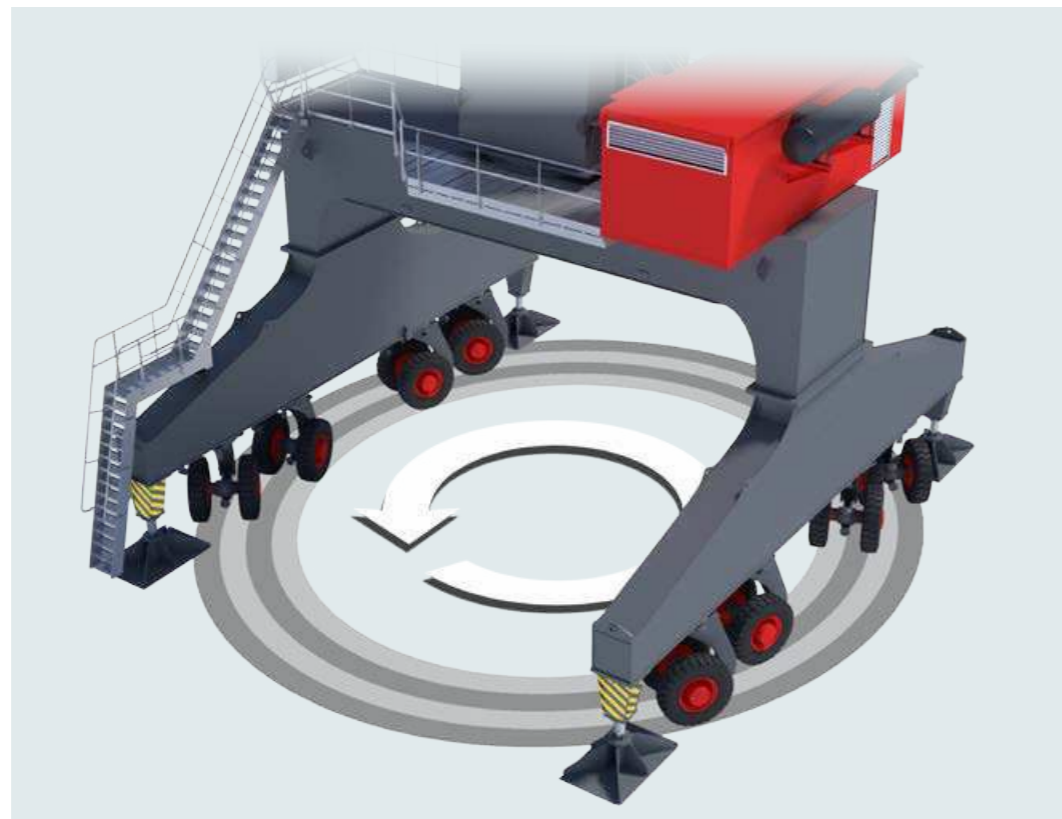

Steering lock of up to  $\pm 40^\circ$  (G HRK) enables tight turning circle and on-the-spot turning.

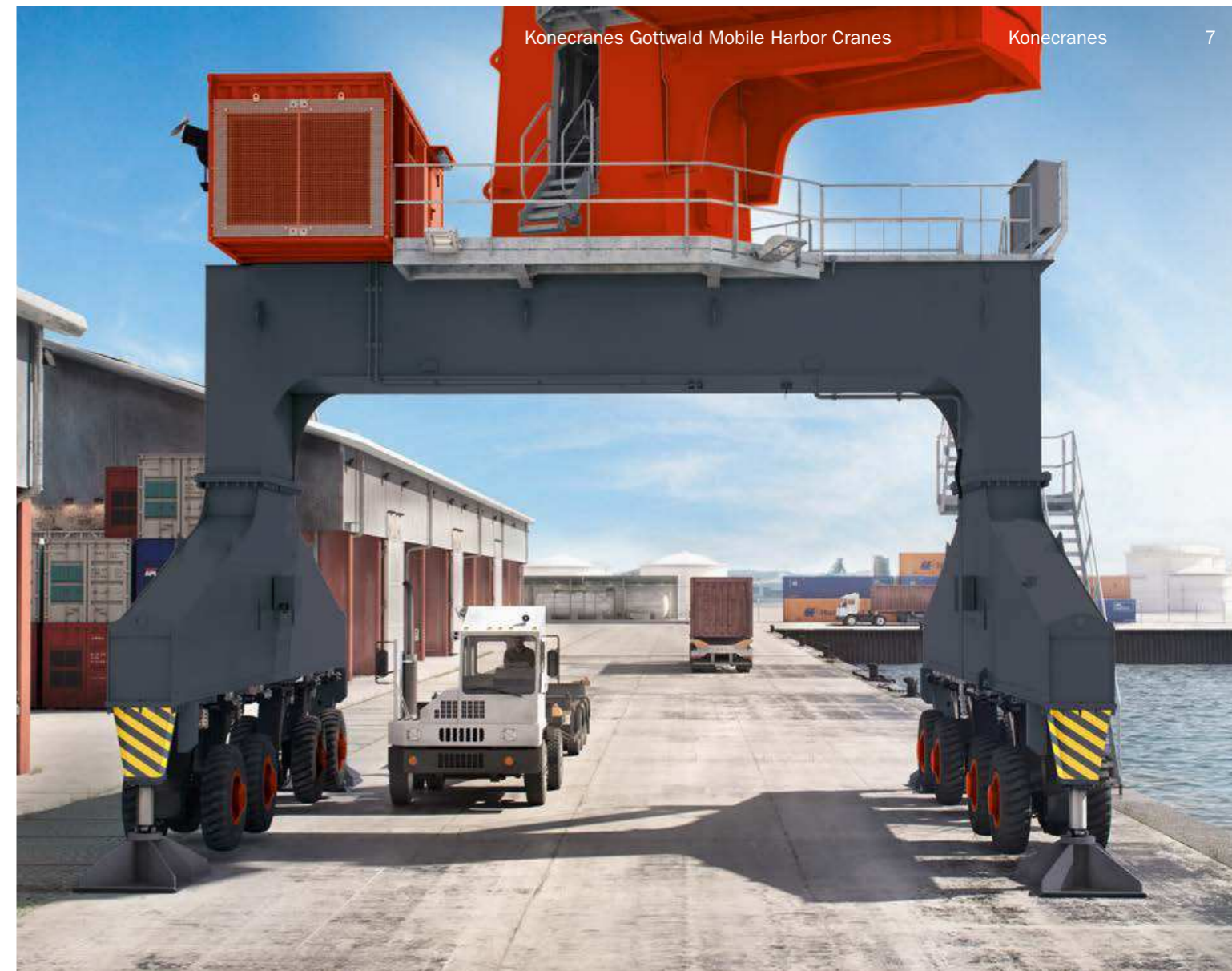

## INCREASED AXLE SPACING

Travel gear on the G HMK and G HRK with significantly increased axle spacing: much reduced quay loading when traveling the crane, optional equipment with a fifth axle alignment enables even more favourable load distribution.

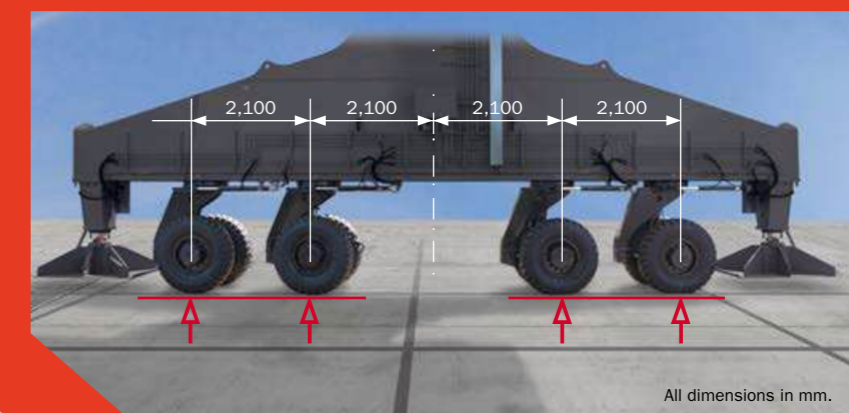

All dimensions in mm.

### MODEL 2 MOBILE HARBOR CRANES AT A GLANCE

# ALL-ROUND EXCELLENT DESIGN

#### CABLE REEL

Safe cable control and reduced cable loading due to torque-regulated cable reel.



#### TOWER HEAD

Ladders for safe ascent to the tower head. Extended platform for easy access to rope pulleys for maintenance work.

#### TOWER CAB

Ergonomically designed cab affords enhanced comfort.

High crane uptime through enhanced diagnostic via the Visumatic® crane management system.

Excellent view of the work site due to tower cab located high up on the tower. Even better view thanks to the forward-mounted cab (optional).



#### LIGHTING

Well-lit working site thanks to powerful lamps.



#### PROPPING SYSTEM

Proven H-type stabilizers including:

- automated propping system,
- stabilizer pads chosen for the particular conditions of the quay.



#### DRIVER CAB

Driver cab on the chassis (optional).

#### RUBBER-TIRED CHASSIS

Maintenance-free equalizer beams with vertical compensation of up to +/- 250 mm means the axle load is always evenly distributed.

Tight turning circle and crab steering provide excellent maneuverability.



CLEARLY ARRANGED AND EASILY ACCESSIBLE

## A CLOSER LOOK AT OUR INNOVATIVE TECHNOLOGY



### HYDRAULIC UNIT

- With main hydraulic pump and tank
- Supplies luffing cylinder, travel gear, stabilizers, steering and brake systems with hydraulic oil
- In a separate room on a platform at the rear of the tower



### ELECTRICS ROOM

- Housed in weatherproof, air-conditioned container
- Contains electrical equipment and control system
- Clearly divided into function groups
- Features diagnostics panel to facilitate troubleshooting



### DIESEL GENERATOR

- Housed in weatherproof, soundproofed container
- Features drive power based on crane variants and application
- Has sufficient power for all crane functions to be performed simultaneously and independently of each other

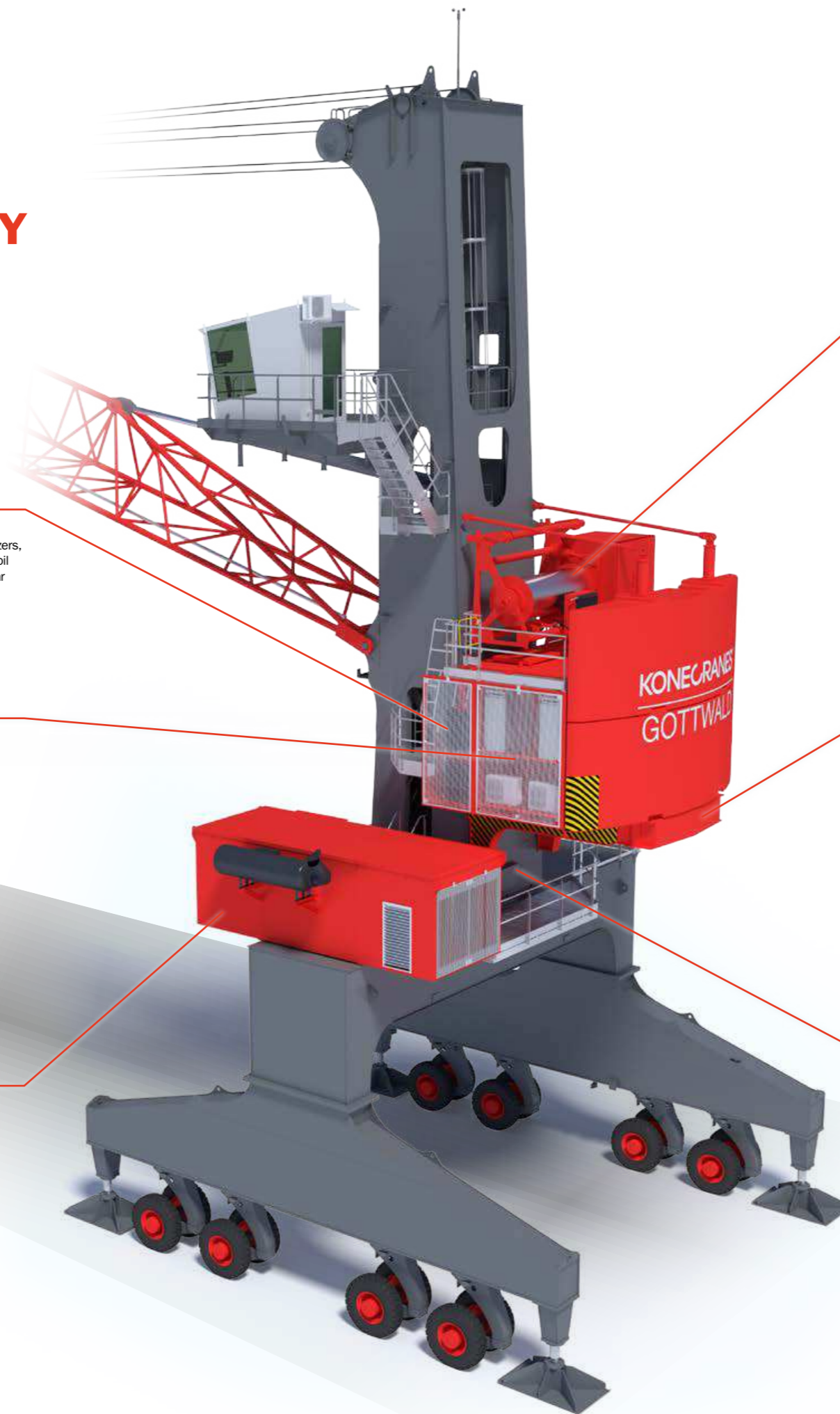

### HOISTS

- Easily accessible
- Proven planetary gear integrated in the drum with oil cooler
- 3-phase drive, smooth acceleration and deceleration of the hoisting motion
- Protective enclosure for drive unit and optional for hoist
- Second hoist for four-rope grab machines



### MACHINERY HOUSE

- Platform at the rear of the tower houses these units:
- electrical and hydraulic machinery,
  - hoist and
  - counterweights.

### SLEWING GEAR UNITS

- Slewing gear units designed as modular assemblies
- Drive units are performance-matched to the crane variant and applications
- Proven planetary gear
- 3-phase drive, smooth acceleration and deceleration of the slewing motion



### EXTERNAL POWER SUPPLY

Our cranes can make use of low or medium-voltage mains supplies. They may be equipped with the necessary units ex works or upgraded at a later date.

## 3-PHASE TECHNOLOGY

### Model 2 – with innovative electric-drive concept

With Model 2, Konecranes has expanded its electric drive concept and takes full advantage of technical progress and economic efficiency in 3-phase technology for drive motors.

The advantages of 3-phase power:

- regular maintenance of carbon brushes no longer required,
- gentle, power-dependent starts mean reduced power surges for the generator,
- easier application of energy-saving technologies because certain equipment is present from the start, for fitting ultracaps, for example,
- mitigated line-side harmonics in power supplies.

## DRIVE

# ELECTRICAL, EFFICIENT AND ECO-FRIENDLY

**The Model 2 mobile harbor crane is powered by electricity. The crane draws its power from the on-board diesel-powered generator or from the quayside mains supplying low or medium-voltage electricity.**

### GENERATING ELECTRICITY ON-BOARD

The diesel-powered generator features low fuel consumption thanks to its outstanding efficiency. Use of state-of-the-art dynamic brake resistors – standard on Konecranes Gottwald cranes – can provide savings in primary energy of up to 15% depending on operating conditions and crane capacity.

### EXTERNAL POWER SUPPLY

If used with electricity from the harbor mains, your Konecranes Gottwald crane offers:

- enhanced efficiency throughout the drive train,
- the opportunity to return electricity to the mains,
- help in reducing overhead costs,
- zero exhaust emissions in the terminal,
- reduced noise emissions,
- reduced servicing costs.

### HYBRID DRIVE

When generating power on-board, the crane is more efficient with the Konecranes Gottwald hybrid drive – a combination of the diesel-powered generator and electrostatic short-term storage media. The energy recovered from lowering and braking motions is stored in ultracaps, and is then available to the crane's electric circuits for the next work cycle. The result is a potential reduction in fuel consumption of up to 23% depending on operating conditions and crane capacity.



Electrostatic short-term storage media

## KONECRANES GOTTWALD MOBILE HARBOR CRANES

# SMART, USER-FRIENDLY, SAFE

The Model 2 mobile harbor crane is packed with smart technology. Konecranes focuses on safety and productivity for both the machine and the crane driver.

### AS STANDARD: ERGONOMIC, TOP-OF-THE-RANGE EQUIPMENT

The Model 2 mobile harbor crane includes user-friendly functions:

- comfortable, air-conditioned tower cab, with optional air-suspension seat for safe, comfortable work,
- Visumatic® crane management system with clearly arranged graphic symbols for intuitive operator guidance,
- camera on the boom tip for a close-up view of the work site via the monitor screen in the cab,
- ergonomically designed stairways with an inclination of 50° for comfortable, easy access to tower cab, machinery rooms and service points.

## MORE CONTROL – MORE EFFICIENCY

Many optional features enable customers to adapt their Konecranes Gottwald Model 2 crane to the exact conditions of use, these features include:

- radio remote control – to avoid repeated ascent to the tower cab during complex crane maneuvers,
- automatic point-to-point handling mode to provide efficient support for repetitive load moves,
- vertical lift assistant to stop the load swinging after being raised and prevent horizontal loads on the boom,
- tandem lift assistant permits use of full lifting capacities and control of two cranes by only one operator,
- grab fill level control to reduce overload cut-outs and to improve the bulk handling performance,
- hold totalization feature for register and record bulk handling rates per hold and in total,
- web-based information and diagnostics system to record operating data and provide access to service data.



### EVERYTHING UNDER CONTROL

Intuitive operation through user-friendly human-machine interface.



**HIGHLY EFFICIENT SOLUTIONS**

**PERFECTLY INTEGRATED HANDLING**

**Konecranes offers a comprehensive range of equipment for all points along the logistics chain – to provide integrated handling solutions from a single source.**

As an experienced port solutions provider, we meet the needs of the entire logistics chain and its interfaces – whether in container, general cargo or bulk handling.

**THE RIGHT CHOICE – FROM THE START**

We also offer planning and advisory services on all aspects of terminal investments and expansion projects. To help you, we employ state-of-the-art software solutions including simulation and emulation specifically for container handling.

**BULK HANDLING**

Konecranes also enhances bulk handling capability by offering:

- consultancy services and
- software designed specifically for bulk terminals.

Konecranes Gottwald Mobile Harbor Cranes are suitable for a complete range of cargo handling applications and are adapted to specific quay infrastructures. Our ever-expanding product range also includes software developed specifically for bulk terminals.



**SOLUTIONS FOR CONTAINER TERMINALS**

We offer a comprehensive range of container handling equipment for the entire logistic chain.



**SOLUTIONS FOR GENERAL AND PROJECT CARGO**

Model 2 mobile harbor cranes handles palletized fruits efficient thanks to high working speeds.



For limited and missing quay infrastructures Konecranes offers floating cranes.

**SOLUTIONS FOR CHALLENGING QUAY INFRASTRUCTURES**

Model 2 is available as portal harbor crane with customized portals in regards to height, span and quay loading.



**YOUR MODEL 2 MOBILE HARBOR CRANE IS IN THE BEST HANDS WITH US**  
**COMPREHENSIVE SERVICE**

**During the development of our Model 2 mobile harbor cranes and their variants we were already thinking about ease of maintenance. The robust machines are user-friendly thanks to easily accessible maintenance points. Our expertise is complemented by the use of components from globally renowned manufacturers.**

**WE MAINTAIN AVAILABILITY**

We contribute to maintaining the availability of your Model 2 mobile harbor crane. Our global service organization is local to you in all time zones, and offers you expertise in maintenance and repair in combination with fast delivery of spare parts.

**WE KEEP THE VALUE OVER MANY YEARS**

We are the right choice to provide support for your Model 2 mobile harbor crane because we built it and therefore know it best. With our comprehensive service portfolio, your crane remains state of the art, its service life increases and it maintains its value over many years.



This publication is for general informational purposes only. Konecranes reserves the right at any time, without notice, to alter or discontinue the products and/or specifications referenced herein. This publication creates no warranty on the part of Konecranes, express or implied, including but not limited to any implied warranty or merchantability or fitness for a particular purpose.



Konecranes is a world-leading group of Lifting Businesses™, serving a broad range of customers, including manufacturing and process industries, shipyards, ports and terminals. Konecranes provides productivity enhancing lifting solutions as well as services for lifting equipment of all makes. The Group has 18,000 employees at 600 locations in 50 countries. Konecranes is listed on Nasdaq Helsinki (symbol: KCR).

© 2017 Konecranes. All rights reserved. 'Konecranes', 'Lifting Businesses' and  are either registered trademarks or trademarks of Konecranes.

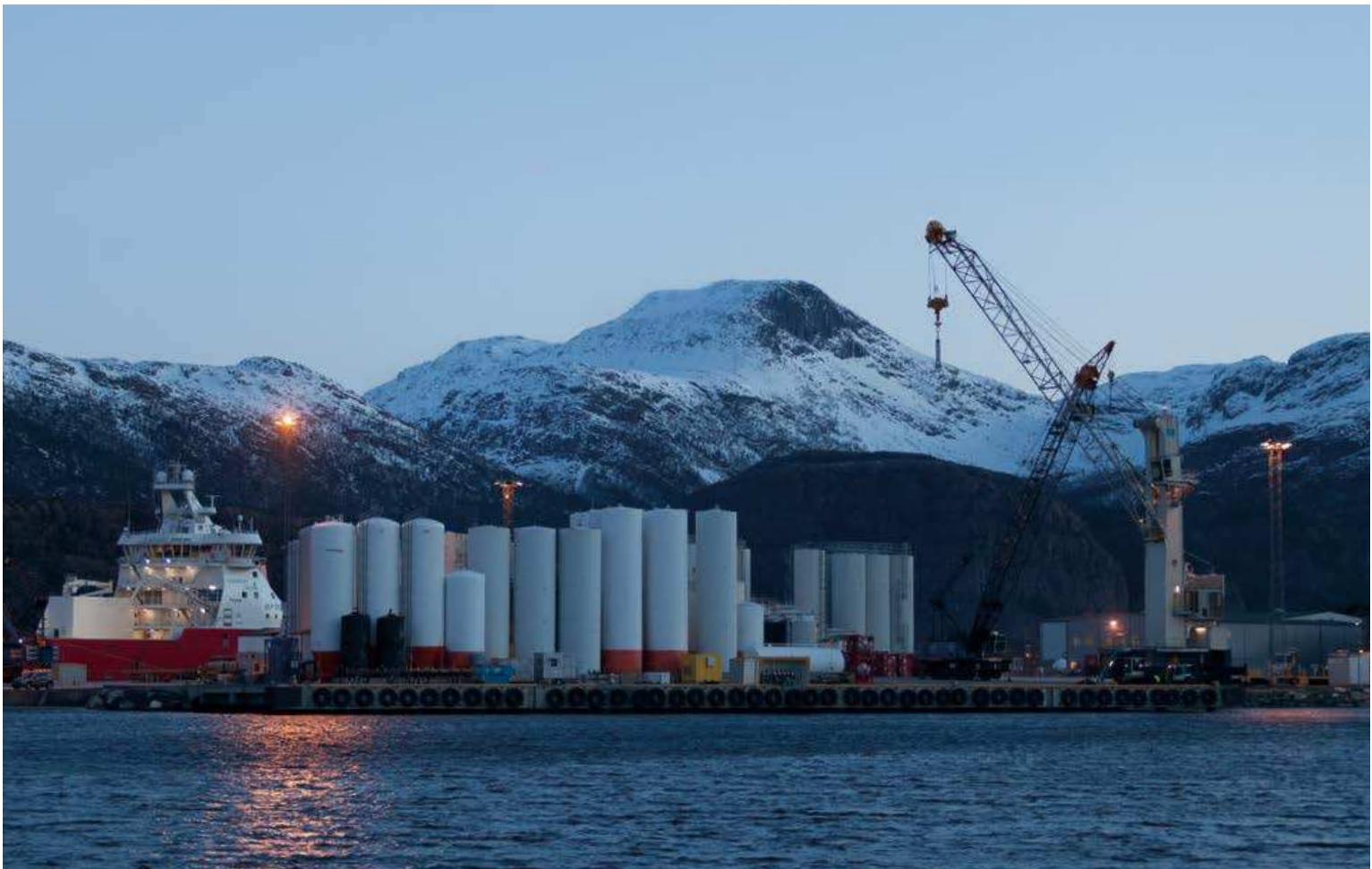

[konecranes.com](http://konecranes.com)

Courtesy of CraneMarket.com