

DX50



KOMATSU[®]



The Forklift With Proven Ability.™

PNEUMATIC TIRE FORKLIFT

15,400 – 18,000 LBS. CAPACITY | DIESEL

"Reducing Total Operating Costs" with Komatsu Innovative Technologies

The fusion of advanced engine technologies and Komatsu's unique hydraulic system enables the new DX50 Series to achieve a significant reduction in total operation costs and facilitates superior working performance. Our innovative machines challenge the conventional concept of the forklift.

Komatsu's Hydraulic System and the NEW Diesel Engine Reduce Fuel Consumption



In order to minimize engine loading, the new DX50 has adopted Komatsu's unique open-center load moderating (OLMS) hydraulic system, and the compact 3.3-liter diesel engine to achieve superior performance and up to a 20% reduction in fuel consumption.

Komatsu's Unique OLMS Hydraulic System Contributes To Lower Fuel Consumption

As engine speeds change, the engine RPM sensing control pump detects engine revs and then controls the oil feed to reduce the load on the engine. This unique hydraulic system offers optimized balancing of traveling and loading work, while delivering increased hydraulic efficiencies in the most demanding applications.

Fuel Consumption
Max. 20% savings

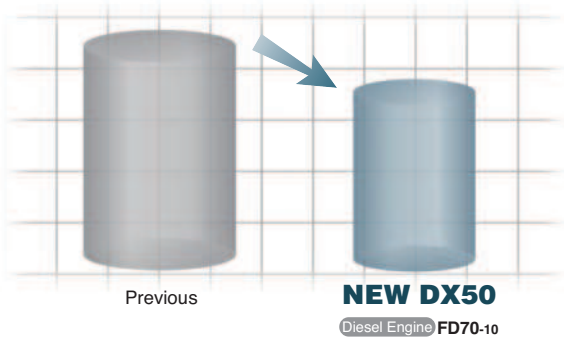

Komatsu tested data, comparison with FD70-8. The results may vary depending on conditions.

- Optimally controlled hydraulic oil results in;
- Optimized balancing of traveling and loading work
 - Lower fuel consumption with OLMS and the new compact 3.3 liter diesel engine.

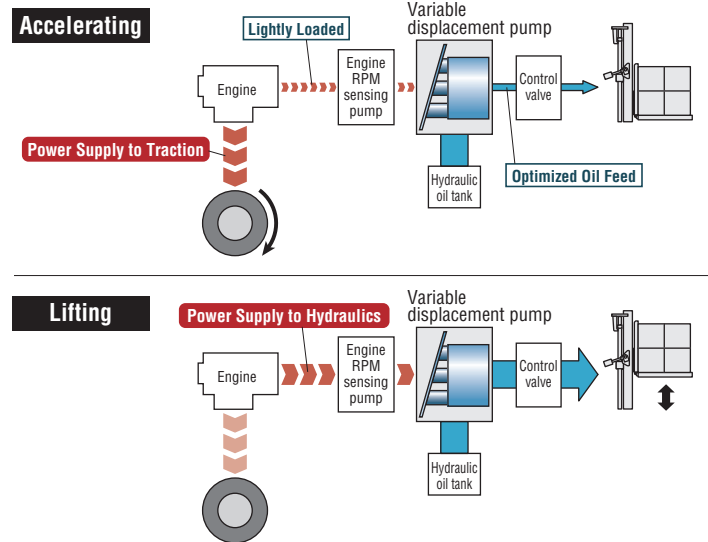

Greatly Reduced Total Operating Costs

The standard sealed wet disc brake system is designed to withstand 10,000* hours of operation without maintenance, thereby eliminating downtime and the added maintenance costs of frequent brake shoe replacement. The engine oil replacement interval has been extended to 500 hours, which reduces oil costs. The reduced maintenance costs and significant fuel savings provides a total operating cost reduction of about 14% over eight years of usage.

*A periodic check and oil replacement are necessary.

Running cost (Accumulated costs for 8 years)

Assuming FD70-8 as 100%;



Total operating cost (*Image)

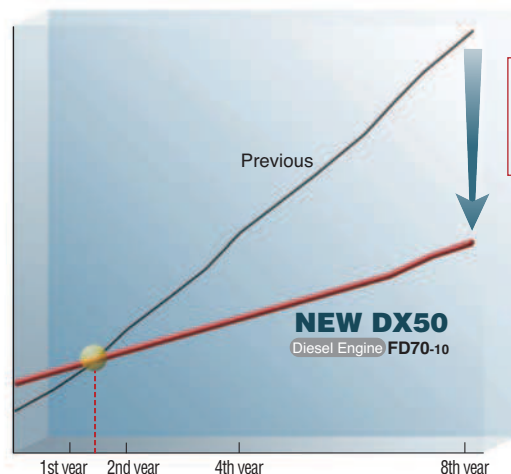

Total operating cost
Approx. 14% savings
(8 years)

Komatsu tested data, comparison with FD70-8 model. Operation hours: 5 h/day, 25 days/month (Total: Approx. 1500 h/year), Maintenance intervals to manufacturer's recommendation. The results may vary depending on conditions.

Advanced Technology Offers Reduced CO₂ Emissions



The new DX50 Series feature the SAA4D95LE-5-A compact 3.3 liter engine in combination with Komatsu's efficient OLMS hydraulic system to enable the reduction of CO₂ emissions by approximately 7.8 tons annually.

Annual CO₂ emissions
About **7.8** tons reduction

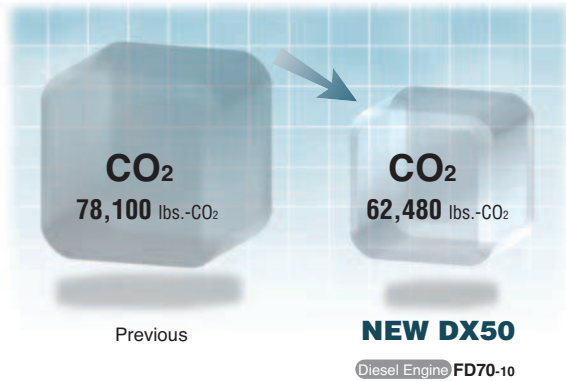

Komatsu tested data, comparison with FD70-8 model.
The results may vary depending on conditions.

A technologically advanced Diesel Engine that Conforms to the Latest EPA Emission Regulations

Low fuel consumption and low environmental impact are enabled by elimination of excess combustion and the use of the combined technologies of the high pressure common rail system, electronic control system, new combustion system and air to air charge air cooling system.

EPA Tier 3 / EU Stage IIIA Emission Compliant

ecot3
ecology & economy - technology 3



SAA4D95LE-5-A

Displacement:

3.3 liter

Rated Output:

92.5 HP @ 2,250 rpm

Maximum Torque:

253 lb.-ft. @ 1,600 rpm



Superior "Productivity" and "Reliability" Satisfy Demanding Operational Needs

Durable Wet Disc Brakes to Withstand Severe Conditions



The wet disc brake system is sealed with oil to block dust penetration, providing durable, water resistant and fade resistant characteristics. Smooth, stable braking provides "Productivity" and "Reliability" in demanding operations.



A Cooling System to Achieve Increased Braking Stability

The oil in the wet disc brake system is circulated through the brake oil cooler. This mechanism ensures stable braking under a heavy work load and prevents deterioration of the braking force that could be caused by raised oil temperatures.

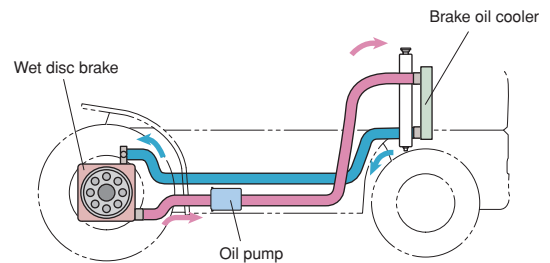

- Steady braking is always achieved.
- Overheating of the brakes is prevented.
- Downtime and maintenance costs are reduced.

First-class Productivity is Achieved

First-class Cycle Time

The new DX50 Series utilizes a technologically advanced, compact 3.3-liter engine in conjunction with Komatsu's advanced OLMS hydraulic system. This advanced design achieves high productivity and first class cycle times.

- The NEW DX50 Series achieves high productivity equivalent to the previous DX20 Series.

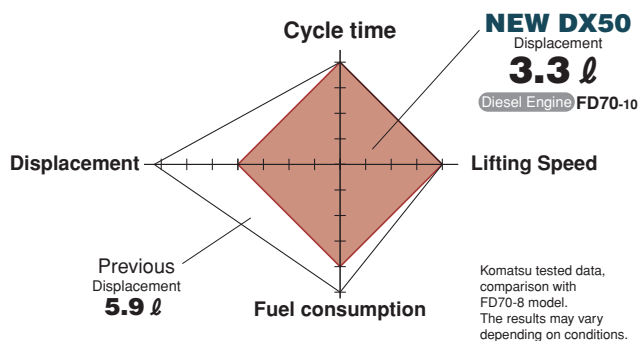

● **Lifting Speed** (Loaded)
Diesel Engine FD70-10
88.5 fpm

● **Traveling Speed** (Unloaded)
Diesel Engine FD70-10
19.3 mph

Fully Hydrostatic Power Steering for Superb Maneuverability

The FHPS (Fully Hydrostatic Power Steering) system facilitates fully stationary steering as well as switchback operations using the small diameter steering wheel. The system has a superior response capability so that the operator can maneuver easily with a load even in a tight area.

The 18,000 lb model offers a significant size reduction

The 18,000 lb. model features a shorter wheelbase and swift mobility while maintaining the power and speed capable of achieving high productivity. The DX50 18,000 lb. model is an ideal choice for confined spaces.

- **Length**
193 in.
201 in. [Previous 18,000 lb. model]
- **Width**
81 in.
83 in. [Previous 18,000 lb. model]
- **Turning radius**
136 in.
142 in. [Previous 18,000 lb. model]

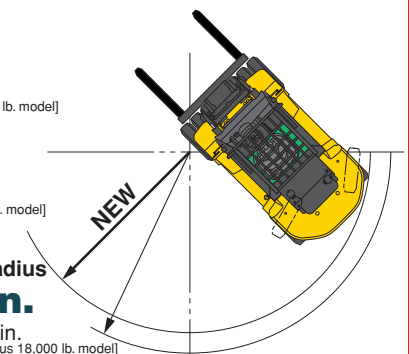

Excellent Durability To Handle Demanding Work Cycles

Rugged Design with High Rigidity

The high rigidity mast, frame, front and rear axles ensure outstanding reliability even when performing heavy-duty work.

[Mast]

A heavy mast rail profile for excellent rigidity.

[Frame]

The successful high rigidity structure of previous models is adopted.

[Front axle]

New field proven design adopted from Komatsu Wheel Leader Construction Equipment.

[Rear axle]

The durability of the power steering cylinder is improved.

Improved Reliabilities for the Hydraulic and Electrical Systems

The main hydraulic pipe connectors are face-sealed using O-rings. Waterproof connectors are provided to the main harnesses and the system controller in order to provide higher resistance to water and dust. Hydraulic and electrical piping systems are in separate configurations to improve the reliability and servicing.

Engine Protection Systems To Keep the Engine in the Best Operating Condition

The electronic engine controls upgrade the performance of the engine protection (fail-safe functions).

- **Trouble diagnosis:**
Engine malfunctions are automatically detected and an alarm lamp blinks.
- **Overheating prevention:**
The engine output and RPMs are reduced when the coolant temperature exceeds limits.
- **Automatic engine warm-up:**
The RPMs are accelerated to warm up the engine at low temperatures.
- **Automatic air pre-heating:**
The engine is automatically pre-heated when starting at low temperatures.



Engine failure indicator



Careful Designs Make Serviceability Easier

Filter Layout Optimized for Improved Serviceability

A fully-opening floor plate.

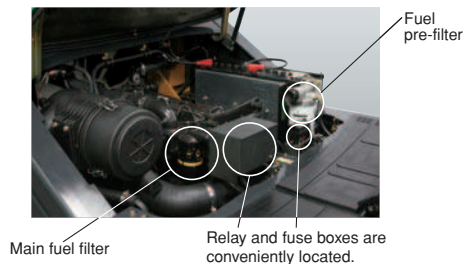

Easy Radiator Cleaning



Wide Opening Engine Hood with a Lock for Easy Servicing

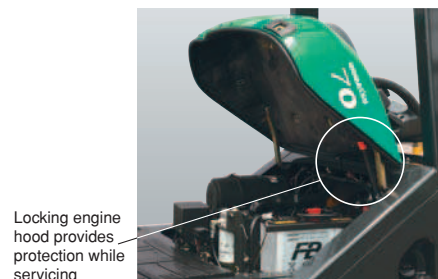

Advanced Design in Pursuit of "Safety and Comfort"

Effective Risk Reduction Systems

KOPS Plus - "Komatsu Operator Presence System"

The DX50 features KOPS Plus to protect people and equipment if the operator leaves the seat. If the seat is vacant for more than three seconds, KOPS Plus automatically locks out all lift, lower, tilt and travel functions. The operator must return to the seat to unlock the system. A flashing yellow warning light alerts the operator when KOPS Plus is activated. In addition, the DX50 forks cannot be lowered with the key in the off position.

*The traveling interlocking function only disengages traction and does not automatically apply the brakes.
*KOPS Plus - "Komatsu Operator Presence System" ISO3691-1 compliant



KOPS Plus Hydraulic Lock Indicator



KOPS Plus is activated when the operator leaves the seat for more than three seconds.

A Neutral Safety Function To Prevent an Inadvertent Start

The engine cannot be started unless the F-R switch is in the neutral position.



Neutral indicator for at-a-glance information

Parking Brake Alarm

If the operator fails to engage the parking brake, an alarm will sound.



A double acting type brake lever prevents mishandling

ISO-Compliant Enhanced Overhead Guard for Operator's Protection



Greater Operator Comfort and Reduced Fatigue In Even The Toughest Applications

Full Suspension Seat and Floating Cab Structure Absorb Vibrations

The deluxe full suspension seat features improved vibration resistance and reduced stress on the body. The floating cab structure enables the entire cab to be isolated from the frame and the rubber cushioning of the engine mounts reduces the vibrations transmitted from the engine and road surface. The overall design concept is operator and load friendly.

- Six-step reclining backrest
- 6.7" slide distance backward and forward
- Seat cushion adjustment dial
- Retractable seat belt



Comfortable Braking with the Organ-type Pedal

The organ-type pedal allows an operator to control braking comfortably without lifting the heel from the floor.



Low Noise Design

The low-noise design of the compact engine reduces unpleasant noise levels during operation.

DX50 Series Specifications

GENERAL			FD70T-10	FD80T-10
Power Type		1	Diesel	Diesel
Operation Type		2	Sit-Down	Sit-Down
Capacity @ 24 in. (600 mm) load center *	lbs. (kg)	3	15,400 (7,000)	18,000 (8,000)
Load Distance - Front Axle Center to Fork Face	in. (mm)	4	23 (585)	25 (635)
Wheelbase	in. (mm)	5	90.6 (2,300)	90.6 (2,300)
WEIGHT				
Service weight (includes 2-stage std. mast & forks)	lbs. (kg)	6	20,380 (9,245)	24,050 (10,910)
Axle Loading	Loaded	Front	lbs. (kg)	7 31,590 (14,330)
		Rear	lbs. (kg)	8 4,220 (1,915)
	Unloaded	Front	lbs. (kg)	9 8,210 (3,725)
		Rear	lbs. (kg)	10 12,170 (5,520)
10			12,170 (5,520)	14,640 (6,640)
TIRE				
Tire type		11	Pneumatic	Pneumatic
Tire size, front		12	8.25 - 15 - 14PR (I)	8.25 - 15 - 18PR (I)
Tire size, rear		13	8.25 - 15 - 14PR (I)	8.25 - 15 - 18PR (I)
Number of wheel, front / rear	x= driven	14	4x / 2	4x / 2
Tread (center of tires)	Front	in. (mm)	15 57.9 (1,470)	60.6 (1,540)
	Rear	in. (mm)	16 64.6 (1,640)	64.6 (1,640)
DIMENSIONS				
Tilting angle, 2-stage (FV) masts, forward / backward	deg.	17	6 / 12	6 / 12
Mast height, lowered (2-stage std. mast)	in. (mm)	18	101.8 (2,585)	106.7 (2,710)
Free lift height (2-stage std. mast)	in. (mm)	19	8.7 (220)	8.7 (220)
Mast height, extended (2-stage std. mast) †	in. (mm)	20	171.3 (4,350)	171.3 (4,350)
Maximum fork height (2-stage std. mast) **	in. (mm)	21	118 (3,000)	118 (3,000)
Height overhead guard	in. (mm)	22	96.1 (2,440)	96.1 (2,440)
Length, with Std. Forks	in. (mm)	23	188.4 (4,785)	192.5 (4,890)
Length to fork face (2-stage mast)	in. (mm)	24	140.4 (3,565)	144.5 (3,670)
Overall width, at drive tires (single)	in. (mm)	25	78 (1,980)	80.7 (2,050)
Forks, thickness x width x length	in.	26	2.6 x 5.9 x 48	2.6 x 6.7 x 48
Forks, thickness x width x length	mm	27	65 x 150 x 1,220	65 x 170 x 1,220
Carriage width / ITA Class	in. (mm)	28	66.5 (1,690) / IV	70.9 (1,800) / IV
Ground clearance, under mast	in. (mm)	29	8.7 (220)	9.3 (235)
Ground clearance, center of wheelbase	in. (mm)	30	11.6 (295)	11.6 (295)
Right angle stacking aisle ††	in. (mm)	31	154.9 (3,935)	160.8 (4,085)
Turning radius, outside	in. (mm)	32	131.9 (3,350)	135.8 (3,450)
PERFORMANCE				
Travel speed, forward, loaded - 1st / 2nd	mph (km/h)	33	6.8 / 18 (11 / 29)	6.8 / 16.2 (11 / 26)
Travel speed, forward, unloaded - 1st / 2nd	mph (km/h)	34	7.5 / 19.3 (12 / 31)	7.5 / 19.3 (12 / 31)
Lifting speed, loaded / unloaded (2-stage mast)	fpm (mm/s)	35	89 (450) / 98 (500)	79 (400) / 89 (450)
Lowering speed, loaded / unloaded (2-stage mast)	fpm (mm/s)	36	94 (480) / 98 (500)	91 (460) / 98 (500)
Maximum drawbar pull, loaded	lbs. (kN)	37	9,890 (44)	9,890 (44)
Maximum gradability	%	38	29.0	24.0
Service brake, operation/control		39	Foot / Hydraulic	Foot / Hydraulic
Parking brake, operation/control		40	Hand / Mechanical	Hand / Mechanical
Steering, type		41	FHPS	FHPS
Battery / Voltage / Capacity at 5-hour rating	V / Ah	42	24 / 52	24 / 52
DRIVE				
Engine Manufacturer / Engine model		43	Komatsu SAA4D95LE-5-A	Komatsu SAA4D95LE-5-A
Rated output (SAE Net)	HP (kW) @ rpm	44	93 (69) @ 2,250	93 (69) @ 2,250
Maximum torque (SAE Net)	lb-ft (Nm) @ rpm	45	253 (343) @ 1,600	253 (343) @ 1,600
No. of cylinder / displacement	cu. in. (cm ³)	46	4 / 199 (3,260)	4 / 199 (3,260)
Fuel tank capacity	U.S. gallons (liters)	47	37 (140)	37 (140)
OTHER				
Relief pressure, maximum	psi (bar)	48	2,600 (181)	2,600 (181)
Transmission		49	TORQFLOW	TORQFLOW

NOTE: Most values shown in this publication are rounded. Therefore, direct conversion between metric and English or Imperial may be slightly different from those shown. The performance of machines is affected by the condition of the truck and how it is equipped, as well as the nature and condition of the operating area. If these specifications are critical or if your needs exceed the specifications shown here, discuss the proposed application with your authorized dealer.

*Optional masts, attachments, longer load dimensions, and higher lifting heights may result in downrating of the capacity. Contact your authorized dealer.

**Other mast heights available. See MAST DATA chart for other standard mast heights. Contact your authorized dealer.

†Includes 48-inch (1,220 mm) high load backrest. Contact your authorized dealer.

††Add load length plus clearance

Dimensions

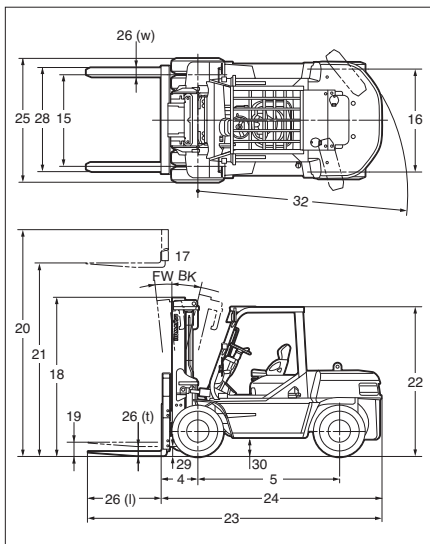

Load capacity curve

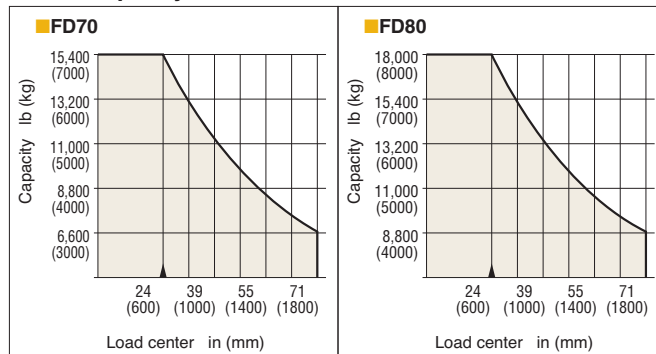

Building on our 80 year history of superior engineering, the DX50 Series delivers on productivity, reliability, and lower life-cycle costs while working your most demanding applications.

DX50 Series

PNEUMATIC TIRE FORKLIFT

STRONG CUSTOMER SATISFACTION

Komatsu Forklift has a strong corporate commitment to produce, deliver and support quality products, and we have always made customer satisfaction our top priority. We will work to the best of our ability to help you maximize your operation's productivity while minimizing costs.

QUALITY PRODUCTS & SERVICES

Komatsu Forklift offers an expanding product line of over 120 electric and internal combustion engine forklift models with capacities from 2,000 to 35,000 pounds. We back them with a complete warranty program, superior service, and genuine OEM parts.

CONTACT YOUR DEALER TODAY

Your nearby Komatsu Forklift dealer is ready to assist you. Ask about financing and leasing programs that can be tailored to your business plan. Forklifts for your specific applications and workplace are waiting for you now.

KOMATSU DEALER NETWORK

Komatsu Forklift has over 195 dealer locations throughout the United States, Canada, Mexico, the Caribbean, and Central and South America. Komatsu dealers are staffed with dedicated teams of professionals who are trained to meet your forklift needs.

THE KOMATSU HERITAGE

As part of the Komatsu family, we have a proud heritage of excellence in equipment design and manufacturing. Since 1921 Komatsu has been a global leader in the construction and mining equipment industry. And since 1945, we have built upon that heritage by producing innovative, high-quality, durable forklifts to meet and exceed the needs of our customers.



KOM93-01

©2011 Komatsu America Corp.

Printed in USA

D07(500)CCI

7/11 (EV-1)

KOMATSU[®]

www.KomatsuAmerica.com

www.KomatsuForkliftUSA.com

Komatsu America Corp. is an authorized licensee of Komatsu Ltd. Materials and specifications are subject to change without notice. Photos may include optional equipment.

KOMATSU is a registered trademark of Komatsu Ltd., Japan
Courtesy of CraneMarket