



Decomposition transport list

KA-3000RX

1. Carrier	9
2. Slewing upper structure	10
3. Counter weight	12
4. Boom	15
5. Boom heavy load lifting equipment	17
6. SL jib	18
7. Heavy lift jib	19
8. Hook	25
9. Overhoisting detector	26
10. Tools	28

1. Carrier (951Q-0002-0E)

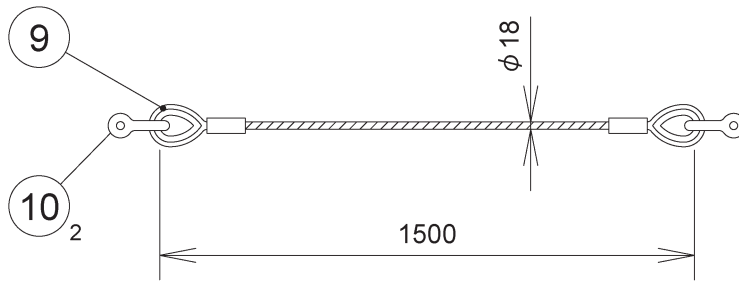
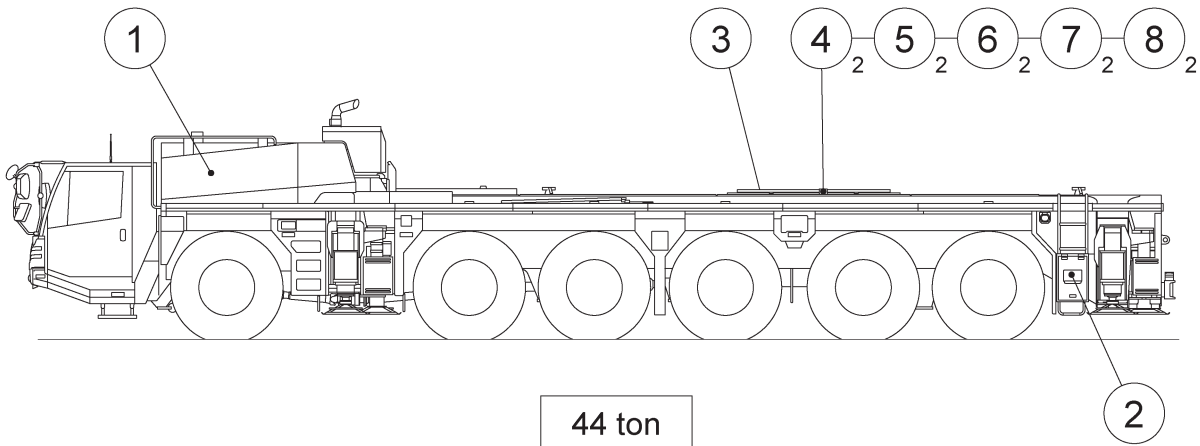

Hook fastening rope for work site driving (optional)

No.	Name	Q'ty	Note (Part No.)
1	Carrier	1	
2	Toolbox	1	
3	Cover	1	(741-20210000)
4	Ring	2	(821-20221000)
5	Bolt	2	M33 (821-20222000)
6	Bolt	2	M10 (001-10310045)
7	Spring washer	2	For M10 (001-12110002)
8	Nut	2	For M10 (001-13210000)
9	Wire rope ($\phi 18 \times 1500$)	1	(Optional) (741-84401000)
10	Shackle (for 2.5ton)	2	(Optional) (001-50720000)



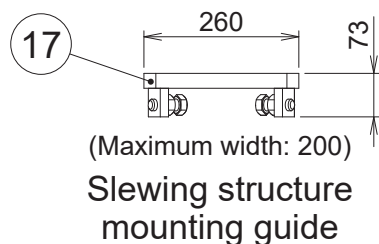
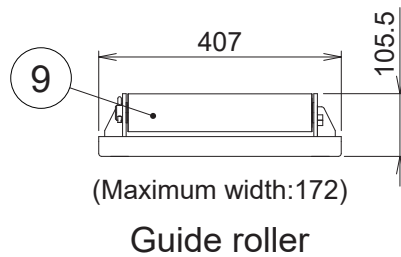
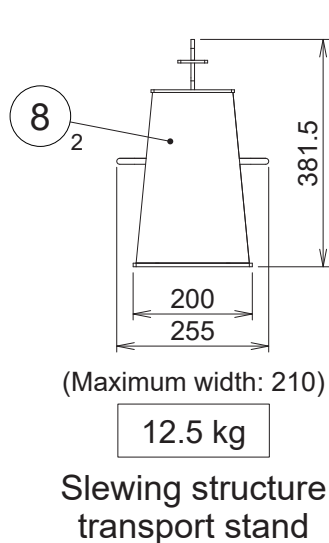
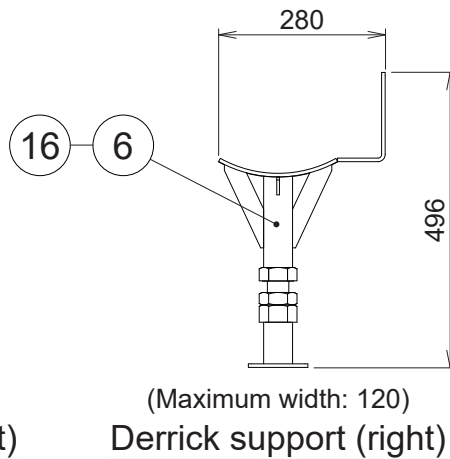
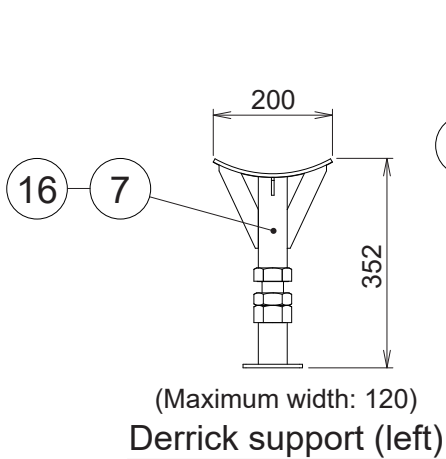
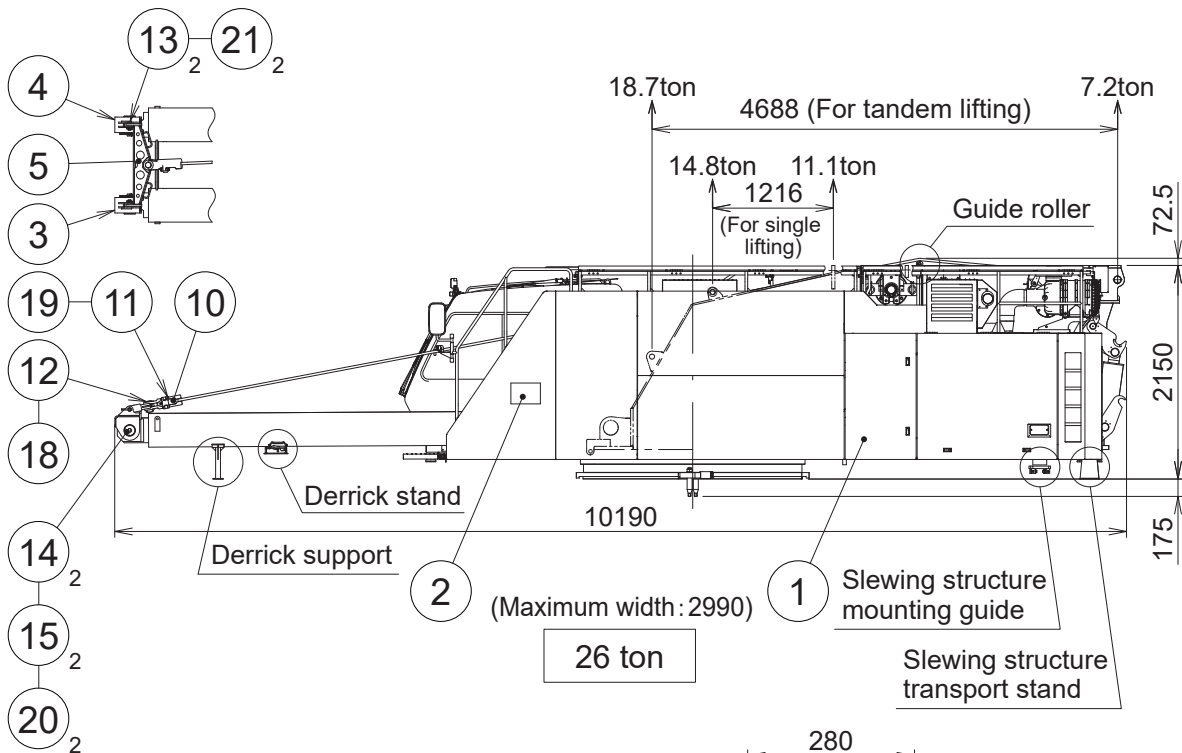

2. Slewing upper structure (951Q-0003-0E)

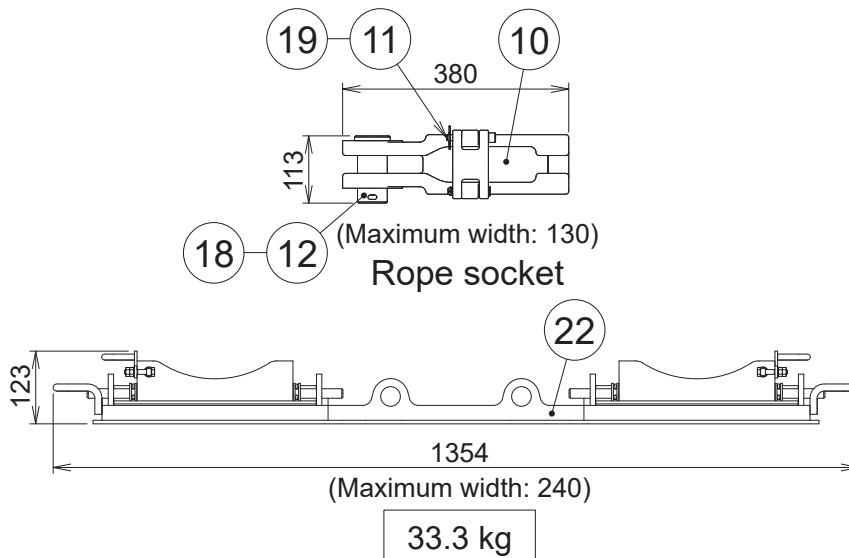

1702121-001-0E

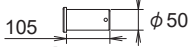

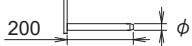
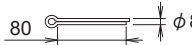
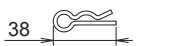
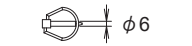
Derrick stand
(optional)

No.	Name	Q'ty	Note (Part No.)
1	Slewing upper structure	1	
2	Name plate	1set	
3	Stowage bracket (left)	1	(741-44101002)
4	Stowage bracket (right)	1	(741-44102002)
5	Stowage hanger	1	(741-44103010)
6	Derrick support assembly (right)	1	(741-44110000)
7	Derrick support assembly (left)	1	(741-44111000)
8	Stand	2	(For slewing structure transport) (741-44106001)
9	Guide roller assembly	1	
10	Rope socket assembly	2	
11	Pin	2	 (741-84109000)
12	Pin	2	 (752-84108003)
13	Pin	2	 (872-44047001)
14	Pin	2	 (951-44003010)
15	Pin	2	 (951-44057000)
16	Rubber	2	(951-44053000)
17	Guide assembly	1	(For mounting the slewing structure)
18	Split pin	2	 (001-20208080)
19	Snap pin	2	 (001-20410000)
20	Quick pin	2	 (001-20525000)
21	Quick pin	2	 (001-20540000)
22	Derrick stand assembly	1	(Optional)

1702121-002-0E

3. Counterweight (951Q-0004-1E)

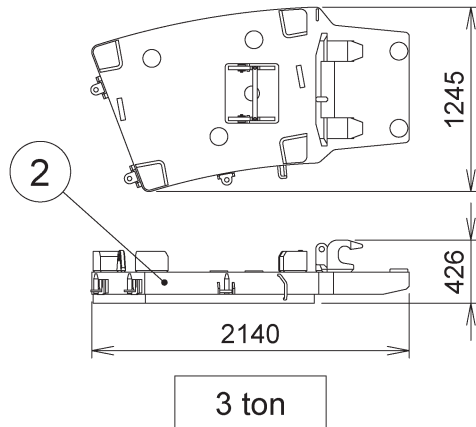
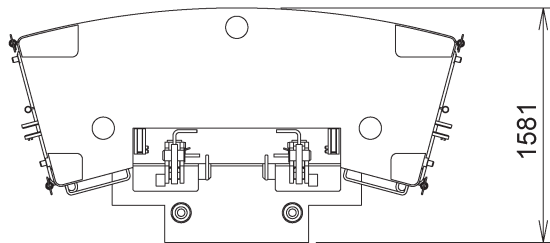
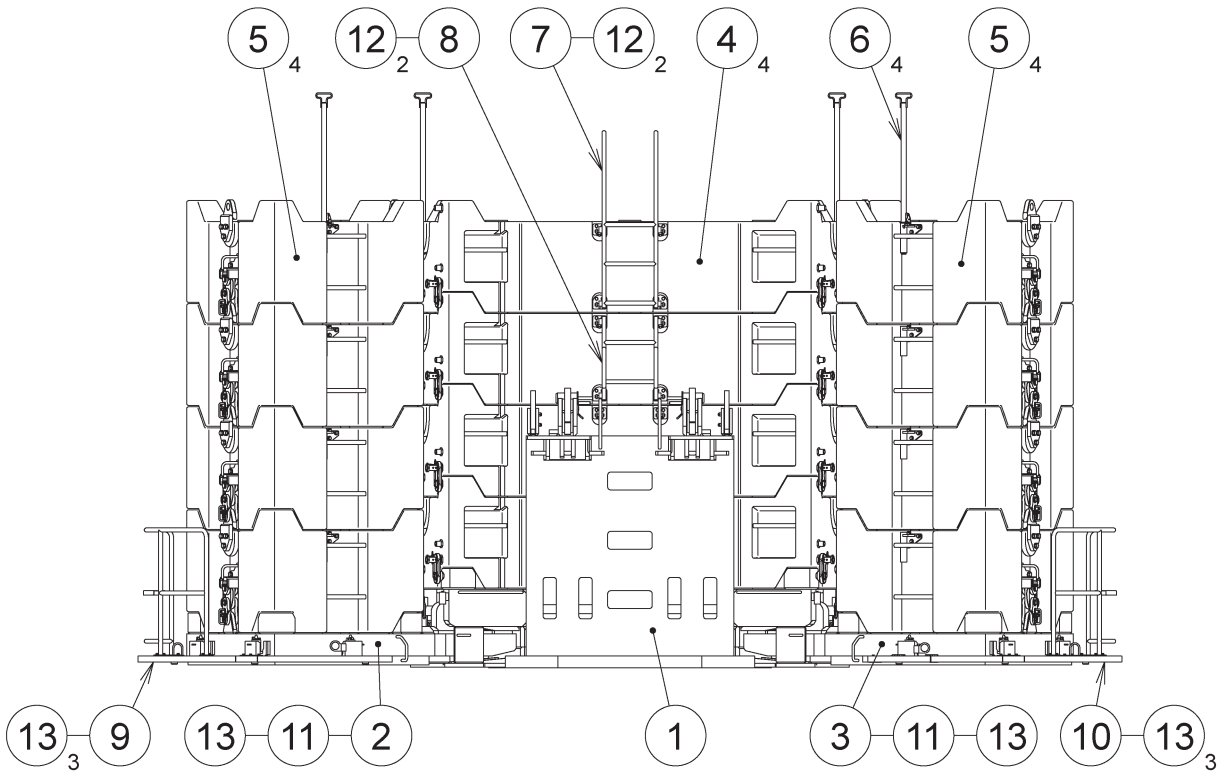

Side base weight (right)

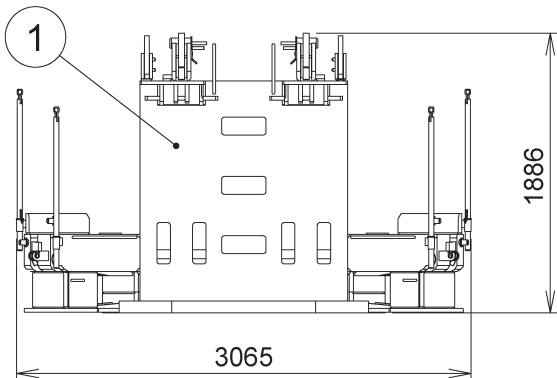

Base weight

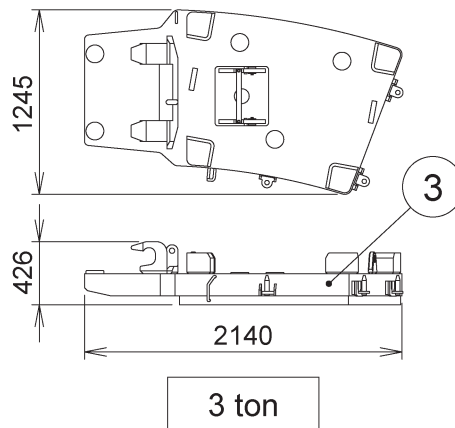

Side base weight (left)

1702061-004-0E

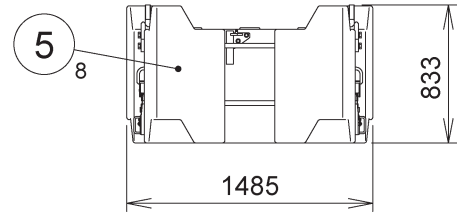
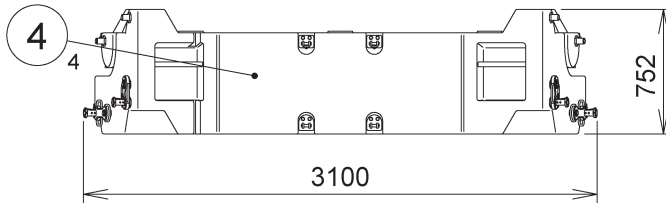
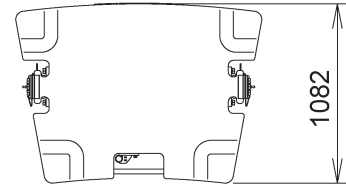
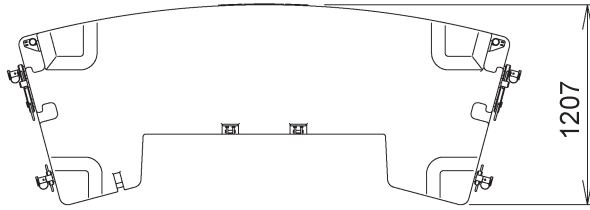

10 ton
Center weight

6 ton
Side weight

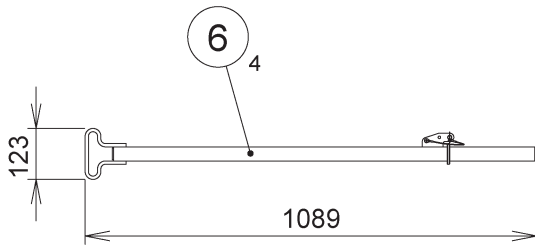

(Maximum width: 50)
Stanchion

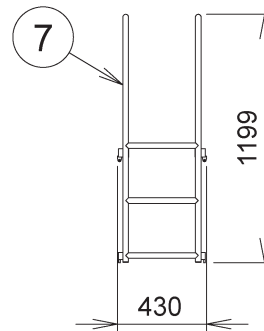

(Maximum width: 278)
Ladder

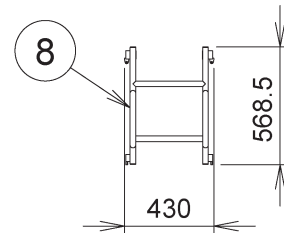

(Maximum width: 263)
Ladder

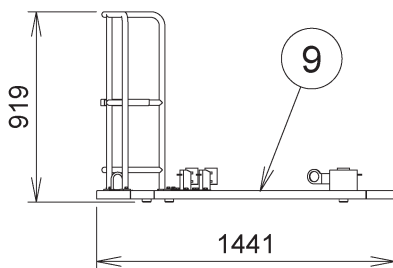
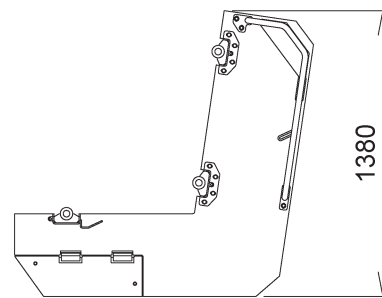
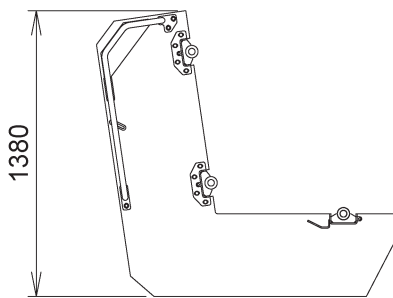

64 kg
Side step (right)

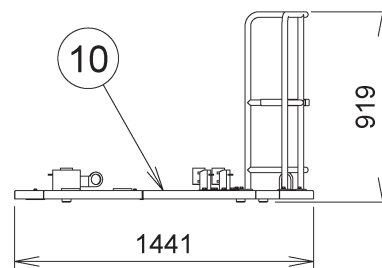

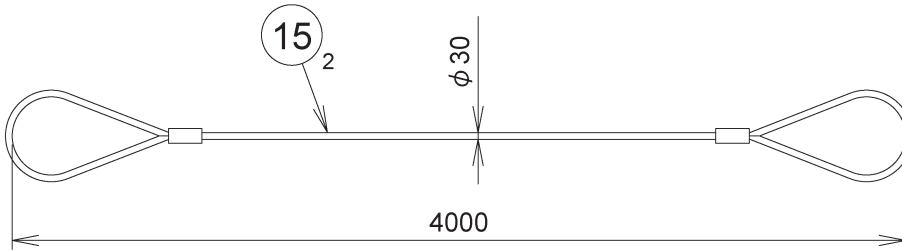
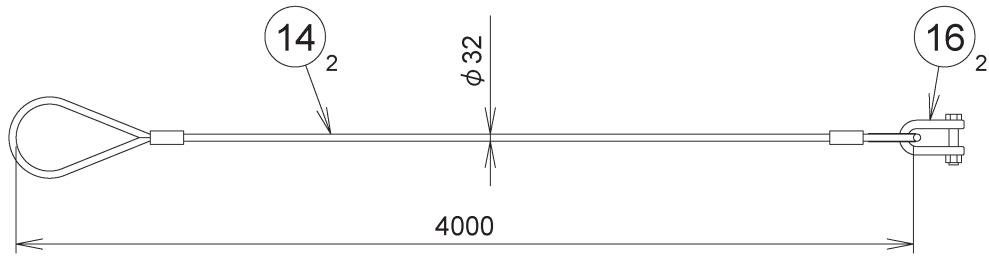

70 kg
Side step (left)

1702061-005-0E

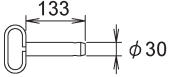

Lifting rope for counterweight

No.	Name	Q'ty	Note (Part No.)
1	Base weight	1	11 ton
2	Side base weight (right)	1	3 ton
3	Side base weight (left)	1	3 ton
4	Center weight	4	10 ton
5	Side weight	8	6 ton
6	Stanchion assembly	4	
7	Ladder	1	(741-35181002)
8	Ladder	1	(741-35182001)
9	Side step (right) assembly	1	
10	Side step (left) assembly	1	
11	Pin	2	 (741-35113000)
12	Quick pin	4	 (001-20525000)
13	Quick pin	8	 (001-20540000)
14	Wire rope	2	φ 32×4000 (641-35151001)
15	Wire rope	2	φ 30×4000 (741-35186000)
16	Shackle	2	For 16 ton (641-35152000)

4. Boom (951Q-0005-0E)

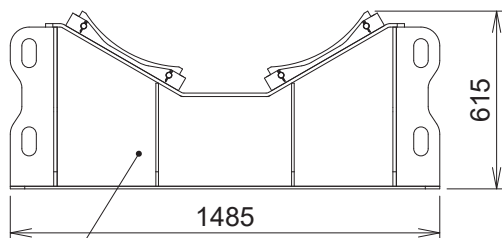
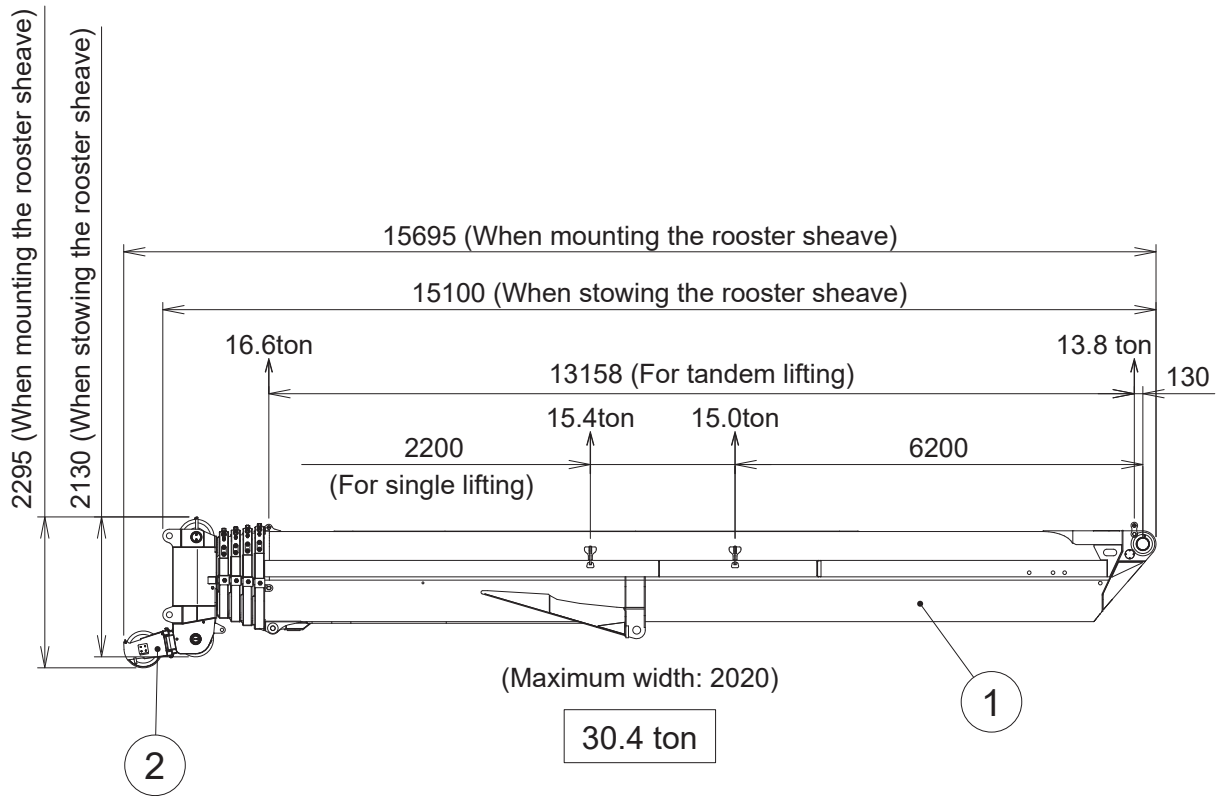

4 (Maximum width: 500)

240 kg

Boom transport stand

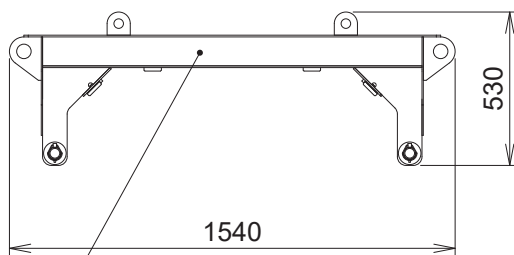

5 (Maximum width: 147)

50 kg

Fastening hanger for transporting the boom

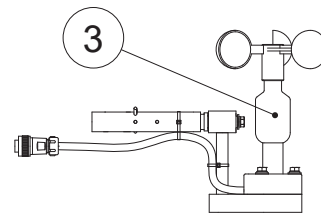

3
Anemometer

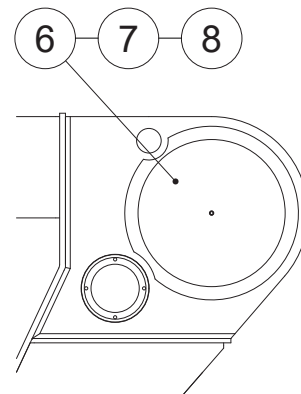

Boom foot cover
(used for transporting the boom)





I702121-003-0E

No.	Name	Q'ty	Note (Part No.)
1	Boom assembly	1	
2	Rooster sheave assembly	1	
3	Anemometer assembly	1	(Used for both the boom and the jib)
4	Stand	2	(For transporting the boom)
5	Hanger assembly	1	(For transporting the boom)
6	Cover	2	(741-49903000)
7	Cover	2	(741-49904000)
8	Wing nut	2	(001-13408000)

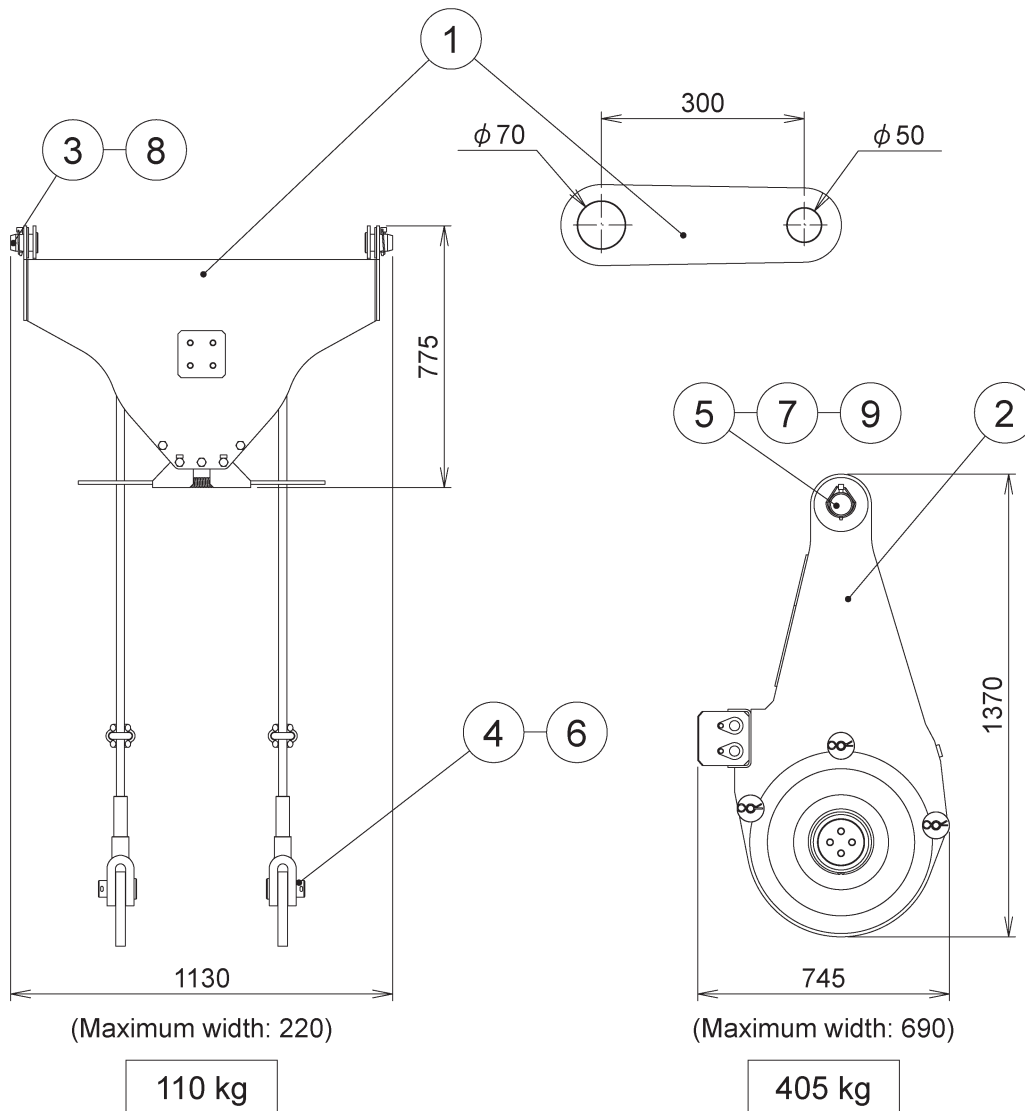
I702061-008-0E

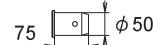
5. Boom heavy load lifting equipment (951Q-0006-0E)

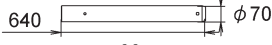
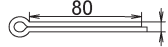
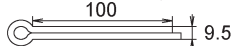

No.	Name	Q'ty	Note (Part No.)
1	Sub top sheave assembly	1	
2	Sheave block assembly	1	
3	Pin	2	 $\phi 50$
4	Pin	2	 $\phi 50$
5	Pin	1	 $\phi 70$ (951-48404000)
6	Split pin	2	 7.5 (001-20208080)
7	Split pin	1	 9.5 (001-20210100)
8	Quick pin	2	 $\phi 10$ (001-20550000)
9	Quick pin	1	 $\phi 12$ (001-20570000)

1702061-009-0E

6. SL jib (951Q-0007-0E)

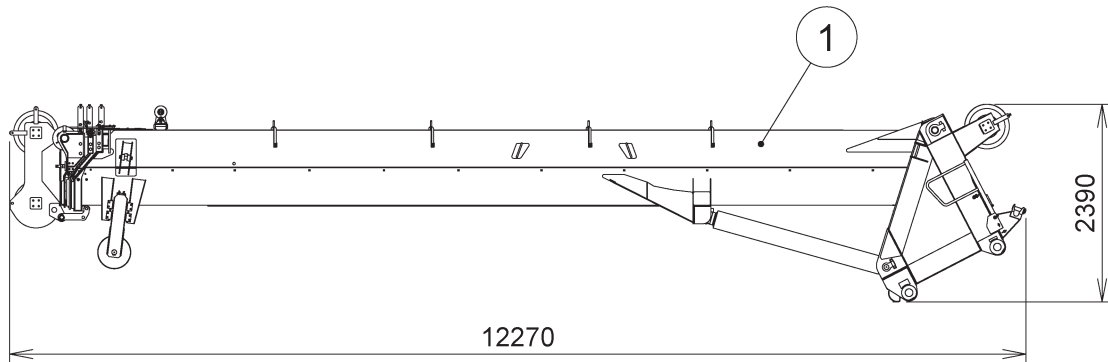

(Maximum width: 1460)

9.8 ton

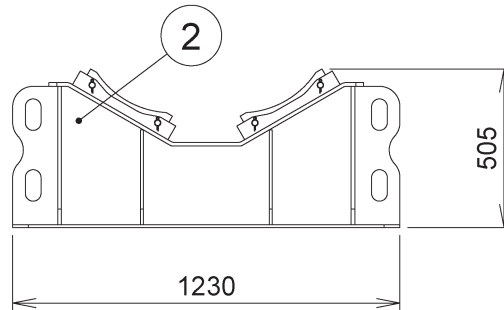

(Maximum width: 400)

180 kg

Super luffing jib transport stand

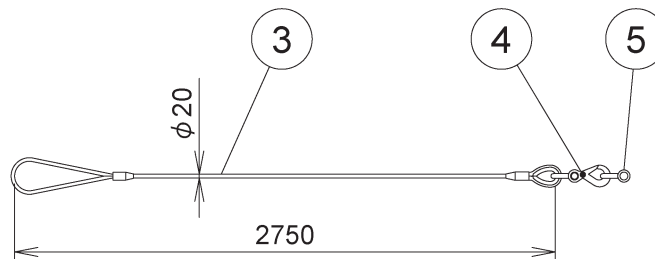

No.	Name	Q'ty	Note (Part No.)
1	Super luffing jib assembly	1	
2	Stand	1	
3	Wire rope	4	(741-47773000)
4	Hook	4	(741-47774000)
5	Shackle	8	(201-84103000)

7. Heavy lift jib (951Q-0008-0E)

Base bracket assembly

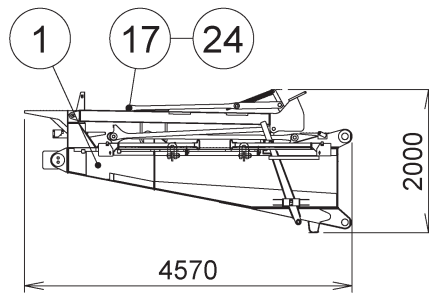

(Maximum width: 2095)

3.0 ton

Jib [1] assembly

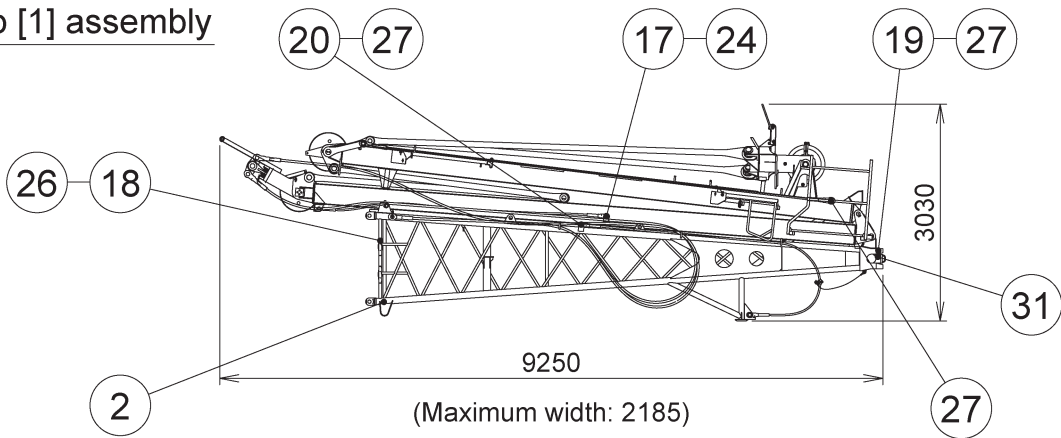

(Maximum width: 2185)

3.8 ton

Jib [2]

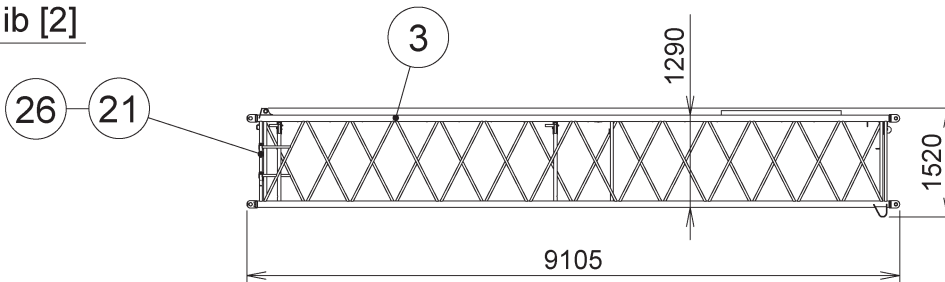

(Maximum width: 1580)

0.9 ton

Jib [3]

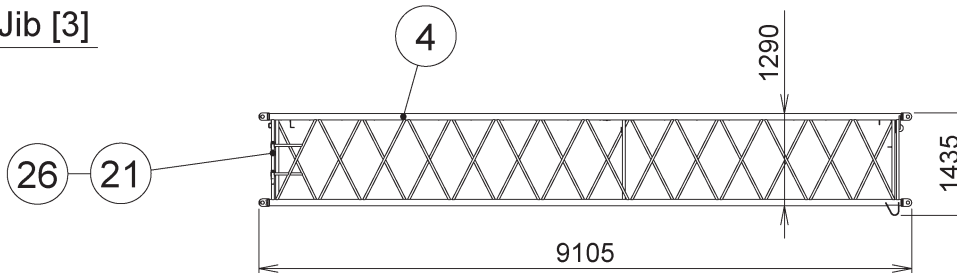

(Maximum width: 1595)

0.9 ton

2set

Jib [4]

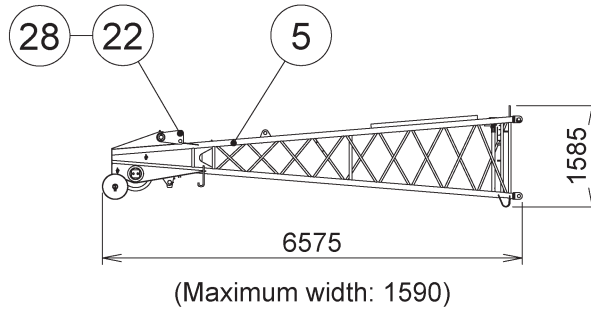

1.1 ton

Jib [5]

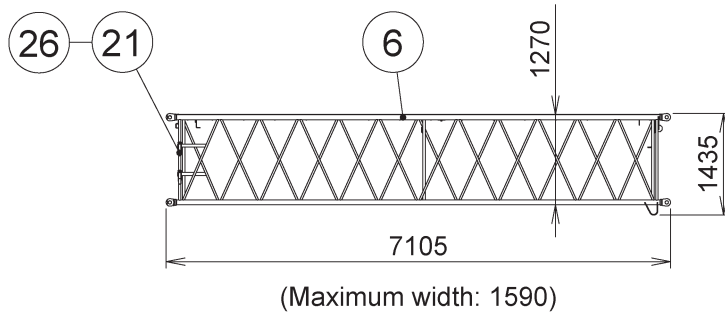

2set

0.6 ton

Jib [6]

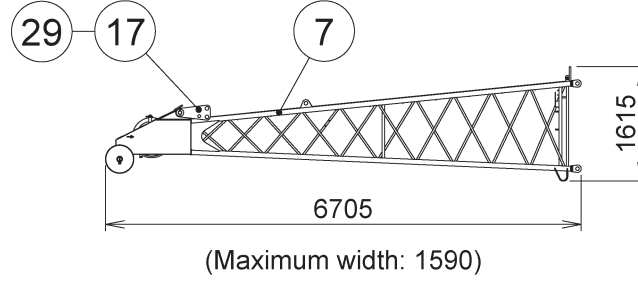

0.8 ton

Two-layer sheave case

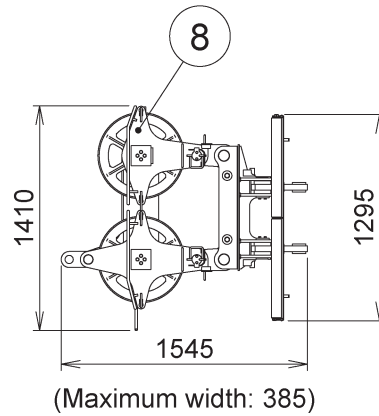

310 kg

Front pendant rope

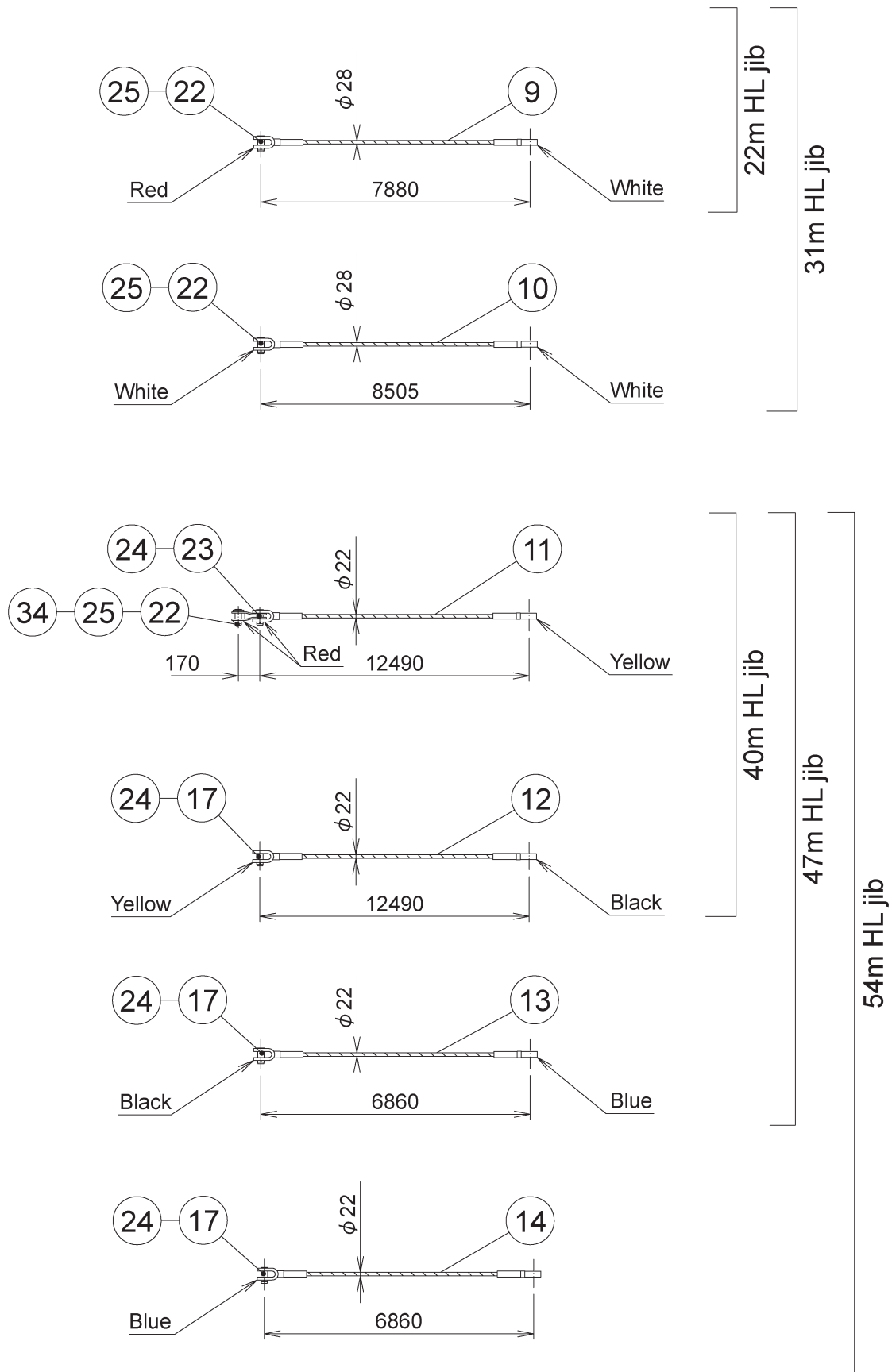

I702061-013-0E

Sub-pendant rope

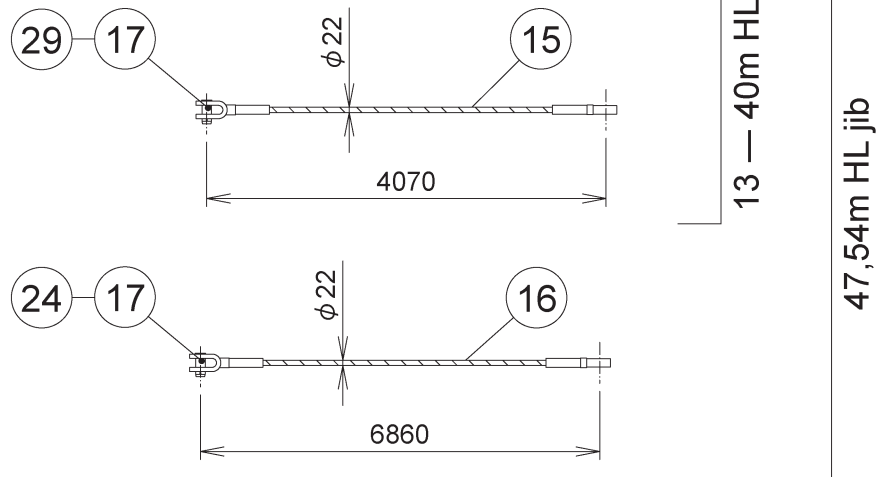

Roller block
(For jib mounting/dismounting)

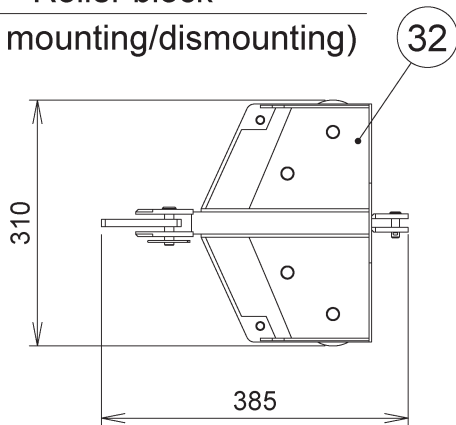

Remote control for operating the jib coupler
(Cord length: 3m)

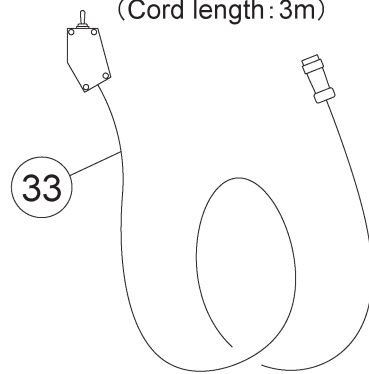

Sling wire rope
(common to the SL jib)

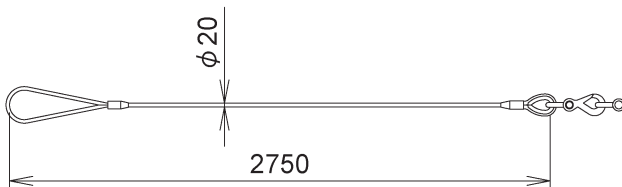

Optional device

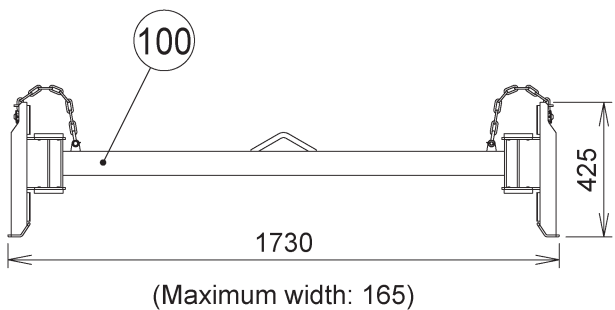



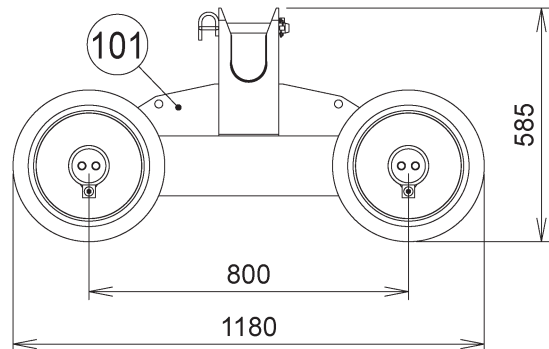



27 kg
Jib stand

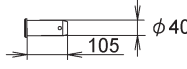
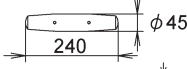
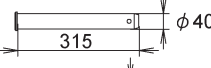
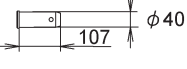

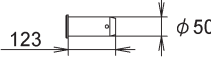
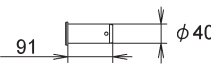
380 kg
Roller stand

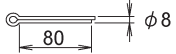
1702061-014-0E

No.	Name	Q'ty	Note (Part No.)
1	Base bracket assembly	1	
2	Jib [1] assembly	1	
3	Jib [2]	1	
4	Jib [3]	2	
5	Jib [4]	1	
6	Jib [5]	2	
7	Jib [6]	1	
8	Two-layer sheave case	1	
9	Front pendant rope	4	Stamped "BB" (941-42325000)
10	Front pendant rope	4	Stamped "BC" (951-42326000)
11	Front pendant rope	4	Stamped "BD" (951-42327000)
12	Front pendant rope	4	Stamped "BD" (951-42327000)
13	Front pendant rope	4	Stamped "E" (411-42349000)
14	Front pendant rope	4	Stamped "E" (411-42349000)
15	Sub-pendant rope	2	Stamped "BE" (951-42328000)
16	Sub-pendant rope	2	Stamped "E" (411-42349000)
17	Pin	24	 $\phi 40$ (741-42345000)
18	Pin	4	 $\phi 45$ (951-42330000)
19	Pin	2	 $\phi 40$ (411-42342000)
20	Pin	2	 $\phi 40$ (872-42116000)
21	Pin	20	 $\phi 45$ (951-42331000)
22	Pin	16	 $\phi 50$ (741-42344000)
23	Pin	4	 $\phi 40$ (872-42405000)
24	Split pin	22	 $\phi 8$ (001-20208060)
25	Split pin	12	 $\phi 8$ (001-20208080)

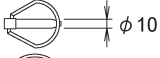
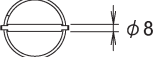
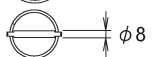
No.	Name	Q'ty	Note (Part No.)
26	Snap pin	28	 (132-47313000)
27	Quick pin	6	 $\phi 10$ (001-20540000)
28	Quick pin	4	 $\phi 8$ (641-41300A00)
29	Quick pin	6	 $\phi 8$ (641-42500B00)
31	Block	2	(741-42338000)
32	Roller block assembly	1	
33	Remote control	1	For operating the jib coupler
34	Link	4	
100	Jib stand	10	
101	Roller stand	1	

List of the number of used pins for each jib length

	Name	Jib length					
		13m	22m	31m	40m	47m	54m
17	Pin	-	-	-	8	12	16
18	Pin	2	4	4	4	4	4
21	Pin	2	4	8	12	16	20
22	Pin	4	8	12	4	4	4
23	Pin	-	-	-	4	4	4
24	Split pin	-	-	-	8	12	16
25	Split pin	-	4	8	4	4	4
26	Snap pin	6	12	16	20	24	28
28	Quick pin	4	4	4	-	-	-
29	Quick pin	-	-	-	4	4	4

Note 1. The pins 18 and 21 and snap pin 26 are to be used for connecting the jib.



(The jib couplers are not used for the connecting.)

2. The pins 17, 22 and 23, split pins 24 and 25 and quick pins 28 and 29 are to be used for the front pendant rope.

I702061-016-0E

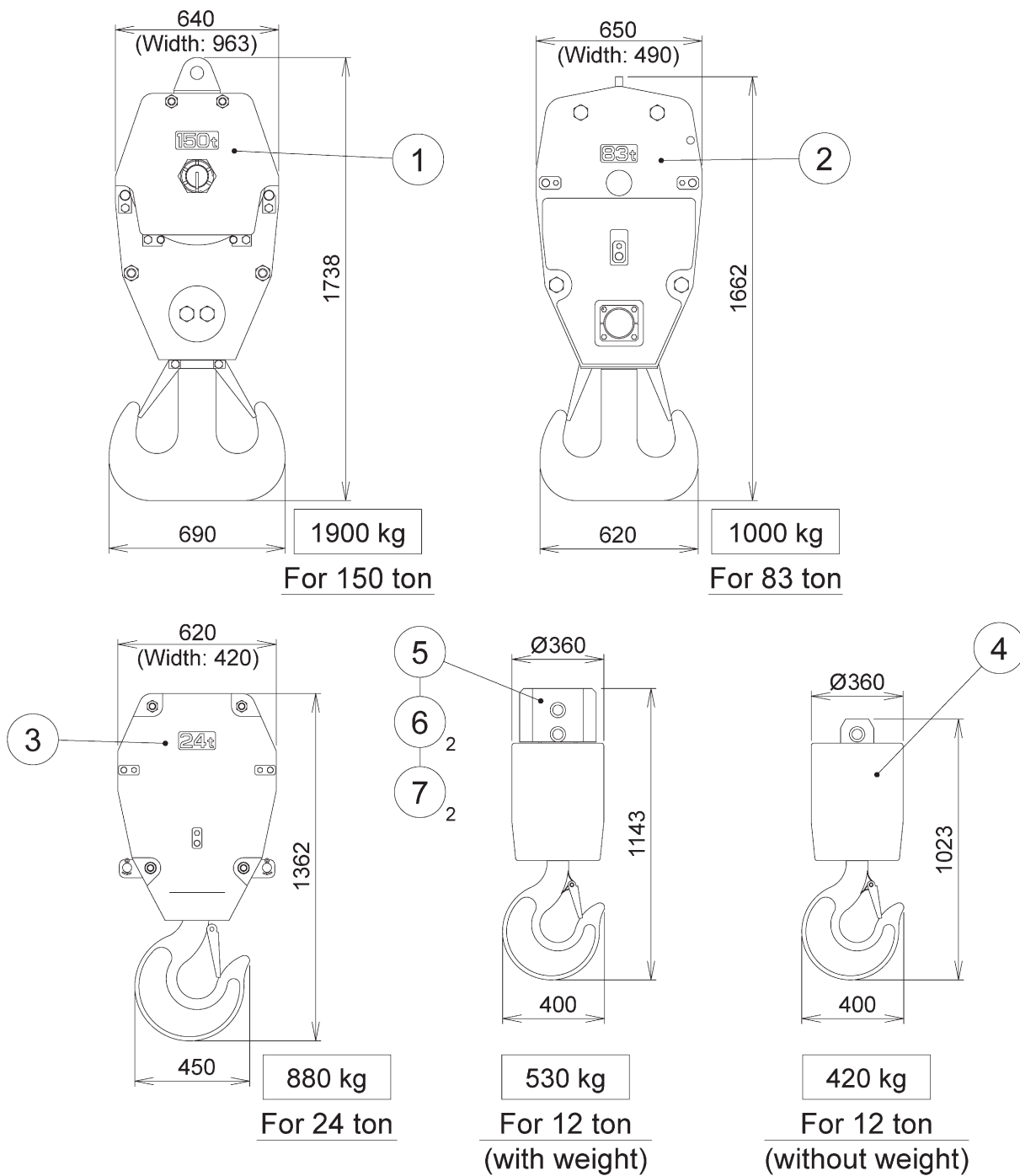
8. Hook (951Q-0009-0E)



No.	Name	Q'ty	Note (Part No.)
1	Hook assembly	2	For 150 ton
2	Hook assembly	1	For 83 ton
3	Hook assembly	1	For 24 ton
4	Hook assembly	1	For 12 ton
5	Sub weight	1	
6	Pin	2	 (872-83106002)
7	Split pin	2	 (001-20208080)

I702061-017-1E

9. Overhoisting detector (951Q-0010-0E)

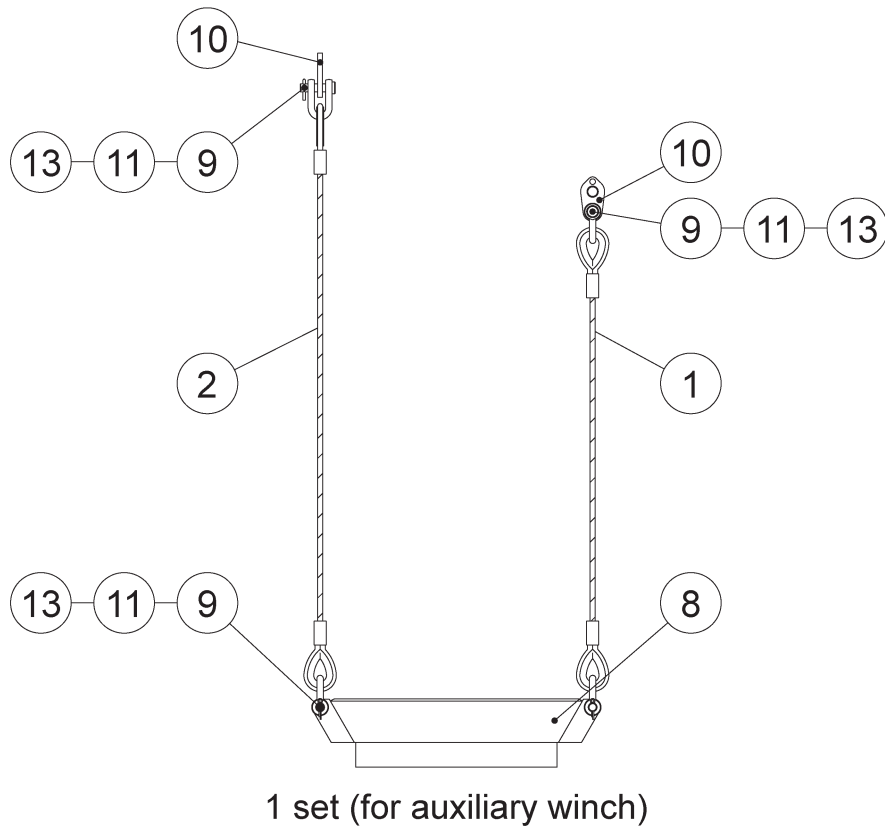
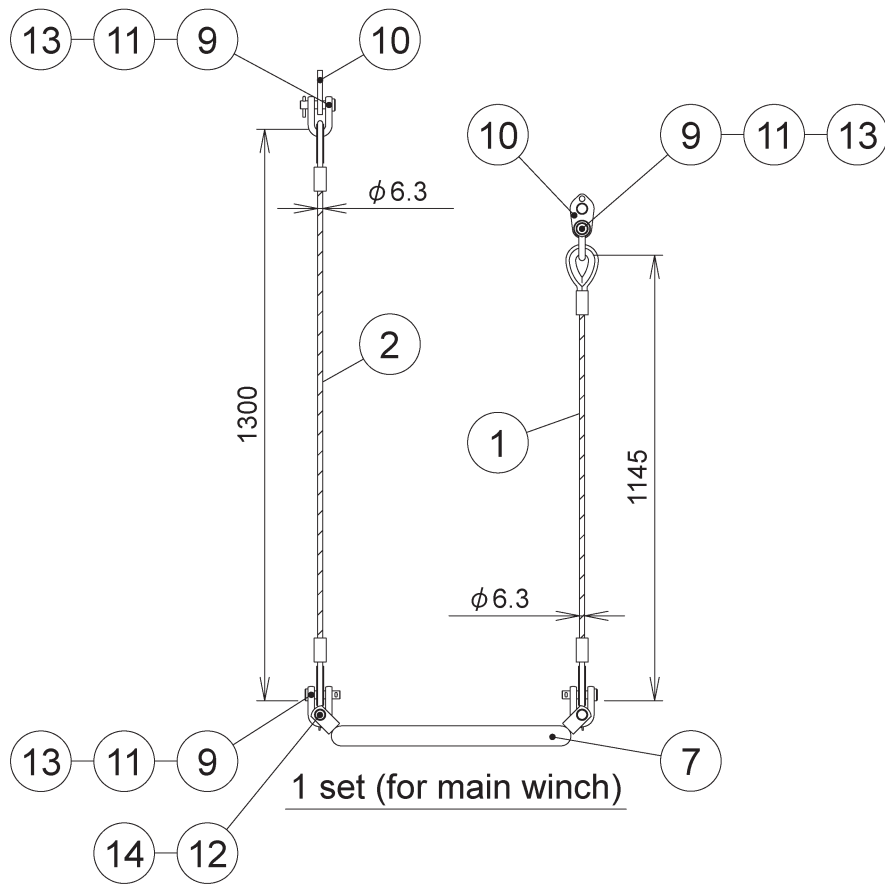

1702061-018-0E

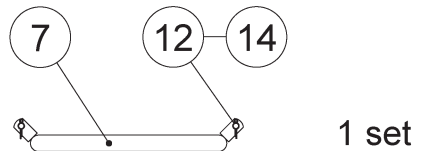
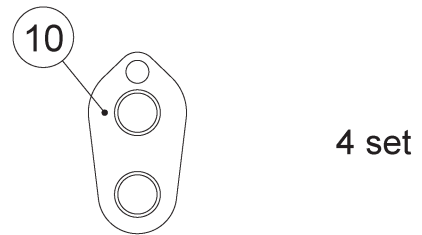
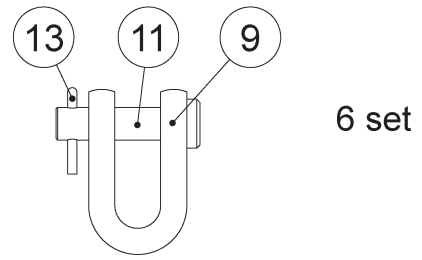
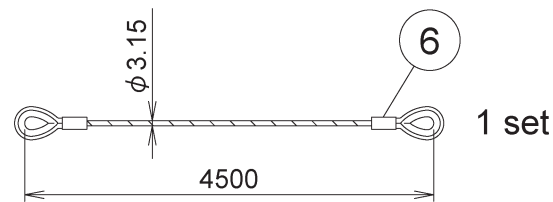
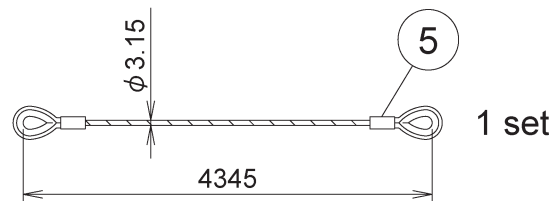
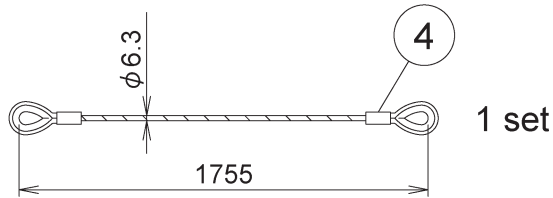
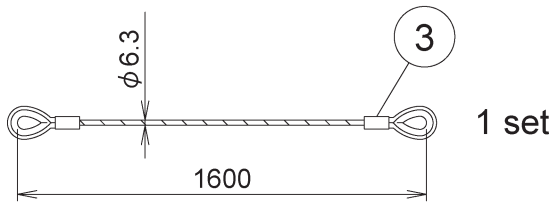

No.	Name	Q'ty	Note (Part No.)
1	Wire rope	2	(741-82203000)
2	Wire rope	2	(962-82201000)
3	Wire rope	1	(203-82201000)
4	Wire rope	1	(203-82202000)
5	Wire rope	1	(741-82201000)
6	Wire rope	1	(741-82202000)
7	Weight	2	(832-82201000)
8	Weight	1	(832-82301000)
9	Shackle	14	(102-82202000)
10	Link	8	(881-82304000)
11	Pin	14	(102-82207000)
12	Pin	4	(001-20110030)
13	Split pin	14	(001-20203016)
14	Split pin	4	(001-20203020)

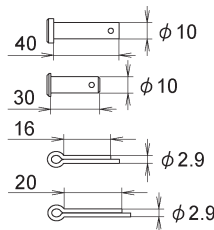

10. Tools (649Q-0007-0E)

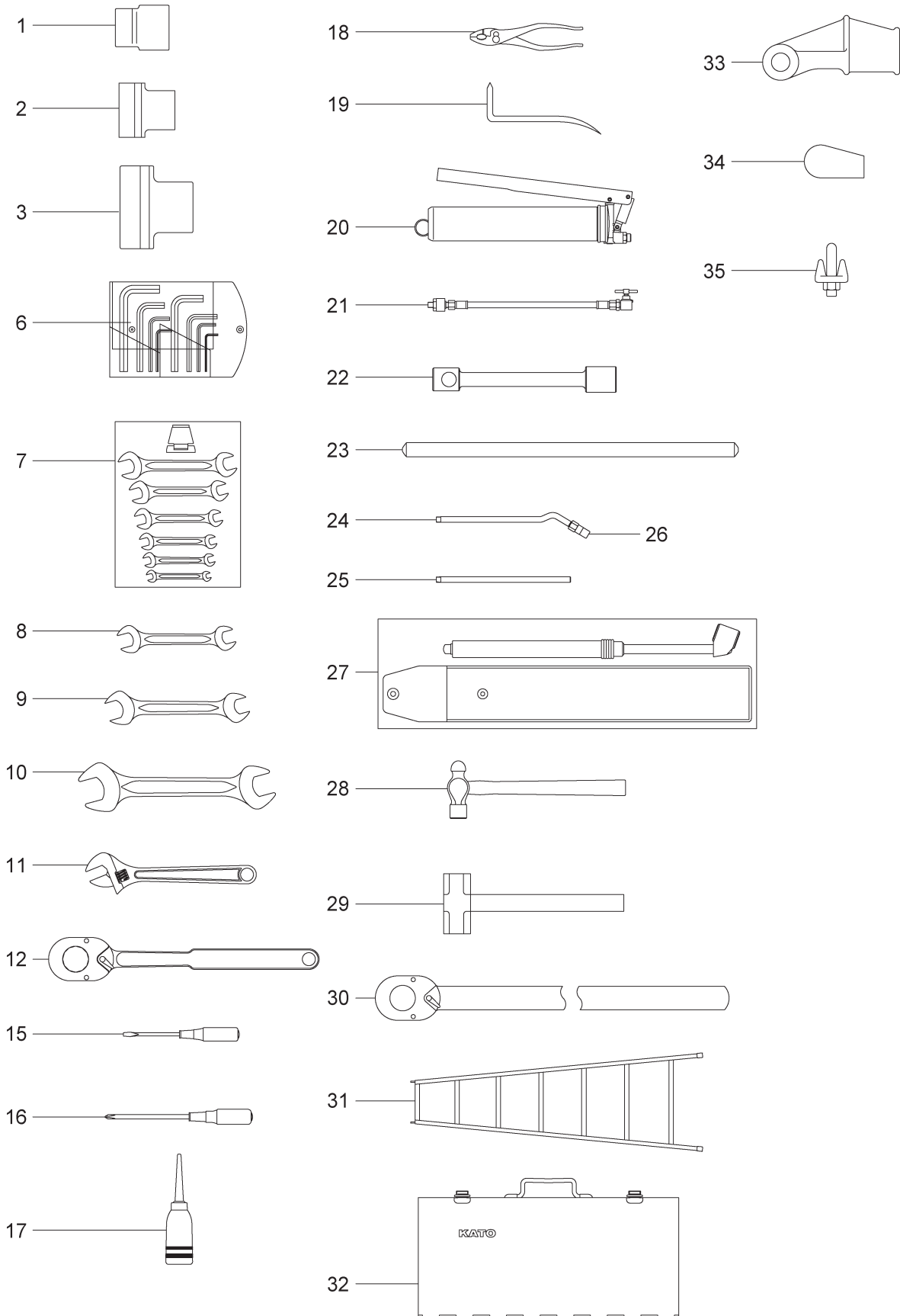

No.	Name	Q'ty	Note (Part No.)
1	Socket	1	17×3/4
2	Socket	1	30×3/4
3	Socket	1	50×3/4
6	Hexagon key set	1	
7	Spanner set	1	
8	Open-end spanner	1	27×30
9	Open-end spanner	1	36×41
10	Open-end spanner	1	46×50
11	Adjustable spanner	1	375
12	Ratchet wrench	1	3/4
15	Screwdriver, blade (-)	1	100
16	Screwdriver, Phillips (+)	1	150
17	Oil feeder	1	
18	Pliers	1	200
19	Split pin puller	1	Split pin extractor
20	Grease gun	1	
21	Nozzle hose	1	
22	Wheel nut socket	1	32
23	Handle	1	
24	Pipe	1	
25	Pipe	1	
26	Nozzle	1	
27	Tire gauge	1	
28	Hammer	1	1 pound
29	Hammer	1	4 pound
30	Torque wrench	1	(For bayonet fastening)
31	Stepladder	1	
32	Tool box	1	
33	Rope socket	2	
34	Rope wedge	2	
35	Wire clip	2	