

Data subject to change without prior notice
Edition 03/2020 © 2020 JMG Cranes S.p.A. All rights reserved
Rev.1 - 03/20



Electric Pick & Carry Cranes

JMG Cranes S.p.A.

Sales & Service Office
Via Bergamo, 142
26100 Cremona - Italy
t +39 0372 1786738
Production Plant
Via Sito Nuovo 14
29010 Sarmato (PC) - Italy
t +39 0523 8486
e info@jmgcranes.com



MC 580S (inch)
Max Capacity
127,800 lb

www.jmgcranes.com



MC 580

- FRONT-WHEELS DRIVE WITH COUNTER ROTATION
- HYDRAULICALLY TELESCOPING PROPORTIONAL TYPE BOOM
- 180° REAR STEERING
- REMOVABLE COUNTERWEIGHTS

Options :

- HYDRAULIC WINCH
- HYDRAULIC JIB WITH HYDRAULIC EXTENSION
- BENDABLE MANUAL JIB WITH MANUAL EXTENSION
- NON-MARKING TIRES
- FRONT OUTRIGGERS
- RADIO REMOTE CONTROL
- HYDRAULIC FORKS
- MAN BUCKET
- ATEX CONVERSIONS
- CUSTOMIZED PAINTING



Technical features

Max Capacity lbs	127,800
Dimensions inch	17'4"x7' 8"x8' 1"

Front-wheels drive. 2 electric motors AC 16 kW 96V AC, 135 A. Insulation class H	LMI Electronic safe load indicator and tilting moment limiter
Total lbs 86,000 Removable counterweights lbs 26,500	Hydraulically foot controlled service brake on all wheels, hydraulically automatic or button controlled parking brake on front wheels
96 V - 1550 Ah 8 working hours	Fabricated from preformed and welded quality steel plate
Front nr. 4 cushion 40x16-30" Rear nr. 4 superelastic 355/50-15"	+60°/-3°
Rear Steering angle -90°/+90°	Motor driven pump 1x45 kW - 96 V AC, 1x23 kW - 96 V AC.

Load charts

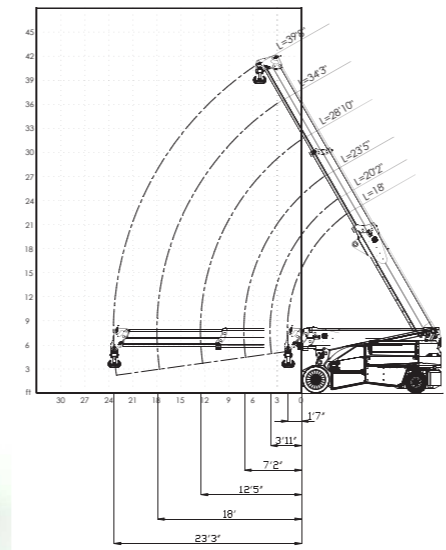

(lb)	18'	20'2"	23'5"	28'10"	34'3"	39'8"
0	127800	127800	121000	106000		
1'7"	127800	127800	121000	101000		
1'8"	127800	127800	121000	101000		
3'3"		102000	102000	93000	80000	
3'10"		91000	91000	90000	78000	
4'11"			76000	76000	73000	
6'6"			60000	60000	60000	57000
7'1"			58000	59000	60000	57000
8'2"				52000	52000	52000
9'10"				44000	44000	44000
11'5"					37000	38000
12'6"					34000	35000
13'1"						33000
14'9"						29000
16'4"						26000
17'10"						23000
18'						23000
19'8"						21000
21'3"						19000
22'11"						17000
23'3"						17000

(lb)	18'	20'2"	23'5"	28'10"	34'3"	39'8"
0	127800	127800	121000	106000		
1'7"	127800	127800	121000	101000		
1'8"	127800	127800	121000	101000		
3'3"		127800	119000	93000	80000	
3'10"		108000	108000	90000	78000	
4'11"			99000	86000	73000	
6'6"			78000	79000	68000	57000
7'1"			73000	74000	66000	57000
8'2"				65000	63000	55000
9'10"				55000	55000	51000
11'5"				47000	47000	47000
12'6"				43000	44000	44000
13'1"					42000	42000
14'9"					37000	37000
16'4"					33000	33000
17'10"					30000	30000
18'						30000
19'8"						28000
21'3"						24000
22'11"						23000
23'3"						22000

(lb)	18'	20'2"	23'5"	28'10"	34'3"	39'8"
0	127800	127800	121000	106000		
1'7"	127800	127800	121000	101000		
1'8"	127800	127800	121000	101000		
3'3"		127800	119000	93000	80000	
3'10"		110000	116000	90000	78000	
4'11"			112000	86000	73000	
6'6"			106000	80000	68000	57000
7'1"			93000	78000	66000	57000
8'2"				75000	63000	55000
9'10"				70000	58000	51000
11'5"				66000	54000	47000
12'6"				64000	52000	45000
13'1"					50000	44000
14'9"					47000	41000
16'4"					45000	38000
17'10"					43000	36000
18'						36000
19'8"						34000
21'3"						32000
22'11"						30000
23'3"						30000

EU Standards CE

	Classification UNI ISO 4030-1: A3
	EU Standards CE 2006/42 CE MD-2014/30 CE EMC - 2014/35 CE LVD - 2000/14 and subsequent modifications
	Relevant regulations EN 13000:2014 UNI ISO 4301-2:2011 and subsequent modifications

Dimensions

