

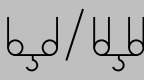







CARGAS / LOADS

J168HPA

 SR/DR (lb)		Cargas máximas / <i>Maximum loads</i> Single Reeving / Double Reeving - 6600/13200 lb					
 [ft]	6600/13200 lb @ ... (ft)	Alcance del gancho [ft] / <i>Hook reach [ft]</i>					
		82	98	115	131	148	164
164	156/94	6600/13200	6600/12500	6600/10400	6600/8700	6600/7300	5500
148	148/103	6600/13200	6600/13200	6600/11700	6600/9900	6600/7700	—
131	131/112	6600/13200	6600/13200	6600/12800	6600/10100	—	—
115	115	6600/13200	6600/13200	6600/13200	—	—	—
98	98	6600/13200	6600/13200	—	—	—	—

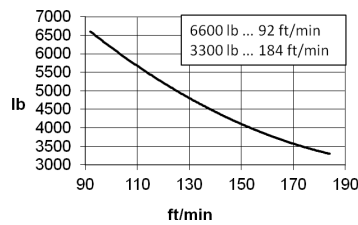
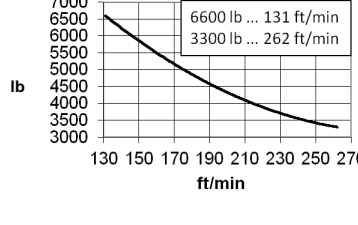
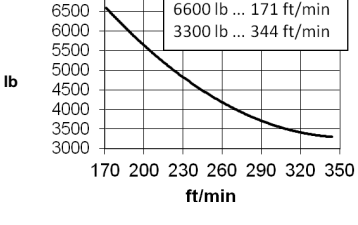
CARACTERISTICAS DE MECANISMOS / MECHANISMS

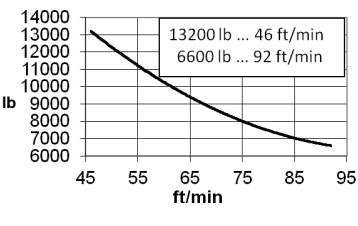
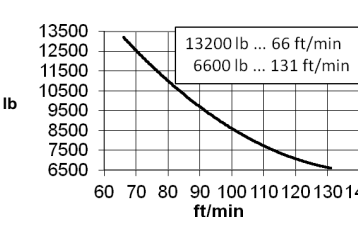
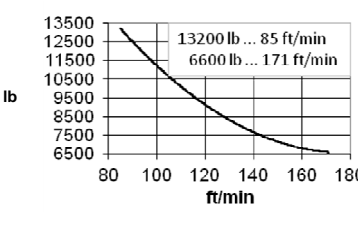
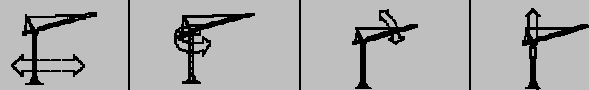
J168HPA

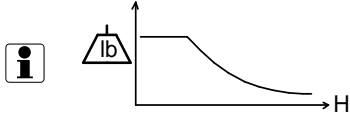
*opcional *optional					
	EC2556VF 18,4 kW	*EC3380VF 24,2 kW	EC40105VF 29,4 kW		
 lb ft/min					
 ilb ft/mn					
	TG2020VF 2x7,3 kW	OG1108VF 2x4 kW	EPH2020VF 15 kW	TH1506 11 kW	 480V 60Hz
					EC2556VF: AMPERAGE = 73 A EC3380VF: AMPERAGE = 84 A
0...66 ft/min	0... 0,8 r/min sl/min	2 min	2 ft/min	 H ≤	
				SR 1500 ft DR 741 ft	





Fecha / Date: 10/06/2019

Reservado el derecho a modificaciones sin previo aviso. Declinamos toda responsabilidad derivada de la información proporcionada
 Subject to modification, without previous warning. This information is supplied without liability

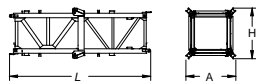
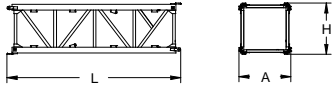
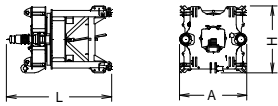
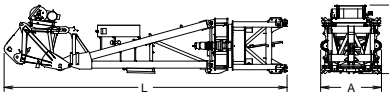
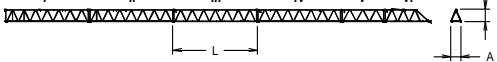
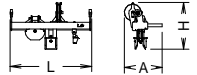
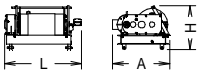
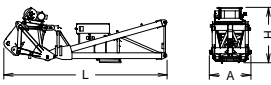
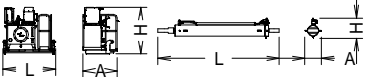
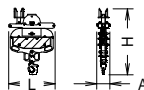
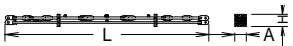
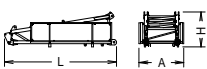
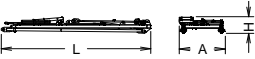

FEM 1005 - C25

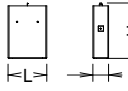
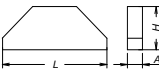
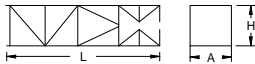
DENOMINACIÓN / DENOMINATION		L [ft]	A [ft]	H [ft]	P/W [lb]	
Torre inferior <i>Lower Tower</i>	TI-6-150		20.3	7.2	7.2	7790
Torre <i>Tower</i>	T6-150		20.3	6.1	6.1	6080
	TD6-150		20.3	6.1	6.1	6460
	TT6-150		20.3	6.1	6.1	6080
	T3-150		10.7	6.1	6.1	3420
	T12-150		39.4	6.1	6.1	11420
Torre asiento pista + base punta de torre + orientación <i>Slewing table + tower head base + slewing mechanism</i>			10.7	6.9	6.7	12130
Conjunto asiento pista, punta de torre, orientación y elevación <i>Slewing table assembly, tower head, slewing and hoisting mechanism</i>			31.9	6.9	8.2	26680
Tramo de pluma <i>Jib section</i>	[I]		33.7	4.4	4.9	2790
	[II]		33.4	4.0	4.9	2140
	[III]		33.3	4.0	4.8	1840
	[IV]		33.3	3.9	4.8	1640
	[V]		17.3	3.9	4.8	820
	[VI]		18.5	4.0	5.2	960
Punta de pluma <i>Jib end</i>			3.9	1.8	2.2	250
Mecanismo elevación carga <i>Hoisting mechanism</i>			4.7	3.5	2.6	1790
Punta de torre + Elevación carga <i>Tower head + hoisting mechanism</i>			23.6	6.1	8.2	14600
Elevación pluma con plataforma <i>Luffing mech + platform</i>			5.6	3.6	4.8	1630
			12.7	1.7	2.1	3860
Polipasto <i>Hook assembly</i>			2.7	0.8	3.9	490
Tirante sostén pluma <i>Jib support tie</i>			20.7	1.2	1.2	2650
Contrapluma con plataformas + Soporte contrapeso <i>/ Counterjib with platforms + Counterweight support</i>			17.3	6.9	5.2	5420
Parte superior <i>Top part</i>			18.9	5.8	2.2	1700
Plataforma y cabina <i>Platform and cabin</i>			13.6	6.9	8.2	2650
Contrapeso <i>Counterweight</i>			4.9	2.0	7.0	9040
			4.9	2.0	5.8	7720
			4.9	2.0	3.0	3640
Lastre <i>Ballast</i>			12.5	1.9	5.0	13220
Estructura torre de montaje <i>Jacking cage structure</i>	TM6-150PA		33.9	8.0	7.6	7720



Fecha / Date: 10/06/2019

Reservado el derecho a modificaciones sin previo aviso. Declinamos toda responsabilidad derivada de la información proporcionada
Subject to modification, without previous warning. This information is supplied without liability



FEM 1005 - C25

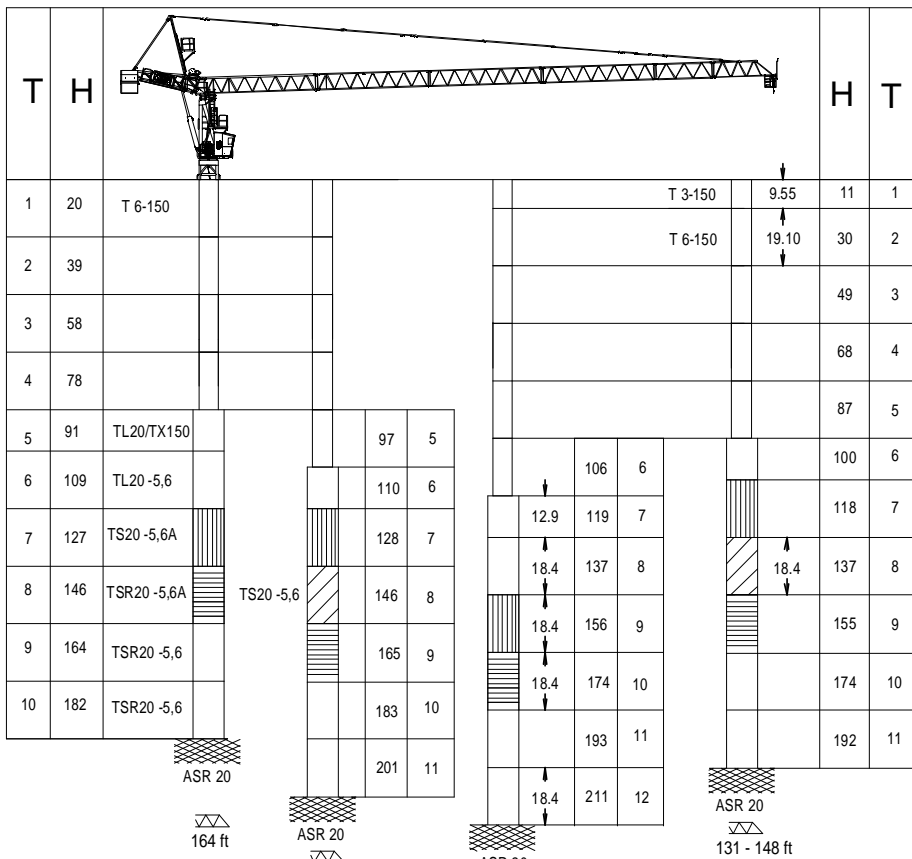

Transporte / Transport

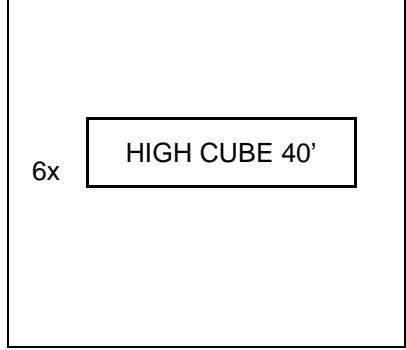
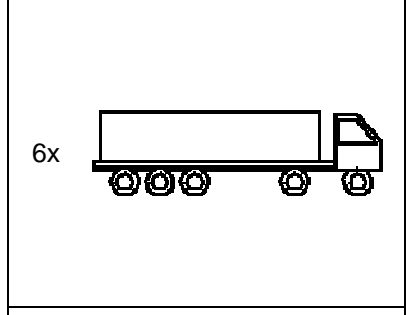
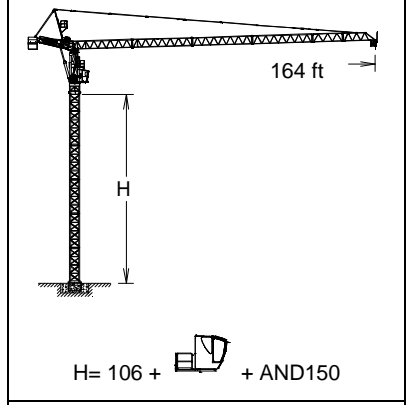

ASR 20:	160.21.200		
T3-150:	161.32.000	TS20-5,6A:	204.31.500
T6-150:	161.31.000	TS20-5,6:	204.31.200
TL20/TX50:	161.36.000	TSR20-5,6A:	204.31.300
TL20-5,6:	204.31.400	TSR20-5,6:	204.31.000

T: Torre / Tower
H: Altura / Height



Otras configuraciones de torre / Other tower configuration

TREPADO / CLIMBING

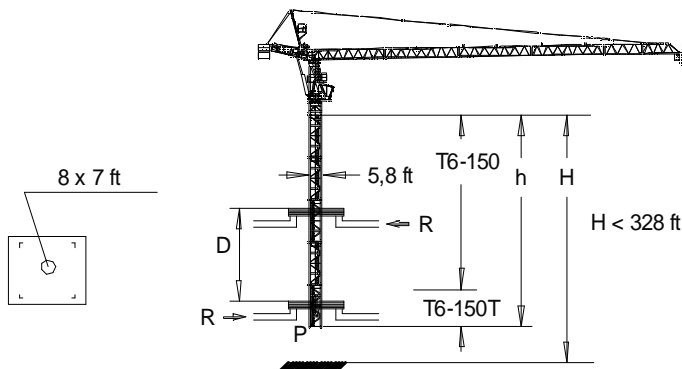

h_{max}: T6150T + 4xT6-150

	▶	■
h (m)	95.5	
D (m)	39 - 46	
P (KN)	174200	160700
R _{max} (KN)	33700	68100



Trepado interno / Internal climbing.

- Viento fuera de servicio / Out of service wind
- Consultar / Consult
- En servicio / In service
- Fuera de servicio / Out of service



Ctra./Rd. Madrid - Irún Km. 415 - 20.213 IDIAZABAL [Gipuzkoa] ESPAÑA / SPAIN
P.O. Box, 23 - 20.200 BEASAIN - E-mail: jaso@jaso.com
Tel. +34 943 - 18 70 00 • Fax. +34 943 - 18 70 20
www.jaso.com

Fecha / Date: 10/06/2019

Reservado el derecho a modificaciones sin previo aviso. Declinamos toda responsabilidad derivada de la información proporcionada
Subject to modification, without previous warning. This information is supplied without liability

FEM 1005 - C25

DELEGACION / DEALER