

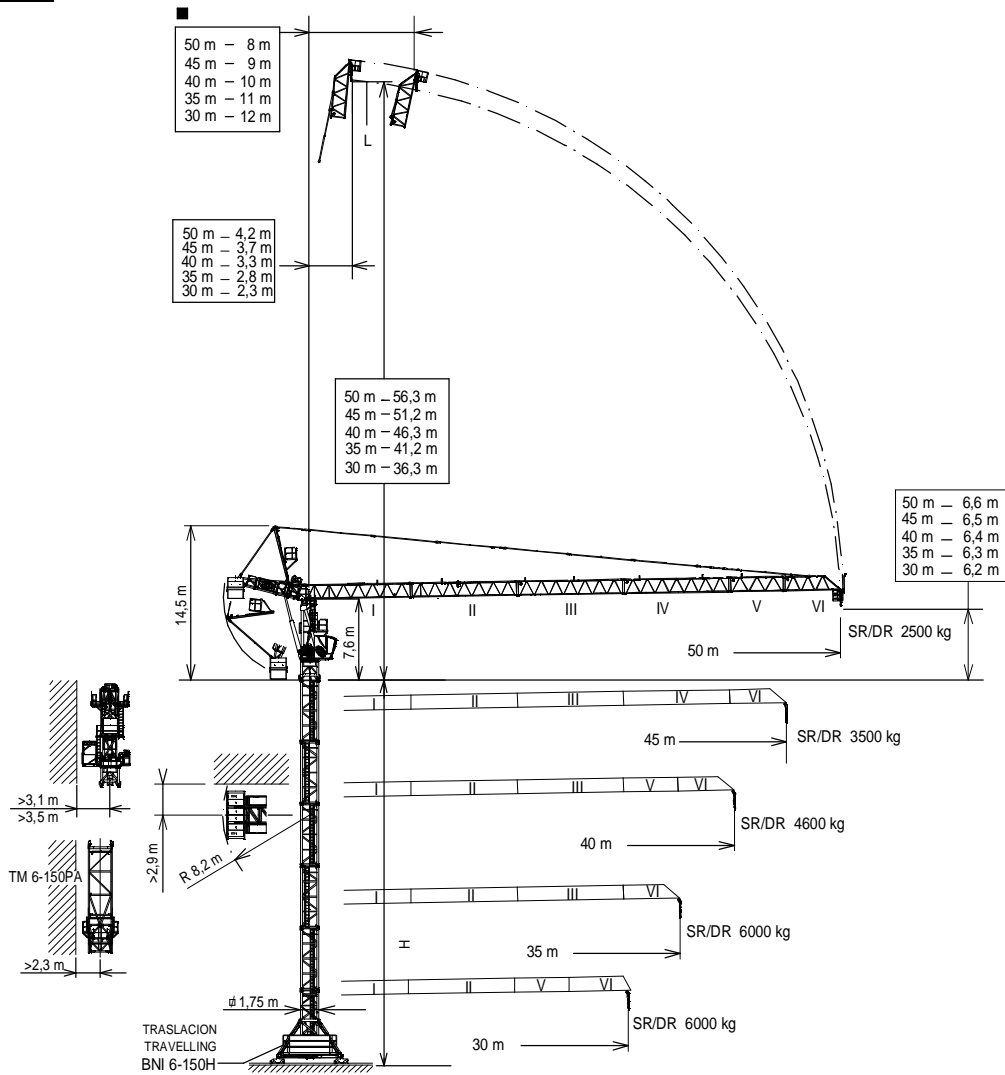

UNE 58-101
FEM 1001

UNE-EN-ISO 9001



Máxima altura de torre sin arriostrar (m).

Maximum tower height without fastening (m).

Hauteur maximale de tour sans ancrage (m).

H = Максимальная высота башни без крепления (m).

Desteksiz maksimum kule yüksekliği (m)

أقصى ارتفاع للبرج بدون ربط (م)

* Tramo pluma / Jib section / Tronçon de flèche / Секция стрелы / Bom bölümü / أجزاء الذراع

** Punta de pluma / Jib end / Pointe de flèche / Конец стрелы / Bom ucu / مقدمة الذراع

*Tramo pluma I / Jib section I ----- 208.40.000

*Tramo pluma II / Jib section II ----- 208.41.000

*Tramo pluma III / Jib section III --- 208.42.000

*Tramo pluma IV / Jib section IV--- 208.43.000

*Tramo pluma V / Jib section V --- 208.44.200

*Tramo pluma VI / Jib section VI--- 208.45.700

**Punta pluma/Jib end----- 208.45.000

TM 6-150PA -----161.35.500

T3-150-----161.32.000

T6-150-----161.31.000

TD6-150-----161.31.700

T12-150 ----- 161.31.500

AN 150 -----161.21.000

BNI 6-150 -----161.20.000

ABH 100-----201.23.000

(H) TRASLACIÓN / TRAVELLING /

TRASLACION / ПЕРЕМЕЩЕНИЕ / RAY YÜRÜYÜŞLÜ / متحركة

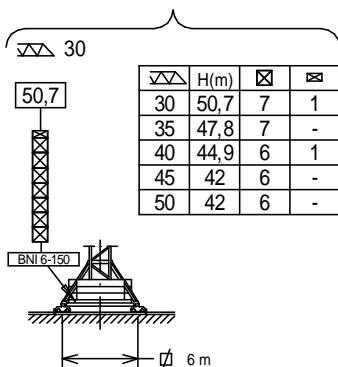

(H) ESTACIONARIA / STATIONARY /

STATIONAIRE / СТАЦИОНАРНОЕ СОСТОЯНИЕ / SABIT / ثابتة

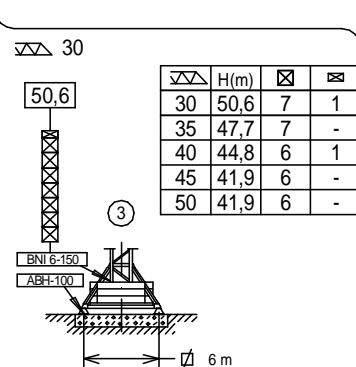
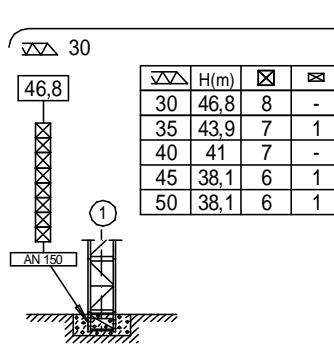

☒ T3-150

☒ T6-150

☒ TD6-150

☒ T12-150



Fecha / Date: 20/01/2016







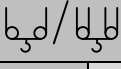



Reservado el derecho a modificaciones sin previo aviso. Declinamos toda responsabilidad derivada de la información proporcionada / Subject to modification, without previous warning. This information is supplied without liability / L'entreprise se réserve le droit de procéder à des modifications sans préavis. Nous déclinons toute responsabilité quant aux informations fournies / Мы оставляем за собой право на внесение изменений без предварительного уведомления. Мы снимаем с себя любую ответственность в отношении предоставленной информации / Önceden bildirilmeksizin değiştirilme hakkı saklıdır. Verilen bilgiler için hiçbir sorumluluk kabul etmemekteyiz

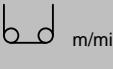
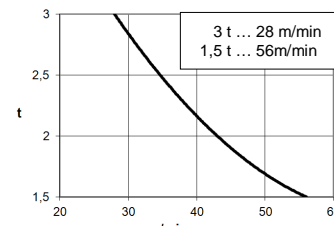
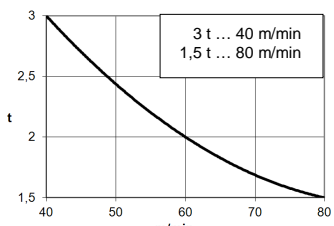
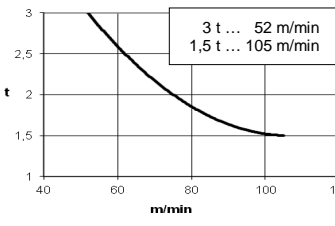

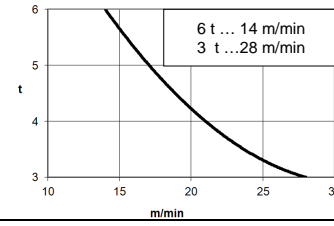
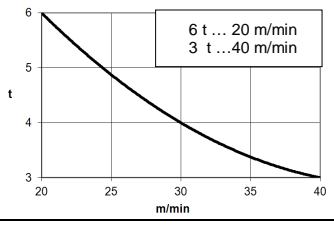
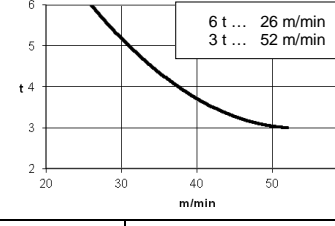
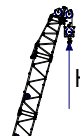
CARGAS / LOADS / CHARGES / НАГРУЗКИ / YÜKLER / الأحمال **J168HPA**

 SR/DR (kg)		Cargas máximas / Maximum loads / Charges maximales / Максимальные нагрузки / Maksimum yük / أقصى حمولة SR/DR - 3000/6000 kg					
 [m]	3000/6000 kg @ ... (m)	Alcance del gancho [m] / Hook reach [m] / Portée du crochet (m) / Радиус действия крюка (m) / Kancanın yüksekliği (m) / مدى الخطاف (m)					
		25	30	35	40	45	50
50 m	47,4/28,6	3000/6000	3000/5685	3000/4725	3000/3965	3000/3310	2500
45 m	45,0/31,5	3000/6000	3000/6000	3000/5310	3000/4470	3000/3500	—
40 m	40,0/34,1	3000/6000	3000/6000	3000/5815	3000/4600	—	—
35 m	35,0	3000/6000	3000/6000	3000/6000	—	—	—
30 m	30,0	3000/6000	3000/6000	—	—	—	—

CARACTERISTICAS DE MECANISMOS / MECHANISMS FEATURES / CARACTÉRISTIQUES DES MÉCANISMES / ХАРАКТЕРИСТИКИ МЕХАНИЗМОВ / MEKANİZMALARIN ÖZELLİKLERİ / الخصائص الآلية **J168HPA**

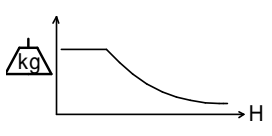
*opcional *optional *en option *опция *opsiyonel *اختياري							
		EC2556VF 18,4 kW	*EC3380VF 24,2 kW	EC40105VF 29,4 kW			
 t m/min							
	 t m/min						
						 H	$H \leq$ SR 452 m DR 226 m
				 400V 50Hz			
TG2020VF 2x7,3 kW	OG1108VF 2x4 kW	EPH2020VF 15 kW	TH1506 11 kW	P_{TOTAL}(EC2556VF + OG1108VF + EPH2020VF) = 41,4 kW P_{TOTAL}(*EC3380VF + OG1108VF + EPH2020VF) = *47,2 kW			
0...20 m/min	0... 0,8 r/min sl/min	2 min	0,6 m/min	 			



Fecha / Date: 20/01/2016

Reservado el derecho a modificaciones sin previo aviso. Declinamos toda responsabilidad derivada de la información proporcionada / Subject to modification, without previous warning. This information is supplied without liability / L'entreprise se réserve le droit de procéder à des modifications sans préavis. Nous déclinons toute responsabilité quant aux informations fournies / Мы оставляем за собой право на внесение изменений без предварительного уведомления. Мы снимаем с себя любую ответственность в отношении предоставленной информации / Önceden bildirilmeksizin değiştirilme hakkı saklıdır. Verilen bilgiler için hiçbir sorumluluk kabul etmemekteyiz / حقوق التغيير محفوظة دون إشعار مسبق. دون أدنى مسؤولية عن المعلومات المقدمة

 **FEM 1001**

DENOMINACIÓN / DENOMINATION / DÉSIGNATION / НАЗВАНИЕ / AÇIKLAMA / اسم		L [m]	A [m]	H [m]	P / W [kg]		
Torre inferior / Lower tower / Tour inférieure / Нижняя башня Alt kule / البرج السفلي	TI-6-150			6,175	2,190	2,190	3.535
Torre / Tower / Tour	T6-150 TD6-150 TT6-150 T3-150 T12-150			6,175 6,175 6,175 3,265 12,000	1,870 1,870 1,870 1,870 1,870	1,870 1,870 1,870 1,870 1,870	2.760 2.930 2.760 1.550 5.180
Torre asiento pista + base punta de torre + orientación Slewing table + tower head base + slewing mechanism Tour pivot + base du porte-flèche + mécanisme d'orientation Сиденье площадки + основание верхней секции башни + поворотный механизм Göbek +kule kafa bölümü tabanı+mekanizma / برج وحدة الدوارن + قاعدة رأس البرج + آلية الدوران				3,265	2,100	2,040	5500
Conjunto asiento pista, punta de torre, orientación y elevación Slewing table assembly, tower head, slewing and hoisting mechanism Groupe pivot + porte-flèche + mécanisme d'orientation + de levage Сиденье площадки + верхняя секция башни + поворотный механизм + подъемный механизм Göbek +kulenin kafa bölümü+mekanizma+vinç kulesi مجموعة وحدة الدوارن + رأس البرج + آلية الدوران + آلية الرفع				9,710	2,100	2,510	12100
Tramo de pluma Jib section Tronçon de flèche Секция стрелы Вот bölümü أجزاء الذراع	[I] [II] [III] [IV] [V] [VI]			10,265 10,165 10,160 10,160 5,270 5,636	1,355 1,215 1,215 1,205 1,205 1,230	1,485 1,485 1,465 1,465 1,465 1,580	1265 970 836 745 370 435
Punta de pluma / Jib end / Pointe de flèche / Конец стрелы / Вот усу / مقدمة الذراع				1,185	0,550	0,685	112
Mecanismo elevación carga / Hoisting mechanism / mécanisme de levage / подъемный механизм / Vinç kulesi / آلية الرفع				1,430	1,060	0,800	810
Punta de torre + Elevación carga / Tower head + hoisting mechanism Porte-flèche + mécanisme de levage / Верхняя секция башни + подъемный механизм Kulenin kafa bölümü + Vinç kulesi / رأس البرج + آلية الرفع				7,200	1,850	2,485	6600
Elevación pluma con plataforma / Luffing mech + platform / Relevage de flèche + plateforme / Подъем стрелы + Платформа + Yük kaldırma ve indirme + Platform / رافع الذراع + كابينة Clindro hidráulico / Hydraulic cylinder / Cylindre hydraulique /				1,685	1,100	1,465	740
Polipasto / Hook assembly / Palan / Полуспаст / Kanca takımı / بكرة / Gancho / Hook				0,835	0,235	1,175	220
Tirante sostén pluma / Jib support tie / Tirant de fleche / Растяжка поддержки стрелы / Kol destek bağları / مشد دعامة الذراع				6,305	0,360	0,370	1200
Contrapluma con plataformas + Soporte contrapeso / Counterjib with platforms + Counterweight support Contre-flèche avec plateformes / Противовесная консоль с платформами / Platformlu kuçruk / الذراع المقابل مع المنصة				5,260	2,100	1,580	2460
Parte superior Top part				5,740	1,760	0,680	770
Plataforma y cabina / Platform and cabin / Plateforme et cabine Платформа и кабина / Platform ve kabin / منصة وكابينة				3,500	2,070	2,425	1100
Contrapeso / Counterweight / Contrepoids / Противовес / Denge ağırlığı / اوزان معاكسة				1,486 1,486 1,486	0,600 0,600 0,600	2,125 1,750 0,905	4100 3500 1650
Lastre / Ballast / Lest / Балласт / Alt ağırlık taşları / ثقل				3,800	0,580	1,500	6000
Estructura torre de montaje / Jacking cage structure / Structure de tour de montage / Структура монтажной башни / Kaldırma kafesi yapısı / هيكل برج التركيب	TM6-150			10,320	2,420	2,310	3.500



Fecha / Date: 20/01/2016

Reservado el derecho a modificaciones sin previo aviso. Declinamos toda responsabilidad derivada de la información proporcionada / Subject to modification, without previous warning. This information is supplied without liability / L'entreprise se réserve le droit de procéder à des modifications sans préavis. Nous déclinons toute responsabilité quant aux informations fournies / Мы оставляем за собой право на внесение изменений без предварительного уведомления. Мы снимаем с себя любую ответственность в отношении предоставленной информации / Önceden bildirilmeksizin değiştirilme hakkı saklıdır. Verilen bilgiler için hiçbir sorumluluk kabul etmemekteyiz / حقوق التغيير محفوظة دون إشعار مسبق. دون أدنى مسؤولية عن المعلومات المقدمة



T	H	Component	Height (m)	T	H
1	6,2	T 6-150	3,3	1	3,3
2	12	T 6-150	9,1	2	9,1
3	17,8		149	3	149
4	23,7		20,7	4	20,7
5	29,5		26,5	5	26,5
6	35,3		30,5	6	30,5
7	39,2	TL20/TX150	32,4	6	32,4
8	44,8	TL20-5,6	38,3	7	38,3
9	50,4	TS20-5,6A	42,1	8	42,1
10	56	TSR20-5,6A	47,7	9	47,7
11	61,6		53,3	10	53,3
12	67,2	TSR20-5,6	58,9	11	58,9
			64,5	12	64,5
			70,1	13	70,1

ASR 20: 160.21.200 ASR 20
 T3-150: 161.32.000 ASR 20
 T6-150: 161.31.000 ASR 20
 TL20/TX50: 161.36.000 ASR 20
 TL20-5,6: 204.31.400 ASR 20
 TS20-5,6A: 204.31.500 ASR 20
 TS20-5,6: 204.31.200 ASR 20
 TSR20-5,6A: 204.31.300 ASR 20
 TSR20-5,6: 204.31.000 ASR 20

Otras configuraciones de torre / Other tower configuration / Autres configurations / Прочие конфигурации / Diğer konfigürasyonlar / مكونات أخرى

Transporte / Transport / Transport / Транспортировка / Taşıma / نقل

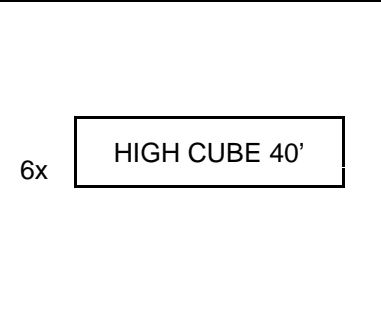
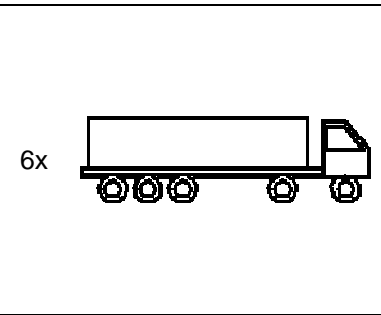
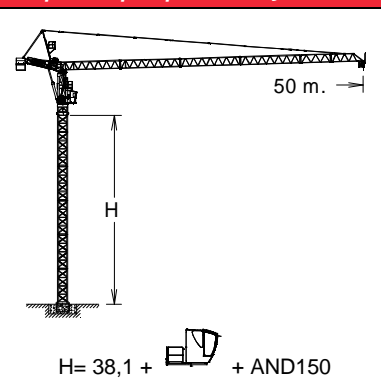

TREPADO / CLIMBING / TÉLESCOPAGE / ЛЕСТНИЦА / TIRMANMA / التسلق J168HPA

h_{max}: T6150T + 4xT6-150

h (m)	35
D (m)	13 - 16
P (KN)	800 740
Rmax (KN)	151 330

T6-150T: 161.32.500

Trepado interno / Internal climbing. / Télescopage intérieur / Внутренняя лестница / Bina içi tırmanma / التسلق الداخلي

- Wiento fuera de servicio / Out of service wind / Vitesse du vent hors service / Ветровая нагрузка в покое / Rüzgar devre dışı / الريح خارج الخدمة
- Consultar / Consult / Nous consulter / Консультируйтесь / Danışınız / الرجوع إلى
- En servicio / In service / En service / В работе / Devrede / في الخدمة
- Fuera de servicio / Out of service / Hors service / В покое / Devre dışı / خارج الخدمة



Ctra./Rd. Madrid - Irún Km. 415 - 20.213 IDIAZABAL [Gipuzkoa] ESPAÑA / SPAIN
 P.O. Box, 23 - 20.200 BEASAIN - E-mail: jaso@jaso.com
 Tel. +34 943 - 18 70 00 • Fax. +34 943 - 18 70 20
www.jaso.com

Fecha / Date: 20/01/2016

FEM 1001

DELEGACION / DEALER

Reservado el derecho a modificaciones sin previo aviso. Declinamos toda responsabilidad derivada de la información proporcionada / Subject to modification, without previous warning. This information is supplied without liability / L'entreprise se réserve le droit de procéder à des modifications sans préavis. Nous déclinons toute responsabilité quant aux informations fournies / Мы оставляем за собой право на внесение изменений без предварительного уведомления. Мы снимаем с себя любую ответственность в отношении предоставленной информации / Önceden bildirilmeksizin değiştirilme hakkı saklıdır. Verilen bilgiler için hiçbir sorumluluk kabul etmemekteyiz /

حقوق التغيير محفوظة دون إشعار مسبق. دون أدنى مسؤولية عن المعلومات المقدمة