

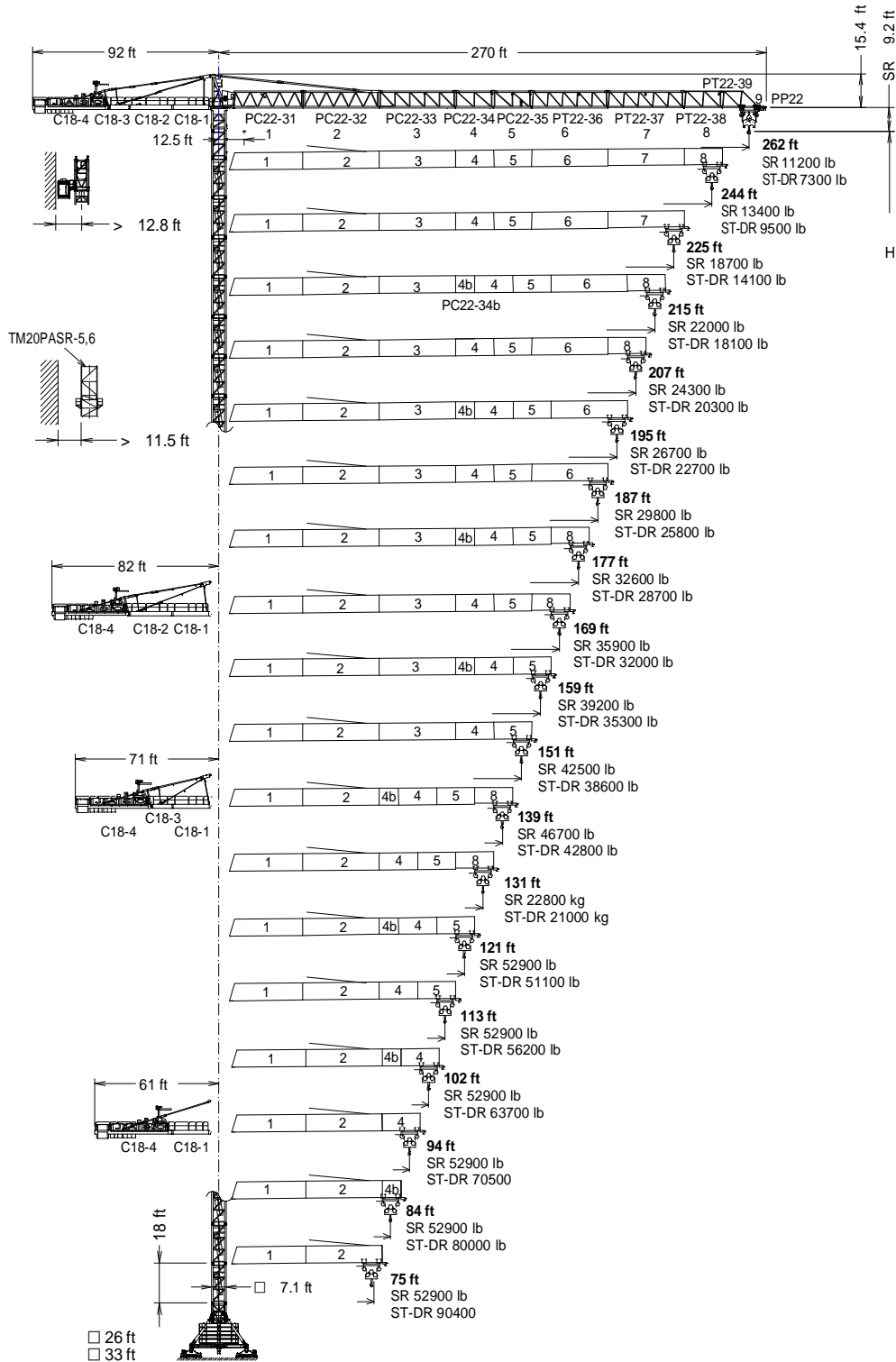

UNE 58-101
FEM 1001

UNE-EN-ISO 9001



C18-1	170.50.100	PC22-34	170.43.000	ASR20	160.21.200	BSR1 8-20-5,6	204.20.000
C18-2	170.50.200	PC22-34b	170.43.300	ASP20	212.21.200		ABH 100C
C18-3	170.50.300	PC22-35	170.44.000	TSR20	153.31.800	TM20PASR-5,6	206.35.000
C18-4	170.50.500	PT22-36	170.45.000	TSR20-5,6	204.31.000		
PC22-31	170.40.000	PT22-37	170.46.000	TSP20	212.32.400		
PC22-32	170.41.000	PT22-38	170.47.000	TSP20-5,6	212.31.000		
PC22-33	170.42.000	PT22-39	170.48.000	TSP20-5,6A	212.31.300		
		PP22	170.48.300				



Fecha / Date: 20/05/2020



Reservado el derecho a modificaciones sin previo aviso. Declinamos toda responsabilidad derivada de la información proporcionada / Subject to modification, without previous warning. This information is supplied without liability /

SR

(H_{SR}) ESTACIONARIA 1 / STATIONARY 1

▽▽	H(ft)	□	⊠
262	186	10	-
244	186	10	-
225	181	9	1
215	168	9	-
207	168	9	-
195	168	9	-
187	168	9	-
177	162	8	1
169	162	8	1
159	162	8	1
151	150	8	-
139	150	8	-
131	150	8	-
121	162	8	1
113	181	9	1
102	205	11	-
94	205	11	-
84	223	12	-
75	241	13	-

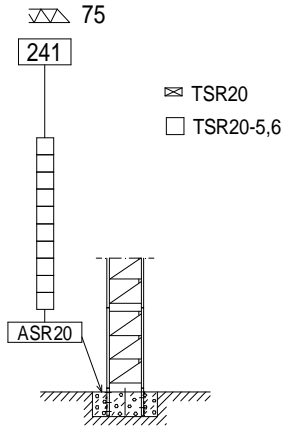

▽▽	H(ft)	⊠	≡	□	⊠
262	297	8	1	7	-
244	297	8	1	7	-
225	291	8	1	6	1
215	291	8	1	6	1
207	291	8	1	6	1
195	291	8	1	6	1
187	291	8	1	6	-
177	279	8	1	6	-
169	279	8	1	6	-
159	279	8	1	6	-
151	279	8	1	6	-
139	279	8	1	6	-
131	279	8	1	6	-
121	297	8	1	7	-
113	297	8	1	7	-
102	315	8	1	8	-
94	315	8	1	8	-
84	315	8	1	8	-
75	334	8	1	9	-

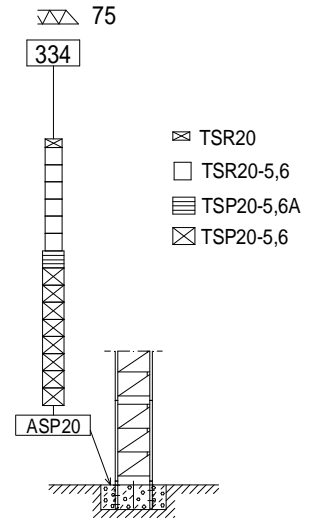

(H_{SR}) TRASLACIÓN / TRAVELLING

(H_{SR}) ESTACIONARIA 3 / STATIONARY 3

▽▽	H(ft)	□	⊠
262	205	9	1
244	205	9	1
225	193	9	-
215	174	8	-
207	174	8	-
195	174	8	-
187	174	8	-
177	174	8	-
169	174	8	-
159	174	8	-
151	156	7	-
139	156	7	-
131	156	7	-
121	169	7	1
113	187	8	1
102	211	10	-
94	211	10	-
84	242	11	1
75	260	12	1

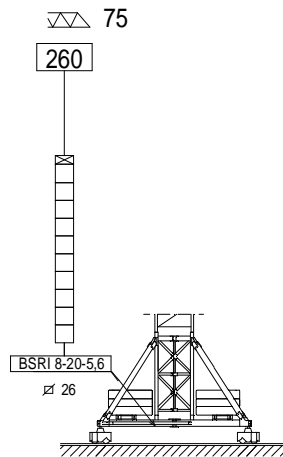

▽▽	H(ft)	□	⊠
262	203	9	1
244	203	9	1
225	190	9	-
215	185	8	1
207	185	8	1
195	185	8	1
187	185	8	1
177	172	8	-
169	172	8	-
159	172	8	-
151	166	7	1
139	166	7	1
131	166	7	1
121	172	8	-
113	190	9	-
102	221	10	1
94	221	10	1
84	240	11	1
75	258	12	1

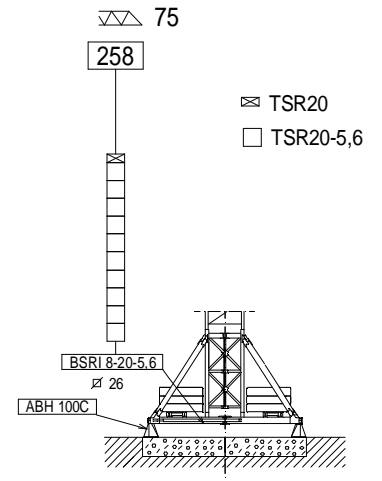

H = Altura máxima bajo gancho sin arristrar (m).
Maximum height under hook without fastening (m).



Fecha / Date: 20/05/2020

Reservado el derecho a modificaciones sin previo aviso. Declinamos toda responsabilidad derivada de la información proporcionada / Subject to modification, without previous warning. This information is supplied without liability /



ST-DR

(H_{SR}) ESTACIONARIA 1 / STATIONARY 1

▽▽	H(ft)	□	⊠
262	166	9	-
244	166	9	-
225	166	9	-
215	160	8	1
207	147	8	-
195	142	7	1
187	129	7	-
177	129	7	-
169	129	7	-
159	129	7	-
151	129	7	-
139	129	7	-
131	129	7	-
121	129	7	-
113	129	7	-
102	129	7	-
94	129	7	-
84	129	7	-
75	129	7	-

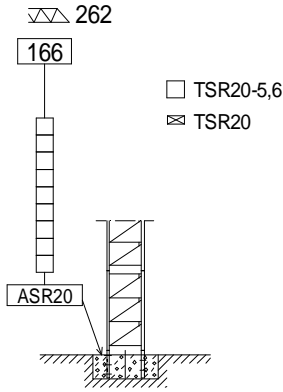

▽▽	H(ft)	⊠	≡	□	⊠
262	271	8	1	5	1
244	271	8	1	5	1
225	271	8	1	5	1
215	258	8	1	5	-
207	258	8	1	5	-
195	258	8	1	5	-
187	258	8	1	5	-
177	258	8	1	5	-
169	258	8	1	5	-
159	258	8	1	5	-
151	258	8	1	5	-
139	258	8	1	5	-
131	258	8	1	5	-
121	258	8	1	5	-
113	258	8	1	5	-
102	258	8	1	5	-
94	258	8	1	5	-
84	258	8	1	5	-
75	258	8	1	5	-

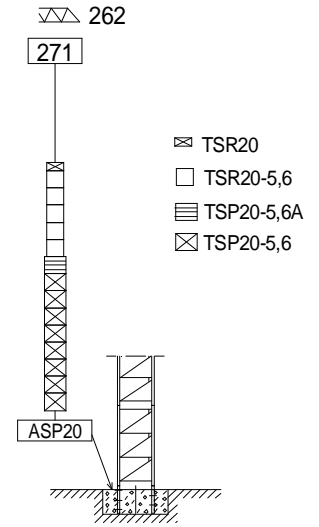

(H_{SR}) TRASLACIÓN / TRAVELLING

(H_{SR}) ESTACIONARIA 3 / STATIONARY 3

▽▽	H(m)	□	⊠
262	185	8	1
244	185	8	1
225	185	8	1
215	172	8	-
207	166	7	1
195	154	7	-
187	148	6	1
177	148	6	1
169	148	6	1
159	148	6	1
151	148	6	1
139	148	6	1
131	148	6	1
121	148	6	1
113	148	6	1
102	148	6	1
94	148	6	1
84	148	6	1
75	148	6	1

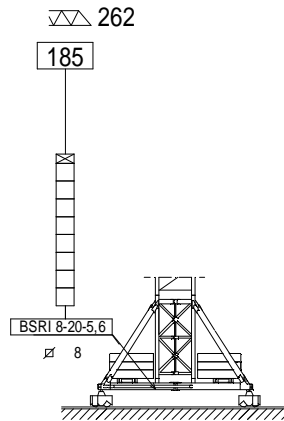

▽▽	H(m)	□	⊠
262	182	8	1
244	182	8	1
225	182	8	1
215	170	8	-
207	164	7	1
195	151	7	-
187	146	6	1
177	146	6	1
169	146	6	1
159	146	6	1
151	146	6	1
139	146	6	1
131	146	6	1
121	146	6	1
113	146	6	1
102	146	6	1
94	146	6	1
84	146	6	1
75	146	6	1

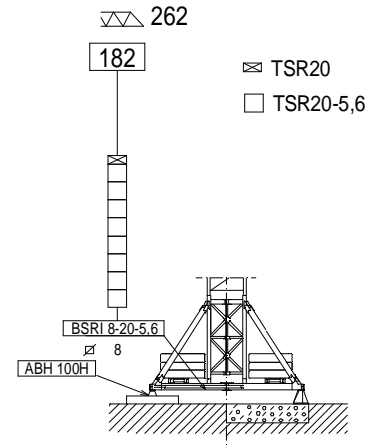

H = Altura máxima bajo gancho sin arriostrar (m).
Maximum height under hook without fastening (m)

H_{ST-SR} = H_{ST-DR} - 0.33 ft



Fecha / Date: 20/05/2020

FEM 1001

Reservado el derecho a modificaciones sin previo aviso. Declinamos toda responsabilidad derivada de la información proporcionada / Subject to modification, without previous warning. This information is supplied without liability /

Cargas máximas / Maximum loads
SR – 52900 lb

[ft]	52900 lb @ (ft)	Alcance del gancho [ft] / Hook reach [ft]																				
		49	66	75	84	94	102	113	121	131	139	151	159	169	177	187	195	207	215	225	244	262
262	74	52900	52900	52000	46500	41000	37300	33100	30400	27800	25800	23400	22000	20300	19200	17900	17000	15700	15000	14100	12600	11200
244	78	52900	52900	52900	49400	43700	39700	35100	32400	29500	27600	24900	23400	21800	20500	19200	18100	16800	16100	15000	13400	—
225	93	52900	52900	52900	52900	52500	47600	42300	39200	35700	33500	30400	28700	26700	25100	23600	22300	20700	19800	18700	—	—
215	101	52900	52900	52900	52900	52900	52500	46500	43000	39500	36800	33500	31500	29500	27800	26000	24700	23100	22000	—	—	—
207	105	52900	52900	52900	52900	52900	52900	48500	45000	41200	38600	35100	33100	30900	29100	27300	26000	24300	—	—	—	—
195	107	52900	52900	52900	52900	52900	52900	49800	46100	42300	39500	36000	34000	31500	30000	28000	26700	—	—	—	—	—
187	113	52900	52900	52900	52900	52900	52900	52700	48700	44500	41700	38100	36000	33500	31800	29800	—	—	—	—	—	—
177	115	52900	52900	52900	52900	52900	52900	52900	50000	45900	43000	39200	36800	34400	32600	—	—	—	—	—	—	—
169	120	52900	52900	52900	52900	52900	52900	52900	52000	47800	44800	40800	38600	36000	—	—	—	—	—	—	—	—
159	122	52900	52900	52900	52900	52900	52900	52900	52900	48700	45400	41700	39200	—	—	—	—	—	—	—	—	—
151	124	52900	52900	52900	52900	52900	52900	52900	52900	49800	46500	42600	—	—	—	—	—	—	—	—	—	—
139	125	52900	52900	52900	52900	52900	52900	52900	52900	50000	46700	—	—	—	—	—	—	—	—	—	—	—
131	125	52900	52900	52900	52900	52900	52900	52900	52900	50300	—	—	—	—	—	—	—	—	—	—	—	—
121	121	52900	52900	52900	52900	52900	52900	52900	52900	—	—	—	—	—	—	—	—	—	—	—	—	—
113	113	52900	52900	52900	52900	52900	52900	52900	—	—	—	—	—	—	—	—	—	—	—	—	—	—
102	102	52900	52900	52900	52900	52900	52900	—	—	—	—	—	—	—	—	—	—	—	—	—	—	—
94	94	52900	52900	52900	52900	52900	—	—	—	—	—	—	—	—	—	—	—	—	—	—	—	—
84	84	52900	52900	52900	52900	—	—	—	—	—	—	—	—	—	—	—	—	—	—	—	—	—
75	75	52900	52900	52900	—	—	—	—	—	—	—	—	—	—	—	—	—	—	—	—	—	—



Fecha / Date: 20/05/2020

FEM 1001

Reservado el derecho a modificaciones sin previo aviso. Declinamos toda responsabilidad derivada de la información proporcionada / Subject to modification, without previous warning. This information is supplied without liability /

 ST - SR [lb]		Cargas máximas / Maximum loads ST-SR – 52900 lb																				
		Alcance del gancho [ft] / Hook reach [ft]																				
52900 lb @ [ft]	[ft]	49	66	75	84	94	102	113	121	131	139	151	159	169	177	187	195	207	215	225	244	262
262	73	52900	52900	51100	45400	39900	35900	31500	28900	26000	24000	21600	20100	18500	17200	15900	15000	13700	12800	11900	10400	9000
244	77	52900	52900	52900	48300	42300	38100	33500	30600	27800	25800	23100	21600	19800	18500	17200	16100	14800	13900	13000	11200	—
225	91	52900	52900	52900	52900	50900	46300	40800	37500	34000	31500	28400	26700	24700	23100	21400	20300	18700	17600	16500	—	—
215	98	52900	52900	52900	52900	52900	51000	44800	41200	37500	34800	31700	29500	27300	25800	24000	22700	20900	19800	—	—	—
207	102	52900	52900	52900	52900	52900	52900	47000	43200	39200	36600	33100	31100	28700	27100	25100	23800	22000	—	—	—	—
195	104	52900	52900	52900	52900	52900	52900	48100	44300	40300	37500	34000	31700	29500	27800	25800	24500	—	—	—	—	—
187	109	52900	52900	52900	52900	52900	52900	50700	46700	42800	39700	36200	33700	31300	29500	27600	—	—	—	—	—	—
177	112	52900	52900	52900	52900	52900	52900	52000	48100	43900	40800	37000	34800	31300	30400	—	—	—	—	—	—	—
169	116	52900	52900	52900	52900	52900	52900	52900	50000	45600	42500	38800	36400	32200	—	—	—	—	—	—	—	—
159	118	52900	52900	52900	52900	52900	52900	52900	51000	46500	43400	39500	37000	—	—	—	—	—	—	—	—	—
151	120	52900	52900	52900	52900	52900	52900	52900	52000	47600	44300	40300	—	—	—	—	—	—	—	—	—	—
139	120	52900	52900	52900	52900	52900	52900	52900	52300	47800	44500	—	—	—	—	—	—	—	—	—	—	—
131	121	52900	52900	52900	52900	52900	52900	52900	52700	48100	—	—	—	—	—	—	—	—	—	—	—	—
121	121	52900	52900	52900	52900	52900	52900	52900	52900	—	—	—	—	—	—	—	—	—	—	—	—	—
113	113	52900	52900	52900	52900	52900	52900	52900	—	—	—	—	—	—	—	—	—	—	—	—	—	—
102	102	52900	52900	52900	52900	52900	52900	—	—	—	—	—	—	—	—	—	—	—	—	—	—	—
94	94	52900	52900	52900	52900	52900	—	—	—	—	—	—	—	—	—	—	—	—	—	—	—	—
84	84	52900	52900	52900	52900	—	—	—	—	—	—	—	—	—	—	—	—	—	—	—	—	—
75	75	52900	52900	52900	—	—	—	—	—	—	—	—	—	—	—	—	—	—	—	—	—	—

 ST - DR [lb]		Cargas máximas / Maximum loads ST-DR – 105800 lb																					
		Alcance del gancho [ft] / Hook reach [ft]																					
105800 lb @ [ft]	[ft]	33	49	66	75	84	94	102	113	121	131	139	151	159	169	177	187	195	207	215	225	244	262
262	38	105800	79600	57300	48500	43000	37500	33700	29300	26700	24000	22000	19600	18100	16500	15200	14100	13000	11700	11000	10100	8600	7300
244	40	105800	84400	60800	51800	45600	39900	36000	31300	28700	25800	23600	21200	19600	17900	16800	15200	14300	13000	12100	11200	9500	—
225	47	105800	101000	73400	62600	55600	48700	44100	38600	35300	32000	29500	26700	24700	22700	21200	19600	18500	17000	15900	14800	—	—
215	51	105800	105800	80400	68800	61300	53800	48700	42800	39200	35500	32800	29800	27800	25600	24000	22300	21000	19200	18100	—	—	—
207	53	105800	105800	84000	71900	64000	56200	50900	44800	41200	37300	34600	31300	29100	26900	25100	23400	22000	20300	—	—	—	—
195	54	105800	105800	86200	73600	65500	57500	52200	46100	42300	38400	35500	32200	30000	27800	26000	24000	22700	—	—	—	—	—
187	57	105800	105800	90800	77800	69200	61100	55300	48700	44800	40800	37700	34200	32000	29500	27800	25800	—	—	—	—	—	—
177	58	105800	105800	93300	80000	71200	62600	56900	50300	46100	41900	39000	35300	33100	30400	28700	—	—	—	—	—	—	—
169	61	105800	105800	97000	83100	74100	65300	59300	52300	48300	43900	40800	36800	34600	32000	—	—	—	—	—	—	—	—
159	62	105800	105800	100000	84900	75600	66600	60400	53400	49200	44800	41700	37700	35300	—	—	—	—	—	—	—	—	—
151	63	105800	105800	101000	86600	77200	68100	61700	54700	50300	45900	42500	38600	—	—	—	—	—	—	—	—	—	—
139	63	105800	105800	101400	87100	77600	68300	62200	54900	50500	46100	42800	—	—	—	—	—	—	—	—	—	—	—
131	63	105800	105800	102100	87500	78000	68800	62400	55100	50900	46300	—	—	—	—	—	—	—	—	—	—	—	—
121	64	105800	105800	102500	88000	78500	69200	62800	55600	51100	—	—	—	—	—	—	—	—	—	—	—	—	—
113	64	105800	105800	103900	89100	79400	70100	63700	56200	—	—	—	—	—	—	—	—	—	—	—	—	—	—
102	65	105800	105800	103900	89100	79600	70300	63700	—	—	—	—	—	—	—	—	—	—	—	—	—	—	—
94	65	105800	105800	104500	89700	80000	70500	—	—	—	—	—	—	—	—	—	—	—	—	—	—	—	—
84	65	105800	105800	104700	89700	80000	—	—	—	—	—	—	—	—	—	—	—	—	—	—	—	—	—
75	65	105800	105800	105400	90400	—	—	—	—	—	—	—	—	—	—	—	—	—	—	—	—	—	—



Fecha / Date: 20/05/2020



Reservado el derecho a modificaciones sin previo aviso. Declinamos toda responsabilidad derivada de la información proporcionada / Subject to modification, without previous warning. This information is supplied without liability /

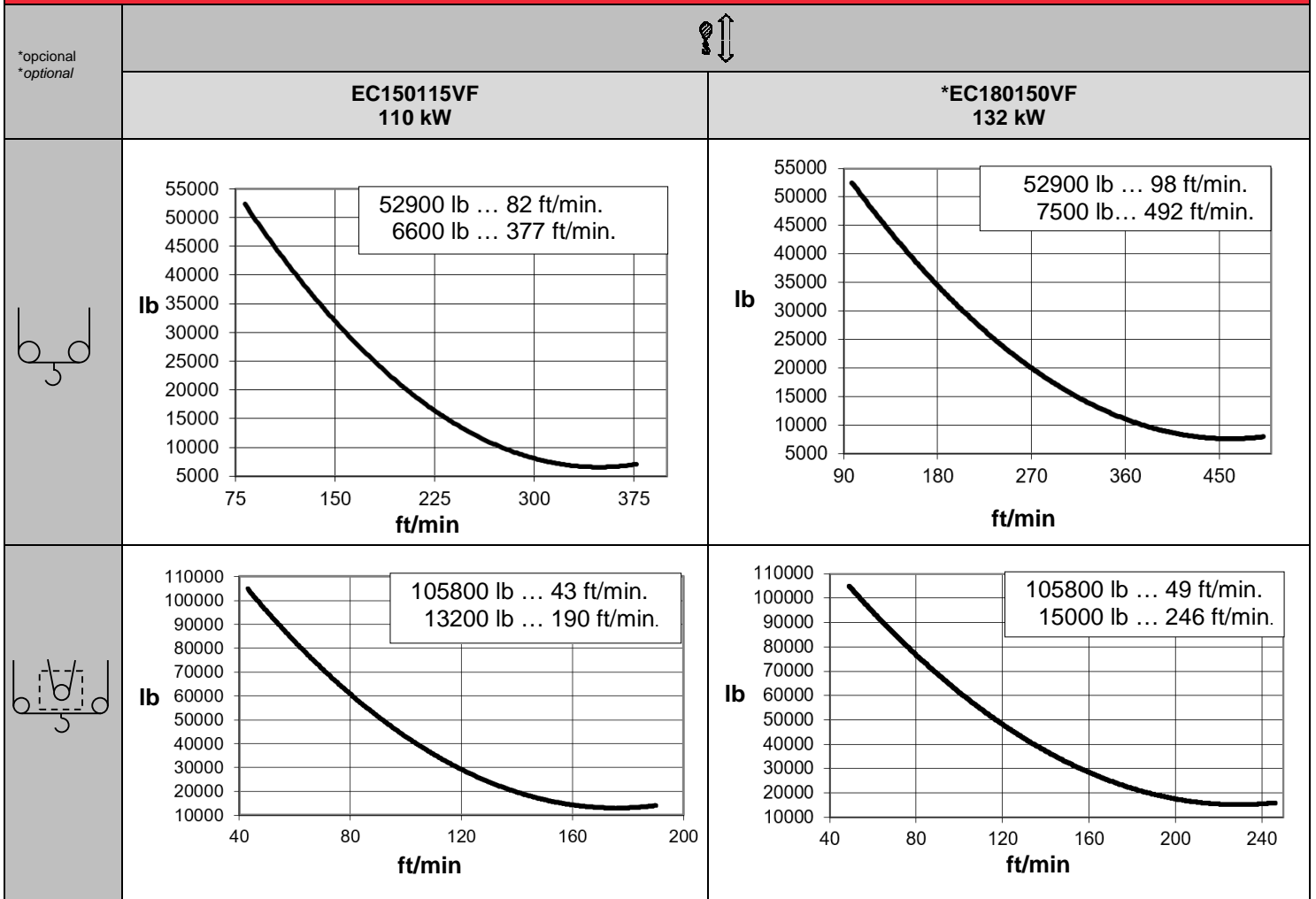

			480V 60Hz	
OG4006VF 4 x 7,5 kW	TC2560VF 18,4 kW	TH4010 29,4 kW	EC150115VF: AMPERAGE = 246 A EC180150VF AMPERAGE = 279 A	
0...0,7 r/min sl/min	<u>52900 lb</u> 0...197 ft/min <u>105800 lb</u> 0...98 ft/min	2 ft/min	 $H \leq \begin{matrix} SR \\ DR \end{matrix} \begin{matrix} 1493 \text{ ft} \\ 745 \text{ ft} \end{matrix}$ 3635 ft	



Fecha / Date: 20/05/2020

FEM 1001

Reservado el derecho a modificaciones sin previo aviso. Declinamos toda responsabilidad derivada de la información proporcionada / Subject to modification, without previous warning. This information is supplied without liability /

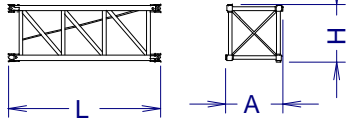
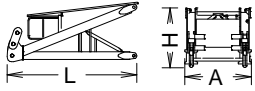
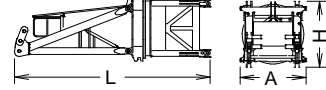
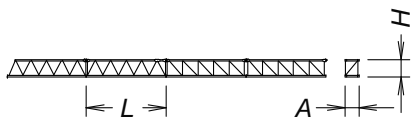
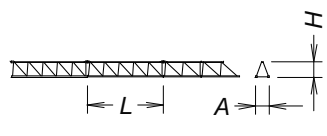
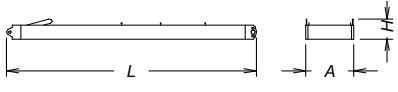
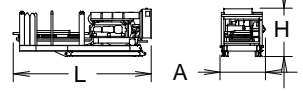
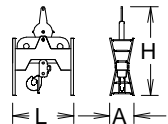
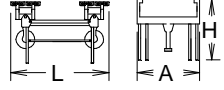
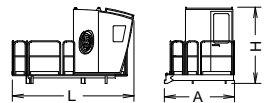
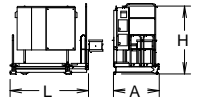
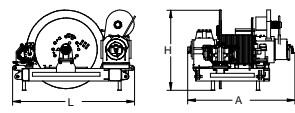
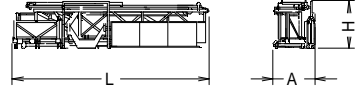
DENOMINACIÓN / DENOMINATION		L [ft]	A [ft]	H [ft]	P / W [lb]	
Torre Tower	TSR20	14.0	7.4	7.4	6860	
	TSR20-5,6	19.7	7.4	7.4	9425	
	TSR120-5,6	19.7	7.4	7.4	15100	
	TSP20	14.4	7.8	7.9	12380	
	TSP20-5,6	20.2	7.8	7.9	16900	
	TSP20-5,6A	19.9	7.5	7.8	15710	
Torre asiento pista + base punta de torre + orientación Slewing table + tower head base + slewing mechanism			15.0	7.7	8.5	28150
Punta de torre Tower head			14.3	7.3	7.7	8620
Conjunto asiento pista. punta de torre y orientación Slewing table assembly. tower head and slewing mechanism			26.6	10.8	9.5	36770
Tramo de pluma Jib section	PC22-31		38.5	7.6	8.2	14630
	PC22-32 + Tr		38.6	6.8	8.2	18300
	PC22-33		38.7	6.8	8.1	13870
	PC22-34b		10.5	6.8	8.1	3890
	PC22-34		19.9	6.8	8.1	6500
	PC22-35		19.8	6.8	8.1	5950
	PT22-36		38.5	6.8	8.1	6670
	PT22-37		38.5	6.8	8.1	4960
	PT22-38		19.4	6.8	8.0	2650
	PT22-39		19.2	6.8	8.0	1700
PP22	4.1	7.6	2.1	1260		
Contrapluma Counterjib	C18-1		20.3	6.8	2.5	6180
	C18-2		21.8	6.6	2.9	6660
	C18-3		10.8	6.6	2.9	3980
	C18-4		37.9	6.9	3.3	12810
Contrapluma + Mec. Elevación +Armario eléctrico Counterjib + Hoisting Mech.+ Electrical cabinet			37.9	7.5	7.6	33390
Polipasto Hook assembly	SR		5.7	5.3	1.2	2315
	ST/DR		7.0	2.9	10.3	4740
Carro Trolley	SR		9.3	7.6	9.0	3010
	ST/DR		11.0	7.8	9.5	4660
Plataforma y cabina Platform and cabin			12.7	7.3	8.2	2560
Armario eléctrico y plataforma Electrical cabinet and platform			9.0	5.3	8.1	2230
Soporte y elevación (sin cable) Support and hoisting (without rope)			8.3	7.3	5.5	12790
Transporte torre de montaje/ Jacking cage transport TM20PASR-5,6			35.5	7.5	7.9	26760



Fecha / Date: 20/05/2020



Reservado el derecho a modificaciones sin previo aviso. Declinamos toda responsabilidad derivada de la información proporcionada / Subject to modification, without previous warning. This information is supplied without liability /

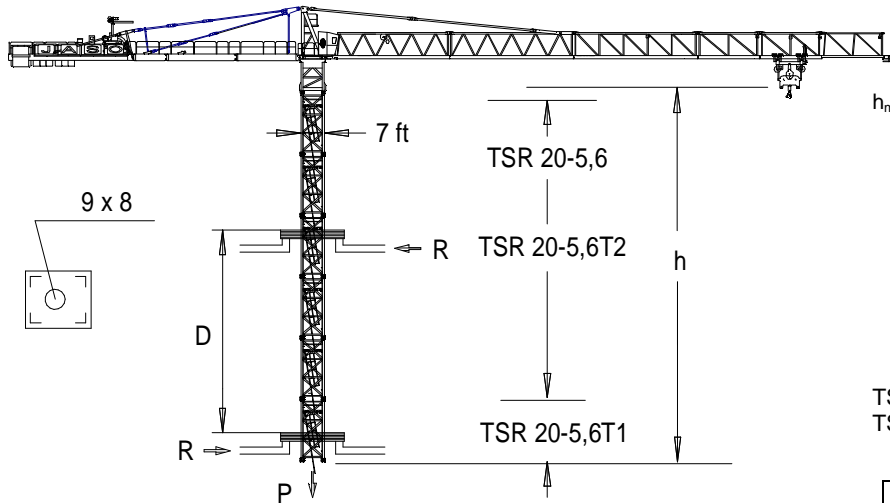

$h_{max}: \text{TSR20-5,6T1} + 5 \times \text{TSR20-5,6} + \text{TSR20-5,6T2}$

	▶	■
169 ft ST-DR (105800 lb)		
h (ft)	128	
D (ft)	49.2 – 58.7	
P (lbf)	491200	383300
Rmax (lbf)	94400	139400

TSR20-5,6T1: 204.31.600

TSR20-5,6T2: 204.31.900

	Trepado interno / Internal climbing.
---	--------------------------------------



Ctra./Rd. Madrid - Irún Km. 415 - 20.213 IDIAZABAL [Gipuzkoa] ESPAÑA / SPAIN
 P.O. Box, 23 - 20.200 BEASAIN - E-mail: jaso@jaso.com
 Tel. +34 943 - 18 70 00 • Fax. +34 943 - 18 70 20
www.jaso.com

Fecha / Date: 20/05/2020

Reservado el derecho a modificaciones sin previo aviso. Declinamos toda responsabilidad derivada de la información proporcionada / Subject to modification, without previous warning. This information is supplied without liability

 **FEM 1001**

DELEGACION / DEALER