

INTERSTATE

THE
PERFECT
CONNECTION



FEATURES

- CONTINUOUS MAIN BEAM DESIGN
- HEAVY DUTY SPRING SUSPENSION
- SEALED BEAM ELECTRICAL SYSTEM
- BREAKAWAY SYSTEM
- REAR RAMPS FOR ROLLER
- 16,000 Lb. Capacity
- SIDE RAMPS FOR PAVER
- DISC WHEELS – 8 BOLT

16PBS

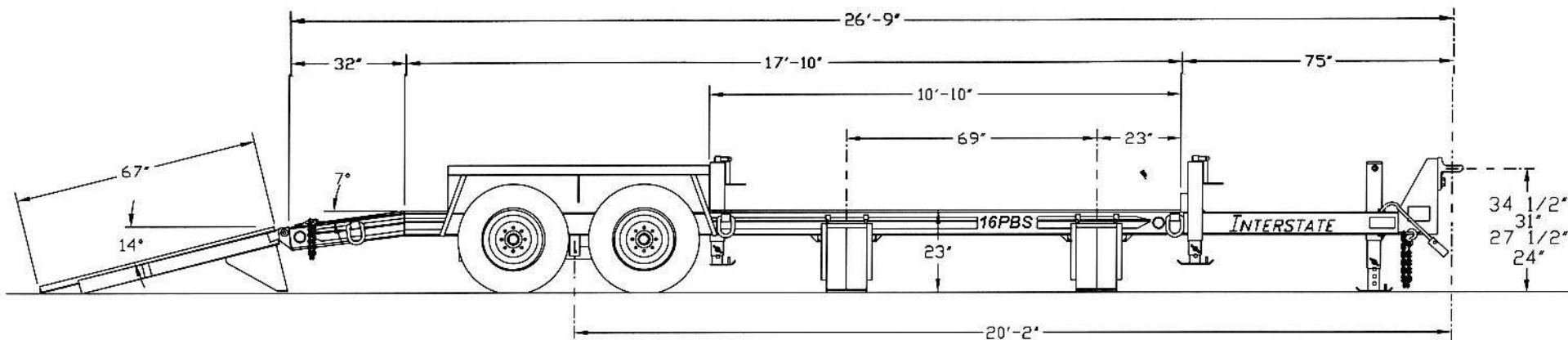

MODEL: 16PBS

CAPACITY:	16,000 lbs.	Ramp Width (Side):	13 ⁷ / ₈ "
Trailer Weight:	4,800#	Decking:	2" Nominal Hardwood
Overall Length:	26' 9"	Main Rails:	W6" 16# A572 Gr. 50 Hi-Tensile
Overall Width:	102"	Crossmembers:	4" x 3.2# I Beam Gr. 50 Hi-Tensile
Platform Length:	20' 6"	Heavy Duty Axles:	(2) 8,000# - 4" Drop
Platform Width:	102"	Heavy Duty Brakes:	Electric - 12 ¹ / ₄ " x 3 ³ / ₈ "
Width Between Fenders:	80"	Heavy Duty Suspension:	Spring Type
Platform Height:	23"	Tires:	(4) 215/75R x 17.5 - 16PR Radial
Dovetail Length:	32"	Heavy Duty Wheels:	(4) 6.75 x 17.5 8 Bolt Disc
Ramp Length (Rear):	67"	Lights & Electric:	Sealed Beam System/ICC & DOT Approved
Ramp Width (Rear):	21 ¹ / ₂ "	Hitch:	Adjustable Pintle Eye - 4 Position
Ramp Length (Side):	77 ¹ / ₂ "		

Gel Cell Break-A-Way Switch System with Battery
 Heavy Duty Jack: 12,000 # Screw Type

Interstate Trailers, Inc. reserves the right to change design, material and/or specifications without notice and without incurring any obligation to such changes.

Your **INTERSTATE** Dealer Is