

# **INTERSTATE**

**THE  
PERFECT  
CONNECTION**



## **FEATURES**

- ELECTRIC BRAKES ON ALL WHEELS
- DOVETAIL & RAMPS FOR EASY LOADING
- SEALED BEAM ELECTRICAL SYSTEM
- OPTIONAL BUDD TYPE WHEELS WITH 235/85Rx16 TIRES
- LOW DECK HEIGHT

# **10ST**

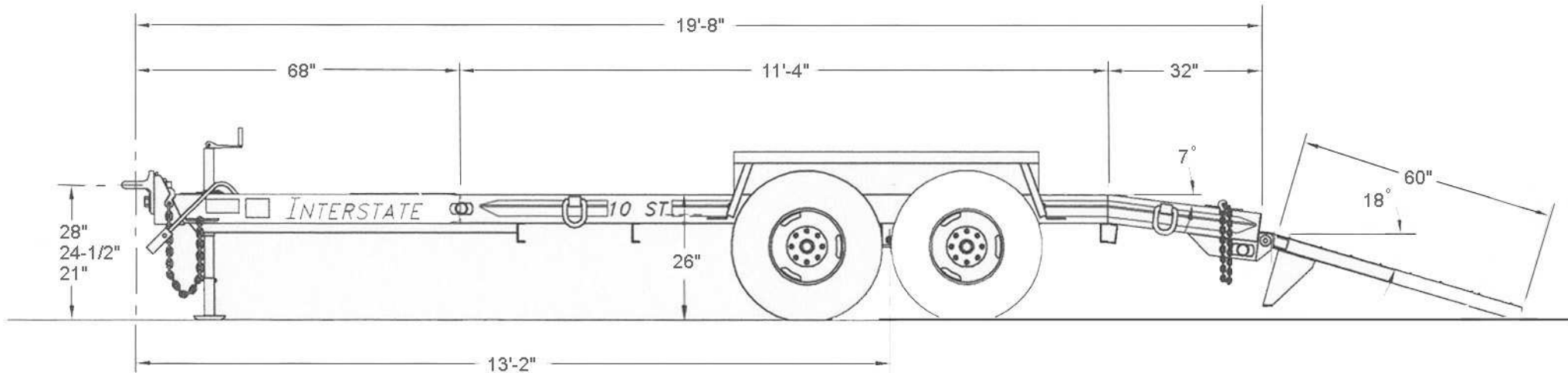

## MODEL 10ST

CAPACITY:	10,000# @ 55 MPH	Hitch:	Adjustable Pintle Eye
Trailer Weight:	2730#	Heavy Duty Axles:	(2) 6,000#
Overall Length:	19' - 8"	Heavy Duty Brakes:	Electric 12" x 2" - Each Wheel
Overall Width:	<b>102"</b>	Heavy Duty Suspension:	Spring Type
Platform Length:	14' - 0"	Tires:	235/85R x 16 - 10 Ply Radial
Platform Width:	<b>81" Between Fenders</b>	Wheels:	<b>8 hole steel disc</b>
Platform Height:	<b>26" Unloaded</b>	Jack:	10,000 lb. Drp Leg
Frame:	<b>One Piece, Continuous</b>	Lights & Electric:	<b>DOT Approved LED Lights, Sealed, Modular Wiring Harness</b>
Main Beams:	6" Channel x 10.5 Lbs. / ft.	Ramps:	Length: 60" Width: 21"
Crossmembers:	4" Channel x 5.4 Lbs. / ft.		
Decking:	2" Nominal Hardwood		

Gell Cell Break-A-Way Switch System with Battery

Your **INTERSTATE** Dealer Is